

FAIRCHILD
SEMICONDUCTOR™

September 1983
Revised February 1999

MM74HC139 Dual 2-To-4 Line Decoder

MM74HC139 Dual 2-To-4 Line Decoder

General Description

The MM74HC139 decoder utilizes advanced silicon-gate CMOS technology, and is well suited to memory address decoding or data routing applications. It possesses the high noise immunity and low power consumption usually associated with CMOS circuitry, yet has speeds comparable to low power Schottky TTL logic.

The MM74HC139 contain two independent one-of-four decoders each with a single active low enable input (G1, or G2). Data on the select inputs (A1, and B1 or A2, and B2) cause one of the four normally high outputs to go LOW.

The decoder's outputs can drive 10 low power Schottky TTL equivalent loads, and are functionally as well as pin

equivalent to the 74LS139. All inputs are protected from damage due to static discharge by diodes to V_{CC} and ground.

Features

- Typical propagation delays —
 - Select to outputs (4 delays): 18 ns
 - Select to output (5 delays): 28 ns
 - Enable to output: 20 ns
- Low power: 40 μ W quiescent supply power
- Fanout of 10 LS-TTL devices
- Input current maximum 1 μ A, typical 10 pA

Ordering Code:

Order Number	Package Number	Package Description
MM74HC139M	M16A	16-Lead Small Outline Integrated Circuit (SOIC), JEDEC MS-012, 0.150" Narrow
MM74HC139SJ	M16D	16-Lead Small Outline Package (SOP), EIAJ TYPE II, 5.3mm Wide
MM74HC139MTC	MTC16	16-Lead Thin Shrink Small Outline Package (TSSOP) JEDEC MO-153, 4.4mm Wide
MM74HC139N	N16E	16-Lead Plastic Dual-In-Line Package (PDIP), JEDEC MS-001, 0.300" Wide

Devices also available in Tape and Reel. Specify by appending the suffix letter "X" to the ordering code.

Connection Diagram

Pin Assignments for DIP, SOIC, SOP and TSSOP

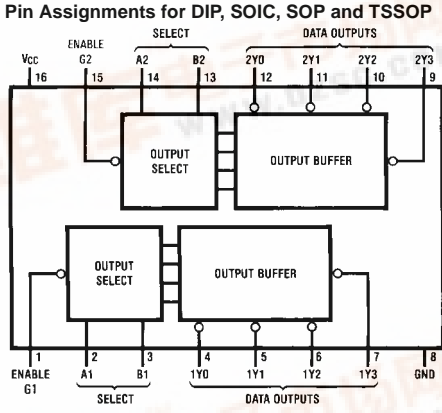

Truth Table

Inputs			Outputs			
Enable	Select		Y0	Y1	Y2	Y3
G	B	A				
H	X	X	H	H	H	H
L	L	L	L	H	H	H
L	L	H	H	L	H	H
L	H	L	H	H	L	H
L	H	H	H	H	H	L

H = HIGH Level
L = LOW Level
X = Don't Care



MM74HC139

Logic Diagram

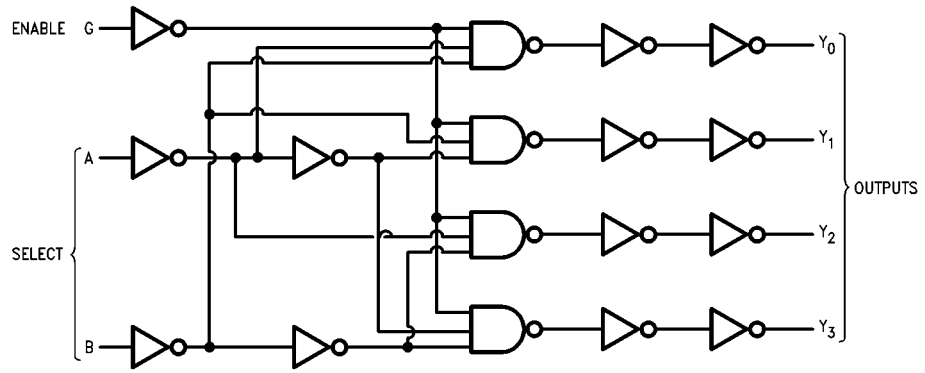

(1 of 2)

Absolute Maximum Ratings ^(Note 1)				Recommended Operating Conditions				
(Note 2)								
Supply Voltage (V_{CC})		-0.5 to +7.0V		Min	Max	Units		
DC Input Voltage (V_{IN})		-1.5 to $V_{CC} + 1.5V$	Supply Voltage (V_{CC})	2	6	V		
DC Output Voltage (V_{OUT})		-0.5 to $V_{CC} + 0.5V$	DC Input or Output Voltage	0	V_{CC}	V		
Clamp Diode Current (I_{IK}, I_{OK})		± 20 mA	(V_{IN}, V_{OUT})					
DC Output Current, per pin (I_{OUT})		± 25 mA	Operating Temperature Range (T_A)	-40	+85	$^{\circ}C$		
DC V_{CC} or GND Current, per pin (I_{CC})		± 50 mA	Input Rise or Fall Times					
Storage Temperature Range (T_{STG})		-65 $^{\circ}C$ to +150 $^{\circ}C$	(t_r, t_f) $V_{CC} = 2.0V$			1000	ns	
Power Dissipation (P_D)			$V_{CC} = 4.5V$			500	ns	
(Note 3)		600 mW	$V_{CC} = 6.0V$			400	ns	
S.O. Package only		500 mW						
Lead Temperature (T_L)								
(Soldering 10 seconds)		260 $^{\circ}C$						
<p>Note 1: Absolute Maximum Ratings are those values beyond which damage to the device may occur.</p> <p>Note 2: Unless otherwise specified all voltages are referenced to ground.</p> <p>Note 3: Power Dissipation temperature derating — plastic "N" package: -12 mW/$^{\circ}C$ from 65$^{\circ}C$ to 85$^{\circ}C$.</p>								
DC Electrical Characteristics (Note 4)								
Symbol	Parameter	Conditions	V_{CC}	$T_A = 25^{\circ}C$		$T_A = -40$ to $85^{\circ}C$	$T_A = -55$ to $125^{\circ}C$	Units
				Typ	Guaranteed Limits			
V_{IH}	Minimum HIGH Level Input Voltage		2.0V		1.5	1.5	1.5	V
			4.5V		3.15	3.15	3.15	V
			6.0V		4.2	4.2	4.2	V
V_{IL}	Maximum LOW Level Input Voltage		2.0V		0.5	0.5	0.5	V
			4.5V		1.35	1.35	1.35	V
			6.0V		1.8	1.8	1.8	V
V_{OH}	Minimum HIGH Level Output Voltage	$V_{IN} = V_{IH}$ or V_{IL} $ I_{OUT} \leq 20 \mu A$	2.0V	2.0	1.9	1.9	1.9	V
			4.5V	4.5	4.4	4.4	4.4	V
			6.0V	6.0	5.9	5.9	5.9	V
		$V_{IN} = V_{IH}$ or V_{IL} $ I_{OUT} \leq 4.0$ mA $ I_{OUT} \leq 5.2$ mA	4.5V	4.2	3.98	3.84	3.7	V
			6.0V	5.7	5.48	5.34	5.2	V
V_{OL}	Maximum LOW Level Output Voltage	$V_{IN} = V_{IH}$ or V_{IL} $ I_{OUT} \leq 20 \mu A$	2.0V	0	0.1	0.1	0.1	V
			4.5V	0	0.1	0.1	0.1	V
			6.0V	0	0.1	0.1	0.1	V
		$V_{IN} = V_{IH}$ or V_{IL} $ I_{OUT} \leq 4.0$ mA $ I_{OUT} \leq 5.2$ mA	4.5V	0.2	0.26	0.33	0.4	V
			6.0V	0.2	0.26	0.33	0.4	V
I_{IN}	Maximum Input Current	$V_{IN} = V_{CC}$ or GND	6.0V		± 0.1	± 1.0	± 1.0	μA
I_{CC}	Maximum Quiescent Supply Current	$V_{IN} = V_{CC}$ or GND $I_{OUT} = 0 \mu A$	6.0V		8.0	80	160	μA
<p>Note 4: For a power supply of 5V $\pm 10\%$ the worst case output voltages (V_{OH} and V_{OL}) occur for HC at 4.5V. Thus the 4.5V values should be used when designing with this supply. Worst case V_{IH} and V_{IL} occur at $V_{CC} = 5.5V$ and 4.5V respectively. (The V_{IH} value at 5.5V is 3.85V.) The worst case leakage current (I_{IN}, I_{CC}, and I_{OZ}) occur for CMOS at the higher voltage and so the 6.0V values should be used.</p>								

AC Electrical Characteristics					
$V_{CC} = 5V, T_A = 25^\circ C, C_L = 15 \text{ pF}, t_r = t_f = 6 \text{ ns}$					
Symbol	Parameter	Conditions	Typ	Guaranteed Limit	Units
t_{PHL}, t_{PLH}	Maximum Propagation Delay, Binary Select to any Output 4 levels of delay		18	30	ns
t_{PHL}, t_{PLH}	Maximum Propagation Delay, Binary Select to any Output 5 levels of delay		28	38	ns
t_{PHL}, t_{PLH}	Maximum Propagation Delay, Enable to any Output		19	30	ns

AC Electrical Characteristics								
$C_L = 50 \text{ pF}, t_r = t_f = 6 \text{ ns}$ (unless otherwise specified)								
Symbol	Parameter	Conditions	V_{CC}	$T_A = 25^\circ C$	$T_A = -40 \text{ to } 85^\circ C$	$T_A = -55 \text{ to } 125^\circ C$	Units	
				Typ	Guaranteed Limits			
t_{PHL}, t_{PLH}	Maximum Propagation Delay Binary Select to any Output 4 levels of delay	(Note 5)	2.0V	110	175	219	254	ns
			4.5V	22	35	44	51	ns
			6.0V	18	30	38	44	ns
t_{PHL}, t_{PLH}	Maximum Propagation Delay Binary Select to any Output 5 levels of delay	(Note 6)	2.0V	165	220	275	320	ns
			4.5V	33	44	55	64	ns
			6.0V	28	38	47	54	ns
t_{PHL}, t_{PLH}	Maximum Propagation Delay Enable to any Output		2.0V	115	175	219	254	ns
			4.5V	23	35	44	51	ns
			6.0V	19	30	38	44	ns
t_{TLH}, t_{TLH}	Maximum Output Rise and Fall Time		2.0V	30	75	95	110	ns
			4.5V	8	15	19	22	ns
			6.0V	7	13	16	19	ns
C_{IN}	Maximum Input Capacitance			3	10	10	10	pF
C_{PD}	Power Dissipation Capacitance (Note 7)	(Note 7)		75				pF

Note 5: 4 levels of delay are A to Y1, Y3 and B to Y2, Y3.

Note 6: 5 levels of delay are A to Y0, Y2 and B to Y0, Y1.

Note 7: C_{PD} determines the no load dynamic power consumption, $P_D = C_{PD} V_{CC}^2 f + I_{CC} V_{CC}$, and the no load dynamic current consumption, $I_S = C_{PD} V_{CC} f + I_{CC}$.

Physical Dimensions inches (millimeters) unless otherwise noted

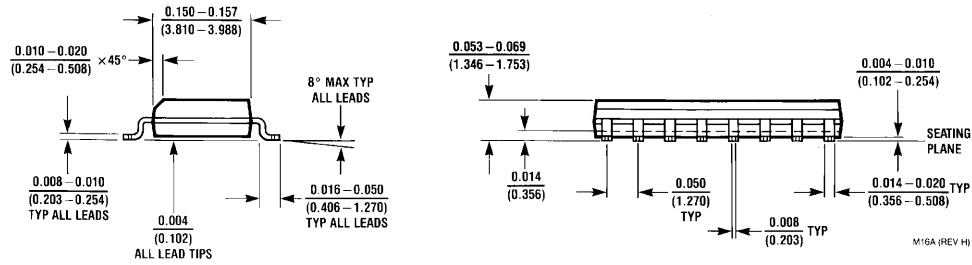
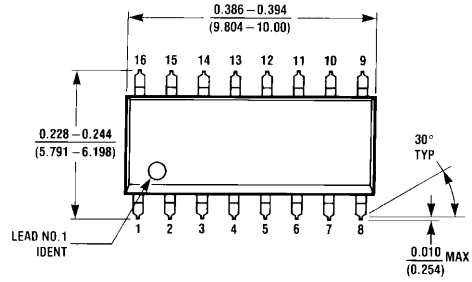

16-Lead Small Outline Integrated Circuit (SOIC), JEDEC MS-012, 0.150" Narrow Package Number M16A

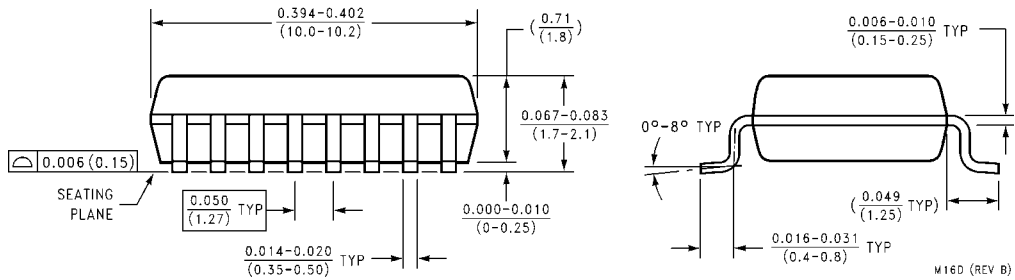
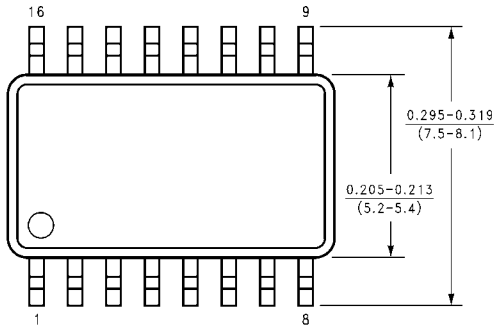

16-Lead Small Outline Package (SOP) EIAJ TYPE II, 5.3mm Wide Package Number M16D

Physical Dimensions inches (millimeters) unless otherwise noted (Continued)

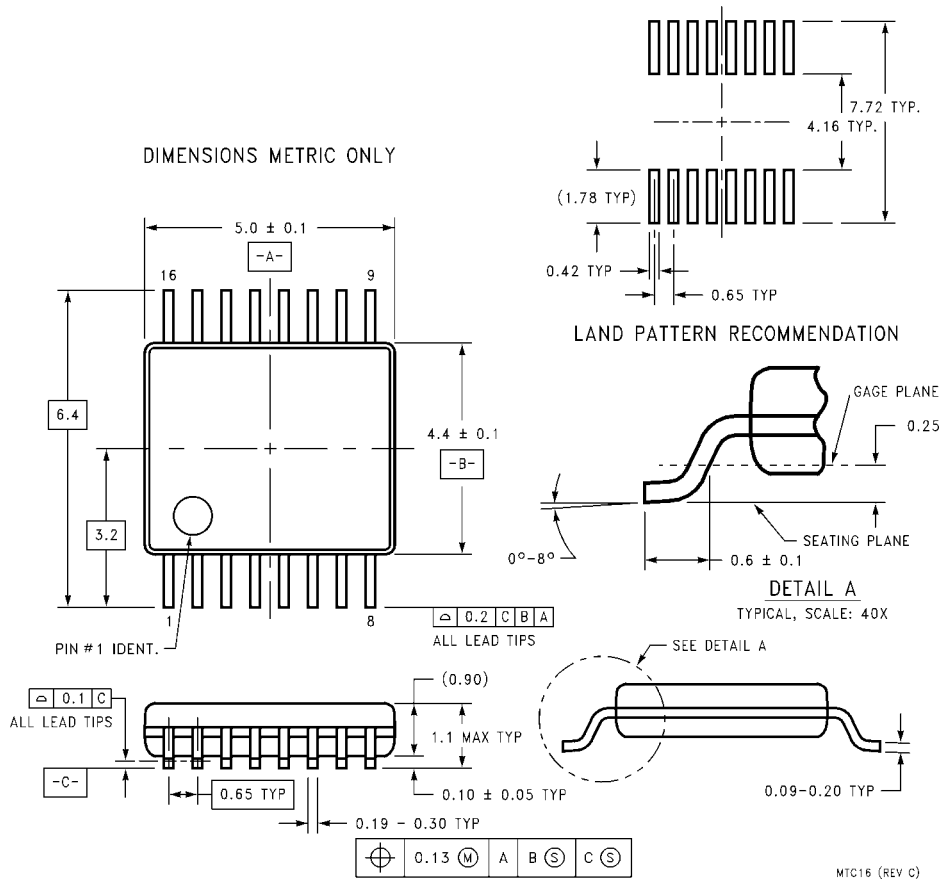

**16-Lead Thin Shrink Small Outline Package (TSSOP), JEDEC MO-153, 4.4mm Wide
Package Number MTC16**

Physical Dimensions inches (millimeters) unless otherwise noted (Continued)

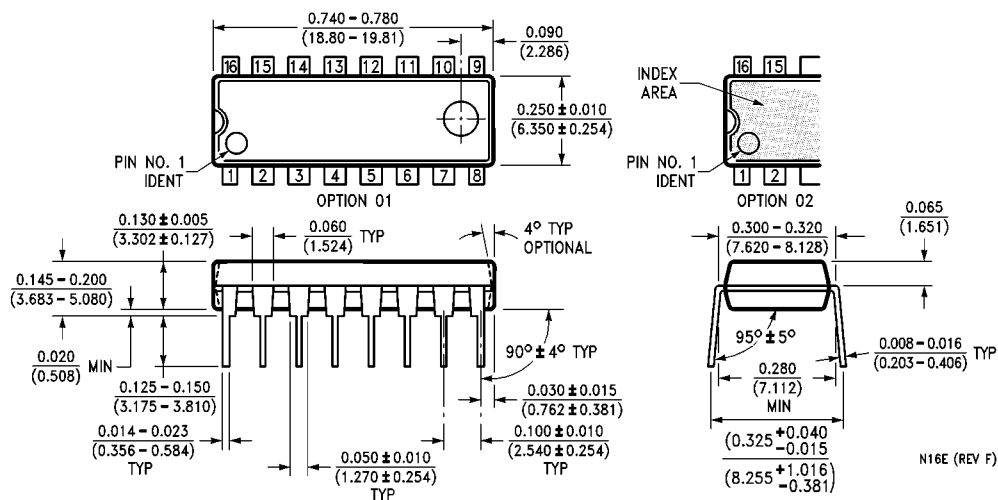

**16-Lead Plastic Dual-In-Line Package (PDIP), JEDEC MS-001, 0.300" Wide
Package Number N16E**

LIFE SUPPORT POLICY

FAIRCHILD'S PRODUCTS ARE NOT AUTHORIZED FOR USE AS CRITICAL COMPONENTS IN LIFE SUPPORT DEVICES OR SYSTEMS WITHOUT THE EXPRESS WRITTEN APPROVAL OF THE PRESIDENT OF FAIRCHILD SEMICONDUCTOR CORPORATION. As used herein:

1. Life support devices or systems are devices or systems which, (a) are intended for surgical implant into the body, or (b) support or sustain life, and (c) whose failure to perform when properly used in accordance with instructions for use provided in the labeling, can be reasonably expected to result in a significant injury to the user.
2. A critical component in any component of a life support device or system whose failure to perform can be reasonably expected to cause the failure of the life support device or system, or to affect its safety or effectiveness.

www.fairchildsemi.com