

□ MN101C425 / 427

Type		MN101C425 (under planning) / 427	
ROM (×8-Bit)		8 K / 16 K	
RAM (×8-Bit)		256 / 512	
Minimum Instruction Execution Time		0.10 μs (at 4.5 V to 5.5 V, 20 MHz) 0.25 μs (at 2.7 V to 5.5 V, 8 MHz) 0.5 μs (at 2.0 V to 5.5 V, 4 MHz)* 125 μs (at 2.0 V to 5.5 V, 32 kHz)* * The lower limit for operation guarantee for EPROM built-in version is 2.7 V.	
Interrupts		• RESET • Watchdog • External 0 • External 1 • External 2 • External 3 (Only 48-pin package) • Timer 2 • Timer 3 • Timer 4 • Timer 5 • Time Base • Serial 0 • A/D Conversion finish	
Timer Counter		<p>Timer Counter 2 : 8-Bit × 1 (Square-Wave/8-Bit PWM Output, Event Count, Synchronous Output Event)</p> Clock Source . . . 1/1, 1/4 of System Clock, 1/1 of XI Oscillation Clock (Only 48-pin package), External Clock Input Interrupt Source . . . Coincidence with Compare Register 2 <p>Timer Counter 3 : 8-Bit × 1 (Square-Wave Output, Event Count, Generation of Remote Control Carrier, Serial 0 Baud Rate Timer)</p> Clock Source . . . 1/4, 1/16 of System Clock, 1/1 of OSC Oscillation Clock, External Clock Input Interrupt Source . . . Coincidence with Compare Register 3 <p>Timer Counter 2, 3 can be cascade-connected.</p> <p>Timer Counter 4 : 16-Bit × 1 (Square-Wave/16-Bit PWM Output, Event Count, Synchronous Output Event, Input Capture)</p> Clock Source . . . 1/4, 1/16 of System Clock, 1/1 of OSC Oscillation Clock, External Clock Input Interrupt Source . . . Coincidence with Compare Register 4 <p>Time Base Timer (One-Minute Count Setting, Five independently operable 8-Bit Timer Counter)</p> Clock Source . . . 1/4 of System Clock, 1/1, 1/8192 of OSC Oscillation Clock, 1/1, 1/8192 of XI Oscillation Clock (Only 48-pin package) Interrupt Source . . . Coincidence with Compare Register 5, 1/8192 Prescaler Overflow <p>Watchdog Timer</p> Interrupt Source . . . 1/65536, 1/262144, 1/1048576 of System Clock (ROM Option)	
Serial Interface		<p>Serial 0 : 8-Bit × 1 (Synchronous Type/Simple UART{Half-Duplex})</p> Clock Source . . . 1/2, 1/4, 1/16 of System Clock . . . 1/2 of Timer Counter 3	
I/O Pins	I/O	27	• Common use 7 • Specified pull-up Resistor available • Input/Output selectable (bit unit) 26 (for 44-pin), 25 (for 42-pin)
	Input	12	• Common use • Specified pull-up Resistor available



A/D Inputs	10-Bit × 8ch (with S/H)
Special Ports	Buzzer Output, Remote Control Carrier Signal Output, High-Current Drive Port
Package	SDIP042-P-0600, QFP044-P-1010, TQFP048-P-0707B (under planning)
Electrical Characteristics	

Supply Current

Parameter	Symbol	Condition	Limit			Unit
			min	typ	max	
Operating Supply Current	IDD1	fosc = 20 MHz, VDD = 5 V			40	mA
	IDD2	fosc = 8 39 MHz, VDD = 5 V			18	mA
	IDD3	fx = 32 kHz, VDD = 3 V			100	μA
Supply Current at HALT1	IDD4	fx = 32 kHz, VDD = 3 V, Ta = 25 °C			8	μA
	IDD5	fx = 32 kHz, VDD = 3 V, Ta = -40 °C to +85 °C			18	μA
Supply Current at STOP	IDD6	VDD = 5 V, Ta = 25 °C			2	μA
		VDD = 5 V, Ta = -40 °C to +85 °C			20	μA

Support Tool

In-Circuit Emulator	PX-ICE101C / D + PX-PRB101C42-44QF10-C / D PX-ICE101C / D + PX-PRB101C42-42SD-C / D PX-ICE101C / D + PX-PRB101C42-48QF7-C / D
----------------------------	---

EPROM built-in Type	Type MN101CP427DP [ES (Engineering Sample) available] MN101CP427HT (under planning)
	ROM (× 8-Bit) 16 K
	RAM (× 8-Bit) 512
	Minimum Instruction Execution Time 0.10 μs (at 4.5 V to 5.5 V, 20 MHz) 0.25 μs (at 2.7 V to 5.5 V, 8 MHz)
	Package SDIP042-P-0600, QFP044-P-1010, TQFP048-P-0707B (under planning)

Pin Assignment

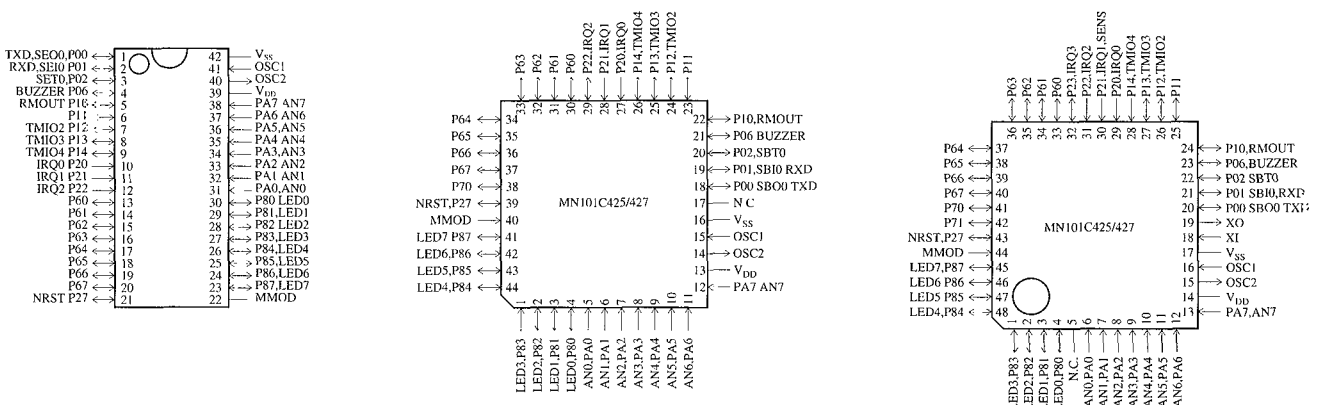

SDIP042-P-0600

QFP044-P-1010

TQFP048-P-0707B (under planning)