

# MN3112SA

## Vertical Driver for Video-Camera CCD Area-Image-Sensor

### ■ Overview

The MN3112SA is a vertical driver LSI incorporating four vertical driver channels and one sub driver channel for a 2-dimensional interline CCD image sensor.

The MN3112SA enables low current dissipation and the part reductions.

### ■ Features

- 3V power supply for input section

### ■ Applications

- Video cameras

### ■ Pin Assignment

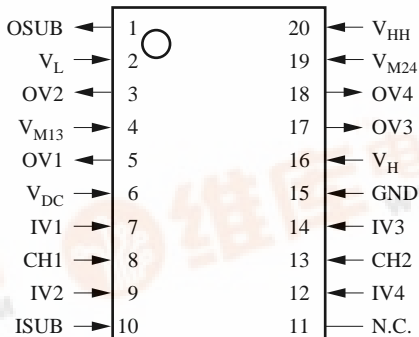

(TOP VIEW)

SSOP020-P-0225

■ Block Diagram

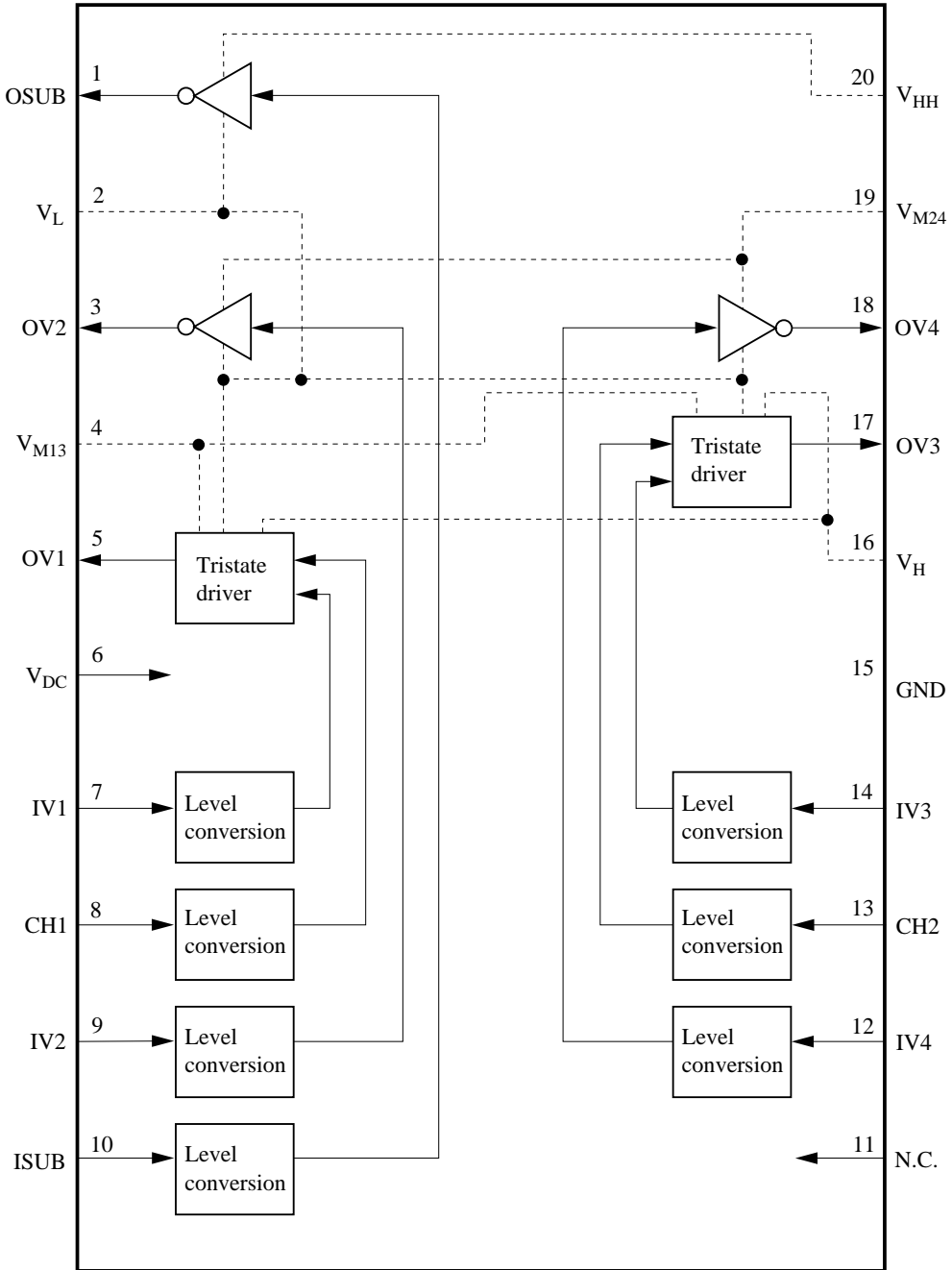

$V_{DC}$ ,  $V_L$ , GND : Common power supply

$V_{M13}$ ,  $V_{M24}$  : Binary and tristate independent power supplies for vertical driver section

$V_{HH}$ ,  $V_H$  : Independent power supplies for sub driver section and vertical driver section

### ■ Pin Descriptions

Pin No.	Symbol	Pin Name	I/O	Function Description
6	$V_{DC}$	Input section high-level power supply	I	5V high-level input
15	GND	Input section low-level power supply	I	5V low-level input
16	$V_H$	Vertical driver section high-level power supply	I	High-level input at high-voltage section
20	$V_{HH}$	SUB driver section high-level power supply	I	High-level input at high-voltage section
4 19	$V_{M13}$ $V_{M24}$	Middle-level power supply	I	Middle-level input at high-voltage section Input externally to both $V_{M13}$ and $V_{M24}$ .
2	$V_L$	Low-level power supply	I	Low-level input at high-voltage section
9	IV2	Transfer pulse input	I	Charge transfer pulse input pin
12	IV4	Transfer pulse input	I	Charge transfer pulse input pin
7	IV1	Transfer pulse input	I	Charge transfer pulse input pin
14	IV3	Transfer pulse input	I	Charge transfer pulse input pin
8	CH1	Charge pulse input	I	Charge read pulse input pin
13	CH1	Charge pulse input	I	Charge read pulse input pin
10	ISUB	SUB pulse input	I	Unwanted charge sourcing pulse input pin
18	OV4	Binary transfer pulse output	O	Binary transfer pulse output pin ( $V_{M24}, V_L$ )
3	OV2	Binary transfer pulse output	O	Binary transfer pulse output pin ( $V_{M24}, V_L$ )
17	OV3	Tristate transfer pulse output	O	Tristate transfer pulse output pin ( $V_H, V_{M13}, V_L$ )
5	OV1	Tristate transfer pulse output	O	Tristate transfer pulse output pin ( $V_H, V_{M13}, V_L$ )
1	OSUB	SUB pulse output	O	Unwanted charge sourcing pulse output pin ( $V_{HH}, V_L$ )
11	N.C.	No connection	—	

## ■ Functions

### Binary transfer pulse (vertical driver section)

IV2	OV2
IV4	OV4
H	L
L	M

### Tristate transfer pulse (vertical driver section)

CH1	IV1	OV1
CH2	IV3	OV3
H	H	L
	L	M
L	H	L
	L	H

\*1 IV1, IV2, IV3, IV4, CH1, CH2

H:  $V_{DC}$

L: GND

OV1, OV2, OV3, OV4

H:  $V_H$

M:  $V_{M13}$  or  $V_{M24}$

L:  $V_L$

### Unwanted charge sourcing pulse (SUB driver section)

ISUB	OSUB
H	L
L	H

\*1 ISUB

H:  $V_{DC}$

L: GND

OSUB

H:  $V_{HH}$

L:  $V_L$

## ■ Electrical Characteristics

### (1) DC characteristics

$V_{HH}=18.0V$  ,  $V_H=13.0V$  ,  $V_{M13}=V_{M24}=1.0V$  ,  $V_L=-7.0V$ ,

$V_{DC}=5.00V$  ,  $GND=0.0V$  ,  $T_a=-10^{\circ}C$  to  $+70^{\circ}C$

Parameter	Symbol	Test Conditions	min	typ	max	Unit
Quiescent supply current	$I_{DDST}$	$V_I=GND$ , $V_{DC}=3.0V$			2.5	mA
		$V_I=GND$ , $V_{DC}=5.0V$			4	
Operating supply current	$I_{DDYN}$	$V_I=GND$ , $V_{DC}$			7	mA
Input pins IV1 , IV2 , IV3 , IV4 , CH1 , CH2 , ISUB						
Voltage "H" level	$V_{IH}$		$0.7 \times V_{DC}$		$V_{DC}$	V
Voltage "L" level	$V_{IL}$		GND		$0.3 \times V_{DC}$	V
Input leakage current	$I_{LI}$	$V_I=0$ to $5V$			$\pm 1$	$\mu A$
Output pins 1 (binary output) OV2 , OV4						
Output voltage middle level	$V_{OM1}$	$I_{OM1}=-1mA$	0.9		$V_{M24}$	V
Output voltage "L" level	$V_{OL1}$	$I_{OL1}=1mA$	$V_L$		—	V
Output on-resistance middle level	$R_{ONM1}$	$I_{OM1}=-50mA$			40	$\Omega$
Output on-resistance "L" level	$R_{ONL1}$	$I_{OL1}=50mA$			40	$\Omega$
Output pins 2 (tristate output) OV1 , OV3						
Output voltage "H" level	$V_{OH2}$	$I_{OH2}=-1mA$	12.9		$V_H$	V
Output voltage middle level	$V_{OM2}$	$I_{OM2}=-1mA$	0.9		$V_{M13}$	V
Output voltage "L" level	$V_{OL2}$	$I_{OL2}=1mA$	$V_L$		—	V
Output on-resistance "H" level	$R_{ONH2}$	$I_{OH2}=-50mA$			50	$\Omega$
Output on-resistance middle level	$R_{ONM2}$	$I_{OM2}=\pm 50mA$			40	$\Omega$
Output on-resistance "L" level	$R_{ONL2}$	$I_{OL2}=50mA$			40	$\Omega$
Output pin 3 (SUB output) OSUB						
Output voltage "H" level	$V_{OHH3}$	$I_{OHH3}=-1mA$	17.9		$V_{HH}$	V
Output voltage "L" level	$V_{OL3}$	$I_{OL3}=1mA$	$V_L$		—	V
Output on-resistance middle level	$R_{ONHH3}$	$I_{ONHH3}=-50mA$			50	$\Omega$
Output on-resistance "L" level	$R_{ONL3}$	$I_{ONL3}=50mA$			40	$\Omega$

## (2) AC characteristics

 $V_{HH}=18.0V$  ,  $V_H=13.0V$  ,  $V_{M13}=V_{M24}=1.0V$  ,  $V_L=-7.0V$  ,

 $V_{DC}=3.0V$  ,  $GND=0.0V$  ,  $T_a=-10^{\circ}C$  to  $+70^{\circ}C$ 

Parameter	Symbol	Test Conditions	min	typ	max	Unit
Output pins 1 (binary output)		OV2 , OV4				
Transmission delay time	$t_{PLM}$ $t_{PML}$	No load "L" level — middle level		100	200	ns
Rise time	$t_{TLM}$			200	300	ns
Fall time	$t_{TML}$					
Output pins 2 (tristate output)		OV1 , OV3				
Transmission delay time	$t_{PLM}$ $t_{PML}$	No load "L" level — middle level		100	200	ns
Transmission delay time	$t_{TMH}$ $t_{THM}$	No load middle level — "H" level		200	400	ns
Rise time	$t_{TLM}$			200	300	ns
Fall time	$t_{TML}$					
Rise time	$t_{TMH}$			200	300	ns
Fall time	$t_{THM}$					
Output pin 3 (SUB output)		OSUB				
Transmission delay time	$t_{PLHH}$ $t_{PHHL}$	No load "L" level — "H" level		100	200	ns
Rise time	$t_{TLHH}$			200	300	ns
Fall time	$t_{THHL}$					

■ Application Circuit Example

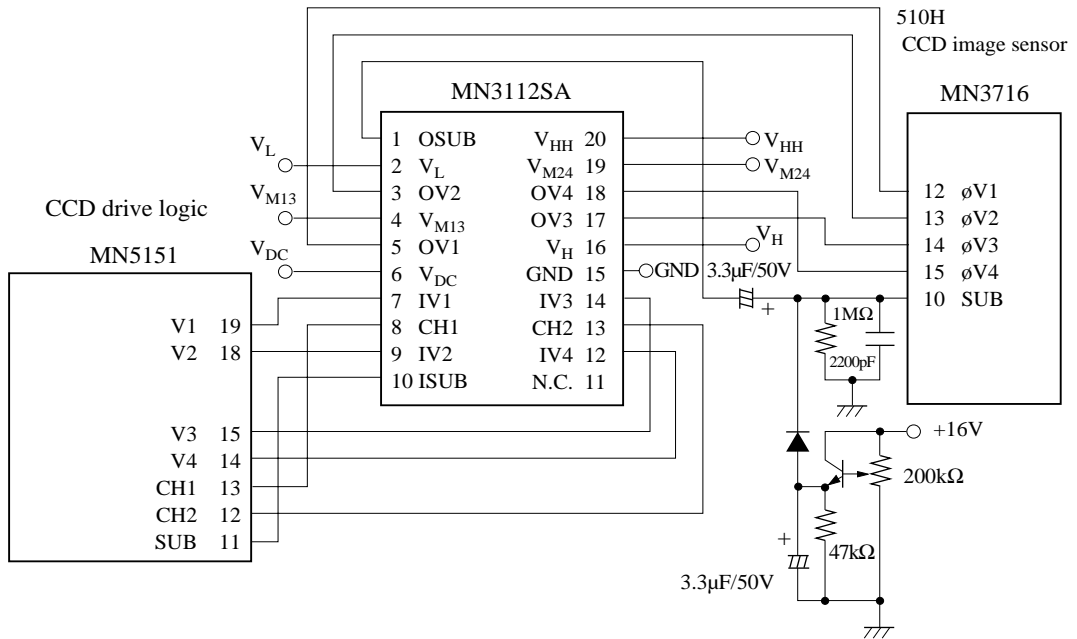

Note \*1: Connect a bypass capacitor as close as possible to each of the MN3112SA's power supply pins (V<sub>HH</sub>, V<sub>H</sub>, V<sub>M13</sub>, V<sub>M24</sub>, V<sub>L</sub>, V<sub>DC</sub>).

■ Package Dimensions (Unit: mm)

SSOP020-P-0225

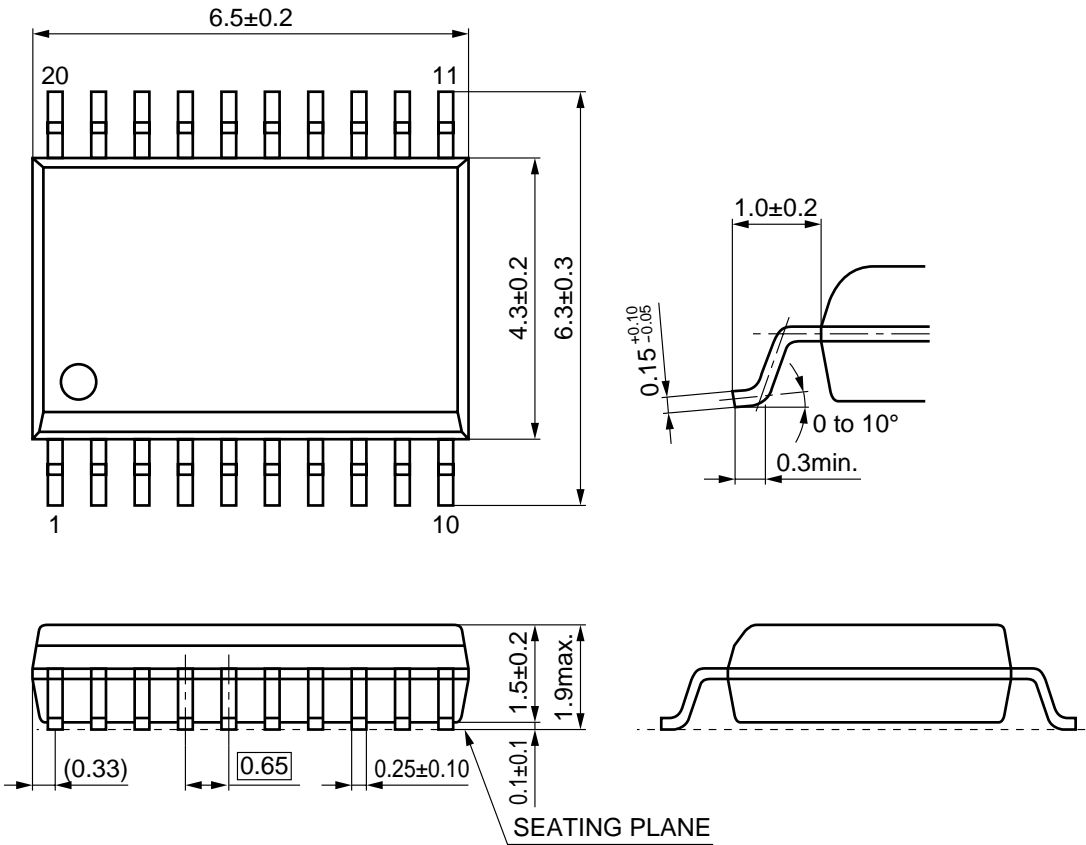



**■ Usage Notes**

- (1) When the sub driver is not used
  1. Connect  $V_{HH}$  (pin 20) to  $V_H$  (pin 16).
  2. Connect ISUB (pin 10) to  $V_{DC}$  (pin 6) or GND (pin 15).
  3. Make no connection for OSUB (pin 1).
- (2) Connect a bypass capacitor as close as possible to MN3112SA power supply pins  $V_{HH}$  (pin 20),  $V_H$  (pin 16),  $V_{M13}$  (pin 4),  $V_{M24}$  (pin 19),  $V_L$  (pin 2), and  $V_{DC}$  (pin 6).
- (3) Guarantee period after unsealing

The guarantee period after opening the dry-sealed packaging is three weeks under the environment conditions of 30°C/70% (temperature/humidity).
- (4) The recommended reflow temperature is 230°C.