

MN6311S

2K-Bit EEPROM

Overview

The MN6311S is a 2048-bit, bit sequential EEPROM with a built-in address counter. It sequentially increments the address with the clock input to produce serial output.

It includes a built-in charge pump circuit and timer for automatically erasing, writing, and modifying data using only a single 3 volt power supply.

To reduce write times, it includes a block write function for writing up to 32 bits at a time. This function makes it possible to rewrite the contents of all 2048 bits within 1 second (typ.).

Features

- 2048 words × 1 bit organization
- Built-in reset function
- Tristate output
- Low power consumption
 - 3 volt read: 1.5 mW (max.)
 - 3 volt program: 6 mW (max.)
 - 3 volt standby: 60 μW (max.)
- Single 3 volt power supply (charge pump circuit built-in)
- Self timer for use in automatically erasing and writing data
- Built-in data polling function
- Write cycles: 10⁵ times
- Data storage interval: 10 years

Applications

- Personal wireless equipment, cordless telephones, storage for recognition and adjustment data for terminals, etc.

Pin Assignment

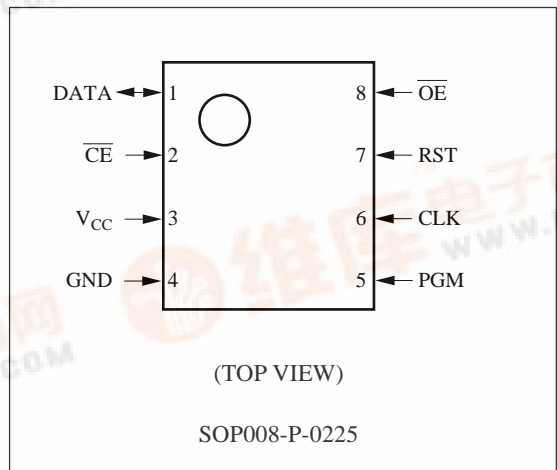

■ Block Diagram

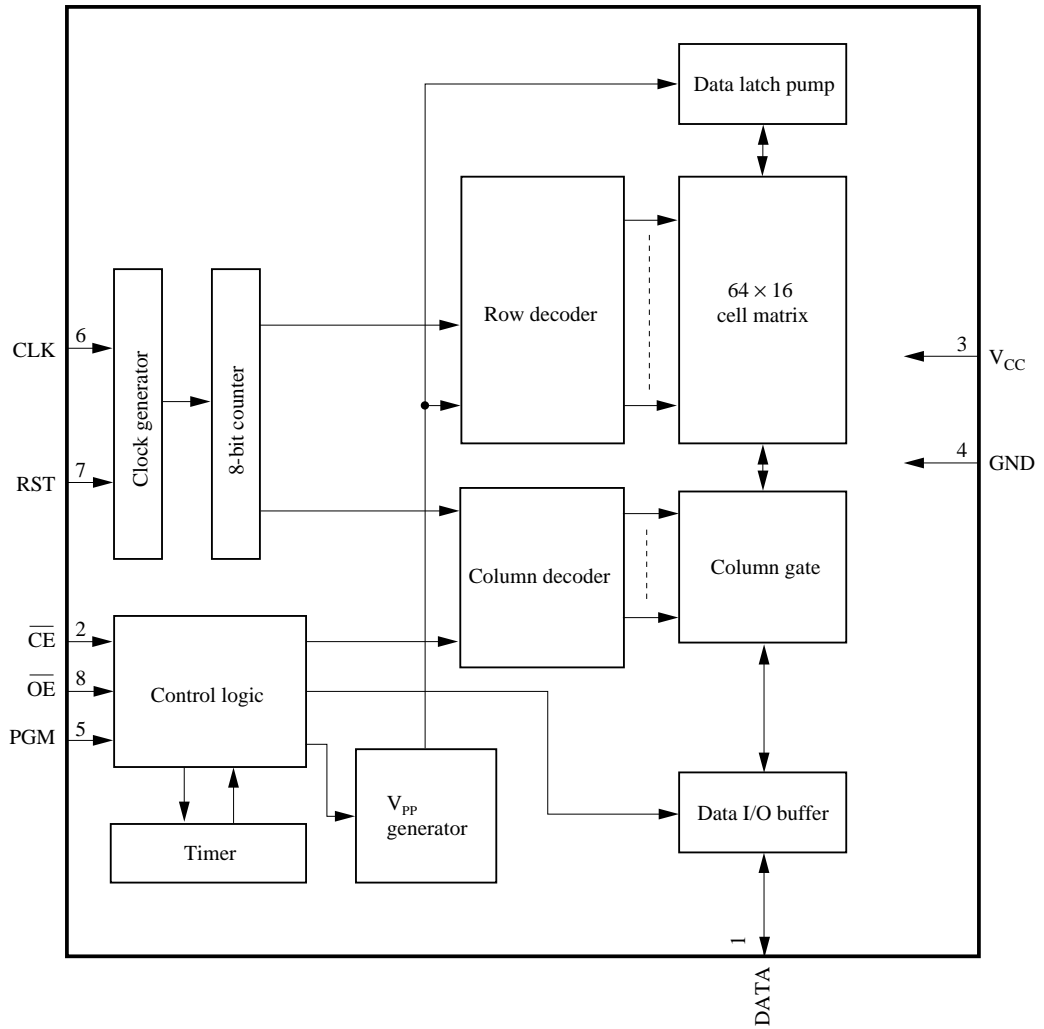

■ Pin Descriptions

Pin No.	Symbol	Pin Name
1	DATA	Data I/O
2	$\overline{\text{CE}}$	Chip enable
3	V_{CC}	Power supply voltage
4	GND	Ground
5	PGM	Program
6	CLK	Clock input
7	RST	Reset input
8	$\overline{\text{OE}}$	Output enable

■ Electrical Characteristics

$V_{\text{CC}}=2.6$ to 3.5V , $T_a=-10^\circ\text{C}$ to $+60^\circ\text{C}$

Parameter	Symbol	Test Conditions	3 Volt Operation		Unit
			min	max	
Power supply voltage	V_{CC}	Read mode	2.6	3.5	V
		Program mode	3.0	3.5	
"L" level input leakage current	I_{LIL}	$\overline{\text{CE}}$ pin	-50	—	μA
		Other pins	-10	10	
"H" level input leakage current	I_{LIH}	PGM, CLK, and RST pins	—	-20	μA
		Other pins	-10	10	
Output leakage current	I_{LO}		—	10	μA
"L" level input voltage	V_{IL}		-0.1 V_{CC}	0.2	V
"H" level input voltage	V_{IH}		0.8 V_{CC}	V_{CC} +0.3	V
V_{CC} power supply current (during operation)	I_{CC}	Read mode CLK;f=250kHz	—	500	μA
		Program mode	—	2000	
V_{CC} power supply current (during standby)	I_{SB}	$\overline{\text{CE}} = V_{\text{CC}} + 0.3\text{V}$; RST and PGM pins at V_{CC} ; CLK pin open	—	20	μA
"L" level output voltage	V_{OL}	$I_{\text{OL}}=400\ \mu\text{A}$	—	0.3	V
"H" level output voltage	V_{OH}	$I_{\text{OH}}=10\ \mu\text{A}$	V_{CC} -0.3	—	V

■ Function Descriptions

Operating Modes

Pin Symbol (Pin No.)	$\overline{\text{CE}}$ (2)	$\overline{\text{OE}}$ (8)	PGM (5)	DATA (1)
Operating Mode				
Read	V_{IL}	V_{IL}	×	D_{OUT}
Standby	V_{IH}	×	×	High-impedance
Program	V_{IL}	V_{IH}		D_{IN}

■ Package Dimensions (Unit:mm)

SOP008-P-0225

