

# MN676011NPS

## NTSC Color Camera Synchronizing Signal Generator LSI

### Overview

The MN676011NPS is a CMOS LSI that generates NTSC color camera synchronizing signals as defined by the EIA RS-170A standard.

It features a built-in  $4f_{SC}$  (14.31818 MHz) crystal oscillator circuit and divides that frequency to generate the horizontal synchronizing signal  $f_H$  (15.7 kHz), the vertical synchronizing signal  $f_V$  (60 Hz), and the composite synchronizing signal.

It also divides the  $4f_{SC}$  clock signal frequency by four to generate the color subcarrier frequency signals SC1 and SC2 and the burst signal gated with the burst flag (BF) pulse.

It includes a vertical reset (VR) input pin for resetting the leading edge of the vertical synchronizing pulse (VP) with the falling edge of the input signal. It also includes separate clock input pins for the color subcarrier frequency signal circuits and the synchronizing signal circuits to permit synchronization with such external synchronizing LSIs as the MN6761S.

### Features

- Power-saving CMOS synchronizing signal generator (conformed to EIA RS-170A standard)
- Built-in 14.31818 MHz clock generator
- 12 signal outputs including horizontal and vertical synchronizing signals and color subcarrier frequency signals (The vertical synchronizing signal is available as the VP signal output.)
- Pins for switching BLK signal pulse widths

### Applications

- Color video cameras

### Pin Assignment

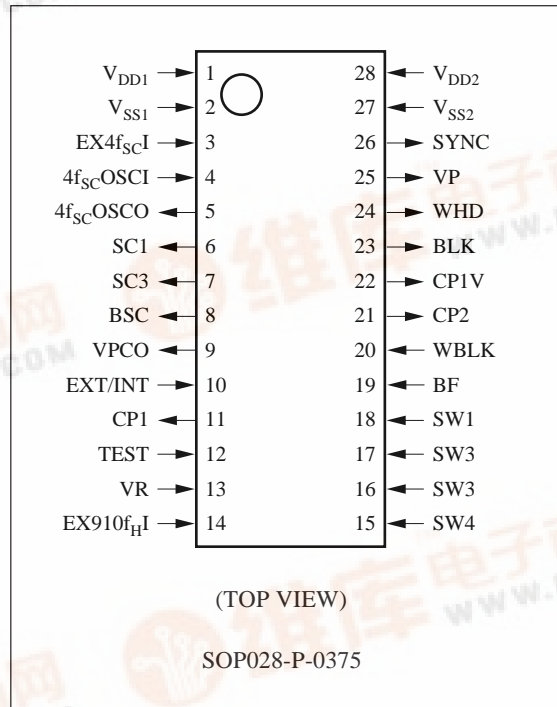

■ Block Diagram

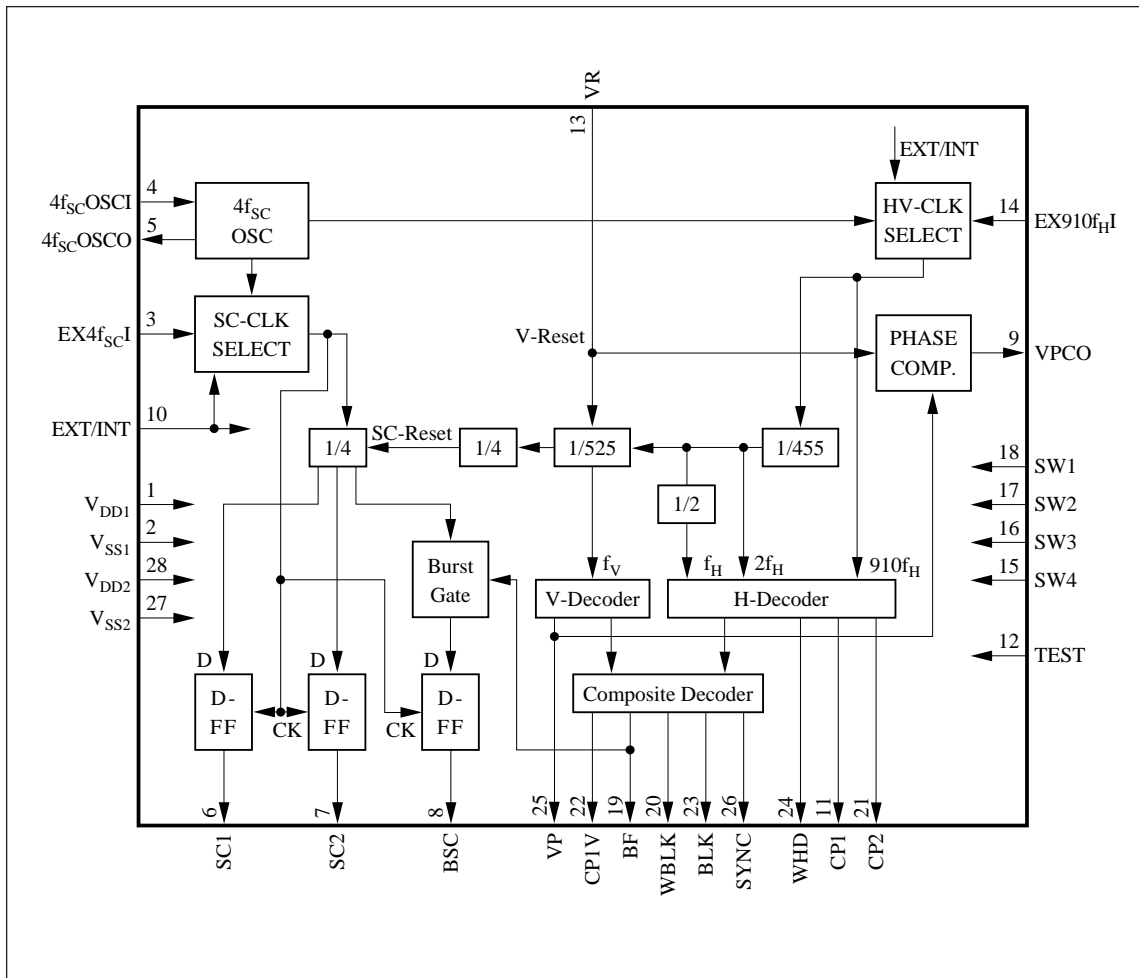

■ Pin Descriptions

Pin No.	Symbol	Pin Name	Function Description
1	$V_{DD1}$	Power supply	"H" level power supply (Connect this pin to +5.0 $\pm$ 0.5 V.) Power supply for color subcarrier frequency signal circuits
2	$V_{SS1}$	Power supply	"L" level power supply (Connect this pin to 0 V.) Power supply for color subcarrier frequency signal circuits
28	$V_{DD2}$	Power supply	"H" level power supply (Connect this pin to +5.0 $\pm$ 0.5 V.) Power supply for horizontal and vertical synchronizing signals
27	$V_{SS2}$	Power supply	"L" level power supply (Connect this pin to 0 V.) Power supply for horizontal and vertical synchronizing signals

■ Pin Descriptions (continued)

Pin No.	Symbol	Pin Name	Function Description															
4	4f <sub>SC</sub> OSCI	Crystal oscillator input	Connect these pins to a 14.31818-MHz crystal oscillator through capacitors appropriate for V <sub>SS1</sub> . "L" level input to the EXT/INT pin (which includes a built-in feedback resistor) produces oscillation; "H" level input stops it.															
5	4f <sub>SC</sub> OSCO	Crystal oscillator output																
3	EX4f <sub>SC</sub> I	External clock input	Color subcarrier frequency (4f <sub>SC</sub> ) input "H" level input to the EXT/INT pin enables external clock input. If this pin is not used, keep it at "L" level.															
14	EX910f <sub>H</sub> I	External clock input	External 910f <sub>H</sub> (14.31818 MHz) input for horizontal and vertical synchronizing signals "H" level input to the EXT/INT pin enables external clock input. If this pin is not used, keep it at "L" level.															
10	EXT/INT	External/internal synchronization switch input	This pin switches the chip between external and internal synchronization modes. "H" level input produces external synchronization; "L" level, internal synchronization. Incorporating pull-down resistor.															
13	VR	Vertical reset input	Falling edge input resets the leading edge of the vertical synchronizing signal (VP). The pin includes a built-in pull-up resistor.															
12	TEST	Test input	Test input Keep this pin at "H" level. The pin includes a built-in pull-up resistor.															
9	VPCO	Phase comparator output	This pin gives the results of comparing the phases of the falling edge of the VR input and rising edge of the VP output. The output is at "H" level when the VR leads the VP and is at "L" level when the VR trails the VP.															
18	SW1	H-BLK pulse width selection	<p>These pins control the widths of H-BLK and V-BLK pulses.</p> <table border="1"> <thead> <tr> <th>SW1</th> <th>SW2</th> <th>H-BLK (μs)</th> </tr> </thead> <tbody> <tr> <td>L</td> <td>L</td> <td>10.69</td> </tr> <tr> <td>H</td> <td>L</td> <td>10.82</td> </tr> <tr> <td>L</td> <td>H</td> <td>10.97</td> </tr> <tr> <td>H</td> <td>H</td> <td>11.10</td> </tr> </tbody> </table>	SW1	SW2	H-BLK (μs)	L	L	10.69	H	L	10.82	L	H	10.97	H	H	11.10
SW1	SW2			H-BLK (μs)														
L	L	10.69																
H	L	10.82																
L	H	10.97																
H	H	11.10																
17	SW2																	
16	SW3	V-BLK pulse width selection	<table border="1"> <thead> <tr> <th>SW3</th> <th>SW4</th> <th>V-BLK (H)</th> </tr> </thead> <tbody> <tr> <td>L</td> <td>L</td> <td>19</td> </tr> <tr> <td>H</td> <td>L</td> <td>20</td> </tr> <tr> <td>L</td> <td>H</td> <td>21</td> </tr> <tr> <td>H</td> <td>H</td> <td>21</td> </tr> </tbody> </table>	SW3	SW4	V-BLK (H)	L	L	19	H	L	20	L	H	21	H	H	21
SW3	SW4			V-BLK (H)														
L	L			19														
H	L			20														
L	H	21																
H	H	21																
15	SW4																	

■ Pin Descriptions (continued)

Pin No.	Symbol	Pin Name	Function Description
6	SC1	$f_{SC}$ (R-Y) output	Color subcarrier frequency signal (3.58 MHz) formed by dividing the crystal oscillator signal ( $4f_{SC}$ ) by four.
7	SC2	$f_{SC}$ (B-Y) output	Color subcarrier frequency signal (3.58 MHz) formed by dividing the crystal oscillator signal ( $4f_{SC}$ ) by four. This signal lags SC1 by 90°.
8	BSC	Burst output	Burst output signal If SC1 is the 180° signal, BSC is the 0° signal.
26	SYNC	Composite synchronizing signal output	Composite synchronizing signal
25	VP	Vertical synchronizing signal output	Vertical synchronizing signal output (width: 3H)
24	WHD	Wide HD output	Wide HD signal Preblanking signal with pulse width of 9.71 $\mu$ s
23	BLK	Composite blanking signal output	Composite blanking signal See the entries for SW1–SW4 for the pulse width.
22	CP1V	Composite clamp pulse output	Composite pulse for black level playback
21	CP2	Clamp pulse output	Clamp pulses for luminance and color difference signals Horizontal deflection start pulses
20	WBLK	Composite wide blanking output	Composite wide blanking signal This signal provides a horizontal blanking interval of 26.89 $\mu$ s and a vertical blanking interval of 134.5H
19	BF	Burst flag output	Gate signal for color subcarrier frequencies The pulse width is 2.51 $\mu$ s with the vertical interval (9H) dropped out.
11	CP1	Clamp pulse output	Pulse for black level playback

■ H Decoder Pulse Timing Diagram

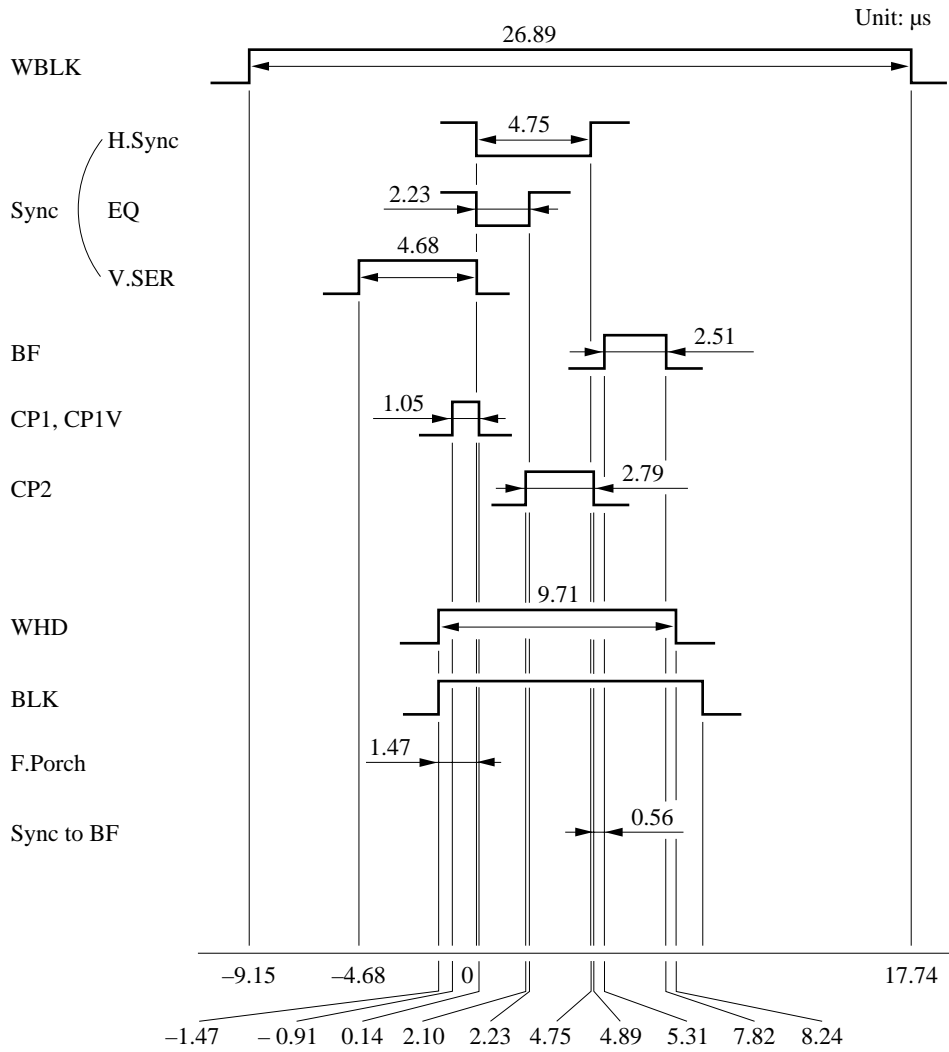

SW1	SW2	H-BLK ( $\mu\text{s}$ )
L	L	10.69
H	L	10.82
L	H	10.97
H	H	11.10

■ Pulse Timing Diagram for Composite and Vertical Synchronizing Signals

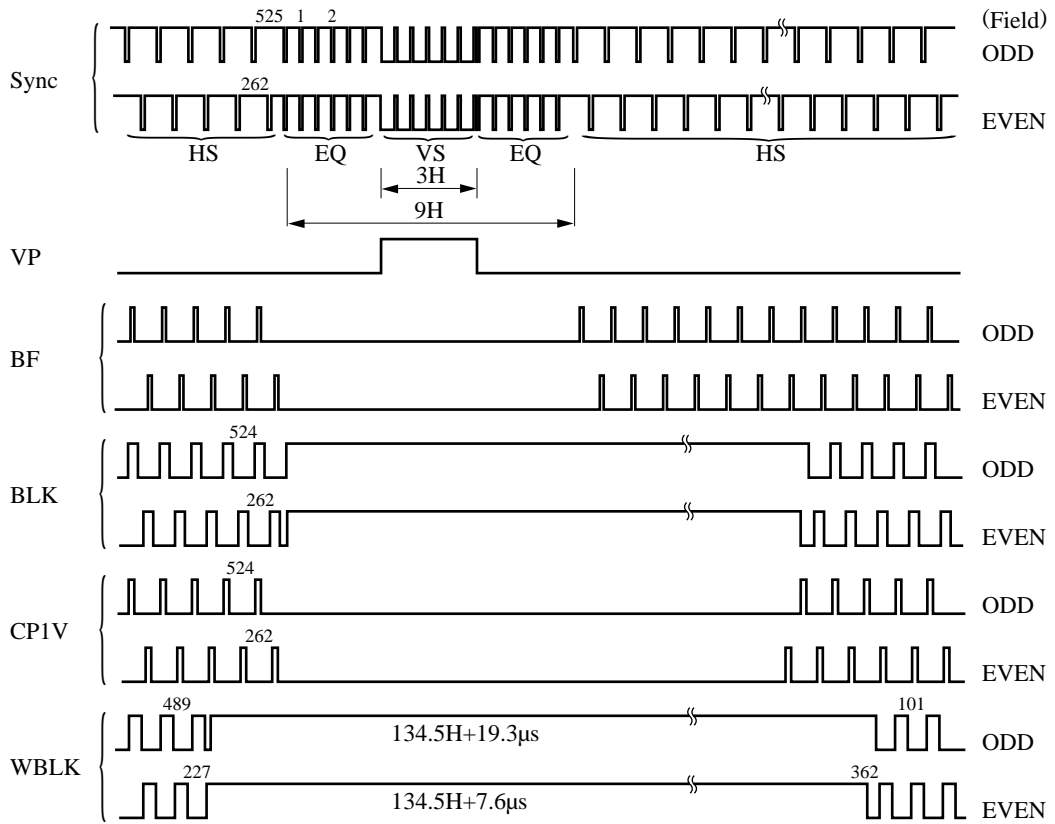

SW3	SW4	V-BLK (H)
L	L	19
H	L	20
L	H	21
H	H	21

■ Application Circuit Example

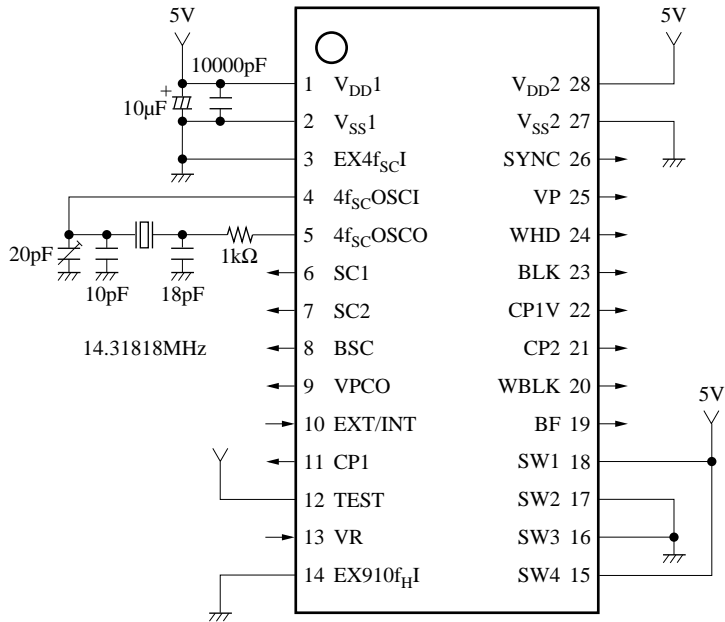

■ Package Dimensions (Unit: mm)

SOP028-P-0375

