

# MN83876A

## Liquid Crystal Display Panel Source Driver

### ■ Overview

The MN83876A converts digital display data from a personal computer or engineering workstation into analog signal voltages for driving thin-film transistor color LCD panels.

### ■ Features

- Driver capable of displaying 260,000 colors with built-in D/A converter accepting 6-bit digital inputs
- Choice of 300 or 309 drive outputs
- Seven-segment gamma correction
- Data settings of 01 and 3E in addition to 00, 07, 17, 27, 37, and 3F for output voltage inflection points
- Drive system that does not require precharging
- Supports serial cascade connections.
- Automatic clock suspension after reading in specified data volume
- Choice of shift register shift directions
- Support for data inversion control at the clock cycle level.
- Digital portions operate at low voltages (2.5 to 3.6 V)
- Maximum operating frequency of 55 MHz (2.5 to 3.6 V)
- Choice of 3.3 or 5 V for analog portions

### ■ Applications

- Personal computers and workstations (available for SVGA and XGA)

■ Block Diagram

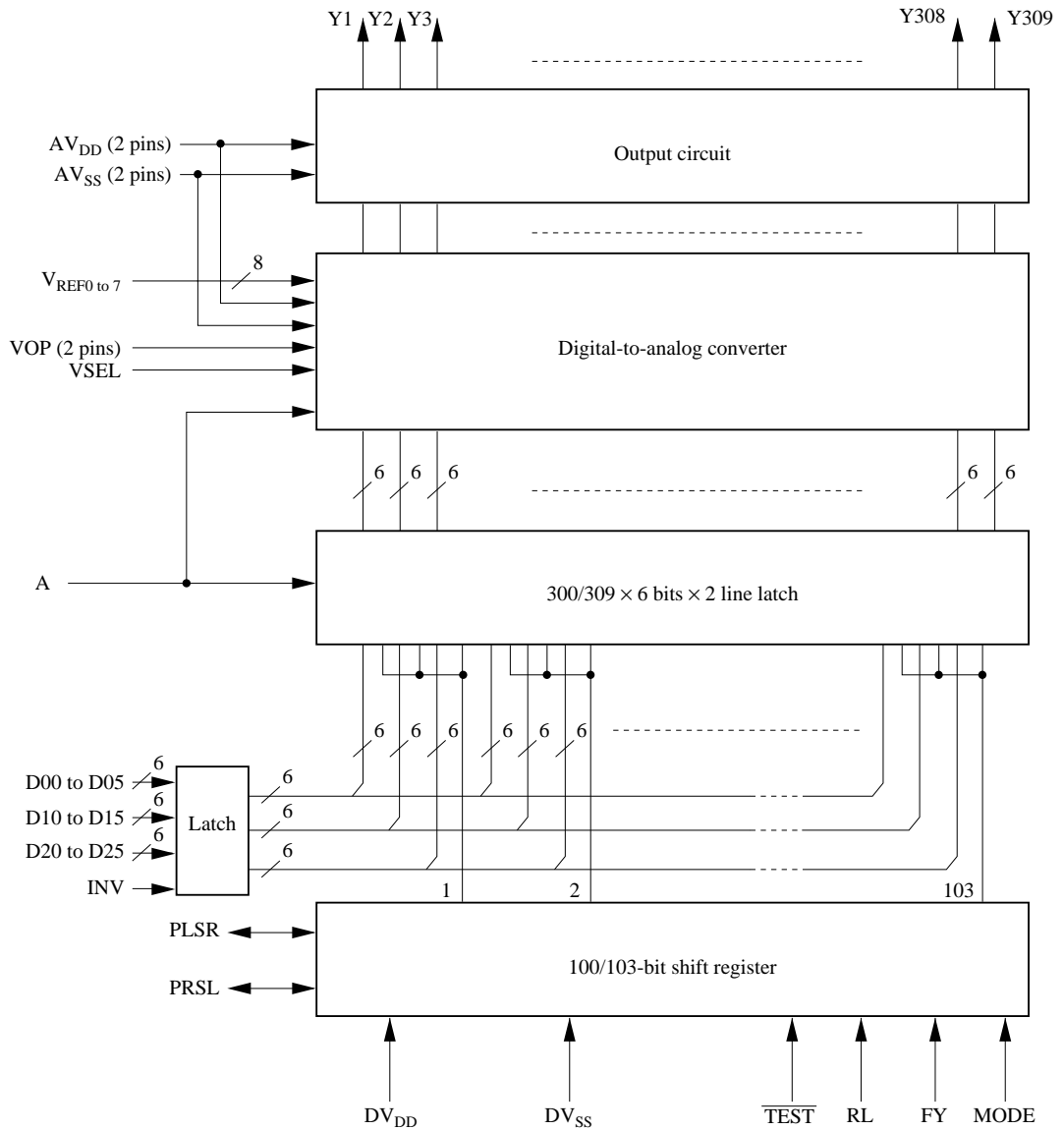

■ Application Circuit Example

