

# POWER OPTO™ Isolator

## 2 Amp Zero-Cross Triac Output

This device consists of a gallium arsenide infrared emitting diode optically coupled to a zero-cross triac driver circuit and a power triac. It is capable of driving a load of up to 2 amps (rms) directly, on line voltages from 20 to 280 volts ac (rms).

- Provides Normally Open Solid State AC Output with 2 Amp Rating
- 70 Amp Single Cycle Surge Capability
- Zero-Voltage Turn-on and Zero-Current Turn-off
- High Input-Output Isolation of 3750 vac (rms)
- Static dv/dt Rating of 400 Volts/μs Guaranteed
- 2 Amp Pilot Duty Rating Per UL508 ¶117 (Overload Test) and ¶118 (Endurance Test) [File No. 129224]
- CSA Approved [File No. CA77170-1].
- SEMKO Approved Certificate #9507228
- Exceeds NEMA 2-230 and IEEE472 Noise Immunity Test Requirements (See Fig.14)

### DEVICE RATINGS (T<sub>A</sub> = 25°C unless otherwise noted)

Rating	Symbol	Value	Unit
--------	--------	-------	------

#### INPUT LED

Forward Current — Maximum Continuous	I <sub>F</sub>	50	mA
Forward Current — Maximum Peak (PW = 100μs, 120 pps)	I <sub>F(pk)</sub>	1.0	A
Reverse Voltage — Maximum	V <sub>R</sub>	6.0	V

#### OUTPUT TRIAC

Output Terminal Voltage — Maximum Transient (1)	V <sub>DRM</sub>	600	V(pk)
Operating Voltage Range — Maximum Continuous (f = 47 – 63 Hz)	V <sub>T</sub>	20 to 280	Vac(rms)
On-State Current Range (Free Air, Power Factor ≥ 0.3)	I <sub>T(rms)</sub>	0.03 to 2.0	A
Non-Repetitive Single Cycle Surge Current — Maximum Peak (t = 16.7 ms)	I <sub>TSM</sub>	70	A
Main Terminal Fusing Current (t = 8.3 ms)	I <sup>2</sup> <sub>T</sub>	26	A <sup>2</sup> sec
Load Power Factor Range	PF	0.3 to 1.0	—
Junction Temperature Range	T <sub>J</sub>	- 40 to 125	°C

#### TOTAL DEVICE

Input-Output Isolation Voltage — Maximum(2) 47 – 63 Hz, 1 sec Duration	V <sub>ISO</sub>	3750	Vac(rms)
Thermal Resistance — Power Triac Junction to Case (See Fig. 15)	R <sub>θJC</sub>	8.0	°C/W
Ambient Operating Temperature Range	T <sub>oper</sub>	- 40 to +100	°C
Storage Temperature Range	T <sub>stg</sub>	- 40 to +150	°C
Lead Soldering Temperature — Maximum (1/16" from Case, 10 sec Duration)	T <sub>L</sub>	260	°C

1. Test voltages must be applied within dv/dt rating.
2. Input-Output isolation voltage, V<sub>ISO</sub>, is an internal device dielectric breakdown rating. For this test, pins 2, 3 and the heat tab are common, and pins 7 and 9 are common.

**MOC2A60-10**  
**MOC2A60-5\***

\*Motorola Preferred Device

**OPTOISOLATOR**  
**2 AMP ZERO CROSS**  
**TRIAC OUTPUT**  
**600 VOLTS**

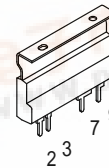

**CASE 417-02**  
**Style 2**  
 PLASTIC PACKAGE



**CASE 417A-02**  
**Style 1**  
 PLASTIC PACKAGE

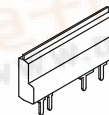

**CASE 417B-01**  
**Style 1**  
 PLASTIC PACKAGE

#### DEVICE SCHEMATIC

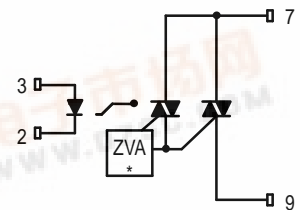

\* Zero Voltage Activate Circuit

- 1, 4, 5, 6, 8. NO PIN
2. LED CATHODE
3. LED ANODE
7. MAIN TERMINAL 2
9. MAIN TERMINAL 1

POWER OPTO is a trademark of Motorola, Inc.

Preferred devices are Motorola recommended choices for future use and best overall value.

# MOC2A60-10 MOC2A60-5

ELECTRICAL CHARACTERISTICS ( $T_A = 25^\circ\text{C}$  unless otherwise noted)

Characteristic	Symbol	Min	Typ	Max	Unit
----------------	--------	-----	-----	-----	------

## INPUT LED

Forward Voltage ( $I_F = 10\text{ mA}$ )	$V_F$	1.00	1.17	1.50	V
Reverse Leakage Current ( $V_R = 6.0\text{ V}$ )	$I_R$	—	1.0	100	$\mu\text{A}$
Capacitance	C	—	18	—	pF

## OUTPUT TRIAC

Off-State Leakage, Either Direction ( $I_F = 0, V_{\text{DRM}} = 600\text{ V}$ )	$I_{\text{DRM}}$	—	0.25	10	$\mu\text{A}$
Critical Rate of Rise of Off-State Voltage (Static) $V_{\text{in}} = 400\text{ vac(pk)}$ (1)(2)	$dv/dt(s)$	400	—	—	$\text{V}/\mu\text{s}$
Holding Current, Either Direction ( $I_F = 0, V_D = 12\text{ V}, I_T = 200\text{ mA}$ )	$I_H$	—	10	—	mA

## COUPLED

LED Trigger Current Required to Latch Output Either Direction (Main Terminal Voltage = 2.0 V)(3)(4)	MOC2A60-10 MOC2A60-5	$I_{\text{FT(on)}}$ $I_{\text{FT(on)}}$	— —	7.0 3.5	10 5.0	mA mA
On-State Voltage, Either Direction ( $I_F = \text{Rated } I_{\text{FT(on)}}, I_{\text{TM}} = 2.0\text{ A}$ )		$V_{\text{TM}}$	—	0.96	1.3	V
Inhibit Voltage, Either Direction ( $I_F = \text{Rated } I_{\text{FT(on)}}\text{)(5)}$ (Main Terminal Voltage above which device will not trigger)		$V_{\text{INH}}$	—	8.0	10	V
Commutating $dv/dt$ (Rated $V_{\text{DRM}}, I_T = 30\text{ mA} - 2.0\text{ A(rms)}$ , $T_A = -40 \pm 100^\circ\text{C}, f = 60\text{ Hz}$ )(2)		$dv/dt(c)$	5.0	—	—	$\text{V}/\mu\text{s}$
Common-mode Input-Output $dv/dt$ (2)		$dv/dt(cm)$	—	40,000	—	$\text{V}/\mu\text{s}$
Input-Output Capacitance ( $V = 0, f = 1.0\text{ MHz}$ )		$C_{\text{ISO}}$	—	1.3	—	pF
Isolation Resistance ( $V_{\text{I-O}} = 500\text{ V}$ )		$R_{\text{ISO}}$	$10^{12}$	$10^{14}$	—	$\Omega$

1. Per EIA/NARM standard RS-443, with  $V_P = 200\text{ V}$ , which is the instantaneous peak of the maximum operating voltage.
2. Additional  $dv/dt$  information, including test methods, can be found in Motorola applications note AN1048/D, Figure 43.
3. All devices are guaranteed to trigger at an  $I_F$  value less than or equal to the max  $I_{\text{FT}}$ . Therefore, the recommended operating  $I_F$  lies between the device's maximum  $I_{\text{FT(on)}}$  limit and the Maximum Rating of 50 mA.
4. Current-limiting resistor required in series with LED.
5. Also known as "Zero Voltage Turn-On."

## TYPICAL CHARACTERISTICS

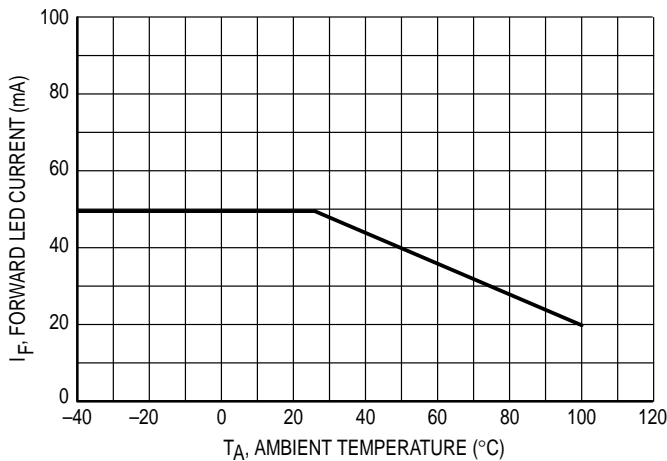

Figure 1. Maximum Allowable Forward LED Current versus Ambient Temperature

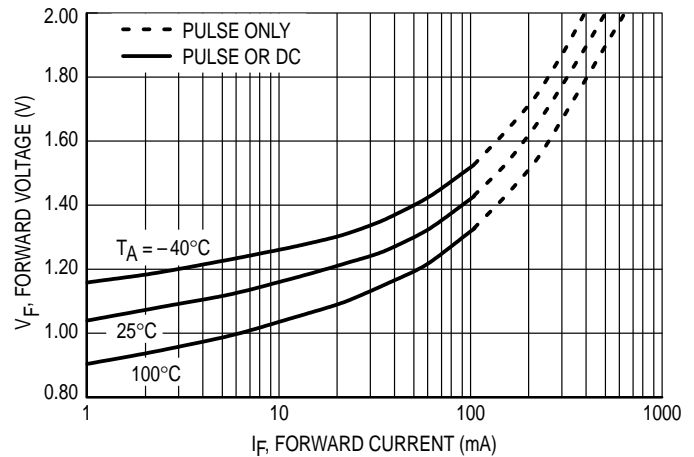
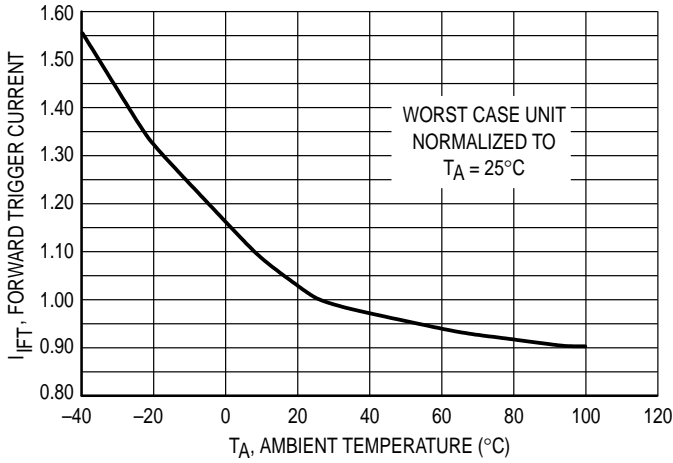
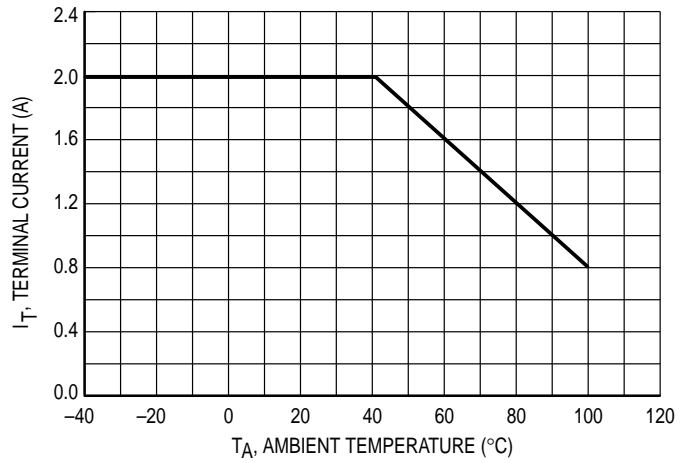

Figure 2. LED Forward Voltage versus LED Forward Current

# MOC2A60-10 MOC2A60-5



**Figure 3. Forward LED Trigger Current versus Ambient Temperature**



**Figure 4. Maximum Allowable On-State RMS Output Current (Free Air) versus Ambient Temperature**

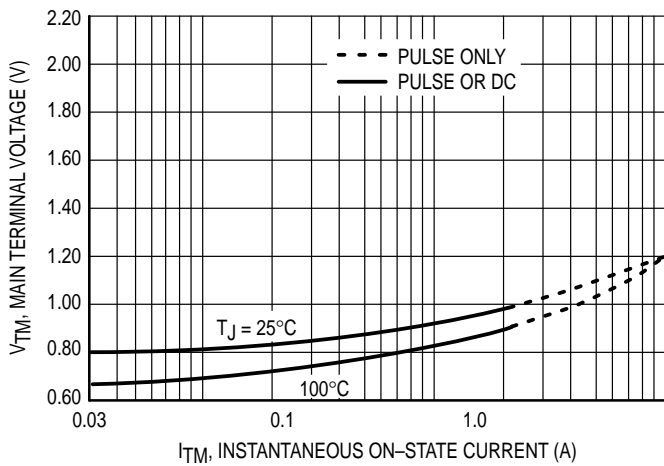

**Figure 5. On-State Voltage Drop versus Output Terminal Current**

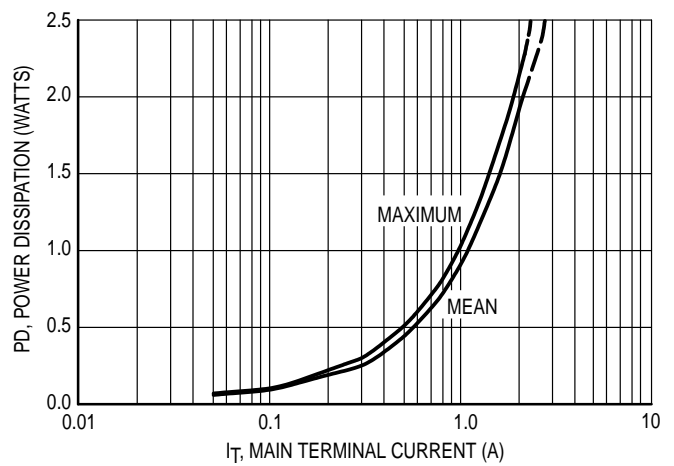

**Figure 6. Power Dissipation versus Main Terminal Current**

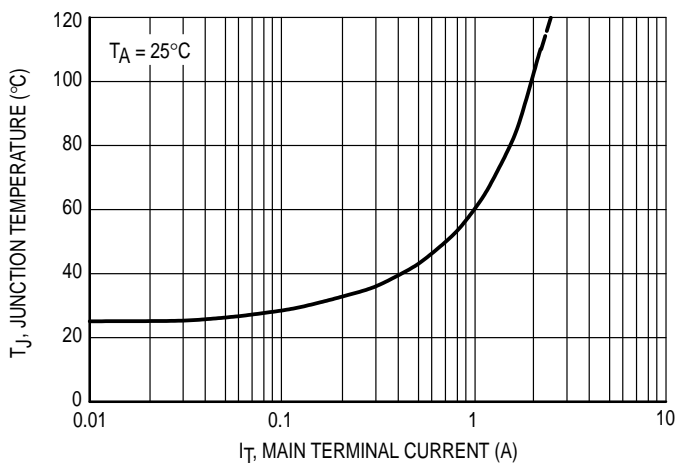

**Figure 7. Junction Temperature versus Main Terminal RMS Current (Free Air)**

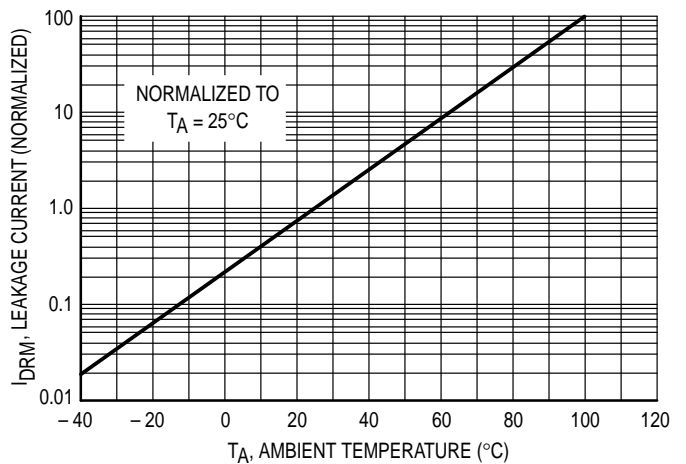

**Figure 8. Leakage with LED Off versus Ambient Temperature**

## MOC2A60-10 MOC2A60-5

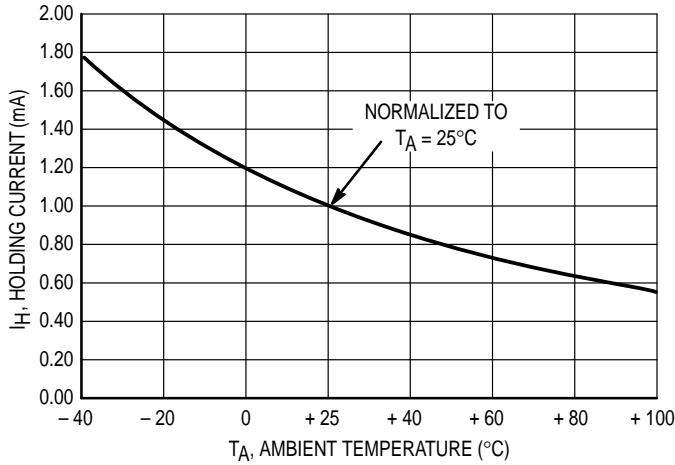

Figure 9. Holding Current versus Ambient Temperature

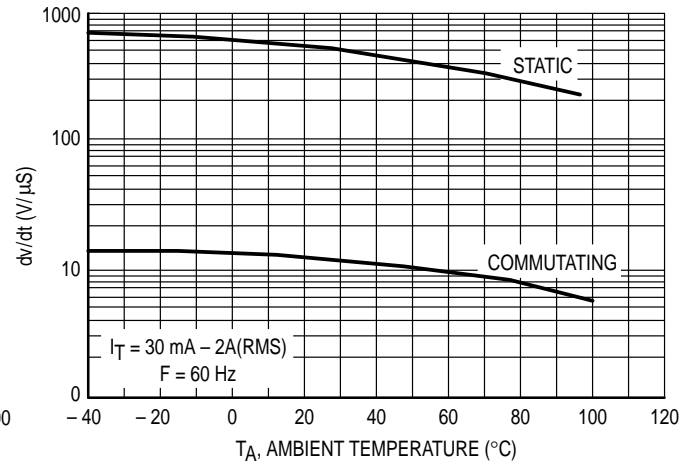

Figure 10. dv/dt versus Ambient Temperature

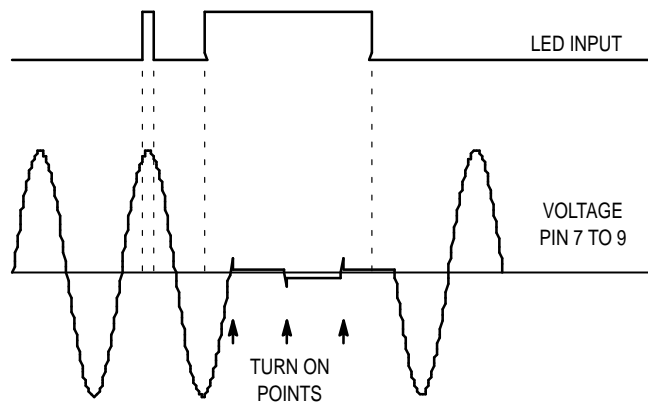

Figure 11. Operating Waveforms

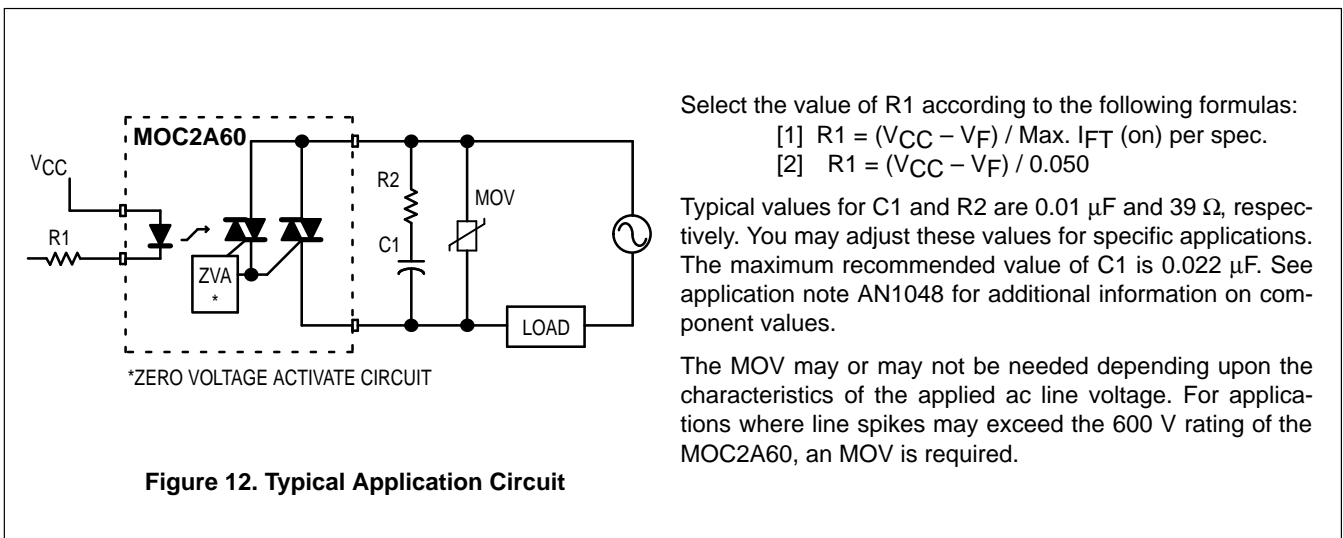

Figure 12. Typical Application Circuit

Select the value of R1 according to the following formulas:  
 [1]  $R1 = (V_{CC} - V_F) / \text{Max. } I_{FT}(\text{on}) \text{ per spec.}$   
 [2]  $R1 = (V_{CC} - V_F) / 0.050$

Typical values for C1 and R2 are 0.01  $\mu\text{F}$  and 39  $\Omega$ , respectively. You may adjust these values for specific applications. The maximum recommended value of C1 is 0.022  $\mu\text{F}$ . See application note AN1048 for additional information on component values.

The MOV may or may not be needed depending upon the characteristics of the applied ac line voltage. For applications where line spikes may exceed the 600 V rating of the MOC2A60, an MOV is required.

Use care to maintain the minimum spacings as shown. Safety and regulatory requirements dictate a minimum of 8.0 mm between the closest points between input and output conducting paths, Pins 3 and 7. Also, 0.070 inches distance is required between the two output Pins, 7 and 9.

Keep pad sizes on Pins 7 and 9 as large as possible for optimal performance.

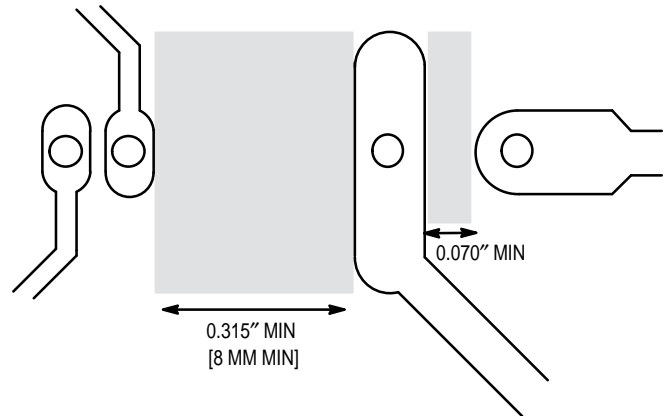

**Figure 13. PC Board Layout Recommendations**

Each device, when installed in the circuit shown in Figure 14, shall be capable of passing the following conducted noise tests:

- IEEE 472 (2.5 KV)
- Lamp Dimmer (NEMA Part DC33, § 3.4.2.1)
- NEMA ICS 2–230.45 Showering Arc
- MIL–STD–461A CS01, CS02 and CS06

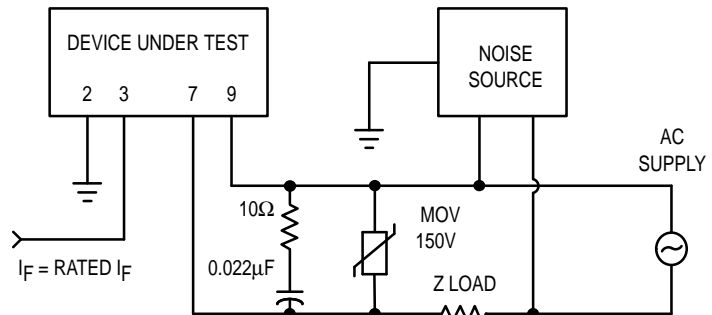

**Figure 14. Test Circuit for Conducted Noise Tests**

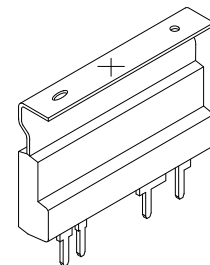
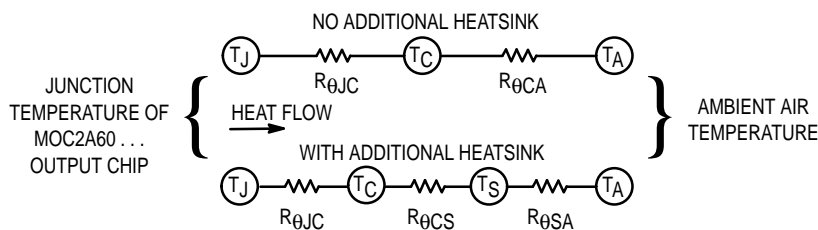

Thermal measurements of  $R_{\theta JC}$  are referenced to the point on the heat tab indicated with an 'X'. Measurements should be taken with device orientated along its vertical axis.

Terms in the model signify:

- $T_A$  = Ambient temperature
- $T_S$  = Optional additional heat sink temperature
- $T_C$  = Case temperature
- $T_J$  = Junction temperature
- $P_D$  = Power dissipation
- $R_{\theta SA}$  = Thermal resistance, heat sink to ambient
- $R_{\theta CA}$  = Thermal resistance, case to ambient
- $R_{\theta CS}$  = Thermal resistance, heat sink to case
- $R_{\theta JC}$  = Thermal resistance, junction to case

Values for thermal resistance components are:  $R_{\theta CA} = 36^\circ\text{C/W/in}$  maximum  
 $R_{\theta JC} = 8.0^\circ\text{C/W}$  maximum

The design of any additional heatsink will determine the values of  $R_{\theta SA}$  and  $R_{\theta CS}$ .

$$T_C - T_A = P_D (R_{\theta CA})$$

$$= P_D (R_{\theta JC} + R_{\theta SA}), \text{ where } P_D = \text{Power Dissipation in Watts.}$$

**Figure 15. Approximate Thermal Circuit Model**

# MOC2A60-10 MOC2A60-5

## PACKAGE DIMENSIONS

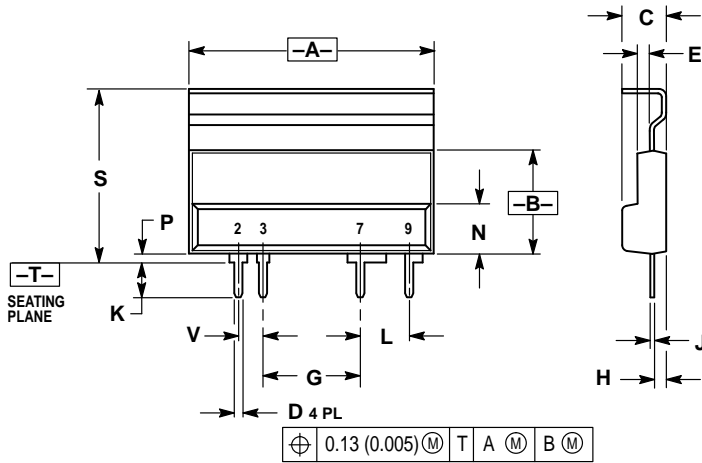

- NOTES:  
 1. DIMENSIONING AND TOLERANCING PER ANSI Y14.5M, 1982.  
 2. CONTROLLING DIMENSION: INCH.

DIM	INCHES		MILLIMETERS	
	MIN	MAX	MIN	MAX
A	0.965	1.005	24.51	25.53
B	0.416	0.436	10.57	11.07
C	0.170	0.190	4.32	4.83
D	0.025	0.035	0.64	0.89
E	0.040	0.060	1.02	1.52
G	0.400 BSC		10.16 BSC	
H	0.040	0.060	1.02	1.52
J	0.012	0.018	0.30	0.46
K	0.134	0.154	3.40	3.91
L	0.200 BSC		5.08 BSC	
N	0.190	0.210	4.83	5.33
P	0.023	0.043	0.58	1.09
S	0.695	0.715	17.65	18.16
V	0.100 BSC		2.54 BSC	

- STYLE 2:  
 PIN 2. LED CATHODE  
 3. LED ANODE  
 7. TRIAC MT  
 9. TRIAC MT

### CASE 417-02 PLASTIC STANDARD HEAT TAB ISSUE C

### ORDER "F" SUFFIX HEAT TAB OPTION (EX: MOC2A60-10F)

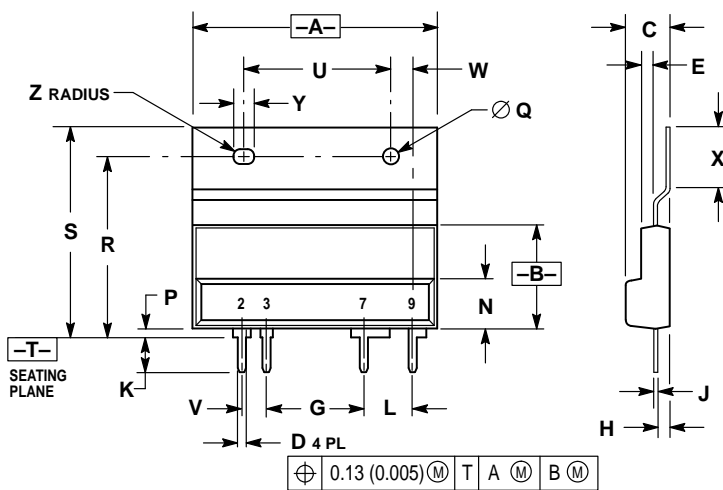

- NOTES:  
 1. DIMENSIONING AND TOLERANCING PER ANSI Y14.5M, 1982.  
 2. CONTROLLING DIMENSION: INCH.

DIM	INCHES		MILLIMETERS	
	MIN	MAX	MIN	MAX
A	0.965	1.005	24.51	25.53
B	0.416	0.436	10.57	11.07
C	0.170	0.190	4.32	4.83
D	0.025	0.035	0.64	0.89
E	0.040	0.060	1.02	1.52
G	0.400 BSC		10.16 BSC	
H	0.040	0.060	1.02	1.52
J	0.012	0.018	0.30	0.46
K	0.134	0.154	3.40	3.91
L	0.200 BSC		5.08 BSC	
N	0.190	0.210	4.83	5.33
P	0.023	0.043	0.58	1.09
Q	0.057	0.067	1.45	1.70
R	0.734	0.754	18.64	19.15
S	0.840	0.870	21.34	22.10
U	0.593	0.613	15.06	15.57
V	0.100 BSC		2.54 BSC	
W	0.074	0.094	1.88	2.39
X	0.265	0.295	6.73	7.49
Y	0.079	0.089	2.01	2.26
Z	0.026	0.036	0.66	0.91

- STYLE 1:  
 PIN 2. LED CATHODE  
 3. LED ANODE  
 7. TRIAC MT  
 9. TRIAC MT

### CASE 417A-02 PLASTIC FLUSH MOUNT HEAT TAB ISSUE A

# MOC2A60-10 MOC2A60-5

## PACKAGE DIMENSIONS — CONTINUED

ORDER "C" SUFFIX  
HEAT TAB OPTION  
(EX: MOC2A60-10C)

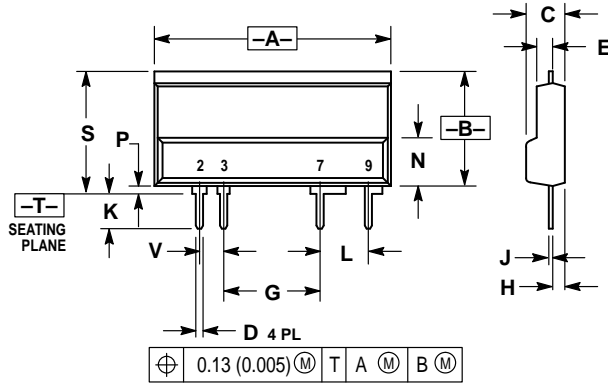

- NOTES:  
1. DIMENSIONING AND TOLERANCING PER ANSI Y14.5M, 1982.  
2. CONTROLLING DIMENSION: INCH.

DIM	INCHES		MILLIMETERS	
	MIN	MAX	MIN	MAX
A	0.965	1.005	24.51	25.53
B	0.416	0.436	10.57	11.07
C	0.170	0.190	4.32	4.83
D	0.025	0.035	0.64	0.89
E	0.040	0.060	1.02	1.52
G	0.400 BSC		10.16 BSC	
H	0.040	0.060	1.02	1.52
J	0.012	0.060	0.30	0.46
K	0.134	0.154	3.40	3.91
L	0.200 BSC		5.08 BSC	
N	0.190	0.210	4.83	5.33
P	0.023	0.043	0.58	1.09
S	0.439	0.529	11.15	13.44
V	0.100 BSC		2.54 BSC	

- STYLE 1:  
PIN 2. LED CATHODE  
3. LED ANODE  
7. TRIAC MT  
9. TRIAC MT

CASE 417B-01  
PLASTIC  
CUT HEAT TAB  
ISSUE O

## MOC2A60-10 MOC2A60-5

Motorola reserves the right to make changes without further notice to any products herein. Motorola makes no warranty, representation or guarantee regarding the suitability of its products for any particular purpose, nor does Motorola assume any liability arising out of the application or use of any product or circuit, and specifically disclaims any and all liability, including without limitation consequential or incidental damages. "Typical" parameters can and do vary in different applications. All operating parameters, including "Typicals" must be validated for each customer application by customer's technical experts. Motorola does not convey any license under its patent rights nor the rights of others. Motorola products are not designed, intended, or authorized for use as components in systems intended for surgical implant into the body, or other applications intended to support or sustain life, or for any other application in which the failure of the Motorola product could create a situation where personal injury or death may occur. Should Buyer purchase or use Motorola products for any such unintended or unauthorized application, Buyer shall indemnify and hold Motorola and its officers, employees, subsidiaries, affiliates, and distributors harmless against all claims, costs, damages, and expenses, and reasonable attorney fees arising out of, directly or indirectly, any claim of personal injury or death associated with such unintended or unauthorized use, even if such claim alleges that Motorola was negligent regarding the design or manufacture of the part. Motorola and  are registered trademarks of Motorola, Inc. Motorola, Inc. is an Equal Opportunity/Affirmative Action Employer.

### How to reach us:

**USA / EUROPE:** Motorola Literature Distribution;  
P.O. Box 20912; Phoenix, Arizona 85036. 1-800-441-2447

**JAPAN:** Nippon Motorola Ltd.; Tatsumi-SPD-JLDC, Toshikatsu Otsuki,  
6F Seibu-Butsuryu-Center, 3-14-2 Tatsumi Koto-Ku, Tokyo 135, Japan. 03-3521-8315

**MFAX:** RMFAX0@email.sps.mot.com – TOUCHTONE (602) 244-6609  
**INTERNET:** <http://Design-NET.com>

**HONG KONG:** Motorola Semiconductors H.K. Ltd.; 8B Tai Ping Industrial Park,  
51 Ting Kok Road, Tai Po, N.T., Hong Kong. 852-26629298

