

FAIRCHILD
SEMICONDUCTOR®

6-PIN DIP ZERO-CROSS OPTOISOLATORS TRIAC DRIVER OUTPUT (800 VOLT PEAK)

MOC3081M

MOC3082M

MOC3083M

PACKAGE

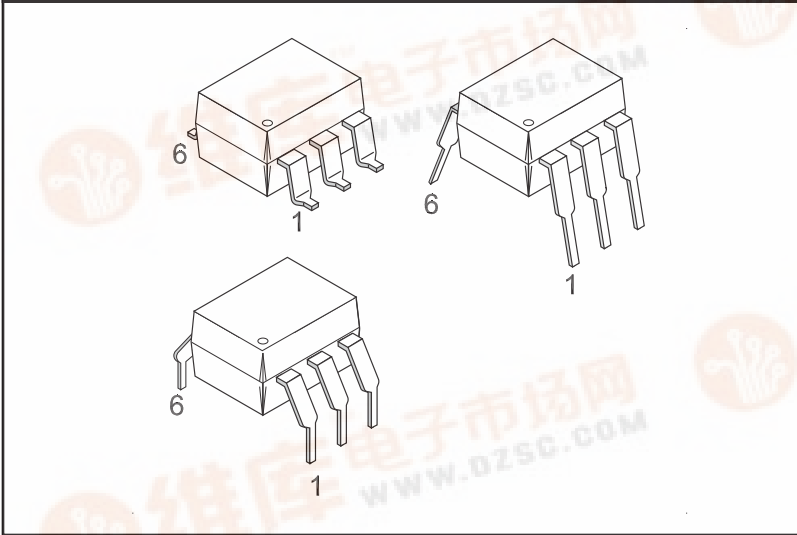

SCHEMATIC

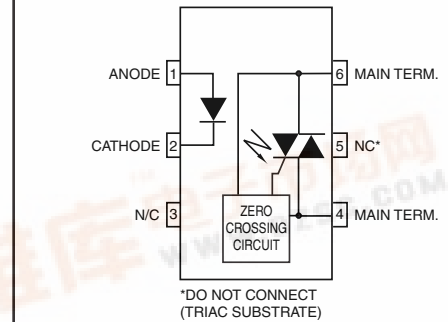

DESCRIPTION

The MOC3081M, MOC3082M and MOC3083M devices consist of a GaAs infrared emitting diode optically coupled to a monolithic silicon detector performing the function of a zero voltage crossing bilateral triac driver.

They are designed for use with a discrete power triac in the interface of logic systems to equipment powered from 240 VAC lines, such as solid-state relays, industrial controls, motors, solenoids and consumer appliances, etc.

FEATURES

- Underwriters Laboratories (UL) recognized - file #E90700, Volume 2
- VDE recognized - file #102497 - add option V (e.g., MOC3083VM)
- Simplifies logic control of 240 VAC power
- Zero voltage crossing
- dv/dt of 1500 V/ μs typical, 600 V/ μs guaranteed
- Compatible with Fairchild's FKPF12N80 discrete power triac

APPLICATIONS

- Solenoid/valve controls
- Lighting controls
- Static power switches
- AC motor drives
- Temperature controls
- E.M. contactors
- AC motor starters
- Solid state relays

MOC3081M

MOC3082M

MOC3083M

ABSOLUTE MAXIMUM RATINGS ($T_A = 25^\circ\text{C}$ unless otherwise noted)			
Parameters	Symbol	Value	Units
TOTAL DEVICE			
Storage Temperature	T_{STG}	-40 to +150	$^\circ\text{C}$
Operating Temperature	T_{OPR}	-40 to +85	$^\circ\text{C}$
Lead Solder Temperature	T_{SOL}	260 for 10 sec	$^\circ\text{C}$
Junction Temperature Range	T_J	-40 to +100	$^\circ\text{C}$
Isolation Surge Voltage ⁽⁴⁾ (peak AC voltage, 60Hz, 1 sec duration)	V_{ISO}	7500	Vac(pk)
Total Device Power Dissipation @ 25°C Derate above 25°C	P_D	250	mW
		2.94	mW/ $^\circ\text{C}$
EMITTER			
Continuous Forward Current	I_F	60	mA
Reverse Voltage	V_R	6	V
Total Power Dissipation 25°C Ambient Derate above 25°C	P_D	120	mW
		1.41	mW/ $^\circ\text{C}$
DETECTOR			
Off-State Output Terminal Voltage	V_{DRM}	800	V
Peak Repetitive Surge Current (PW = 100 μs , 120 pps)	I_{TSM}	1	A
Total Power Dissipation @ 25°C Ambient Derate above 25°C	P_D	150	mW
		1.76	mW/ $^\circ\text{C}$

MOC3081M

MOC3082M

MOC3083M

ELECTRICAL CHARACTERISTICS ($T_A = 25^\circ\text{C}$ Unless otherwise specified)

INDIVIDUAL COMPONENT CHARACTERISTICS

Parameters	Test Conditions	Symbol	Min	Typ*	Max	Units
EMITTER						
Input Forward Voltage	$I_F = 30\text{ mA}$	V_F		1.3	1.5	V
Reverse Leakage Current	$V_R = 6\text{ V}$	I_R		0.005	100	μA
DETECTOR						
Peak Blocking Current, Either Direction	$V_{\text{DRM}} = 800\text{V}$, $I_F = 0$ (note 1)	I_{DRM1}		10	500	nA
Critical Rate of Rise of Off-State Voltage	$I_F = 0$ (figure 9, note 3)	dv/dt	600	1500		V/ μs

TRANSFER CHARACTERISTICS ($T_A = 25^\circ\text{C}$ Unless otherwise specified.)

DC Characteristics	Test Conditions	Symbol	Device	Min	Typ*	Max	Units
LED Trigger Current	Main Terminal Voltage = 3V (note 2)	I_{FT}	MOC3081M			15	mA
			MOC3082M			10	
			MOC3083M			5	
Peak On-State Voltage, Either Direction	$I_{\text{TM}} = 100\text{ mA peak}$, $I_F = \text{rated } I_{\text{FT}}$	V_{TM}	All		1.8	3	V
Holding Current, Either Direction		I_H	All		500		μA

ZERO CROSSING CHARACTERISTICS ($T_A = 25^\circ\text{C}$ Unless otherwise specified.)

DC Characteristics	Test Conditions	Symbol	Device	Min	Typ*	Max	Units
Inhibit Voltage (MT1-MT2 voltage above which device will not trigger)	$I_F = \text{Rated } I_{\text{FT}}$	V_{INH}	All		12	20	V
Leakage in Inhibited State	$I_F = \text{Rated } I_{\text{FT}}$, $V_{\text{DRM}} = 800\text{V}$, off state	I_{DRM2}	All		200	500	μA

ISOLATION CHARACTERISTICS

Characteristics	Test Conditions	Symbol	Min	Typ*	Max	Units
Input-Output Isolation Voltage	f = 60 Hz, t = 1 sec (note 4)	V_{ISO}	7500			Vac(pk)

*Typical values at $T_A = 25^\circ\text{C}$

Note

- Test voltage must be applied within dv/dt rating.
- All devices are guaranteed to trigger at an I_F value less than or equal to max I_{FT} . Therefore, recommended operating I_F lies between max I_{FT} (15 mA for MOC3081M, 10 mA for MOC3082M, 5 mA for MOC3083M) and absolute max I_F (60 mA).
- This is static dv/dt. See Figure 9 for test circuit. Commutating dv/dt is a function of the load-driving thyristor(s) only.
- Isolation surge voltage, V_{ISO} , is an internal device dielectric breakdown rating. For this test, Pins 1 and 2 are common, and Pins 4, 5 and 6 are common.

MOC3081M

MOC3082M

MOC3083M

Figure 1. LED Forward Voltage vs. Forward Current

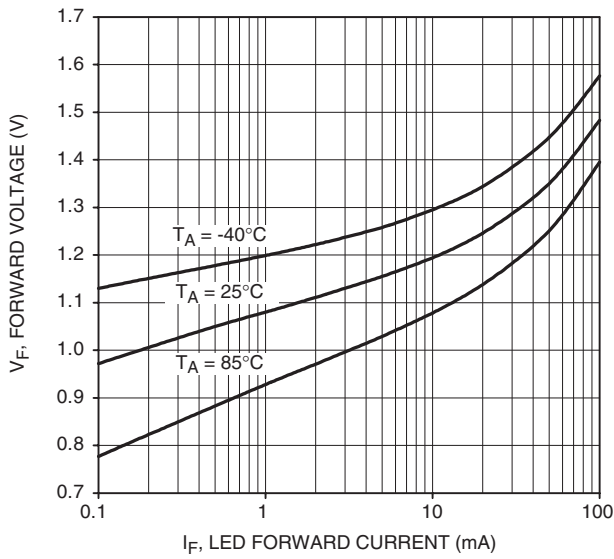

Figure 2. Trigger Current Vs. Temperature

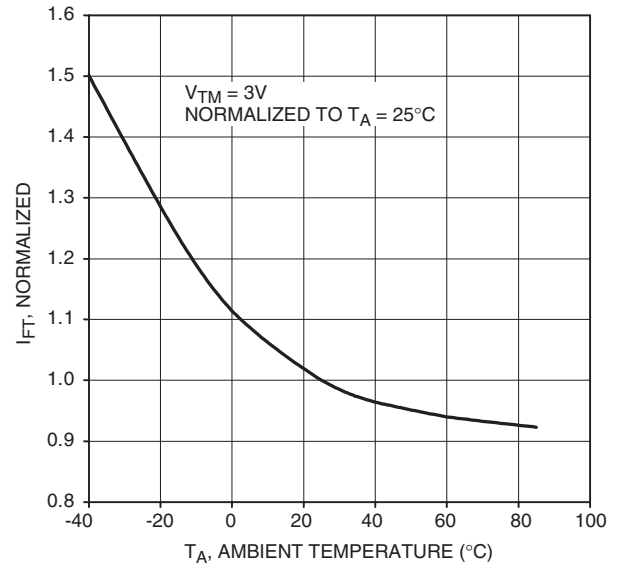

Figure 3. LED Current Required to Trigger vs. LED Pulse Width

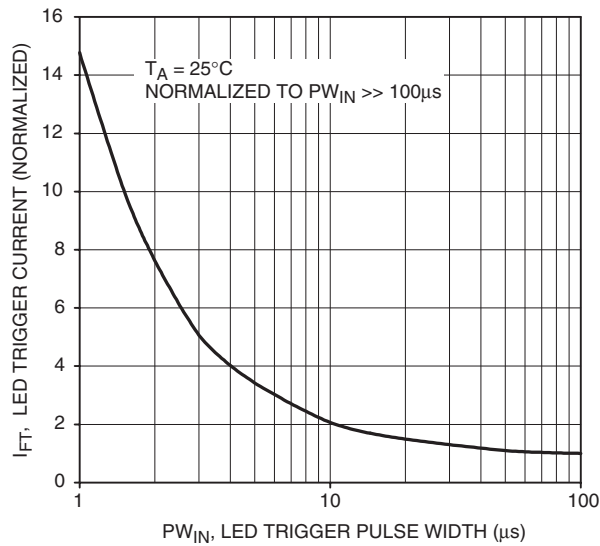
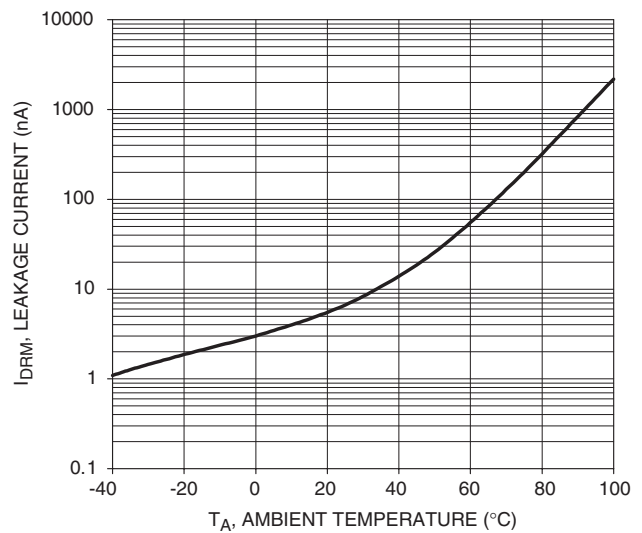

Figure 4. Leakage Current, I_{DRM} vs. Temperature



MOC3081M

MOC3082M

MOC3083M

Figure 5. I_{DRM2} , Leakage in Inhibit State vs. Temperature

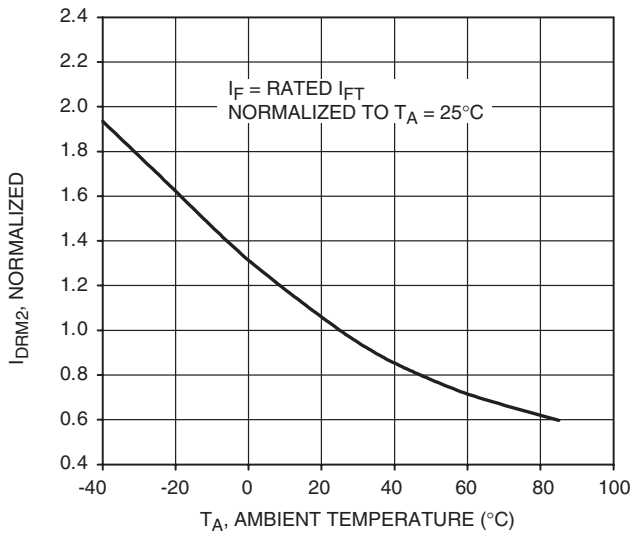

Figure 6. On-State Characteristics

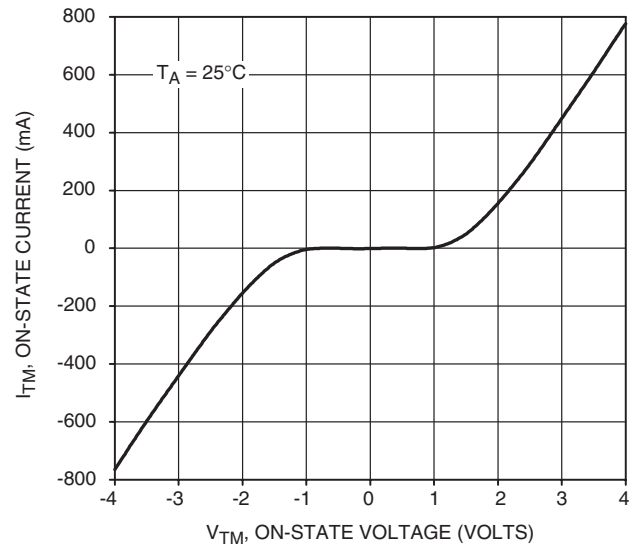

Figure 7. I_H , Holding Current vs. Temperature

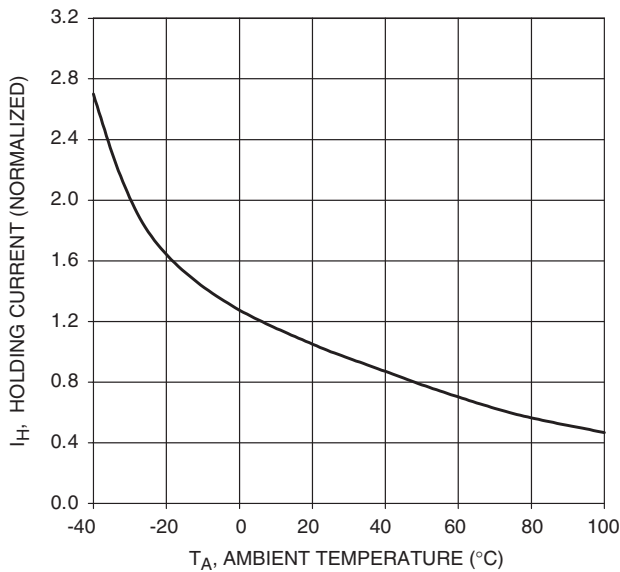
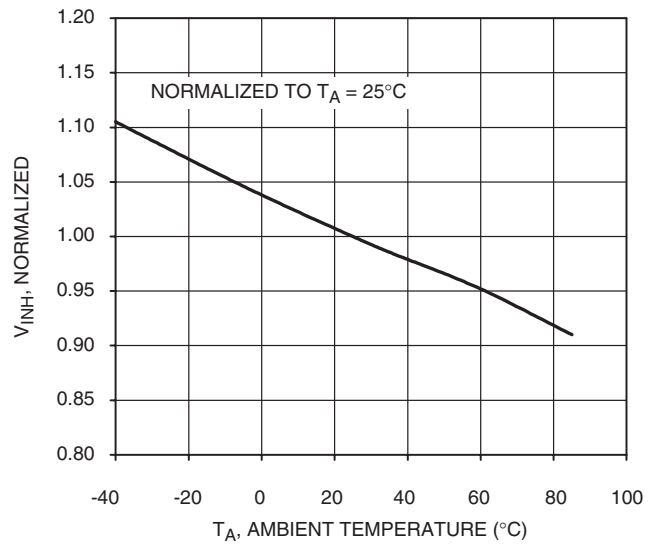

Figure 8. Inhibit Voltage vs. Temperature



MOC3081M

MOC3082M

MOC3083M

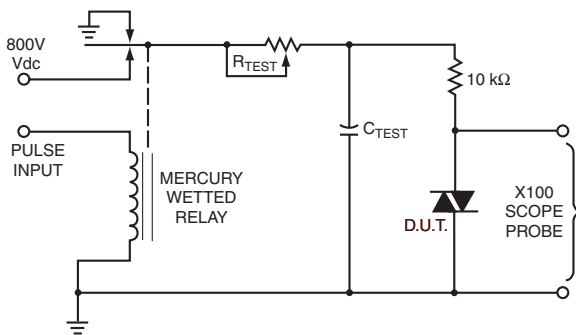

Figure 9. Static dv/dt Test Circuit

1. The mercury wetted relay provides a high speed repeated pulse to the D.U.T.
2. 100x scope probes are used, to allow high speeds and voltages.
3. The worst-case condition for static dv/dt is established by triggering the D.U.T. with a normal LED input current, then removing the current. The variable R_{TEST} allows the dv/dt to be gradually increased until the D.U.T. continues to trigger in response to the applied voltage pulse, even after the LED current has been removed. The dv/dt is then decreased until the D.U.T. stops triggering. τ_{RC} is measured at this point and recorded.

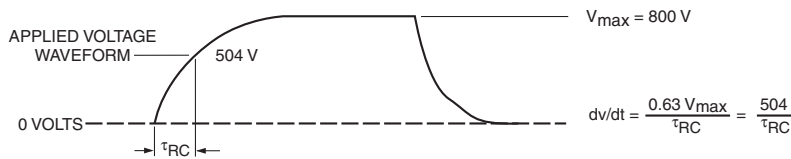
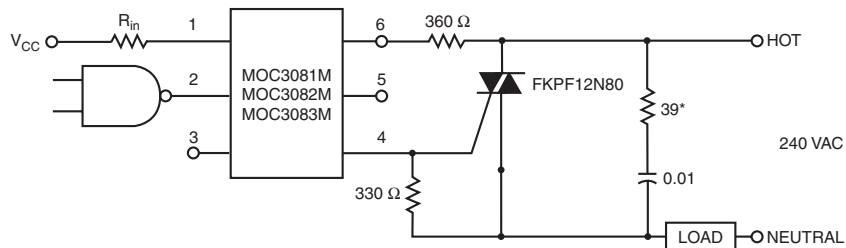

Figure 10. Static dv/dt Test Waveform

Typical circuit for use when hot line switching is required. In this circuit the “hot” side of the line is switched and the load connected to the cold or neutral side. The load may be connected to either the neutral or hot line.

R_{in} is calculated so that I_F is equal to the rated I_{FT} of the part, 15 mA for the MOC3081M, 10 mA for the MOC3082M, and 5 mA for the MOC3083M. The 39 ohm resistor and 0.01 μF capacitor are for snubbing of the triac and may or may not be necessary depending upon the particular triac and load use.



* For highly inductive loads (power factor < 0.5), change this value to 360 ohms.

Figure 11. Hot-Line Switching Application Circuit

MOC3081M

MOC3082M

MOC3083M

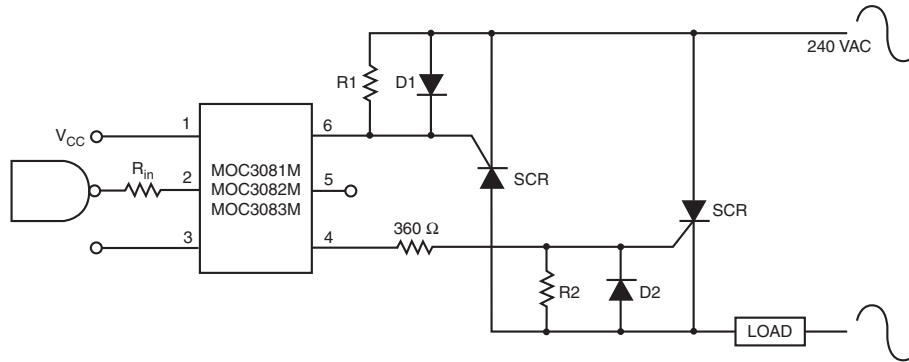

Figure 12. Inverse-Parallel SCR Driver Circuit

Suggested method of firing two, back-to-back SCR's with a Fairchild triac driver. Diodes can be 1N4001; resistors, R1 and R2, are optional 330 ohm.

Note: This optoisolator should not be used to drive a load directly. It is intended to be a trigger device only.

MOC3081M

MOC3082M

MOC3083M

Package Dimensions (Through Hole)

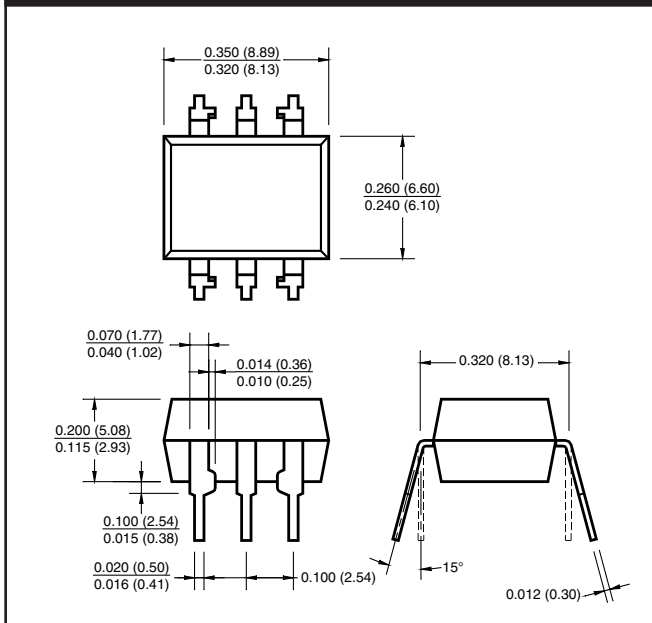

Package Dimensions (Surface Mount)

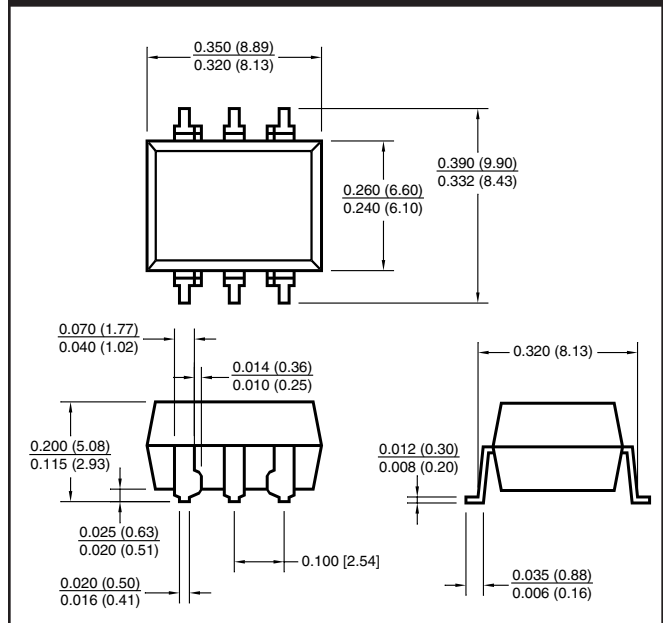

Package Dimensions (0.4" Lead Spacing)

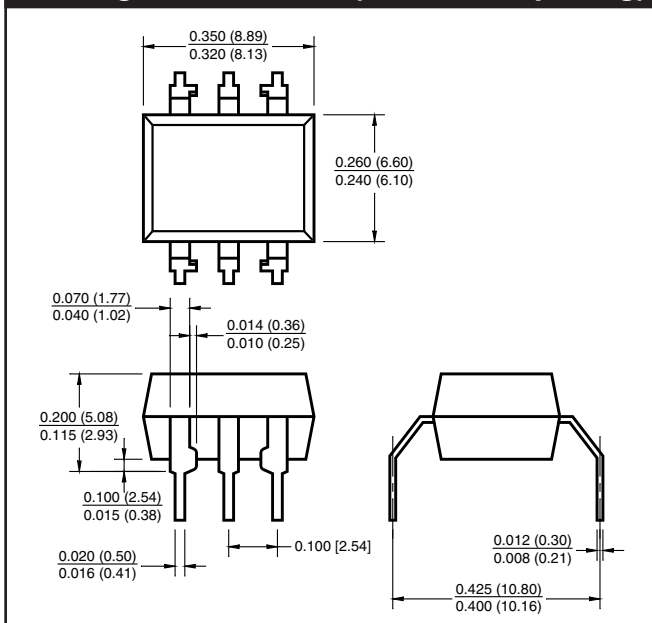

**Recommended Pad Layout for
Surface Mount Leadform**

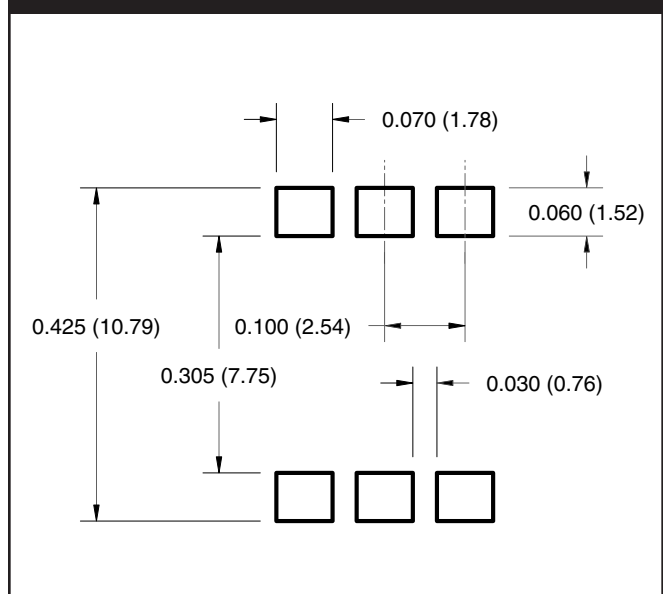

NOTE

All dimensions are in inches (millimeters)

MOC3081M

MOC3082M

MOC3083M

ORDERING INFORMATION

Order Entry Identifier	Description
S	Surface Mount Lead Bend
SR2	Surface Mount; Tape and reel
T	0.4" Lead Spacing
V	VDE 0884
TV	VDE 0884, 0.4" Lead Spacing
SV	VDE 0884, Surface Mount
SR2V	VDE 0884, Surface Mount, Tape & Reel

MARKING INFORMATION

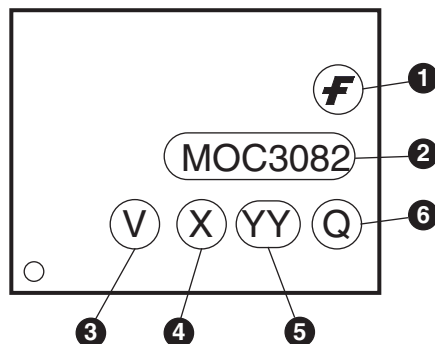

Definitions	
1	Fairchild logo
2	Device number
3	VDE mark (Note: Only appears on parts ordered with VDE option – See order entry table)
4	One digit year code, e.g., '3'
5	Two digit work week ranging from '01' to '53'
6	Assembly package code

*Note – Parts that do not have the 'V' option (see definition 3 above) that are marked with date code '325' or earlier are marked in portrait format.

MOC3081M

MOC3082M

MOC3083M

Carrier Tape Specifications

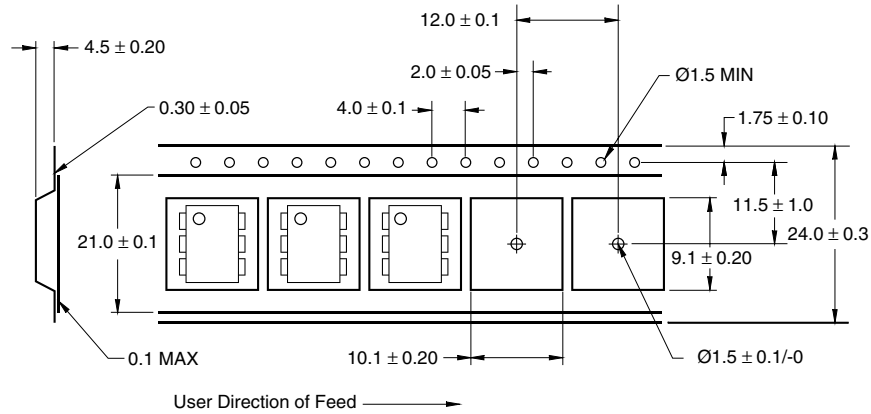

NOTE

All dimensions are in inches (millimeters)

Reflow Profile

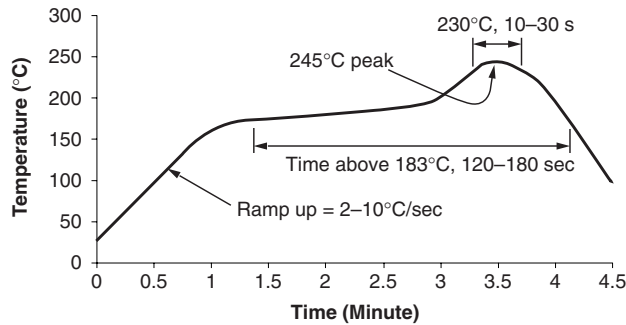

- Peak reflow temperature: 245°C (package surface temperature)
- Time of temperature higher than 183°C for $120-180\text{ seconds}$
- One time soldering reflow is recommended



6-PIN DIP ZERO-CROSS OPTOISOLATORS TRIAC DRIVER OUTPUT (800 VOLT PEAK)

MOC3081M

MOC3082M

MOC3083M

DISCLAIMER

FAIRCHILD SEMICONDUCTOR RESERVES THE RIGHT TO MAKE CHANGES WITHOUT FURTHER NOTICE TO ANY PRODUCTS HEREIN TO IMPROVE RELIABILITY, FUNCTION OR DESIGN. FAIRCHILD DOES NOT ASSUME ANY LIABILITY ARISING OUT OF THE APPLICATION OR USE OF ANY PRODUCT OR CIRCUIT DESCRIBED HEREIN; NEITHER DOES IT CONVEY ANY LICENSE UNDER ITS PATENT RIGHTS, NOR THE RIGHTS OF OTHERS.

LIFE SUPPORT POLICY

FAIRCHILD'S PRODUCTS ARE NOT AUTHORIZED FOR USE AS CRITICAL COMPONENTS IN LIFE SUPPORT DEVICES OR SYSTEMS WITHOUT THE EXPRESS WRITTEN APPROVAL OF THE PRESIDENT OF FAIRCHILD SEMICONDUCTOR CORPORATION. As used herein:

1. Life support devices or systems are devices or systems which, (a) are intended for surgical implant into the body, or (b) support or sustain life, and (c) whose failure to perform when properly used in accordance with instructions for use provided in the labeling, can be reasonably expected to result in a significant injury of the user.
2. A critical component in any component of a life support device or system whose failure to perform can be reasonably expected to cause the failure of the life support device or system, or to affect its safety or effectiveness.