

TOSHIBA POWER MODULE

MP7002

1. MAXIMUM RATINGS (Ta = 25°C)

DIODE

CHARACTERISTIC	SYMBOL	RATING	UNIT
Repetitive Peak Reverse Voltage	VRRM	600	V
Peak One Cycle Surge Forward Current (D1, D2, D3, D4) (50 Hz, Non-Repetitive)	IFSM	220	A
Forward Current	IF	25	A
Junction Temperature	Tj	150	°C
Storage Temperature Range	Tstg	-40~125	°C

IGBT

CHARACTERISTIC	SYMBOL	RATING	UNIT
Collector-Emitter Voltage	VCES	600	V
Gate-Emitter Voltage	VGES	±20	V
Collector Current	DC IC	40	A
	1 ms ICP	80	A
Collector Power Dissipation (Tc = 25°C)	PC	37	W
Junction Temperature	Tj	150	°C
Storage Temperature Range	Tstg	-40~125	°C

ALL SYSTEM

CHARACTERISTIC	SYMBOL	CONDITION	RATING	UNIT
Isolation Voltage	VISO	AC 1 minute	2500	V

000707EAA1

- TOSHIBA is continually working to improve the quality and reliability of its products. Nevertheless, semiconductor devices in general can malfunction or fail due to their inherent electrical sensitivity and vulnerability to physical stress. It is the responsibility of the buyer, when utilizing TOSHIBA products, to comply with the standards of safety in making a safe design for the entire system, and to avoid situations in which a malfunction or failure of such TOSHIBA products could cause loss of human life, bodily injury or damage to property. In developing your designs, please ensure that TOSHIBA products are used within specified operating ranges as set forth in the most recent TOSHIBA products specifications. Also, please keep in mind the precautions and conditions set forth in the "Handling Guide for Semiconductor Devices," or "TOSHIBA Semiconductor Reliability Handbook" etc..
- The TOSHIBA products listed in this document are intended for usage in general electronics applications (computer, personal equipment, office equipment, measuring equipment, industrial robotics, domestic appliances, etc.). These TOSHIBA products are neither intended nor warranted for usage in equipment that requires extraordinarily high quality and/or reliability or a malfunction or failure of which may cause loss of human life or bodily injury ("Unintended Usage"). Unintended Usage include atomic energy control instruments, airplane or spaceship instruments, transportation instruments, traffic signal instruments, combustion control instruments, medical instruments, all types of safety devices, etc.. Unintended Usage of TOSHIBA products listed in this document shall be made at the customer's own risk.
- The information contained herein is presented only as a guide for the applications of our products. No responsibility is assumed by TOSHIBA CORPORATION for any infringements of intellectual property or other rights of the third parties which may result from its use. No license is granted by implication or otherwise under any intellectual property or other rights of TOSHIBA CORPORATION or others.
- The information contained herein is subject to change without notice.



2. ELECTRICAL CHARACTERISTICS (Ta = 25°C)

DIODE

CHARACTERISTIC	SYMBOL	TEST CONDITION	MIN.	TYP.	MAX.	UNIT
Peak Forward Voltage (1)	V _{FM} (1)	I _F = 12.5 A	—	1.0	1.2	V
Peak Forward Voltage (2)	V _{FM} (2)	I _F = 30 A	—	1.20	1.55	V
Repetitive Peak Reverse Current	I _{RRM}	V _{RRM} = 600 V			10	μA
Peak Reverse Current (D1, D2, D3, D4)	I _{rr}	I _F = 30 A			100	A
Thermal Resistance	R _{th(j-c)}		—	—	3.5	°C/W

IGBT

CHARACTERISTIC	SYMBOL	TEST CONDITION	MIN.	TYP.	MAX.	UNIT
Gate Leakage Current	I _{GES}	V _{GE} = ±20 V, V _{CE} = 0	—	—	±500	nA
Collector Cut-off Current	I _{CES}	V _{CE} = 600 V, V _{GE} = 0	—	—	1.0	mA
Gate-Emitter Cut-off Voltage	V _{GE(OFF)}	I _C = 40 mA, V _{CE} = 5 V	3.0	—	6.0	V
Collector-Emitter Saturation Voltage	V _{CE(sat)}	I _C = 40 A, V _{GE} = 15 V	—	1.9	2.7	V
Input Capacitance	C _{ies}	V _{CE} = 10 V, V _{GE} = 0, f = 1 MHz	—	2900	—	pF
Switching Time	Rise Time	Load Resistance V _{CC} = 300 V, I _C = 40 A V _{GE} = ±15 V, (R _G = 56 Ω) (Note 1)	—	0.4	—	μs
	Turn-on Time		—	0.7	—	
	Fall Time		—	0.3	0.42	
	Turn-off Time		—	0.7	—	
Thermal Resistance	R _{th(j-c)}		—	—	3.3	°C/W

3. Mechanical Rating

CHARACTERISTIC	MIN.	TYP.	MAX.	UNIT
Fastening Torque	—	—	1.5	Nm

(Note 1) Switching Time Test Circuit & Timing Chart

Load Resistance Test Circuit

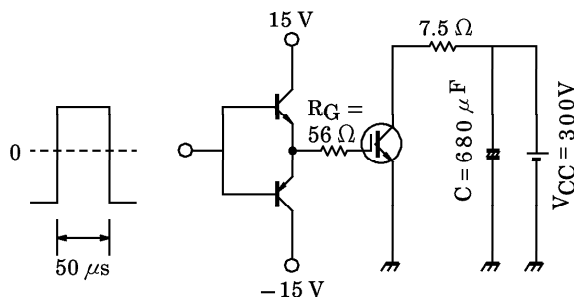

Waveform

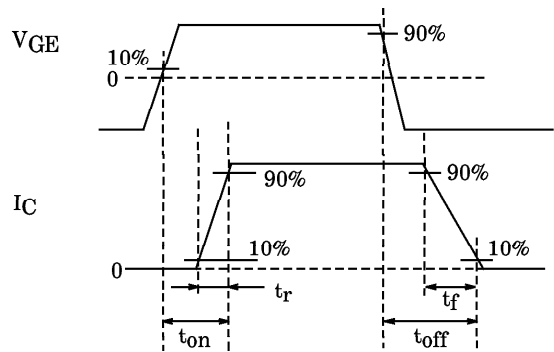

4. Package Dimension

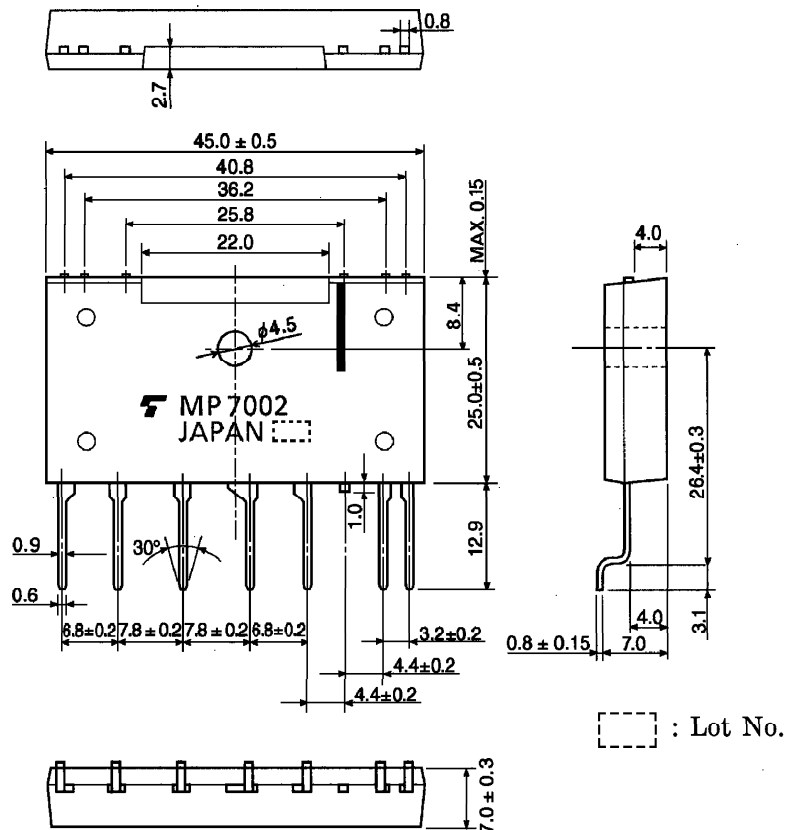

5. Image of Chips Mounting

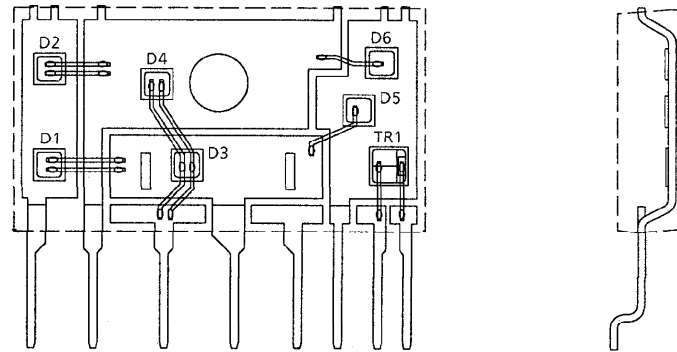

6. PSC Equivalent Circuit Diagram (including application circuit)

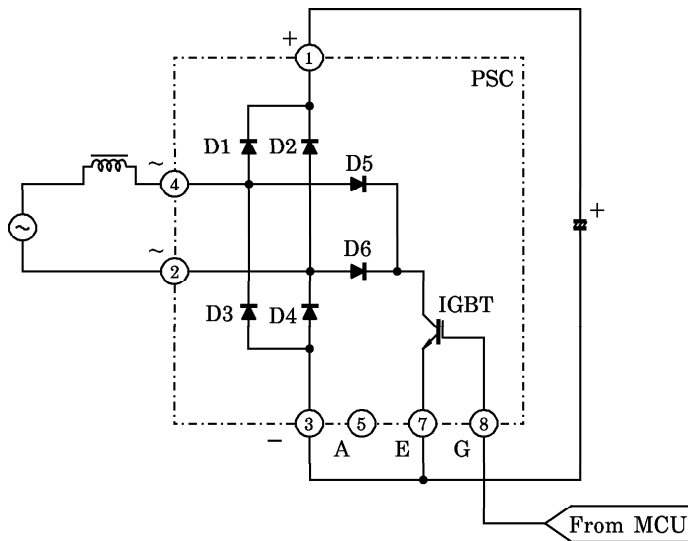

7. Pin Assignment

