

MP7613



Octal 12-Bit DAC Array™ D/A Converter with Output Amplifier and Parallel Data/Address μ P Control Logic

FEATURES

- Eight Independent Channel 12-Bit DACs with Output Amplifiers
- Low Power 320 mW (typ.)
- Parallel Digital Data and Address Port
- Double Buffered Data Interface
- Readback of DAC Latches
- Zero Volt Output Preset (Data = 10 .. 00)
- 12-Bit Resolution, 11-Bit Accuracy
- Extremely Well Matched DACs
- Extremely Low Analog Ground Current (<60 μ A/Channel)

- ± 10 V Output Swing with ± 11.4 V Supplies
- Rugged Construction – Latch-Up Proof
- Serial Version: MP7612

APPLICATIONS

- Data Acquisition Systems
- ATE
- Process Control
- Self-Diagnostic Systems
- Logic Analyzers
- Digital Storage Scopes
- PC Based Controller/DAS

GENERAL DESCRIPTION

The MP7613 provides eight independent 12-bit resolution Digital-to-Analog Converters with voltage output amplifiers and a parallel digital address and data port.

Built on using an advanced linear BiCMOS, these devices offer rugged solutions that are latch-up free, and take advantage of EXAR's patented thin-film resistor process which exhibits excellent long term stability and reliability.

A standard μ -processor and TTL/CMOS compatible 12-bit input

put data port loads the data into the pre-selected DACs.

This device can easily be interfaced to a data bus, and digital readback of each channel is available.

Typical DAC matching is 0.7 LSB across all codes. Accuracy of ± 0.75 LSB for DNL and ± 1 LSB for INL is achieved for B grade versions. The output amplifier is capable of sinking and sourcing 5mA, and the output voltage settles to 12-bits in less than 30 μ s (typ.).

SIMPLIFIED BLOCK DIAGRAM

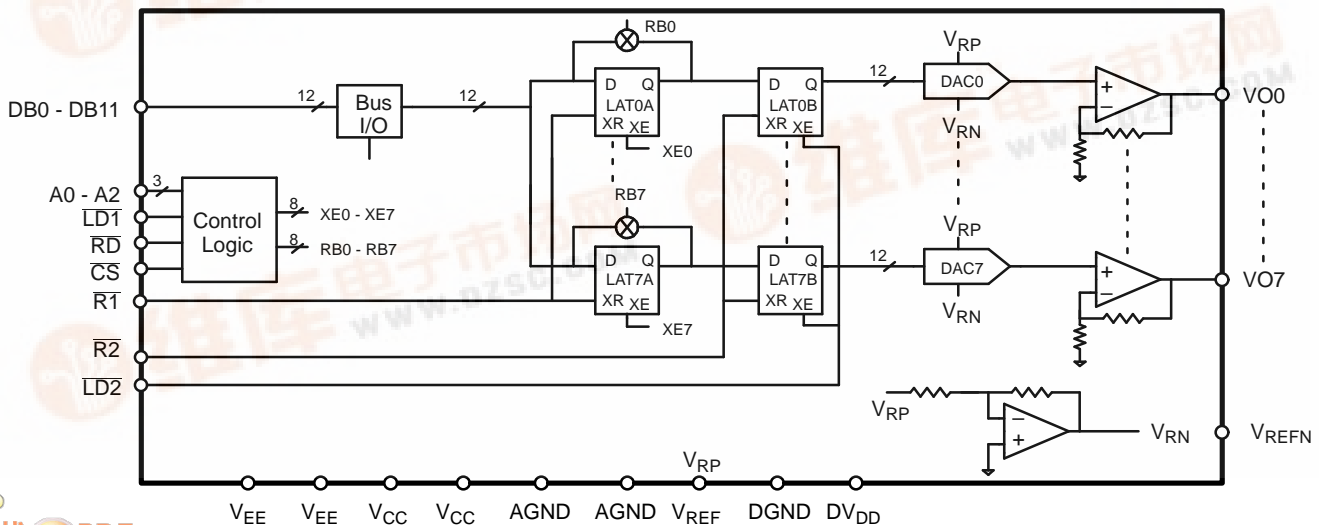

ORDERING INFORMATION

Package Type	Temperature Range	Part No.	Res. (Bits)	INL (LSB)	DNL (LSB)	FSE (LSB)
PQFP	-40 to +85°C	MP7613BE	12	±1	±0.75	±6
PQFP	-40 to +85°C	MP7613AE	12	±2	±1	±8
PGA	-40 to +85°C	MP7613BG	12	±1	±0.75	±6
PGA	-40 to +85°C	MP7613AG	12	±2	±1	±8
PLCC	-40 to +85°C	MP7613BP	12	±1	±0.75	±6
PLCC	-40 to +85°C	MP7613AP	12	±2	±1	±8

PIN CONFIGURATIONS *See Packaging Section for Package Dimensions*

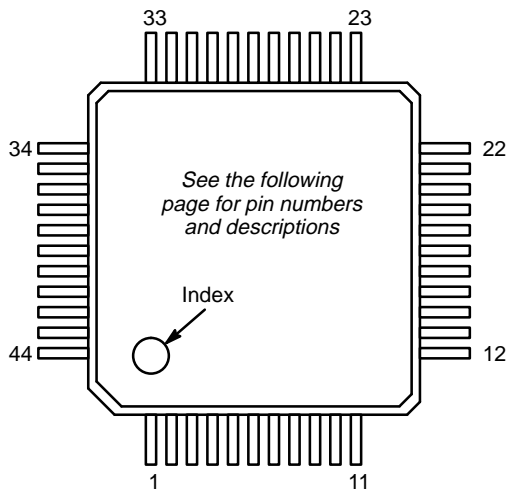

44-Pin PQFP (14 mm x 14 mm)
Q44

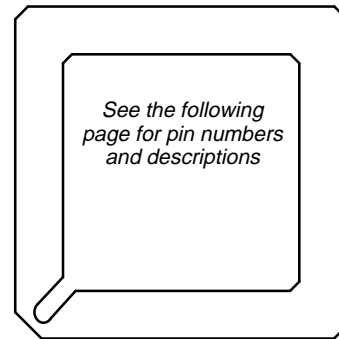

44-Pin PGA
G44

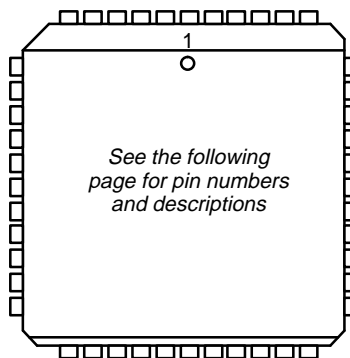

44-Pin PLCC
P44

PIN OUT DEFINITIONS

PLCC PIN NO.	PQFP & PGA PIN NO.	NAME	DESCRIPTION
29	1	N/C	No Connection
30	2	VO3	DAC 3 Output
31	3	V _{EE}	Analog Negative Power Supply (-12 V)
32	4	V _{CC}	Analog Positive Power Supply (+12 V)
33	5	DGND	Digital Ground (0 V)
34	6	V _{REF}	Analog Positive Voltage Reference Input (+5 V)
35	7	V _{REFN}	Analog Negative Voltage Reference Output (-2.5 V)
36	8	V _{CC}	Analog Positive Power Supply (+12 V)
37	9	V _{EE}	Analog Negative Power Supply (-12 V)
38	10	VO4	DAC 4 Output
39	11	N/C	No Connection
40	12	VO5	DAC 5 Output
41	13	VO6	DAC 6 Output
42	14	VO7	DAC 7 Output
43	15	AGND	Analog Ground (0 V)
44	16	\overline{CS}	Chip Select Enable
1	17	\overline{RD}	Read Back Enable
2	18	$\overline{R2}$	Second-Latch-Bank Reset Enable
3	19	$\overline{R1}$	First-Latch-Bank Reset Enable
4	20	$\overline{LD2}$	Second-Latch-Bank Load Enable
5	21	$\overline{LD1}$	First-Latch-Bank Load Enable
6	22	A2	Digital Address Bit 2
7	23	A1	Digital Address Bit 1
8	24	A0	Digital Address Bit 0
9	25	N/C	No Connection
10	26	N/C	No Connection
11	27	DB0	Digital Input Data Bit 0 (LSB)
12	28	DB1	Digital Input Data Bit 1
13	29	DB2	Digital Input Data Bit 2
14	30	DB3	Digital Input Data Bit 3
15	31	DB4	Digital Input Data Bit 4
16	32	DB5	Digital Input Data Bit 5
17	33	DB6	Digital Input Data Bit 6
18	34	DB7	Digital Input Data Bit 7
19	35	DB8	Digital Input Data Bit 8
20	36	DB9	Digital Input Data Bit 9
21	37	DB10	Digital Input Data Bit 10
22	38	DB11	Digital Input Data Bit 11 (MSB)
23	39	DV _{DD}	Digital Positive Power Supply (+5 V)
24	40	DGND	Digital Ground (0 V)
25	41	AGND	Analog Ground (0 V)
26	42	VO0	DAC 0 Output
27	43	VO1	DAC 1 Output
28	44	VO2	DAC 2 Output

ELECTRICAL CHARACTERISTICS

$V_{CC} = +12\text{ V}$, $V_{EE} = -12\text{ V}$, $V_{REF} = 5\text{ V}$, $DV_{DD} = 5.0\text{ V}$, $T = 25^\circ\text{C}$, Output Load = $5\text{ k}\Omega$ (unless otherwise noted)

Parameter	Symbol	25°C			Tmin to Tmax		Units	Test Conditions/Comments
		Min	Typ	Max	Min	Max		
STATIC PERFORMANCE								
Resolution (All Grades)	N	12					Bits	End Point Linearity Spec
Integral Non-Linearity (Relative Accuracy)	INL						LSB	
A				± 2		± 2		
B				± 1		± 1		
Differential Non-Linearity	DNL						LSB	
A				± 1		± 1		
B				± 0.75		± 0.75		
Positive Full Scale Error	+FSE						LSB	
A		6		± 8		± 8		
B		4		± 6		± 6		
Negative Full Scale Error	-FSE						LSB	
A		6		± 8		± 8		
B		4		± 6		± 6		
Bipolar Zero Offset	ZOFS						LSB	
A				± 4		± 4		
B				± 3		± 3		
INL Matching	Δ INL						LSB	
A				± 2		± 2		
B				± 1.5		± 1.5		
All Channels Maximum Error with DAC 0 adjusted to minimum error	ME						LSB	
A				± 4		± 4		
B				± 2		± 2		
Bipolar Zero Matching	Δ ZUFS						LSB	
A				± 4		± 4		
B				± 3		± 3		
Full Scale Error Matching	Δ FSE						LSB	
A				± 4		± 4		
B				± 3		± 3		
DYNAMIC PERFORMANCE								
Voltage Settling from $\overline{\text{LD}}$ to VDAC Out ¹	t_{sd}		30	50		50	μs	ZS to FS (20 V Step)
Channel-to-Channel Crosstalk ^{1, 6}	CT		0.04				LSB	DC
Digital Feedthrough ^{1, 6}	Q		-70				dB	CLK and Data to V_{OUTi}
Power Supply Rejection Ratio	PSRR			5			ppm/%	ΔV_{EE} & $\Delta V_{CC} = \pm 5\%$, ppm of FS
REFERENCE INPUTS								
Impedance of V_{REF}	REF	350	700	1.05k	350	1.05k	Ω	See Application Hints for driving the reference input
V_{REF} Voltage ^{1, 2}	V_{REF}	3.5		6			V	

ELECTRICAL CHARACTERISTICS (CONT'D)

Parameter	Symbol	25°C			Tmin to Tmax		Units	Test Conditions/Comments
		Min	Typ	Max	Min	Max		
DIGITAL INPUTS³								
Logic High	V_{IH}	2.4					V	
Logic Low	V_{IL}			0.8			V	
Input Current	I_L			± 10			μA	
Input Capacitance ¹	C_L			8			pF	
ANALOG OUTPUTS								
Output Swing		$-V_{EE} + 1.4$	$V_{CC} - 1.4$				V	
Output Drive Current		-5		5			mA	
V_{REFN} Output Drive Current		-10		+10			μA	For test purposes only
Output Impedance	R_O		1				Ω	
Output Short Circuit Current	I_{SC}		25				mA	+FS to AGND
			30				mA	+FS to V_{EE}
			40				mA	-FS to AGND
			55				mA	-FS to V_{CC}
DIGITAL OUTPUTS								
Output High Voltage	V_{OH}		4.5				V	
Output Low Voltage	V_{OL}		0.5				V	
POWER SUPPLIES								
V_{CC} Voltage ⁵	V_{CC}	$V_{REF} + 1.5$	12	12.75	$V_{REF} + 1.5$	12.75	V	
V_{EE} Voltage ⁵	V_{EE}	-12.75	-12	-5	-12.75	-5	V	
DV_{DD} Voltage	DV_{DD}	4.5	5	5.5	4.5	5.5	V	
Positive Supply Current	I_{CC}		8	10		10	mA	Bipolar zero
Negative Supply Current	I_{EE}		15	20		20	mA	Bipolar zero
Digital Supply Current	I_{DD}			2		2	mA	Bipolar zero
Power Dissipation	PD_{ISS}		320	420		450	mW	Bipolar zero
ANALOG GROUND CURRENT								
Per Channel ¹	I_{AGND}		± 60				μA	See Application Notes
DIGITAL TIMING SPECIFICATIONS^{1,4}								
Data Setup Time	t_{DS}		20				ns	$V_{IL} = 0 V, V_{IH} = 5 V, C_L = 20 pF$
Data Hold Time	t_{DH}		20				ns	
Address Set-up Time	t_{AS}		100				ns	
Address Hold Time	t_{AH}		0				ns	
Chip Select to $\overline{LD1}$ Set-up Time	t_{CS1}		6				ns	
Chip Select to $\overline{LD1}$ Hold Time	t_{CH1}		0				ns	
$\overline{LD1}$ Pulse Width	t_{LD1W}		50				ns	
$\overline{LD1}$ Negative Edge to $\overline{LD2}$ Positive Edge	t_{LD1LD2}		60				ns	
$\overline{LD2}$ Pulse Width	t_{LD2W}		60				ns	
Chip Select to \overline{RD} Set-Up Time	t_{CS2}		6				ns	
Chip Select to \overline{RD} Hold Time	t_{CH2}		0				ns	
\overline{RD} Pulse Width	t_{RD}		600				ns	
High Z to Data Valid for Readback	t_{DA}		600				ns	
Data Valid for Readback to High Z	t_{DR}		200				ns	
$\overline{R1}$ Pulse Width	$R1W$		100				ns	
$\overline{R2}$ Pulse Width	$R2W$		100				ns	

Specifications are subject to change without notice

ELECTRICAL CHARACTERISTICS (CONT'D)

NOTES:

- 1 Guaranteed; not tested.
- 2 Specified values guarantee functionality.
- 3 Digital inputs should not go below digital GND or exceed DV_{DD} supply voltage.
- 4 See Figures 1, 2, and 3. All digital input signals are specified with t_R = t_F = 10 ns 10% to 90% and timed from a 50% voltage level.
- 5 For power supply values $\pm 2 \cdot V_{REF}$, the output swing is limited as specified in Analog Outputs.
- 6 Digital feedthrough and channel-to-channel crosstalk are heavily dependent on the board layout and environment.

Specifications are subject to change without notice

ABSOLUTE MAXIMUM RATINGS (TA = +25°C unless otherwise noted)^{1, 2}

V _{CC} to AGND	+16.5 V	Digital Input & Digital Output Voltage to:	
V _{EE} to AGND	-16.5 V	DV _{DD}	+5 V
DV _{DD} to DGND	+6.5 V	DGND	-5 V
V _{REF} to DGND	+7.0 V	Operating Temperature Range	-40°C to +85°C
Analog Outputs & Inputs		Maximum Junction Temperature	150°C
Infinite Shorts to V _{CC} , V _{EE} , DV _{DD} , AGND and DGND		Storage Temperature Range	-65°C to +150°C
(provided that power dissipation of the package spec is not exceeded)		Lead Temperature (Soldering, 10 sec)	+300°C
AGND to DGND	± 1 V	Package Power Dissipation Rating to 75°C	
(Functionality guaranteed for ± 0.5 V only)		PQFP, PGA, PLCC	800mW
		Derates above 75°C	11mW/°C

NOTES:

- 1 Stresses above those listed under "Absolute Maximum Ratings" may cause permanent damage to the device. This is a stress rating only and functional operation at or above this specification is not implied. Exposure to maximum rating conditions for extended periods may affect device reliability.
- 2 Any input pin which can see a value outside the absolute maximum ratings should be protected by Schottky diode clamps (HP5082-2835) from input pin to the supplies. All inputs have protection diodes which will protect the device from short transients outside the supplies of less than 100mA for less than 100 μ s.

APPLICATION NOTES

Refer to Section 8 for Applications Information

NOTE: When using these DACs to drive remote devices, the accuracy of the output can be improved by utilizing a remote analog ground connection. The difference between the DGND and AGND should be limited to ± 300 mV to assure normal operation. If there is any chance that the AGND to DGND can be greater than ± 1 V, we recommend two back-to-back diodes be used between DGND and AGND to clamp the voltage and prevent damage to the DAC. Using a buffer between the remote ground location and AGND may help reduce noise induced from long lead or trace lengths.

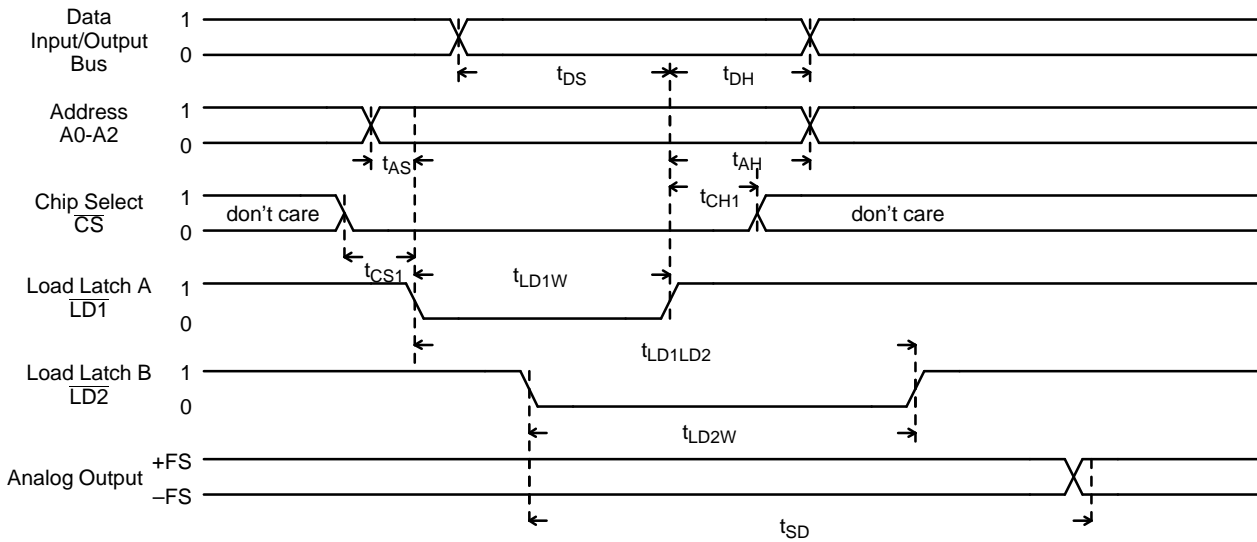

Figure 1. Loading Latch A and Updating Latch B

Notes

- (1) Chip Select (\overline{CS}) and Load LATCHA ($\overline{LD1}$) Signals follow the same timing constraints and are interchangeable in the above diagram.
- (2) $R1 = R2 = 1$.
- (3) For the case where $\overline{LD2}$ is in the low state, analog output would respond to the falling edge of $\overline{LD1}$ (transparent mode).

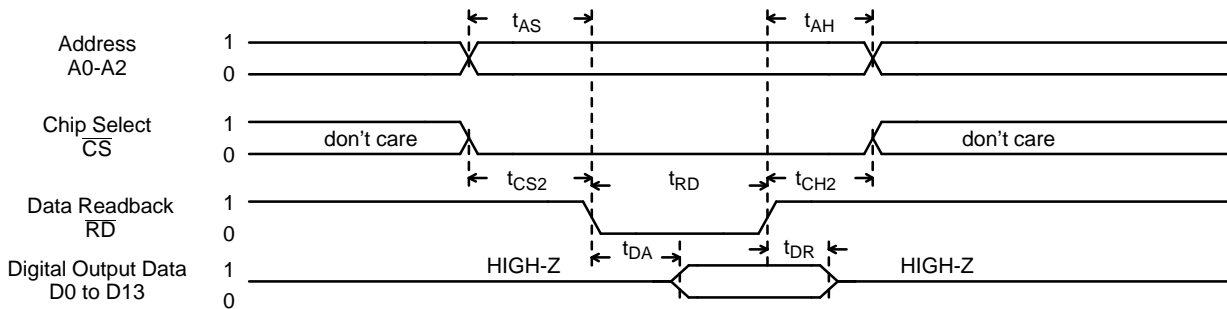

Figure 2. Read Back First Latch Bank of One DAC

Notes

- (1) Chip Select (\overline{CS}) and Data Readback (\overline{RD}) Signals follow the same timing constraints and are interchangeable in the above diagram.
- (2) $R1 = R2 = 1$.

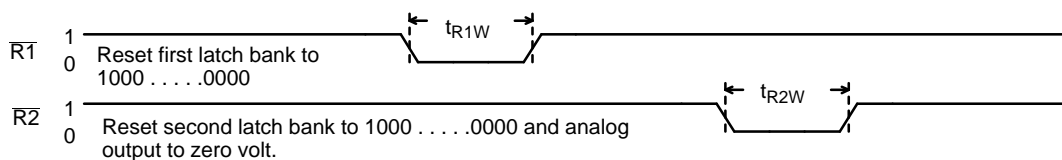

Figure 3. Reset Operations

A standard μ -processor and TTL/CMOS compatible input data port loads the data into the pre-selected DACs. If $\overline{CS} = 0$, the chip accesses digital data on the bus. Then address bits A0 to A2 select the appropriate DAC and $\overline{LD1}$ loads the data into the first-latch-bank. When all 8-channels first-latch-banks are loaded, then $\overline{LD2}$ enables the second-latch-bank and updates

all 8-channels simultaneously. The selected DAC becomes transparent (activity on the digital inputs appear at the analog output) when both $\overline{LD1} = \overline{LD2} = 0$.

$\overline{R1} = 0$ resets the first-latch-bank. $\overline{R2} = 0$ resets the second-latch-bank which sets the analog output to zero volts (data = 100...00), regardless of digital inputs.

Function	A2	A1	A0	\overline{RD}	$\overline{LD1}$	$\overline{LD2}$	\overline{CS}	$\overline{R1}$	$\overline{R2}$
Load Latch 1 of DAC1	0	0	0	1	0→1	1	0	1	1
Load Latch 1 of DAC2	0	0	1	1	0→1	1	0	1	1
Load Latch 1 of DAC3	0	1	0	1	0→1	1	0	1	1
Load Latch 1 of DAC4	0	1	1	1	0→1	1	0	1	1
Load Latch 1 of DAC5	1	0	0	1	0→1	1	0	1	1
Load Latch 1 of DAC6	1	0	1	1	0→1	1	0	1	1
Load Latch 1 of DAC7	1	1	0	1	0→1	1	0	1	1
Load Latch 1 of DAC8	1	1	1	1	0→1	1	0	1	1
Load Latch 2 of DAC1→8	X	X	X	1	1	0→1	0	1	1
Read Latch 1 of DAC1	0	0	0	0	1	1	0	1	1
Read Latch 1 of DAC2	0	0	1	0	1	1	0	1	1
Read Latch 1 of DAC3	0	1	0	0	1	1	0	1	1
Read Latch 1 of DAC4	0	1	1	0	1	1	0	1	1
Read Latch 1 of DAC5	1	0	0	0	1	1	0	1	1
Read Latch 1 of DAC6	1	0	1	0	1	1	0	1	1
Read Latch 1 of DAC7	1	1	0	0	1	1	0	1	1
Read Latch 1 of DAC8	1	1	1	0	1	1	0	1	1
Reset Latch 1 of DAC1→8	X	X	X	X	X	X	X	0	1
Reset Latch 2 of DAC1→8	X	X	X	X	X	X	X	1	0

Note: 1: High, 0: Low, X: Don't Care

Table 1. Octal Parallel Data Input 14-Bit DAC Truth Table

Note: For timing information see *Electrical Characteristics*

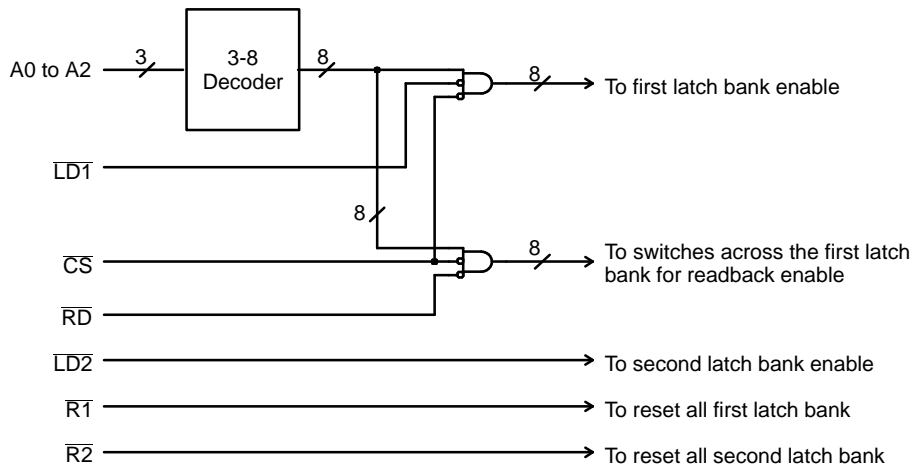

Figure 4. Simplified Parallel Logic Port

Hex Code	Binary Code	Output Voltage = $2 \cdot V_r \left(-1 + \frac{2 \cdot D}{4096}\right)$ ($V_r = +5\text{ V}$)
0 0 0	000000000000	$10 \cdot (-1 + 0) = -10$
⋮	⋮	⋮
7 F F	011111111111	$10 \cdot \left(-1 + \frac{4094}{4096}\right) = -4.88\text{ mV}$
8 0 0	100000000000	$10 \cdot \left(-1 + \frac{4096}{4096}\right) = 0$
8 0 1	100000000001	$10 \cdot \left(-1 + \frac{4098}{4096}\right) = 4.88\text{ mV}$
⋮	⋮	⋮
F F F	111111111111	$10 \cdot \left(-1 + \frac{8190}{4096}\right) = 9.99512$

**Table 2. MP7613
Ideal DAC Output vs. Input Code**

Note: See Electrical Characteristics on pages 28-30 for real system accuracy

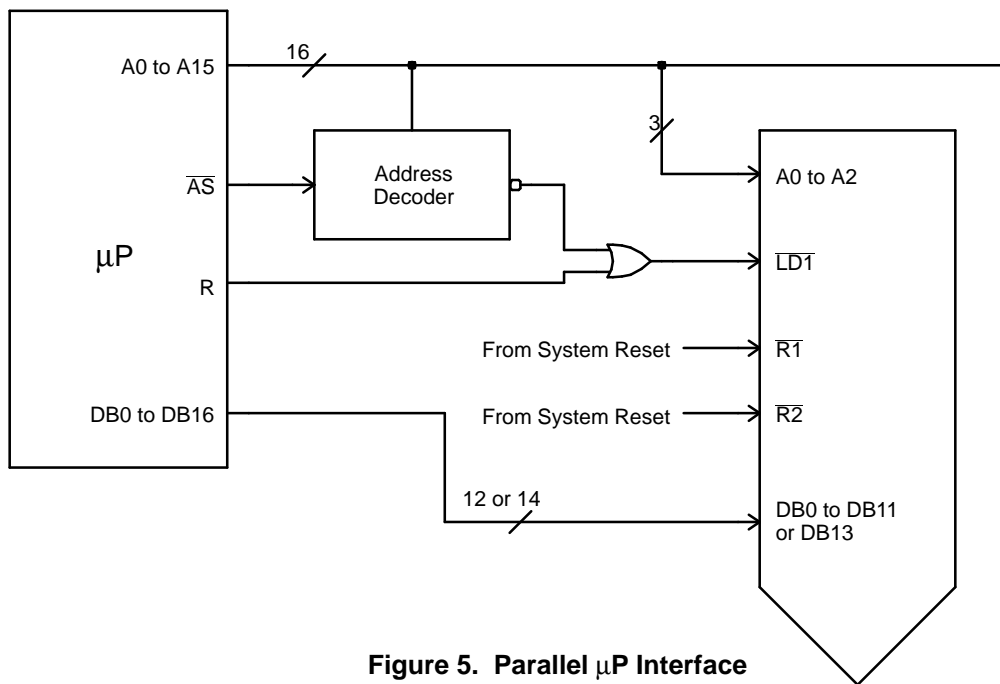

Figure 5. Parallel μP Interface

PERFORMANCE CHARACTERISTICS



Graph 1. Typical Output Settling Characteristic
 $V_{REF} = 5\text{ V}$, $R_L = 5\text{ K}$, $C_L = 500\text{ pF}$

Graph 1 shows the typical output settling characteristic of the MP7610 Family for a RESET → ZS → FS → ZS series of code transitions. The top graph shows the output voltage transients, while the bottom graph shows the difference between the output and the ideal output.

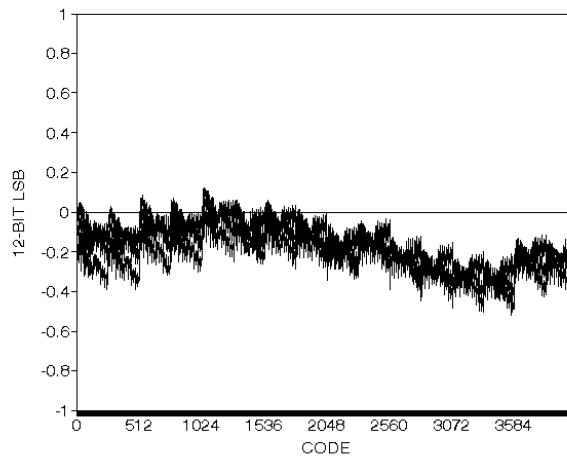

Graph 2. Linearity with
 $V_{REF} = 5\text{ V}$, All DACs, All Codes

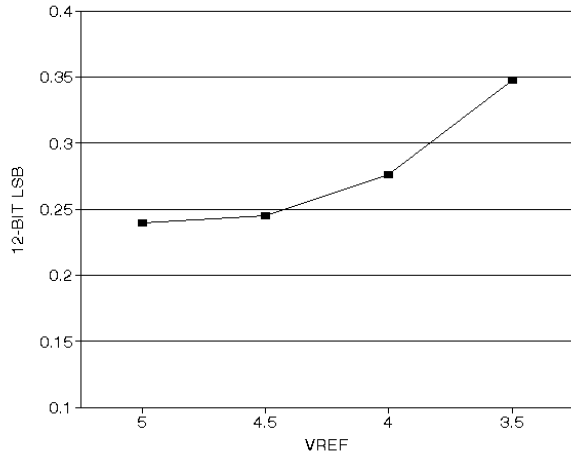

Graph 3. DAC 0 INL vs. VREF

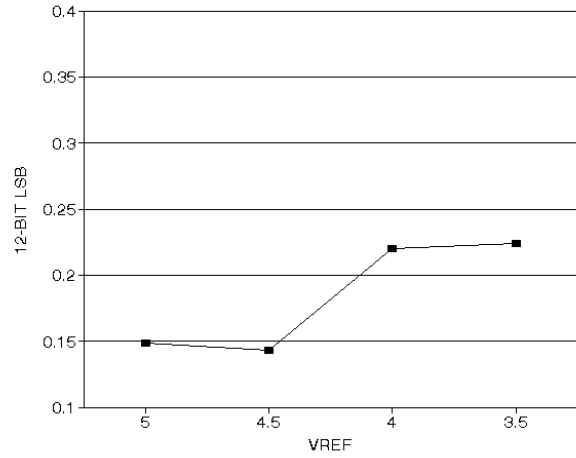

Graph 4. DAC 0 DNL vs. VREF

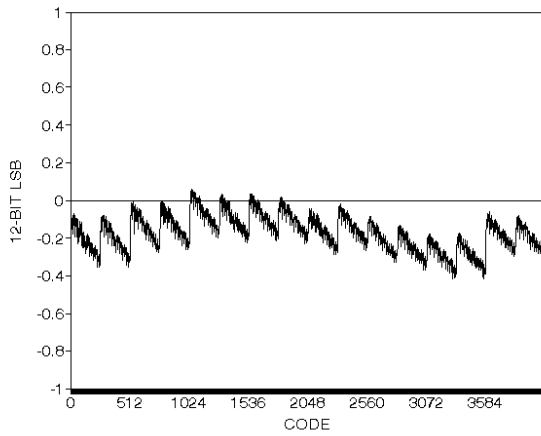

Graph 5. DAC 0 Linearity with VREF = 5 V, VOUT = ±10

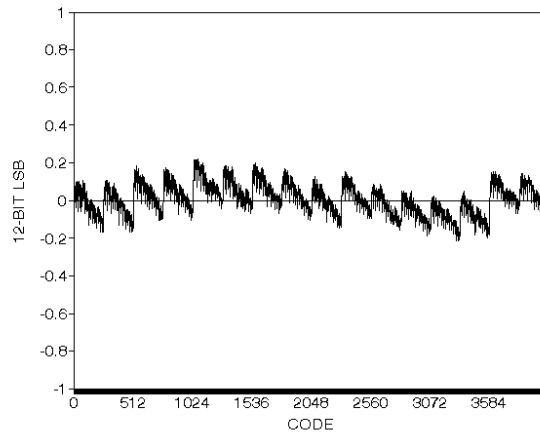

Graph 6. DAC 0 Linearity with VREF = 4.5 V, VOUT = ±9

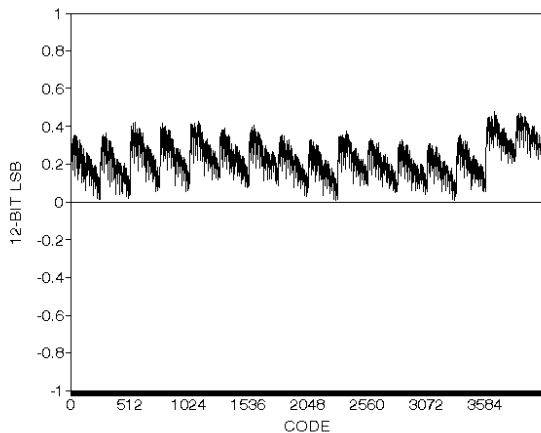

Graph 7. DAC 0 Linearity with VREF = 4 V, VOUT = ±8

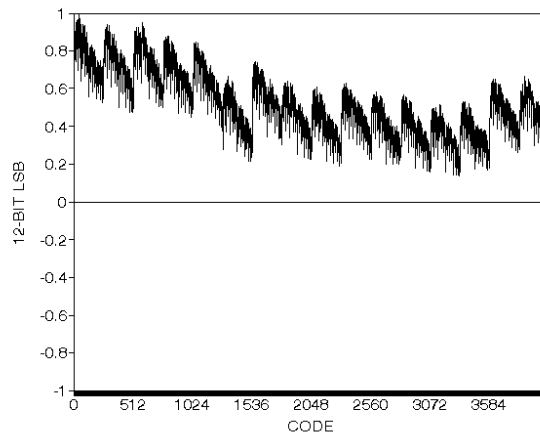

Graph 8. DAC 0 Linearity with VREF = 3.5 V, VOUT = ±7

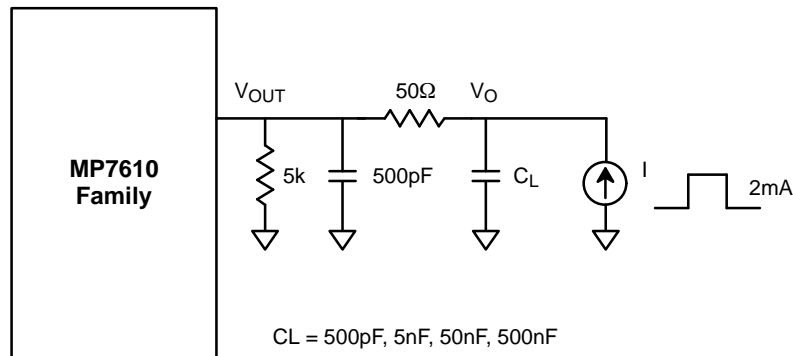
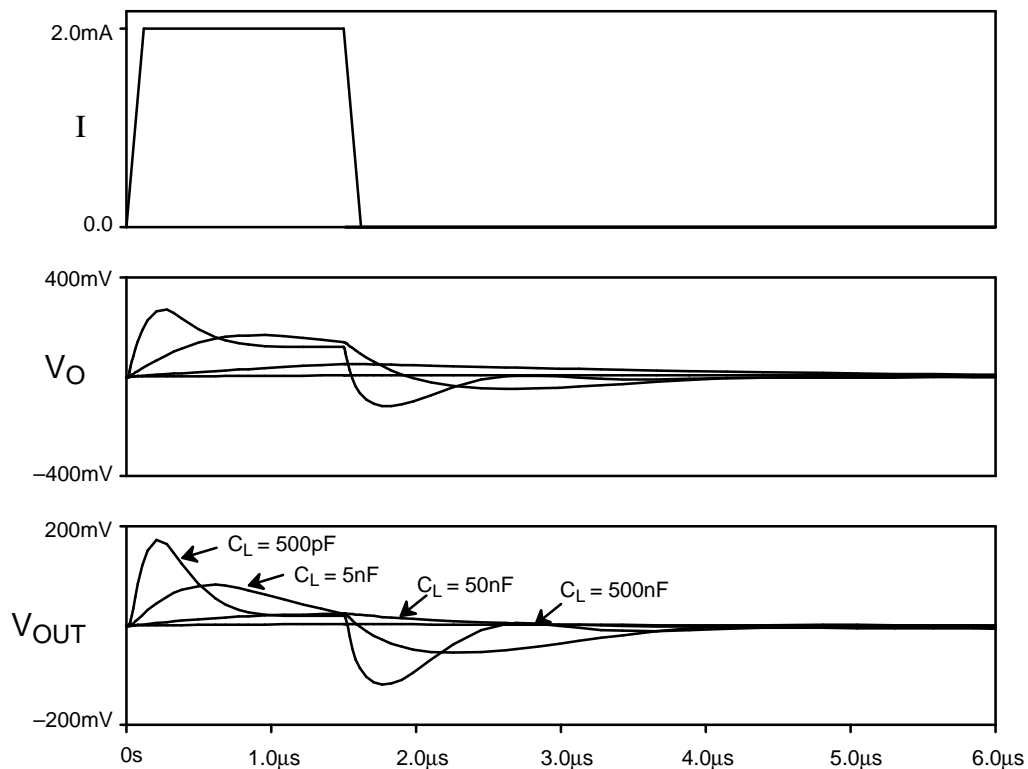
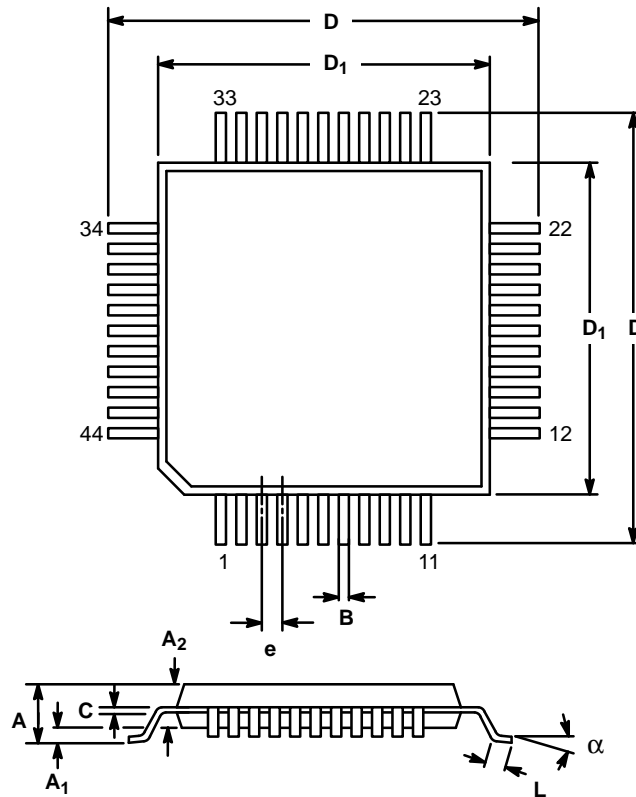

Figure 6. Circuit for Determining Typical Analog Output Pulse Response



Graph 9. Typical Response of the MP7610 Family Analog Output to a Current Pulse with $C_L=500\text{pF}$, 5nF , 50nF , 500nF
(See NO TAG above)

**44 LEAD PLASTIC QUAD FLAT PACK
(14mm x 14mm PQFP, METRIC)
Q44**



SYMBOL	MILLIMETERS		INCHES	
	MIN	MAX	MIN	MAX
A	—	3.15	—	0.124
A ₁	0.25	—	0.01	—
A ₂	2.6	2.8	0.102	0.110
B	0.3	0.4	0.012	0.016
C	0.13	0.23	0.005	0.009
D	16.95	17.45	0.667	0.687
D ₁	13.9	14.1	0.547	0.555
e	1.00 BSC		0.039 BSC	
L	0.65	1.03	0.026	0.040
α	0°	7°	0°	7°
Coplanarity = 4 mil max.				

44 LEAD PIN GRID ARRAY (PGA) G44

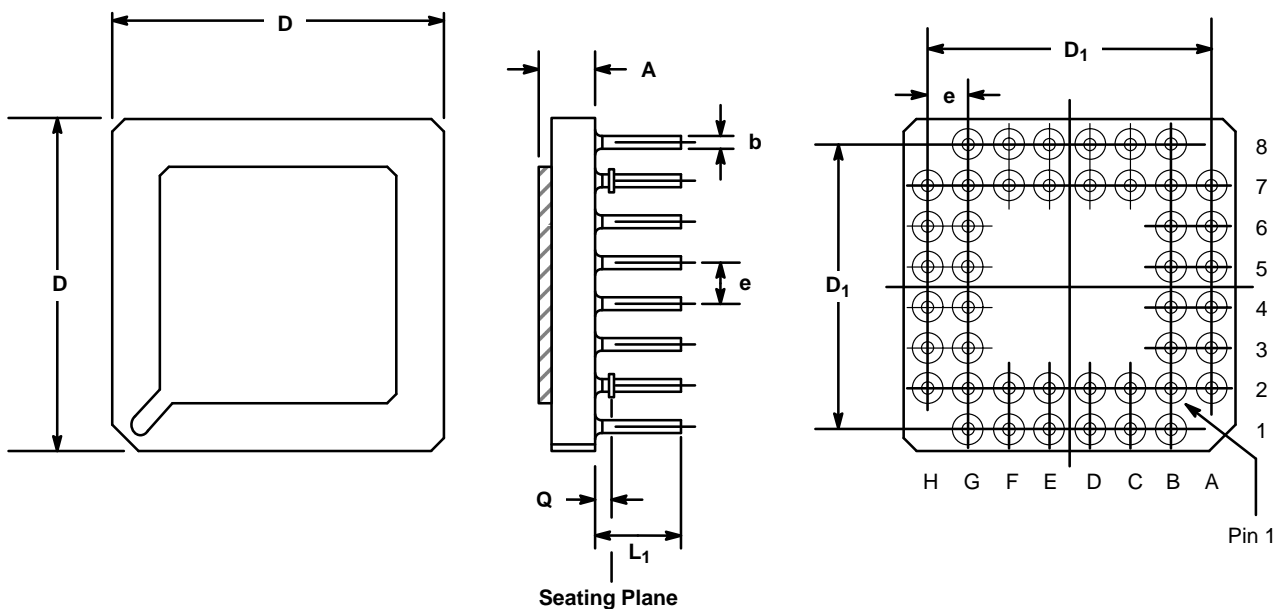

SYMBOL	INCHES		MILLIMETERS	
	MIN	MAX	MIN	MAX
A	0.082	0.10	2.08	2.54
b	0.016	0.020	0.406	0.508
D	0.841	0.859	21.4	21.8
D ₁	0.688	0.712	17.5	18.1
e	0.100 typ.		2.54 typ.	
L ₁	0.170	0.190	4.32	4.83
Q	0.050 typ.		1.27 typ.	

CONNECTION TABLE					
PAD	PIN	PAD	PIN	PAD	PIN
1	B2	16	G4	31	C8
2	B1	17	H4	32	C7
3	C2	18	H5	33	B8
4	C1	19	G5	34	B7
5	D2	20	H6	35	A7
6	D1	21	G6	36	B6
7	E1	22	H7	37	A6
8	E2	23	G7	38	B5
9	F1	24	G8	39	A5
10	F2	25	F7	40	A4
11	G1	26	F8	41	B4
12	G2	27	E7	42	A3
13	H2	28	E8	43	B3
14	G3	29	D8	44	A2
15	H3	30	D7		

Note: The letters A-H and numbers 1-8 are the coordinates of a grid. For example, pin 1 is at the intersections of the "B" vertical line and the "2" horizontal line.

**44 LEAD PLASTIC LEADED CHIP CARRIER
(PLCC)
P44**

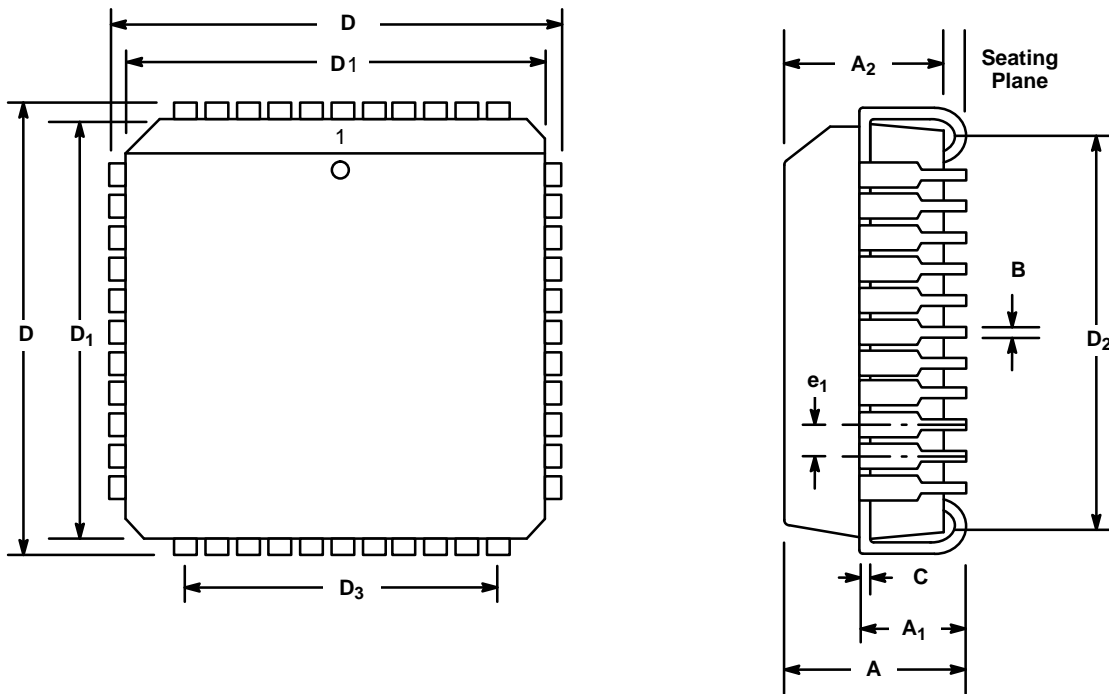

SYMBOL	INCHES		MILLIMETERS	
	MIN	MAX	MIN	MAX
A	0.165	0.180	4.19	4.57
A ₁	0.100	0.110	2.54	2.79
A ₂	0.148	0.156	3.76	3.96
B	0.013	0.021	0.330	0.553
C	0.097	0.0103	0.246	0.261
D	0.685	0.695	17.40	17.65
D ₁ (1)	0.650	0.654	16.51	16.61
D ₂	0.590	0.630	14.99	16.00
D ₃	0.500 Ref		12.70 Ref.	
e ₁	0.050 BSC		1.27 BSC	

Note: (1) Dimension D₁ does not include mold protrusion.
Allowed mold protrusion is 0.254 mm/0.010 in.

NOTICE

EXAR Corporation reserves the right to make changes to the products contained in this publication in order to improve design, performance or reliability. EXAR Corporation assumes no responsibility for the use of any circuits described herein, conveys no license under any patent or other right, and makes no representation that the circuits are free of patent infringement. Charts and schedules contains here in are only for illustration purposes and may vary depending upon a user's specific application. While the information in this publication has been carefully checked; no responsibility, however, is assumed for inaccuracies.

EXAR Corporation does not recommend the use of any of its products in life support applications where the failure or malfunction of the product can reasonably be expected to cause failure of the life support system or to significantly affect its safety or effectiveness. Products are not authorized for use in such applications unless EXAR Corporation receives, in writing, assurances to its satisfaction that: (a) the risk of injury or damage has been minimized; (b) the user assumes all such risks; (c) potential liability of EXAR Corporation is adequately protected under the circumstances.

Copyright 1993 EXAR Corporation

Datasheet April 1995

Reproduction, in part or whole, without the prior written consent of EXAR Corporation is prohibited.