



# Integrated Silicon Pressure Sensor Manifold Absolute Pressure Sensor On-Chip Signal Conditioned, Temperature Compensated and Calibrated

The Motorola MPX4101 series Manifold Absolute Pressure (MAP) sensor for engine control is designed to sense absolute air pressure within the intake manifold. This measurement can be used to compute the amount of fuel required for each cylinder. The small form factor and high reliability of on-chip integration makes the Motorola MAP sensor a logical and economical choice for automotive system designers.

### Features

- 1.7% Maximum Error Over 0° to 85°C
- Specifically Designed for Intake Manifold Absolute Pressure Sensing in Engine Control Systems
- Ideally Suited for Microprocessor Interfacing
- Patented Silicon Shear Stress Strain Gauge
- Temperature Compensated Over -40°C to +125°C
- Durable Epoxy Unibody Element
- Ideal for Non-Automotive Applications

### Application Examples

- Manifold Sensing for Automotive Systems

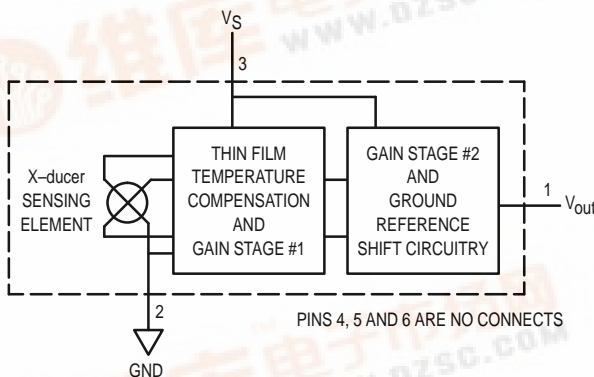
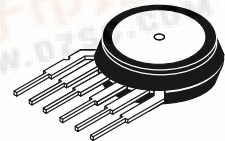

Figure 1. Fully Integrated Pressure Sensor Schematic

## MPX4101 SERIES

INTEGRATED  
 PRESSURE SENSOR  
 15 to 102 kPa  
 (2.18 to 14.8 psi)  
 0.25 to 4.95 V Output



BASIC CHIP CARRIER  
 ELEMENT  
 CASE 867-08, STYLE 1

### PIN NUMBER

|   |                  |   |     |
|---|------------------|---|-----|
| 1 | V <sub>out</sub> | 4 | N/C |
| 2 | Gnd              | 5 | N/C |
| 3 | V <sub>S</sub>   | 6 | N/C |

NOTE: Pins 4, 5, and 6 are internal device connections. Do not connect to external circuitry or ground. Pin 1 is noted by the notch in the Lead.

The MPX4101 series piezoresistive transducer is a state-of-the-art, monolithic, signal conditioned, silicon pressure sensor. This sensor, with its patented transducer, combines advanced micromachining techniques, thin film metallization, and bipolar semiconductor processing to provide an accurate, high level analog output signal that is proportional to applied pressure.

Figure 1 shows a block diagram of the internal circuitry integrated on a pressure sensor chip.

## MPX4101 SERIES

### MAXIMUM RATINGS(1)

| Parametric                  | Symbol      | Value       | Unit |
|-----------------------------|-------------|-------------|------|
| Overpressure(2) (P1 > P2)   | $P_{max}$   | 400         | kPa  |
| Burst Pressure(2) (P1 > P2) | $P_{burst}$ | 1000        | kPa  |
| Storage Temperature         | $T_{stg}$   | -40 to +125 | °C   |
| Operating Temperature       | $T_A$       | -40 to +125 | °C   |

- $T_C = 25^\circ\text{C}$  unless otherwise noted.
- Exposure beyond the specified limits may cause permanent damage or degradation to the device.

### OPERATING CHARACTERISTICS ( $V_S = 5.1\text{ Vdc}$ , $T_A = 25^\circ\text{C}$ unless otherwise noted, P1 > P2)

| Characteristic   | Symbol    | Min   | Typ       | Max        | Unit        |
|--|-----------|-------|-----------|------------|-------------|
| Pressure Range(1)  | POP       | 15    | —         | 102        | kPa         |
| Supply Voltage(1)  | $V_S$     | 4.85  | 5.1       | 5.35       | Vdc         |
| Supply Current   | $I_o$     | —     | 7.0       | 10         | mAdc        |
| Minimum Pressure Offset(3)<br>@ $V_S = 5.1\text{ Volts}$ | $V_{off}$ | 0.171 | 0.252     | 0.333      | Vdc         |
| Full Scale Output(4)<br>@ $V_S = 5.1\text{ Volts}$       | $V_{FSO}$ | 4.870 | 4.951     | 5.032      | Vdc         |
| Full Scale Span(5)<br>@ $V_S = 5.1\text{ Volts}$         | $V_{FSS}$ | —     | 4.7       | —          | Vdc         |
| Accuracy(6)  | —         | —     | —         | $\pm 1.72$ | % $V_{FSS}$ |
| Sensitivity  | V/P       | —     | 54        | —          | mV/kPa      |
| Response Time(7)   | $t_R$     | —     | 1.0       | —          | ms          |
| Output Source Current at Full Scale Output               | $I_{o+}$  | —     | 0.1       | —          | mAdc        |
| Warm-Up Time(8)  | —         | —     | 20        | —          | ms          |
| Offset Stability(9)                                      | —         | —     | $\pm 0.5$ | —          | % $V_{FSS}$ |

Decoupling circuit shown in Figure 3 required to meet electrical specifications.

### MECHANICAL CHARACTERISTICS

| Characteristic                   | Symbol | Min | Typ | Max | Unit  |
|----------------------------------|--------|-----|-----|-----|-------|
| Weight, Basic Element (Case 867) | —      | —   | 4.0 | —   | Grams |
| Common Mode Line Pressure(10)    | —      | —   | —   | 690 | kPa   |

#### NOTES:

- 1.0 kPa (kiloPascal) equals 0.145 psi.
- Device is ratiometric within this specified excitation range.
- Offset ( $V_{off}$ ) is defined as the output voltage at the minimum rated pressure.
- Full Scale Output ( $V_{FSO}$ ) is defined as the output voltage at the maximum or full rated pressure.
- Full Scale Span ( $V_{FSS}$ ) is defined as the algebraic difference between the output voltage at full rated pressure and the output voltage at the minimum rated pressure.
- Accuracy (error budget) consists of the following:
  - Linearity: Output deviation from a straight line relationship with pressure over the specified pressure range.
  - Temperature Hysteresis: Output deviation at any temperature within the operating temperature range, after the temperature is cycled to and from the minimum or maximum operating temperature points, with zero differential pressure applied.
  - Pressure Hysteresis: Output deviation at any pressure within the specified range, when this pressure is cycled to and from the minimum or maximum rated pressure, at  $25^\circ\text{C}$ .
  - TcSpan: Output deviation over the temperature range of 0 to  $85^\circ\text{C}$ , relative to  $25^\circ\text{C}$ .
  - TcOffset: Output deviation with minimum rated pressure applied, over the temperature range of 0 to  $85^\circ\text{C}$ , relative to  $25^\circ\text{C}$ .
  - Variation from Nominal: The variation from nominal values, for Offset or Full Scale Span, as a percent of  $V_{FSS}$ , at  $25^\circ\text{C}$ .
- Response Time is defined as the time for the incremental change in the output to go from 10% to 90% of its final value when subjected to a specified step change in pressure.
- Warm-up is defined as the time required for the product to meet the specified output voltage after the Pressure has been stabilized.
- Offset stability is the product's output deviation when subjected to 1000 hours of Pulsed Pressure, Temperature Cycling with Bias Test.
- Common mode pressures beyond specified may result in leakage at the case-to-lead interface.

## MPX4101 SERIES

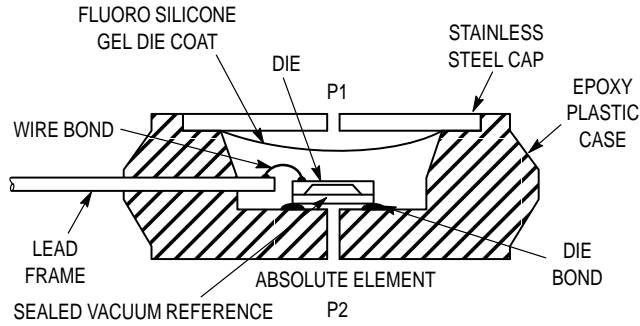

**Figure 2. Cross Sectional Diagram (Not to Scale)**

Figure 2 illustrates an absolute sensing chip in the basic chip carrier (Case 867). A fluorosilicone gel isolates the die surface and wire bonds from the environment, while allowing the pressure signal to be transmitted to the sensor diaphragm. The MPX4101A series pressure sensor operating characteristics, and internal reliability and qualification tests are based on use of dry air as the pressure media. Media, other than dry air, may have adverse effects on sensor performance and long-term reliability. Contact the factory for information regarding media compatibility in your application.

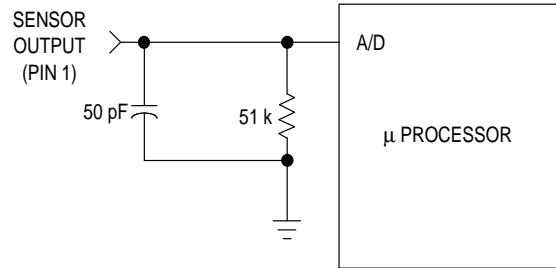

**Figure 3. Decoupling Filter for Sensor to Microprocessor Interface**

Figure 3 shows a typical decoupling circuit for interfacing the integrated MAP sensor to the A/D input of a microprocessor. Proper decoupling of the power supply is recommended.

Figure 4 shows the sensor output signal relative to pressure input. Typical, minimum, and maximum output curves are shown for operation over a temperature range of 0° to 85°C. (The output will saturate outside of the specified pressure range.)

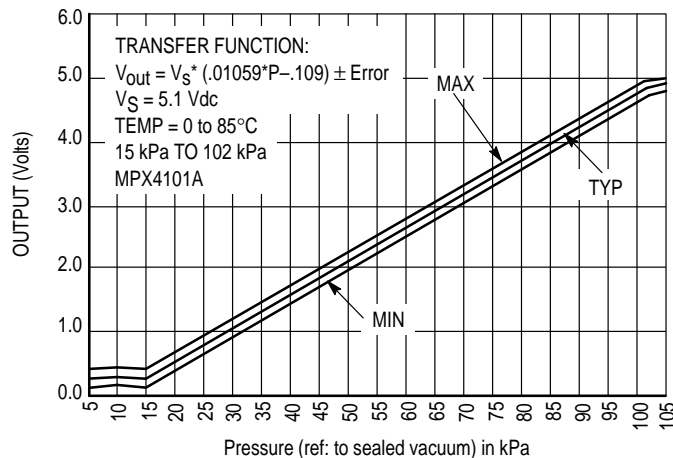

**Figure 4. Output versus Absolute Pressure**

# MPX4101 SERIES

## Transfer Function (MPX4101A)

**Nominal Transfer Value:**  $V_{out} = V_S (P \times 0.01059 - 0.10941)$   
 $\pm (\text{Pressure Error} \times \text{Temp. Factor} \times 0.01059 \times V_S)$   
 $V_S = 5.1 \text{ V} \pm 0.25 \text{ Vdc}$

## Temperature Error Band

MPX4101A Series

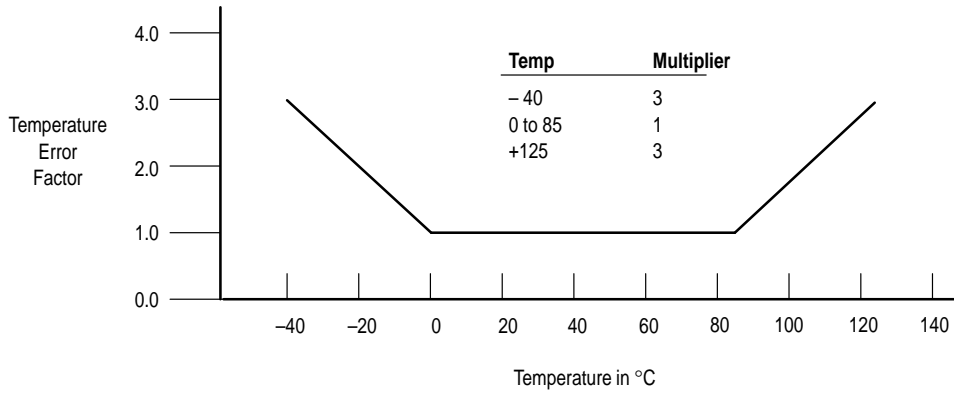

NOTE: The Temperature Multiplier is a linear response from 0° to -40°C and from 85° to 125°C.

## Pressure Error Band

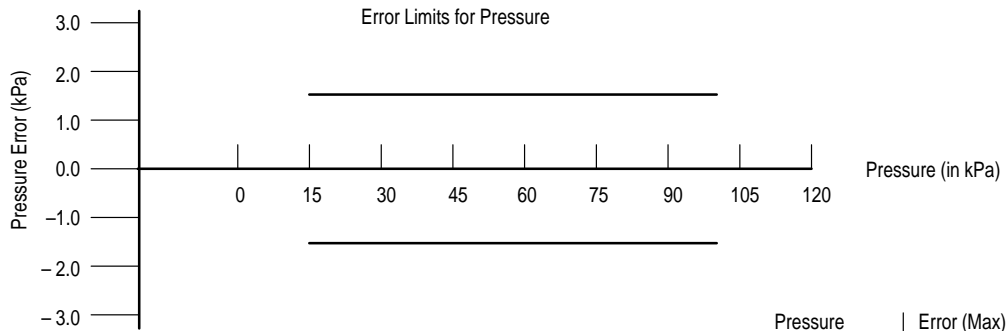

| Pressure        | Error (Max) |
|-----------------|-------------|
| 15 to 102 (kPa) | ± 1.5 (kPa) |

## MPX4101 SERIES

### PRESSURE (P1)/VACUUM (P2) SIDE IDENTIFICATION TABLE

Motorola designates the two sides of the pressure sensor as the Pressure (P1) side and the Vacuum (P2) side. The Pressure (P1) side is the side containing fluorosilicone gel which protects the die from harsh media. The Motorola MPX

pressure sensor is designed to operate with positive differential pressure applied,  $P1 > P2$ .

The Pressure (P1) side may be identified by using the table below:

| Part Number | Case Type | Pressure (P1) Side Identifier |
|-------------|-----------|-------------------------------|
| MPX4101A    | 867-08    | Stainless Steel Cap           |
| MPX4101AP   | 867B-04   | Side with Port Marking        |
| MPX4101AS   | 867E-03   | Side with Port Attached       |
| MPX4101ASX  | 867F-03   | Side with Port Attached       |

### ORDERING INFORMATION

The MPX4101A series MAP silicon pressure sensors are available in the Basic Element, or with pressure port fittings that provide mounting ease and barbed hose connections.

| Device Type     | Options                   | Case Type | MPX Series   |                |
|-----------------|---------------------------|-----------|--------------|----------------|
|                 |                           |           | Order Number | Device Marking |
| Basic Element   | Absolute, Element Only    | 867-08    | MPX4101A     | MPX4101A       |
| Ported Elements | Absolute, Ported          | 867B-04   | MPX4101AP    | MPX4101AP      |
|                 | Absolute, Stove Pipe Port | 867E-03   | MPX4101AS    | MPX4101A       |
|                 | Absolute, Axial Port      | 867F-03   | MPX4101ASX   | MPX4101A       |

**MPX4101 SERIES**

**PACKAGE DIMENSIONS**

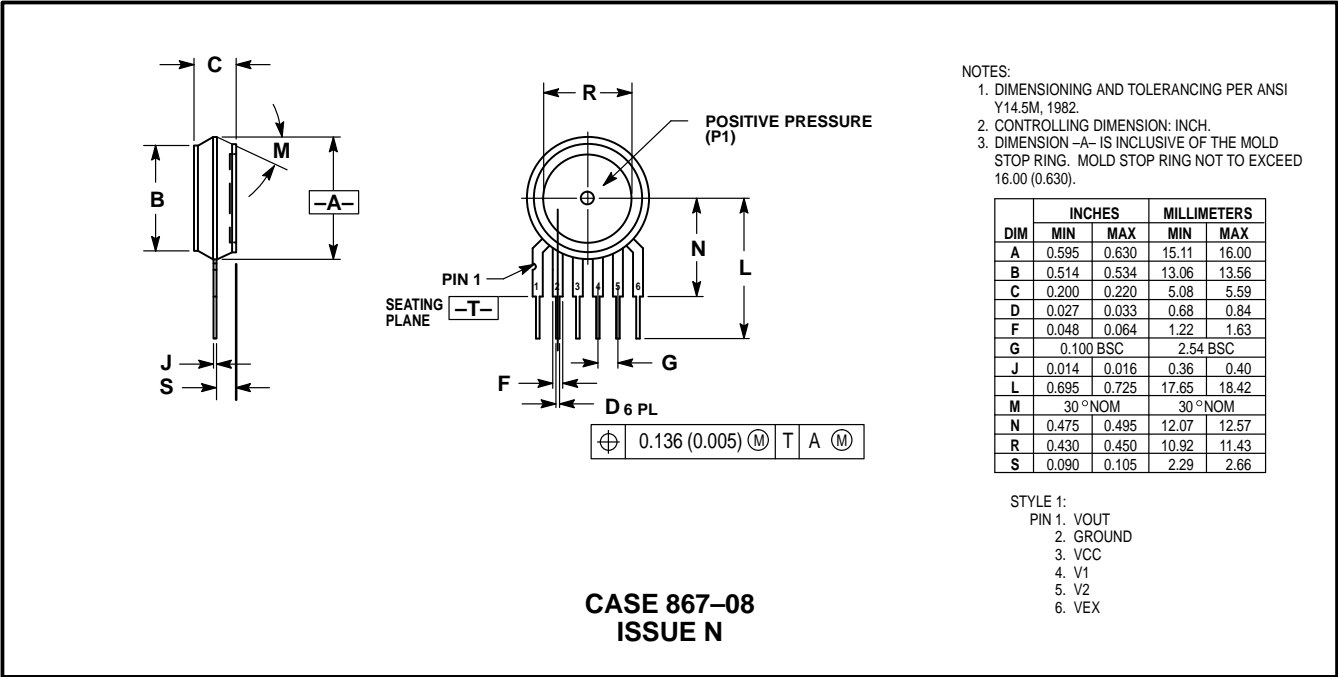

**BASIC ELEMENT (A, D)**

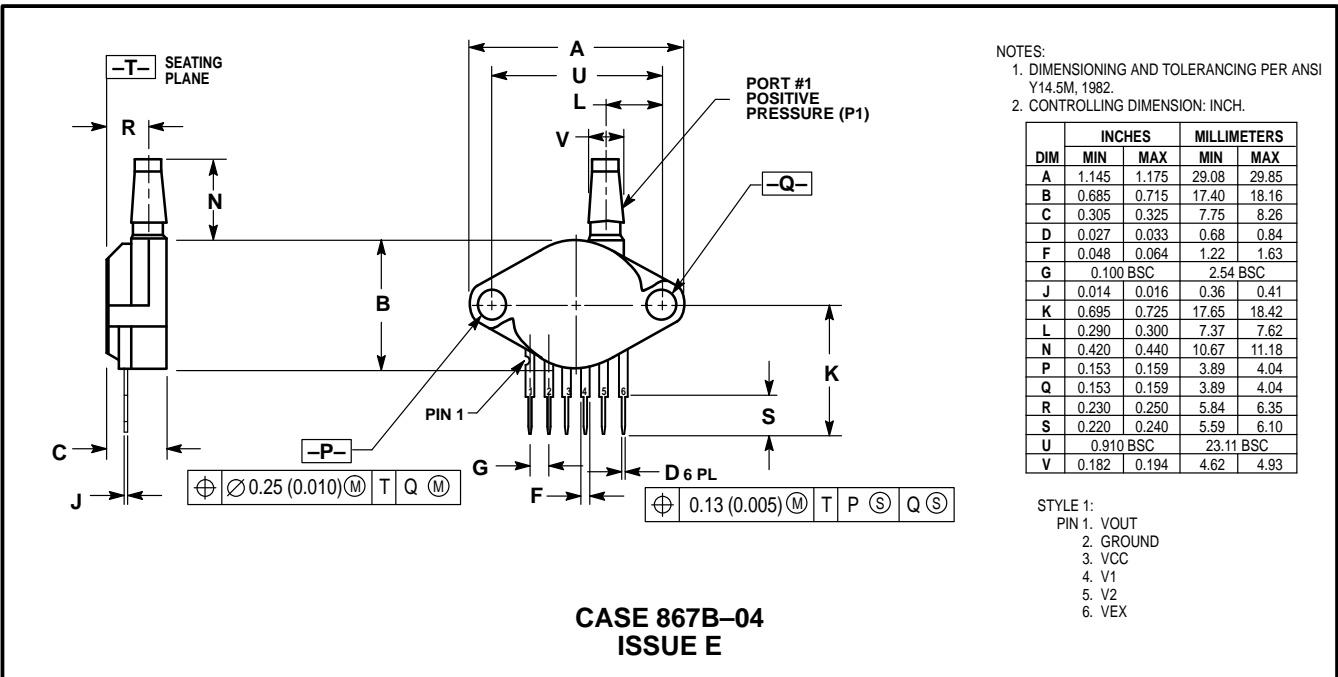

**PRESSURE SIDE PORTED (AP, GP)**

# MPX4101 SERIES

## PACKAGE DIMENSIONS—CONTINUED

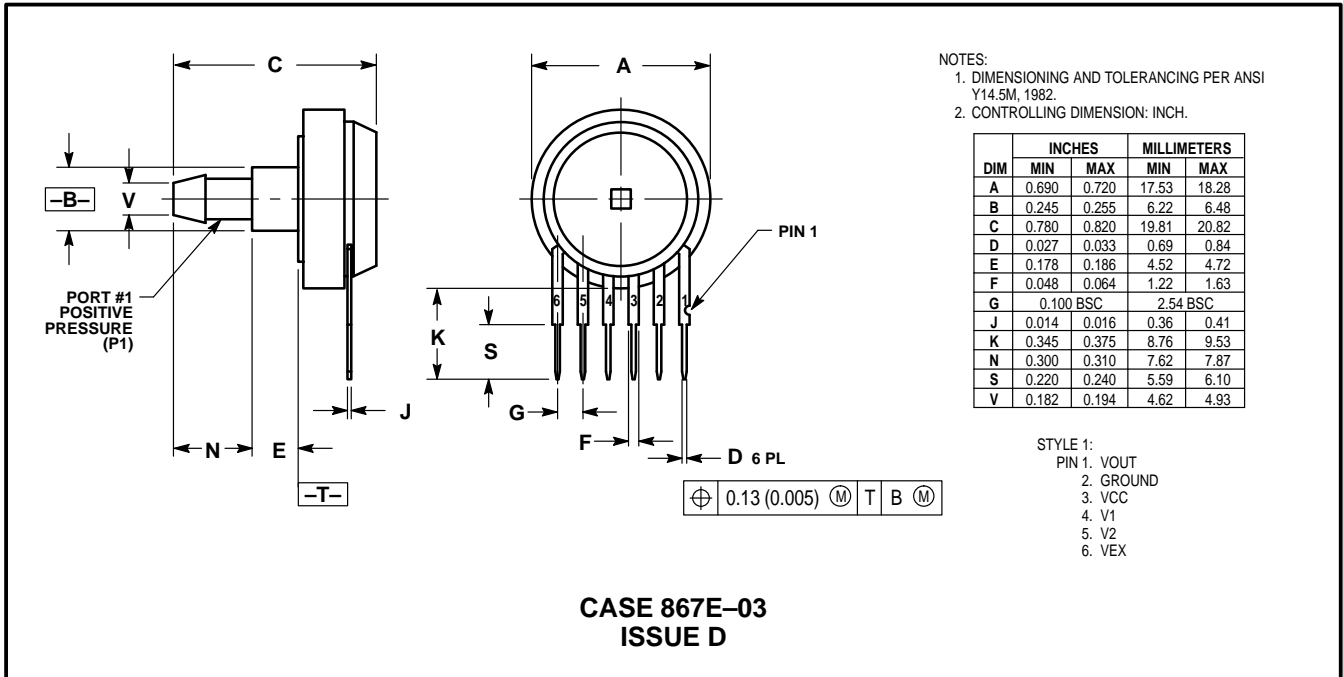

PRESSURE SIDE PORTED (AS, GS)

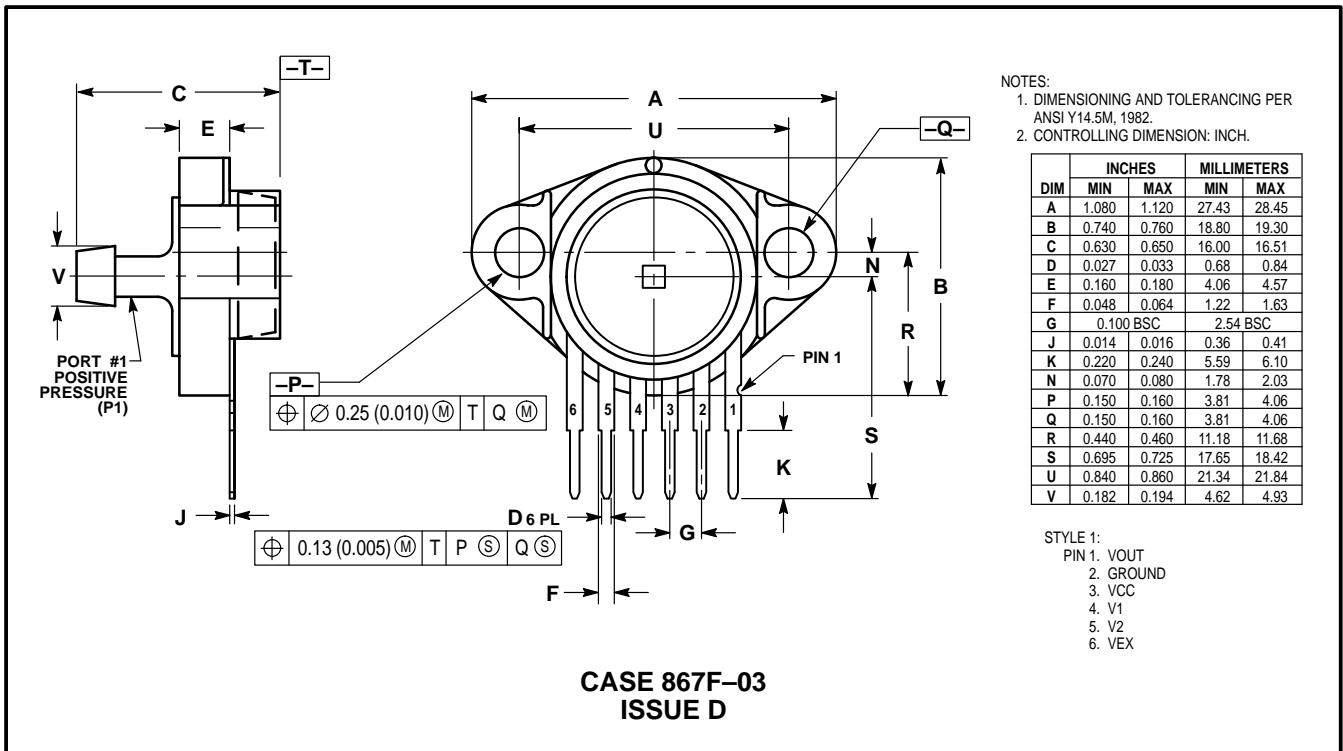

PRESSURE SIDE PORTED (ASX, GSX)

## MPX4101 SERIES

Motorola reserves the right to make changes without further notice to any products herein. Motorola makes no warranty, representation or guarantee regarding the suitability of its products for any particular purpose, nor does Motorola assume any liability arising out of the application or use of any product or circuit, and specifically disclaims any and all liability, including without limitation consequential or incidental damages. "Typical" parameters which may be provided in Motorola data sheets and/or specifications can and do vary in different applications and actual performance may vary over time. All operating parameters, including "Typicals" must be validated for each customer application by customer's technical experts. Motorola does not convey any license under its patent rights nor the rights of others. Motorola products are not designed, intended, or authorized for use as components in systems intended for surgical implant into the body, or other applications intended to support or sustain life, or for any other application in which the failure of the Motorola product could create a situation where personal injury or death may occur. Should Buyer purchase or use Motorola products for any such unintended or unauthorized application, Buyer shall indemnify and hold Motorola and its officers, employees, subsidiaries, affiliates, and distributors harmless against all claims, costs, damages, and expenses, and reasonable attorney fees arising out of, directly or indirectly, any claim of personal injury or death associated with such unintended or unauthorized use, even if such claim alleges that Motorola was negligent regarding the design or manufacture of the part. Motorola and  are registered trademarks of Motorola, Inc. Motorola, Inc. is an Equal Opportunity/Affirmative Action Employer.

Mfax is a trademark of Motorola, Inc.

### How to reach us:

**USA/EUROPE/Locations Not Listed:** Motorola Literature Distribution;  
P.O. Box 5405, Denver, Colorado 80217. 303-675-2140 or 1-800-441-2447

**JAPAN:** Nippon Motorola Ltd.; Tatsumi-SPD-JLDC, 6F Seibu-Butsuryu-Center,  
3-14-2 Tatsumi Koto-Ku, Tokyo 135, Japan. 81-3-3521-8315

**Mfax™:** RMFAX0@email.sps.mot.com – TOUCHSTONE 602-244-6609  
– US & Canada ONLY 1-800-774-1848

**ASIA/PACIFIC:** Motorola Semiconductors H.K. Ltd.; 8B Tai Ping Industrial Park,  
51 Ting Kok Road, Tai Po, N.T., Hong Kong. 852-26629298

**INTERNET:** <http://motorola.com/sps>



**MOTOROLA**