



MRF227

SILICON NPN RF POWER TRANSISTOR

DESCRIPTION: The MRF227 is designed for large signal power amplifier applications operating to 225 MHz

MAXIMUM RATINGS

I_C	0.6 A
V_{CB}	36 V
V_{CE}	16 V
P_{DISS}	8 W @ $T_C = 25^\circ C$
T_J	$-65^\circ C$ to $+200^\circ C$
T_{STG}	$-65^\circ C$ to $+200^\circ C$

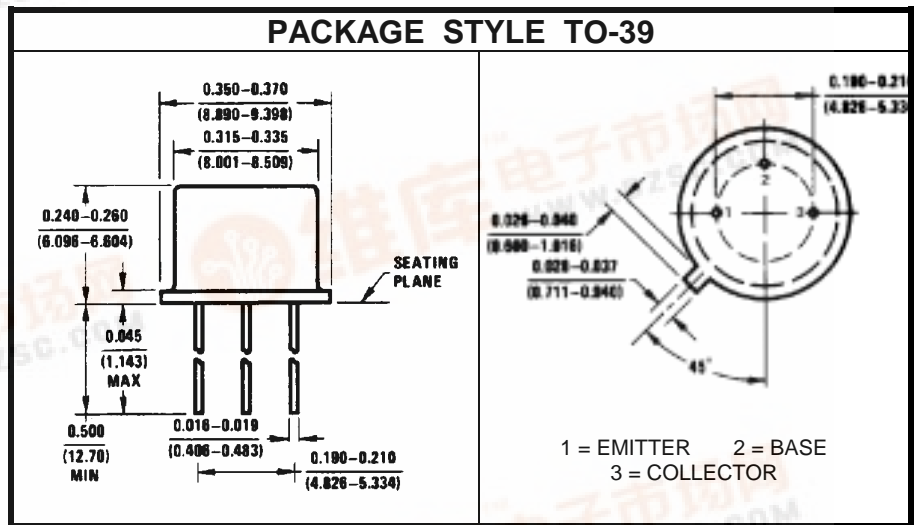

CHARACTERISTICS $T_C = 25^\circ C$

SYMBOL	TEST CONDITIONS	MINIMUM	TYPICAL	MAXIMUM	UNITS
BV_{CEO}	$I_C = 50\text{ mA}$	16			V
BV_{CES}	$I_C = 50\text{ mA}$	36			V
BV_{EBO}	$I_C = 1.0\text{ mA}$	4.0			V
I_{CBO}	$V_{CE} = 15\text{ V}$			1.0	mA
H_{FE}	$V_{CE} = 5.0\text{ V}$ $I_C = 100\text{ mA}$	20		200	---
C_{OB}	$V_{CB} = 12.5\text{ V}$ $f = 1.0\text{ MHz}$			15	Pf
G_{PE}	$P_{OUT} = 3.0\text{ W}$ $V_{CE} = 12.5\text{ V}$ $f = 225\text{ MHz}$	13.5	15		dB
η	$P_{OUT} = 3.0\text{ W}$ $V_{CE} = 12.5\text{ V}$ $f = 225\text{ MHz}$	60			%

