

The RF Line NPN Silicon RF Power Transistor

... designed primarily for wideband large-signal driver and predriver amplifier stages in the 200–500 MHz frequency range.

- Guaranteed Performance at 400 MHz, 28 V
 - Output Power = 20 Watts
 - Power Gain = 10 dB Min
 - Efficiency = 50% Min
- 100% Tested for Load Mismatch at all Phase Angles with 30:1 VSWR
- Gold Metallization System for High Reliability
- Computer-Controlled Wirebonding Gives Consistent Input Impedance

MRF323

**20 W, 400 MHz
RF POWER
TRANSISTOR
NPN SILICON**

MAXIMUM RATINGS

Rating	Symbol	Value	Unit
Collector-Emitter Voltage	V_{CEO}	33	Vdc
Collector-Base Voltage	V_{CBO}	60	Vdc
Emitter-Base Voltage	V_{EBO}	4.0	Vdc
Collector Current — Continuous — Peak	I_C	2.2 3.0	Adc
Total Device Dissipation @ $T_C = 25^\circ\text{C}$ (1) Derate above 25°C	P_D	55 310	Watts mW/ $^\circ\text{C}$
Storage Temperature Range	T_{stg}	-65 to +150	$^\circ\text{C}$

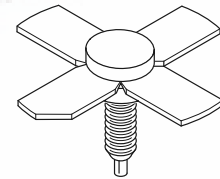

CASE 244-04, STYLE 1

THERMAL CHARACTERISTICS

Characteristic	Symbol	Max	Unit
Thermal Resistance, Junction to Case	$R_{\theta JC}$	3.2	$^\circ\text{C}/\text{W}$

ELECTRICAL CHARACTERISTICS ($T_C = 25^\circ\text{C}$ unless otherwise noted.)

Characteristic	Symbol	Min	Typ	Max	Unit
----------------	--------	-----	-----	-----	------

OFF CHARACTERISTICS

Collector-Emitter Breakdown Voltage ($I_C = 20$ mAdc, $I_B = 0$)	$V_{(BR)CEO}$	33	—	—	Vdc
Collector-Emitter Breakdown Voltage ($I_C = 20$ mAdc, $V_{BE} = 0$)	$V_{(BR)CES}$	60	—	—	Vdc
Collector-Base Breakdown Voltage ($I_C = 20$ mAdc, $I_E = 0$)	$V_{(BR)CBO}$	60	—	—	Vdc
Emitter-Base Breakdown Voltage ($I_E = 2.0$ mAdc, $I_C = 0$)	$V_{(BR)EBO}$	4.0	—	—	Vdc
Collector Cutoff Current ($V_{CB} = 30$ Vdc, $I_E = 0$)	I_{CBO}	—	—	2.0	mAdc

ON CHARACTERISTICS

DC Current Gain ($I_C = 1.0$ Adc, $V_{CE} = 5.0$ Vdc)	h_{FE}	20	—	80	—
---	----------	----	---	----	---

NOTE: (continued)
1. This device is designed for RF operation. The total device dissipation rating applies only when the device is operated as an RF amplifier.

ELECTRICAL CHARACTERISTICS — continued ($T_C = 25^\circ\text{C}$ unless otherwise noted.)

Characteristic	Symbol	Min	Typ	Max	Unit
DYNAMIC CHARACTERISTICS					
Output Capacitance ($V_{CB} = 28\text{ Vdc}$, $I_E = 0$, $f = 1.0\text{ MHz}$)	C_{ob}	—	20	24	pF
FUNCTIONAL TESTS (Figure 1)					
Common-Emitter Amplifier Power Gain ($V_{CC} = 28\text{ Vdc}$, $P_{out} = 20\text{ W}$, $f = 400\text{ MHz}$)	G_{PE}	10	11	—	dB
Collector Efficiency ($V_{CC} = 28\text{ Vdc}$, $P_{out} = 20\text{ W}$, $f = 400\text{ MHz}$)	η	50	60	—	%
Load Mismatch ($V_{CC} = 28\text{ Vdc}$, $P_{out} = 20\text{ W}$, $f = 400\text{ MHz}$, $V_{SWR} = 30:1$ all phase angles)	ψ	No Degradation in Output Power			

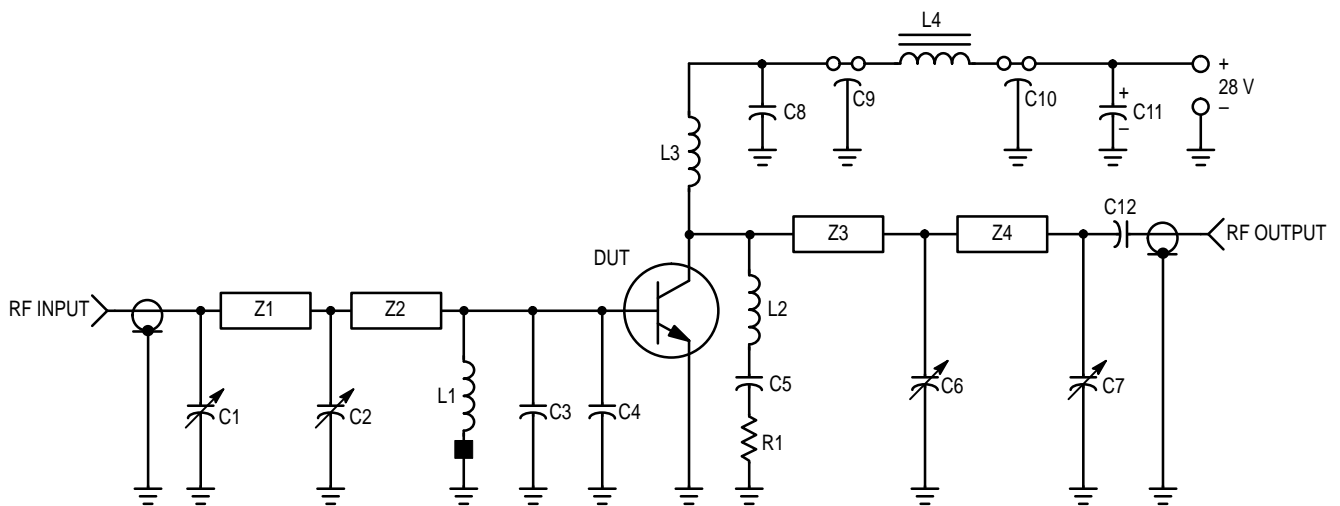

- C1, C2, C6 — 1.0–20 pF Johanson Trimmer (JMC 5501)
- C3, C4 — 47 pF ATC Chip Capacitor
- C5, C8 — 0.1 μF Erie Redcap
- C7 — 0.5–10 pF Johanson Trimmer (JMC 5201)
- C9, C10 — 680 pF Feedthru
- C11 — 1.0 μF 50 Volt Tantalum
- C12 — 0.018 μF Vitramon Chip Capacitor
- L1 — 0.33 μH Molded Choke with Ferroxcube Bead
(Ferroxcube 56–590–65/4B) on Ground End

- L2 — 6 Turns #20 Enamel, 1/4" ID, Closewound
- L3 — 4 Turns #20 Enamel, 1/8" ID, Closewound
- L4 — Ferroxcube VK200–19/4B
- R1 — 5.1 Ω 1/4 Watt
- Z1 — Microstrip 0.1" W x 1.35" L
- Z2 — Microstrip 0.1" W x 0.55" L
- Z3 — Microstrip 0.1" W x 0.8" L
- Z4 — Microstrip 0.1" W x 1.75" L
- Board — Glass Teflon $\epsilon_r = 2.56$, $t = 0.062"$
- Input/Output Connectors — Type N

Figure 1. 400 MHz Test Circuit Schematic

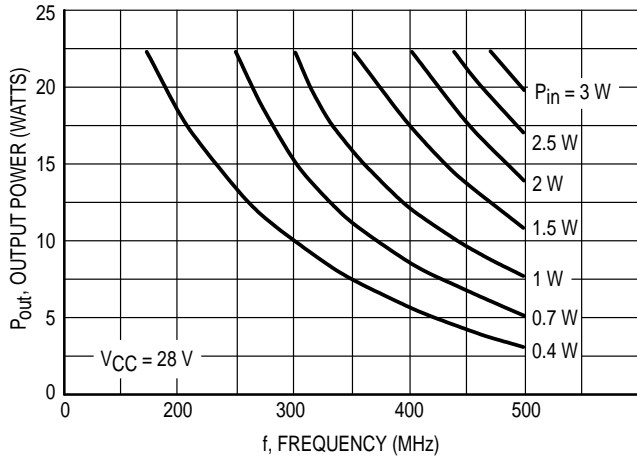

Figure 2. Output Power versus Frequency

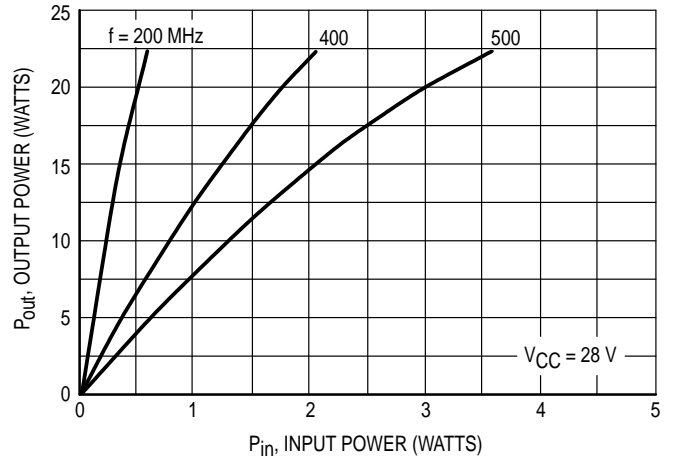

Figure 3. Output Power versus Input Power

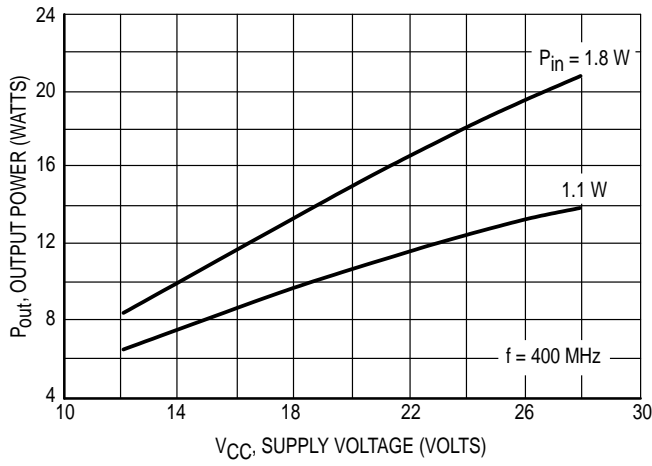

Figure 4. Output Power versus Supply Voltage

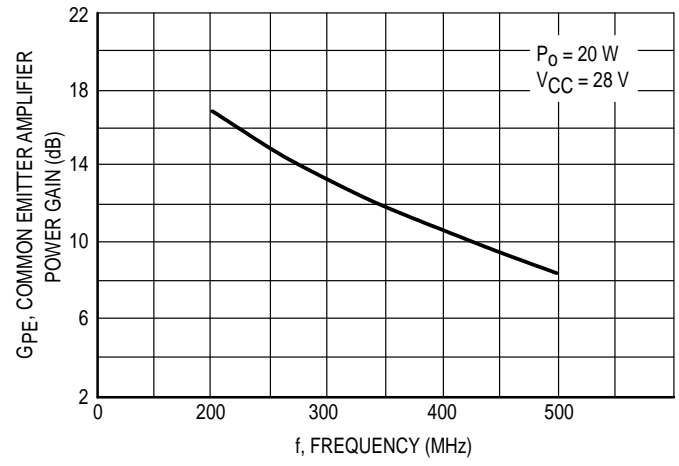
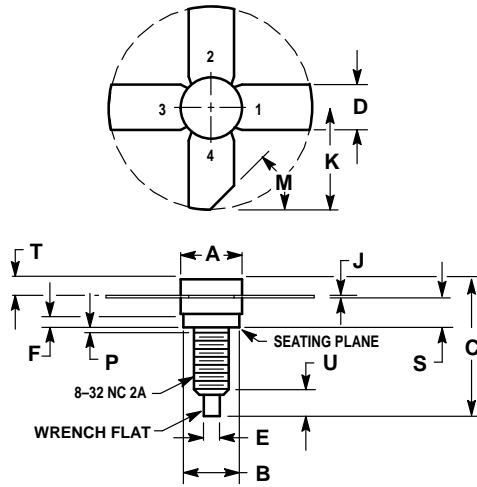

Figure 5. Power Gain versus Frequency

PACKAGE DIMENSIONS



DIM	MILLIMETERS		INCHES	
	MIN	MAX	MIN	MAX
A	7.06	7.26	0.278	0.286
B	6.20	6.50	0.244	0.256
C	14.99	16.51	0.590	0.650
D	5.46	5.96	0.215	0.235
E	1.40	1.65	0.055	0.065
G	1.52	—	0.060	—
J	0.08	0.17	0.003	0.007
K	11.05	—	0.435	—
M	45° NOM		45° NOM	
P	—	1.27	—	0.050
S	3.00	3.25	0.118	0.128
T	1.40	1.77	0.055	0.070
U	2.92	3.68	0.115	0.145

STYLE 1:
 PIN 1. EMITTER
 2. BASE
 3. EMITTER
 4. COLLECTOR

**CASE 244-04
 ISSUE J**

Motorola reserves the right to make changes without further notice to any products herein. Motorola makes no warranty, representation or guarantee regarding the suitability of its products for any particular purpose, nor does Motorola assume any liability arising out of the application or use of any product or circuit, and specifically disclaims any and all liability, including without limitation consequential or incidental damages. "Typical" parameters can and do vary in different applications. All operating parameters, including "Typicals" must be validated for each customer application by customer's technical experts. Motorola does not convey any license under its patent rights nor the rights of others. Motorola products are not designed, intended, or authorized for use as components in systems intended for surgical implant into the body, or other applications intended to support or sustain life, or for any other application in which the failure of the Motorola product could create a situation where personal injury or death may occur. Should Buyer purchase or use Motorola products for any such unintended or unauthorized application, Buyer shall indemnify and hold Motorola and its officers, employees, subsidiaries, affiliates, and distributors harmless against all claims, costs, damages, and expenses, and reasonable attorney fees arising out of, directly or indirectly, any claim of personal injury or death associated with such unintended or unauthorized use, even if such claim alleges that Motorola was negligent regarding the design or manufacture of the part. Motorola and  are registered trademarks of Motorola, Inc. Motorola, Inc. is an Equal Opportunity/Affirmative Action Employer.

Literature Distribution Centers:

USA: Motorola Literature Distribution; P.O. Box 20912; Phoenix, Arizona 85036.

EUROPE: Motorola Ltd.; European Literature Centre; 88 Tanners Drive, Blakelands, Milton Keynes, MK14 5BP, England.

JAPAN: Nippon Motorola Ltd.; 4-32-1, Nishi-Gotanda, Shinagawa-ku, Tokyo 141, Japan.

ASIA PACIFIC: Motorola Semiconductors H.K. Ltd.; Silicon Harbour Center, No. 2 Dai King Street, Tai Po Industrial Estate, Tai Po, N.T., Hong Kong.



MOTOROLA

MP5001D