

OKI Semiconductor

This version: Nov. 1997
Previous version: Jul. 1996

MSC1164

20-Bit Grid/Anode Driver

GENERAL DESCRIPTION

The MSC1164 is a monolithic IC using the Bi-CMOS process technology for hybridizing CMOS and bipolar transistors on the same chip. The logic portion such as the input stage, shift register and latch is fabricated by CMOS and the output driver requiring a high withstand voltage is fabricated by bipolar transistors.

Since a 32-pin plastic SSOP package is used, the display unit size can be reduced.

FEATURES

The MSC1164 is designed as a VFD grid/anode driver with emitter-follower force output with 20-bit active pull-down and built-in 20-bit shift register and latch.

- Logic Supply Voltage (V_{CC}) : 5V
- Driver Supply Voltage (V_{HV}) : 65V
- Driver Output Current
 - I_{OHVH1} : -40mA (Only one driver output: "H")
 - I_{OHVH2} : -2mA (All driver outputs: "H")
 - I_{OHVL} : 2mA
- 20-bit output (with latch circuit)
- 20-bit shift register
- Clock frequency : 4MHz
- Package options:
 - 32-pin plastic SSOP (SSOP32-P-430-1.00-K) (Product name: MSC1164GS-K)
 - 30-pin plastic shrink DIP (SDIP30-P-400-1.78) (Product name: MSC1164SS)

BLOCK DIAGRAM

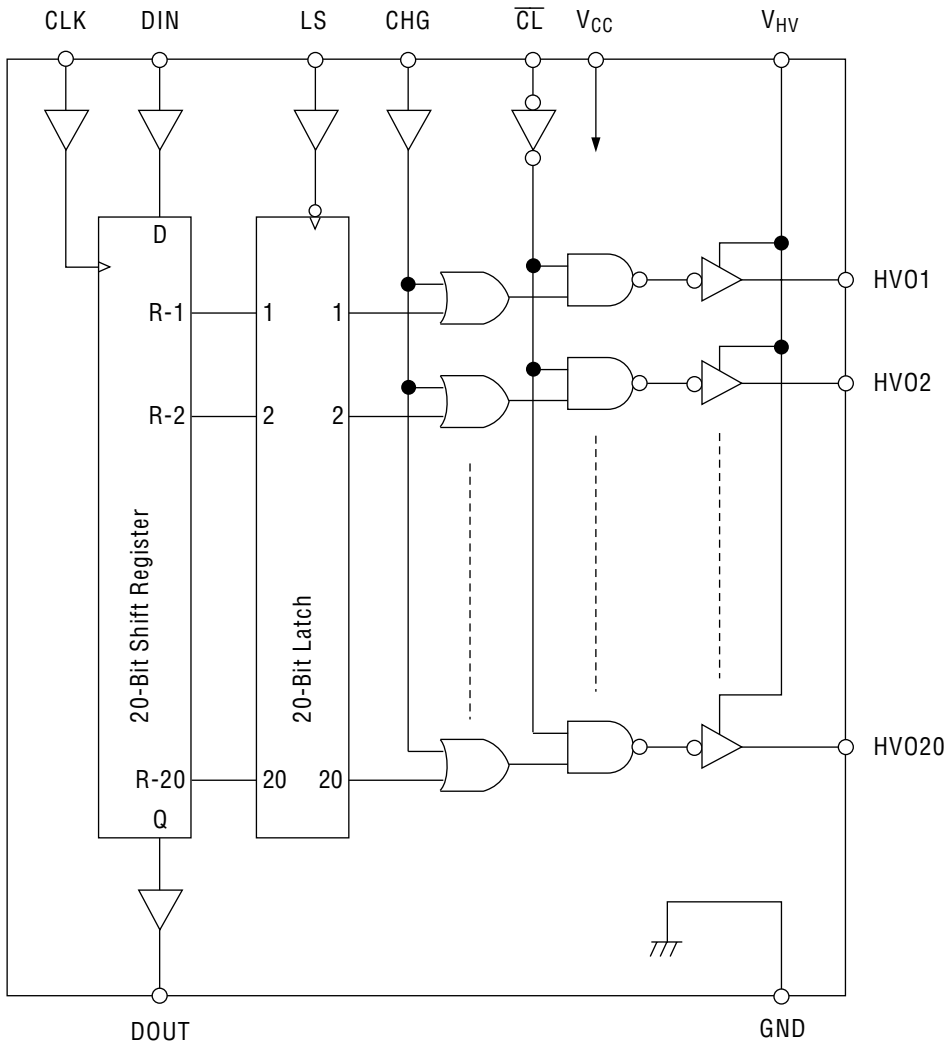

INPUT AND OUTPUT CONFIGURATION

Schematic Diagrams of Logic Portion Input and Output Circuits

Input Pin

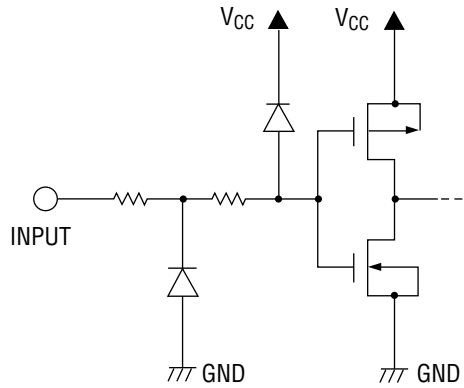

Output Pin

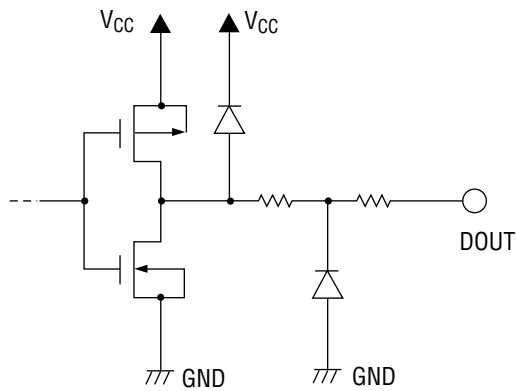

Schematic Diagram of Driver Output Circuit

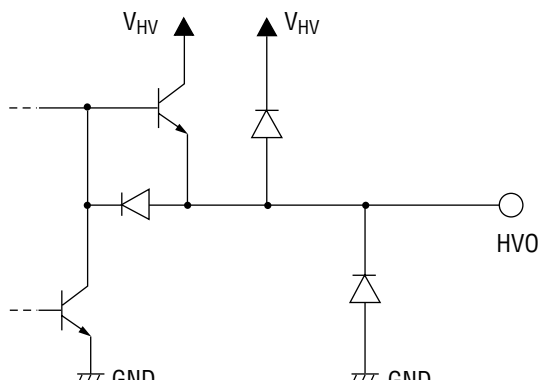

PIN CONFIGURATION (TOP VIEW)

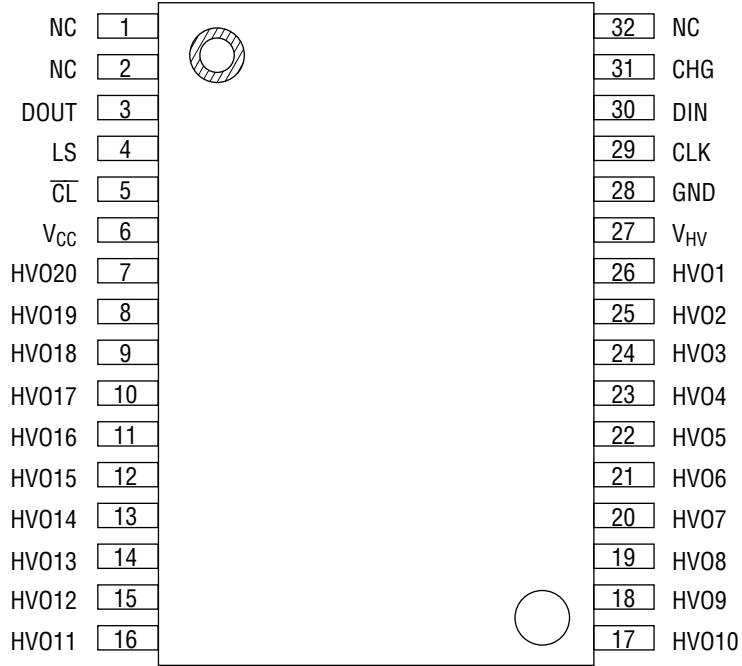

NC: No-connection pin
32-Pin Plastic SSOP

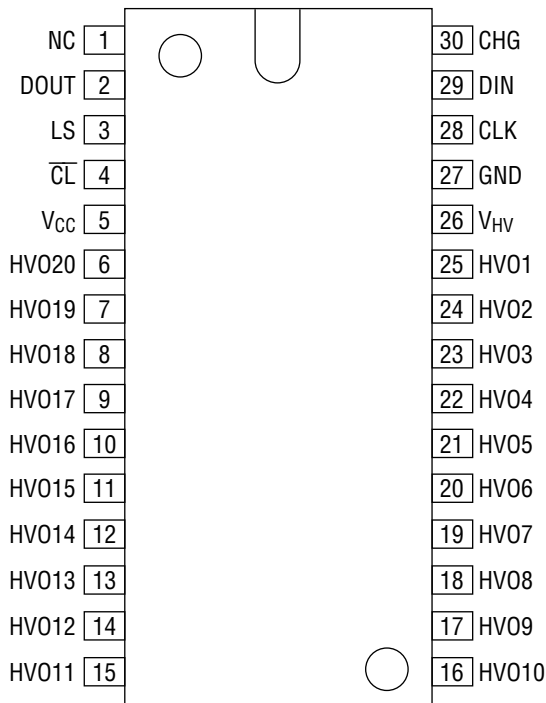

NC: No-connection pin
30-Pin Plastic Shrink DIP

PIN DESCRIPTION

| Function | Pin | Symbol | Description |
|-------------------------|--------|-----------------|---|
| Driver Output | 26 - 7 | HV01 - HV020 | Driver output pin, applicable to each bit of shift register. |
| Driver Power Supply | 27 | V _{HV} | Power supply pin for driver circuit. |
| Driver GND Logic GND | 28 | GND | GND pin for the driver circuit. GND pin for the logic circuit. |
| Clear Input | 5 | \overline{CL} | Clear input pin with pull-up resistor. Normally "H" level. In this condition, the driver outputs "H" or "L" according to the corresponding latch output level. Setting this pin to "L" enables the driver output to be fixed at "L" irrespective of latch output. |
| Latch Strobe Input | 4 | LS | Latch strobe input pin with neither pull-up nor pull-down resistor. When LS is "H", the output of the shift register becomes that of the latch circuit. When LS is "L", the latch circuit holds the contents of the shift register that are immediately before LS goes "L". |
| Data Input | 30 | DIN | Shift register input pin with neither pull-up nor pull-down resistor. Display data is input in synchronization with clock. (Positive Logic) |
| Logic Power Supply | 6 | V _{CC} | Power supply pin for logic (except driver). V _{CC} should be 4.5V to 5.5V. |
| Data Output | 3 | DOUT | Serial output pin for shift register. |
| Clock Input | 29 | CLK | Clock input pin. Data of shift register is shifted from one stage to the next at the rising edge of clock. |
| Test Input | 31 | CHG | Test input pin with a pull-down resistor. Normally "L". If \overline{CL} = "H" in this condition, the driver outputs "H" or "L" according to the corresponding latch output. |

Note: Pin numbers shown are for 32-pin plastic SSOP.

ABSOLUTE MAXIMUM RATINGS

| Parameter | Symbol | Condition | Rating | Unit | Note |
|-------------------------------|------------------|---|------------------------------|------|------|
| Logic Supply Voltage | V _{CC} | Applicable to logic supply voltage pin | -0.3 to +65 | V | 1 |
| Driver Supply Voltage | V _{HV} | Applicable to driver supply voltage pin | V _{CC} to 70 | V | 1, 2 |
| Input Voltage | V _{IN} | Applicable to all input pins | -0.3 to V _{CC} +0.3 | V | 1 |
| Data Output Voltage | V _{OD} | Applicable to data output pin | -0.3 to V _{CC} +0.3 | V | 1 |
| Driver Driving Frequency | f _{DRV} | Duty cycle 50% max | 0 to 15 | kHz | — |
| Power Dissipation | P _D | T _a ≤ 25°C | 790 | mW | — |
| Thermal Resistance of Package | R _{j-a} | — | 158 | °C/W | 3 |
| Storage Temperature | T _{STG} | — | -55 to +150 | °C | — |

- Notes: 1) Maximum Supply Voltage with respect to GND
 2) Stresses beyond "Absolute Maximum Rating" may cause permanent damage to the device.
 3) Thermal resistance of the package (between junction and atmosphere)
 The junction temperature (T_j) expressed by the equation below must not exceed 150°C.
 $T_j = P \times R_{j-a} + T_a$ (P: Maximum power consumption)

RECOMMENDED OPERATING CONDITIONS

| Parameter | Symbol | Condition | Min. | Max. | Unit | |
|----------------------------------|-----------------------|---|---------------|------|--------------|---|
| Logic Supply Voltage | V_{CC} | Applicable to logic supply voltage pin | 4.5 | 5.5 | V | |
| Driver Supply Voltage | V_{HV} | Applicable to driver supply voltage pin | 10 | 65 | V | |
| High Level Input Voltage | V_{IH} | Applicable to all input pins | $V_{CC}=4.5V$ | 3.6 | — | V |
| | | | $V_{CC}=5.5V$ | 4.4 | — | V |
| Low Level Input Voltage | V_{IL} | Applicable to all input pins | $V_{CC}=4.5V$ | — | 0.9 | V |
| | | | $V_{CC}=5.5V$ | — | 1.1 | V |
| High Level Driver Output Current | I_{OHVH1} | Only one driver output is High Other driver outputs are High | — | -40 | mA | |
| High Level Driver Output Current | I_{OHVH2} | All driver output pins are High | — | -2 | mA | |
| Low Level Driver Output Current | I_{OHVL} | Applicable to all driver output pins | — | 2 | mA | |
| CLK Frequency | f_{ϕ} | See timing diagram | — | 4 | MHz | |
| CLK Pulse Width | t_{WCLK} | See timing diagram | 75 | — | ns | |
| Data in Setup Time | t_{DS} | See timing diagram | 50 | — | ns | |
| Data in Hold Time | t_{DH} | See timing diagram | 50 | — | ns | |
| LS Pulse Width | t_{WLS} | See timing diagram | 80 | — | ns | |
| CLK-LS Delay Time | t_{DCL} | See timing diagram | 50 | — | ns | |
| LS-CLK Delay Time | t_{DLC} | See timing diagram | 0 | — | ns | |
| LS-CHG Delay Time | t_{DLCHG} | See timing diagram | 0 | — | μ s | |
| LS- \overline{CL} Delay Time | $t_{DL\overline{CL}}$ | See timing diagram | 0 | — | μ s | |
| CHG Pulse Width | t_{WCHG} | See timing diagram | 2 | — | μ s | |
| \overline{CL} Pulse Width | $t_{W\overline{CL}}$ | See timing diagram | 2 | — | μ s | |
| Operating Temperature | T_{op} | — | -40 | 85 | $^{\circ}$ C | |

ELECTRICAL CHARACTERISTICS

DC Characteristics

($V_{CC}=5V\pm 10\%$, $V_{HV}=10V$ to $65V$, $T_a=-40^\circ C$ to $+85^\circ C$)

| Parameter | Symbol | Condition | | Min. | Typ. | Max. | Unit |
|----------------------------------|------------|--------------------------|--|------------|------|---------|---------|
| Logic Supply Current | I_{CC1} | No load $V_{CC}=5.5V$ | All input: Low | — | 2.3 | 3.4 | mA |
| | I_{CC2} | | All input: High, All driver output: High, $T_a=25^\circ C$ | — | 0.5 | 1.0 | |
| Driver Supply Current | I_{HV1} | No load $V_{CC}=5.5V$ | All driver output: Low | — | — | 1 | μA |
| | I_{HV2} | | All driver output: High, $T_a=25^\circ C$ | — | 1.3 | 2.0 | mA |
| High Level Input Voltage | V_{IH} | — | $V_{CC}=4.5V$ | 3.15 | — | — | V |
| | | | $V_{CC}=5.5V$ | 3.85 | — | — | V |
| Low Level Input Voltage | V_{IL} | — | $V_{CC}=4.5V$ | — | — | 1.35 | V |
| | | | $V_{CC}=5.5V$ | — | — | 1.65 | V |
| Input Leakage Current | I_{IN} | $T_a=25^\circ C$ | | — | — | ± 1 | μA |
| Input Capacitance | C_{IN} | $T_a=25^\circ C$ | | — | 15 | — | pF |
| High Level Data Output Voltage | V_{ODH1} | $I_O=-20\mu A$ | $V_{CC}=4.5V$ | 4.2 | — | — | V |
| | | | $V_{CC}=5.5V$ | 5.2 | — | — | V |
| Low Level Data Output Voltage | V_{ODL1} | $I_O=20\mu A$ | $V_{CC}=4.5V$ | — | — | 0.2 | V |
| | | | $V_{CC}=5.5V$ | — | — | 0.2 | V |
| High Level Data Output Voltage | V_{ODH2} | $I_O=-0.1mA$ | $V_{CC}=4.5V$ | 3.5 | — | — | V |
| | | | $V_{CC}=5.5V$ | 4.5 | — | — | V |
| Low Level Data Output Voltage | V_{ODL2} | $I_O=0.1mA$ | $V_{CC}=4.5V$ | — | — | 1.1 | V |
| | | | $V_{CC}=5.5V$ | — | — | 1.1 | V |
| High Level Driver Output Voltage | V_{OHVH} | $I_{OHV}=-40mA$ | | $V_{HV}-4$ | — | — | V |
| Low Level Driver Output Voltage | V_{OHVL} | $I_{OHV}=2mA$ | | — | — | 3.0 | V |

AC Characteristics

($V_{CC}=5V$, $V_{HV}=65V$, $T_a=25^\circ C$)

| Parameter | Symbol | Remarks | Min. | Typ. | Max. | Unit |
|--------------------------|-----------|-------------------------------------|------|------|------|---------|
| CLK-DOUT Delay Time | t_{PD} | See timing diagram and test circuit | — | 100 | 150 | ns |
| Delay Time Low to High | t_{DLH} | See timing diagram and test circuit | — | 0.3 | 1 | μs |
| Transit Time Low to High | t_{TLH} | See timing diagram and test circuit | — | 2 | 5 | μs |
| Delay Time High to Low | t_{DHL} | See timing diagram and test circuit | — | 0.3 | 1 | μs |
| Transit Time High to Low | t_{THL} | See timing diagram and test circuit | — | 2 | 5 | μs |

TIMING DIAGRAM

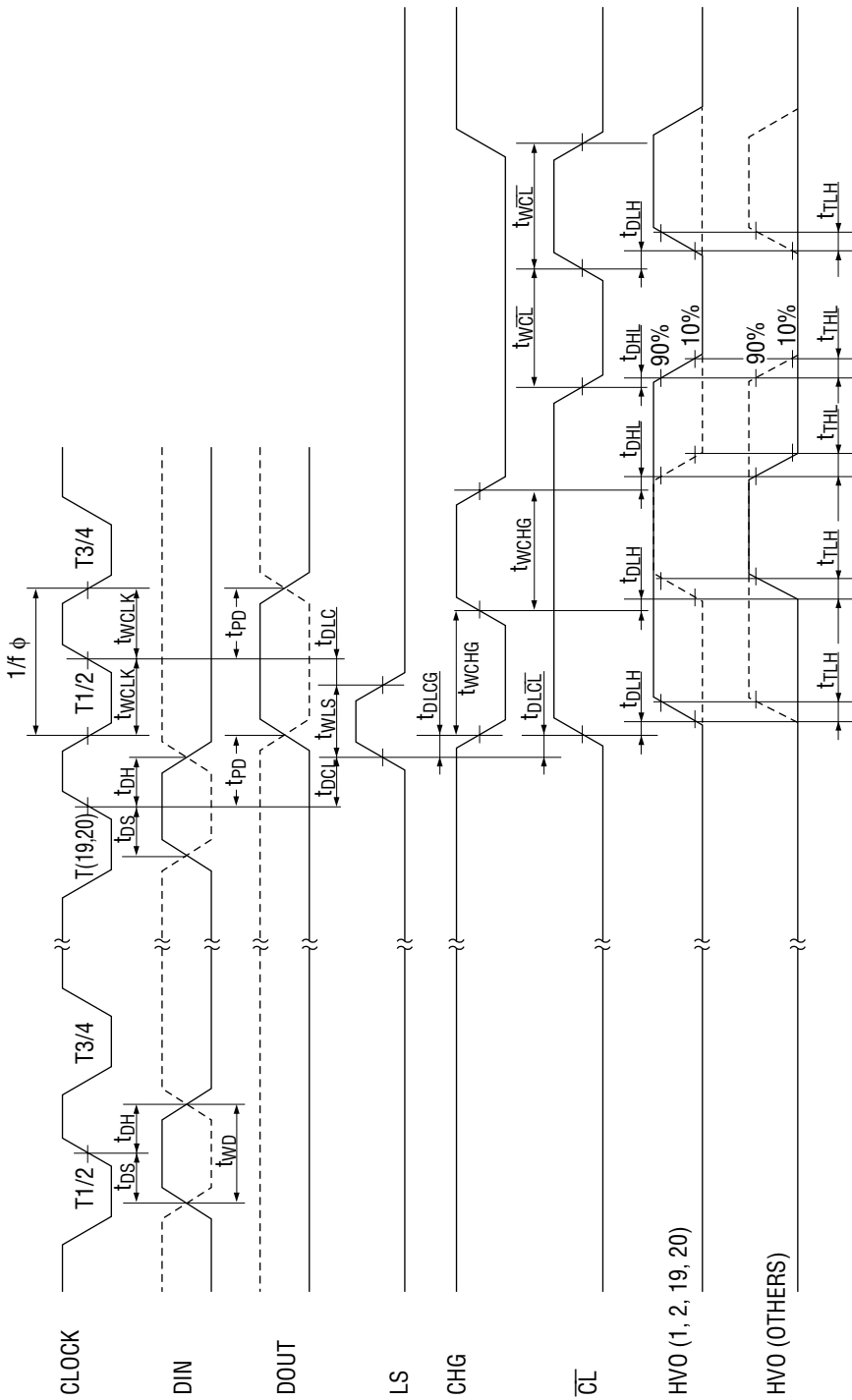

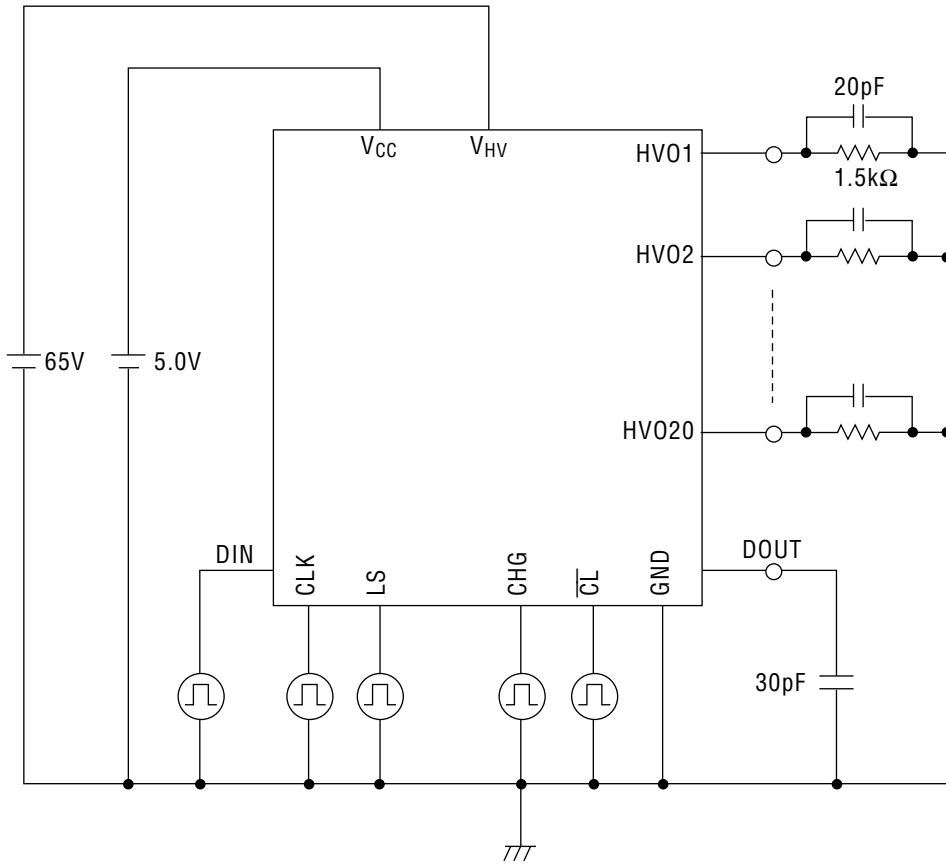

Test circuit



FUNCTIONAL DESCRIPTION

Function Table

| CLK | DIN | R-1 | R-2 | R-3 | R-4 | | R-20 | DOUT |
|---|-----|-----|-----|-----|-----|-------|------|------|
|  | H | H | R1n | R2n | R3n | | R19n | R19n |
|  | L | L | R1n | R2n | R3n | | R19n | R19n |

| \overline{CL} | CHG | LS | R.X | HVO.X |
|-----------------|-----|----|-----|-------|
| L | X | X | X | L |
| H | H | X | X | H |
| H | L | H | H | H |
| H | L | H | L | L |
| H | L | L | X | NC |

L: Low Level, H: High Level, X: Don't Care, NC: Change

NOTES ON USE

- The MSC1164 is designed as a grid/anode driver of VFD.
 The data applied to the data input pin is read into the shift register at the rising edge of the clock and shifted sequentially to the shift register synchronizing with the clock.
 The shift register output drives the output driver, passing through the latch and the NOR circuit.
 Setting the \overline{CL} pin to "L" makes all driver outputs go into "L". This function can be used for setting display blanking.
- The contents of the shift register are undefined after power is turned on.
 Therefore, two or more driver outputs may go into "H" at the same time after power-on. (If it happens, an overloading beyond the power dissipation limit may occur to cause a device break-down.)
 To avoid this, take the following procedure:

 - 1) Turn on the power of the logic portion while holding the \overline{CL} pin to "L".
 - 2) Turn on the power of the driver portion.
 - 3) Apply a "L" level signal to the DIN pin and send clock pulses by the specified number of grids to reset ("L") the entire contents of the shift register.
 - 4) Initialize the driver outputs to "L".

PACKAGE DIMENSIONS

(Unit : mm)

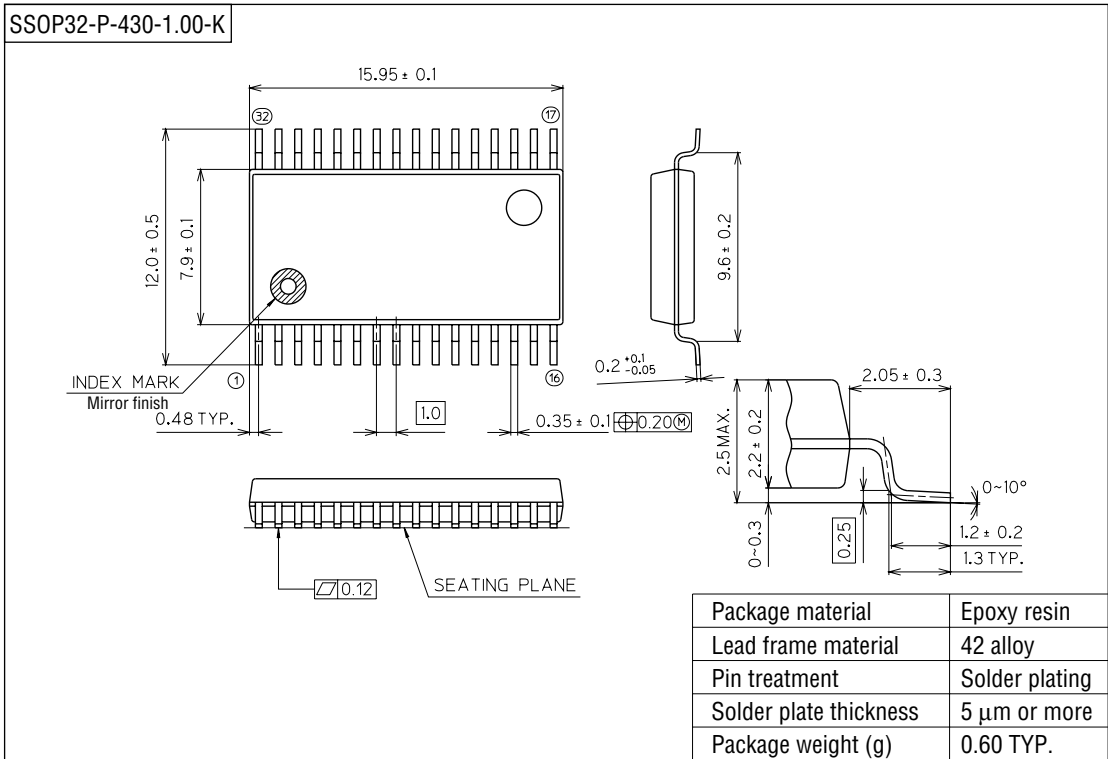

Notes for Mounting the Surface Mount Type Package

The SOP, QFP, TSOP, SOJ, QFJ (PLCC), SHP and BGA are surface mount type packages, which are very susceptible to heat in reflow mounting and humidity absorbed in storage. Therefore, before you perform reflow mounting, contact Oki's responsible sales person for the product name, package name, pin number, package code and desired mounting conditions (reflow method, temperature and times).

(Unit : mm)

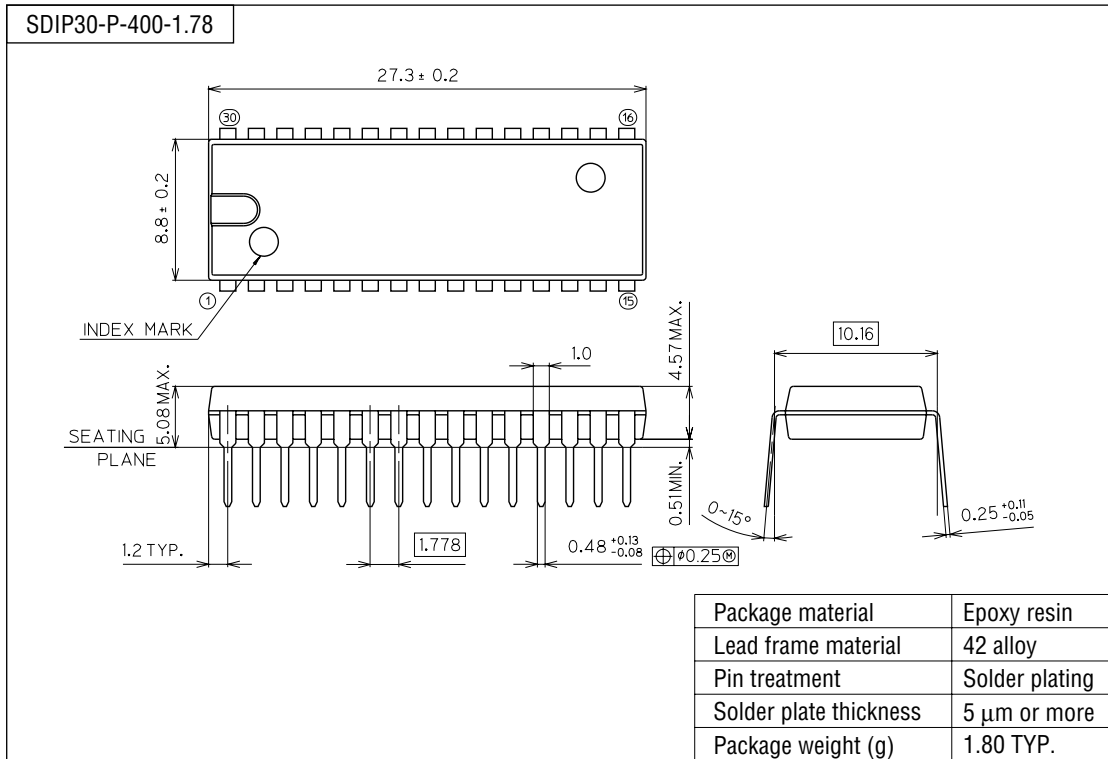

Notes for Mounting the Surface Mount Type Package

The SOP, QFP, TSOP, SOJ, QFJ (PLCC), SHP and BGA are surface mount type packages, which are very susceptible to heat in reflow mounting and humidity absorbed in storage. Therefore, before you perform reflow mounting, contact Oki's responsible sales person for the product name, package name, pin number, package code and desired mounting conditions (reflow method, temperature and times).