



140 COMMERCE DRIVE
MONTGOMERYVILLE, PA
18936-1013
PHONE: (215) 631-9840
FAX: (215) 631-9855

MSC1175M

**RF & MICROWAVE TRANSISTORS
AVIONICS APPLICATIONS**

Features

- 1025 – 1150 MHz
- 50 VOLTS
- INTERNAL INPUT/OUTPUT MATCHING
- P_{OUT} = 175 WATTS
- G_p = 7.7 dB MINIMUM
- COMMON BASE CONFIGURATION



DESCRIPTION:

The MSC1175M is a NPN bipolar transistor specifically designed for high peak pulse power applications such as DME/TACAN. This device is capable of withstanding a minimum 20:1 load VSWR at any phase angle under full rated conditions. Internal impedance matching provides consistent broadband performance.

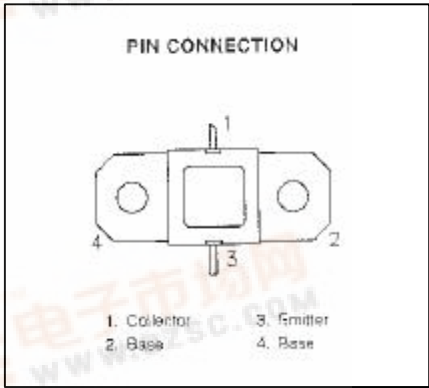

ABSOLUTE MAXIMUM RATINGS (T_{case} = 25°C)

Symbol	Parameter	Value	Unit
P _{DISS}	Power Dissipation	400	W
I _C	Device Current	12	A
V _{CC}	Collector-Supply Voltage*	55	V
T _J	Junction Temperature	250	°C
T _{STG}	Storage Temperature	-65 to +200	°C

Thermal Data

R _{TH(J-C)}	Thermal Resistance Junction-case	0.3	°C/W
----------------------	----------------------------------	-----	------



MSC1175M
ELECTRICAL SPECIFICATIONS (T_{case} = 25°C)
STATIC

Symbol	Test Conditions		Value			Unit
			Min.	Typ.	Max.	
BV_{CBO}	I_C = 10 mA	I_E = 0 mA	65	---	---	V
BV_{EBO}	I_E = 1 mA	I_C = 0 mA	3.5	---	---	V
BV_{CER}	I_C = 15 mA	R_{BE} = 10 Ω	65	---	---	V
I_{CES}	V_{CE} = 50 V		---	---	12.5	mA
h_{FE}	V_{CE} = 5 V	I_C = 1 A	15	---	120	---

DYNAMIC

Symbol	Test Conditions			Value			Unit
				Min.	Typ.	Max.	
P_{OUT}	f = 1025 - 1150 MHz	P_{IN} = 30 W	V_{CC} = 50 V	175	190	---	W
η_C	f = 1025 - 1150 MHz	P_{IN} = 30 W	V_{CC} = 50 V	40	42	---	%
G_P	f = 1025 - 1150 MHz	P_{IN} = 30 W	V_{CC} = 50 V	7.7	8.0	---	dB
Conditions	Pulse Width = 10μS Duty Cycle = 1%						

MSC1175M

IMPEDANCE DATA

FREQ	Z _{IN} (Ω)	Z _{CL} (Ω)
1025 MHz	2.3 + j5.1	2.4 - j4.2
1090 MHz	2.0 + j4.5	2.0 - j3.5
1150 MHz	2.2 + j3.3	2.5 - j2.5

V_{CC} = 50V
P_{IN} = 30W
Normalized to 50Ω

TEST CIRCUIT

Ref.: Dwg. No. C127469

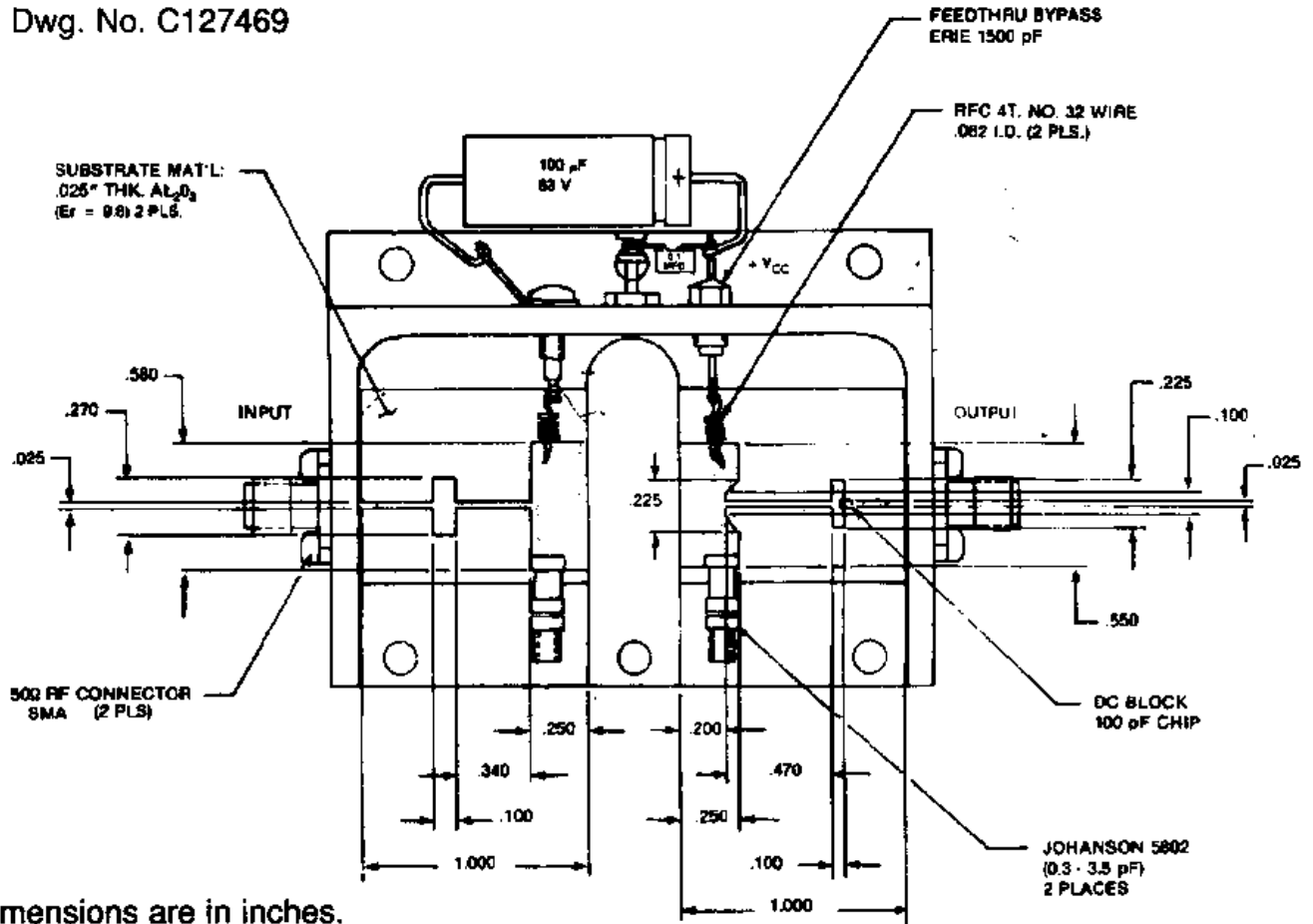

All dimensions are in inches.

PACKAGE MECHANICAL DATA

