



M.S.KENNEDY CORP.

THREE PHASE BRIDGE MOSFET POWER MODULE

3018

4707 Dey Road Liverpool, N.Y. 13088

(315) 701-6751

FEATURES:

- Designed for Higher Current, Bottom Side Braking
- Pin Compatible with MPM3003
- P and N Channel MOSFETs for Ease of Drive
- Isolated Package for Direct Heat Sinking, Excellent Thermal Conductivity
- Avalanche Rated Devices
- Interfaces Directly with Most Brushless Motor Drive IC's
- 55 Volt, 10 Amp P-Channel, 30 Amp N-Channel

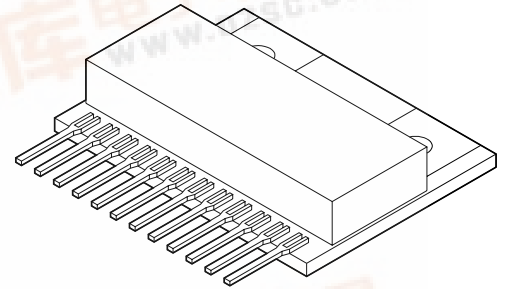

DESCRIPTION:

The MSK 3018 is a three phase bridge power circuit packaged in a space efficient isolated ceramic tab power SIP package. Consisting of P-Channel MOSFETs for the top transistors and N-Channel MOSFETs for the bottom transistors, the MSK 3018 will interface directly with most brushless motor drive IC's without special gate driving requirements. The MSK 3018 uses M.S.Kennedy's proven power hybrid technology to bring a cost effective high performance circuit for use in today's sophisticated servo motor and disk drive systems. The MSK 3018 is a replacement for the MPM3003 with higher current capability when turning on all the N-Channel FETs for braking.

EQUIVALENT SCHEMATIC

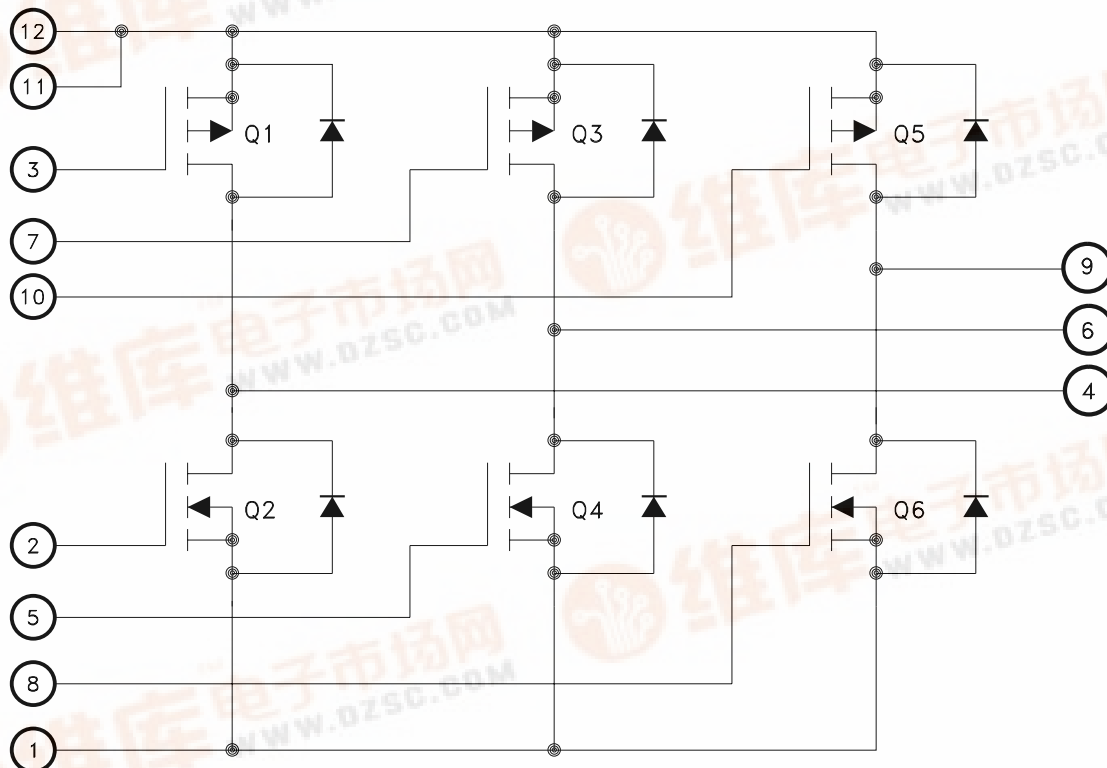

TYPICAL APPLICATIONS

- Three Phase Brushless DC Motor Servo Control
- Disk Drive Spindle Control
- Fin Actuator Control
- Az-El Antenna Control

PIN-OUT INFORMATION

- | | |
|----------------|-----------------|
| 1 Source 2,4,6 | 12 Source 1,3,5 |
| 2 Gate 2 | 11 Source 1,3,5 |
| 3 Gate 1 | 10 Gate 5 |
| 4 Drain 1,2 | 9 Drain 5,6 |
| 5 Gate 4 | 8 Gate 6 |
| 6 Drain 3,4 | 7 Gate 3 |



ABSOLUTE MAXIMUM RATINGS

V _{DSS}	Drain to Source Voltage	55V MAX			
V _{DGDR}	Drain to Gate Voltage (R _{GS} = 1MΩ)	55V MAX			Single Pulse Avalanche Energy (Q2,Q4,Q6) 570mJ (Q1,Q3,Q5) 180mJ
V _{GS}	Gate to Source Voltage (Continuous)	±20V MAX	T _J	Junction Temperature	+175°C MAX
I _D	Continuous Current (N-Channel)	30A MAX	T _{ST}	Storage Temperature	-55°C to +150°C
	(P-Channel)	14A MAX	T _C	Case Operating Temperature Range	-55°C to +125°C
I _{DM}	Pulsed Current (N-Channel)	40A MAX	T _{LD}	Lead Temperature Range (10 Seconds)	300°C MAX
	(P-Channel)	20A MAX			
R _{TH-JC}	Thermal Resistance (Junction to Case) (N-Channel FETs)	2°C/W			
	(P-Channel FETs)	6°C/W			

ELECTRICAL SPECIFICATIONS

Parameter	Test Conditions ④	MSK3018			Units
		Min.	Typ.	Max.	
Drain-Source Breakdown Voltage	V _{GS} = 0 I _D = 0.25mA (All Transistors)	55	-	-	V
Drain-Source Leakage Current	V _{DS} = 55V V _{GS} = 0V (Q2,Q4,Q6)	-	-	25	μA
	V _{DS} = -55V V _{GS} = 0V (Q1,Q3,Q5)	-	-	-25	μA
Gate-Source Leakage Current	V _{GS} = ±20V V _{DS} = 0 (All Transistors)	-	-	±100	nA
Gate-Source Threshold Voltage	V _{DS} = V _{GS} I _D = 250μA (Q2,Q4,Q6)	2.0	-	4.5	V
	V _{DS} = V _{GS} I _D = 250μA (Q1,Q3,Q5)	-2.0	-	-4.5	V
Drain-Source On Resistance ② ⑤	V _{GS} = 10V I _D = 10A (Q2,Q4,Q6)	-	-	0.04	Ω
	V _{GS} = -10V I _D = -10A (Q1,Q3,Q5)	-	-	0.16	Ω
Drain-Source On Resistance ③	V _{GS} = 10V I _D = 10A (Q2,Q4,Q6)	-	-	0.013	Ω
	V _{GS} = 10V I _D = -10A (Q1,Q3,Q5)	-	-	0.10	Ω
Forward Transconductance ①	V _{DS} = 25V I _D = 10A (Q2,Q4,Q6)	30	-	-	S
	V _{DS} = -25V I _D = -10A (Q1,Q3,Q5)	4.2	-	-	S
N-Channel (Q2,Q4,Q6)					
Total Gate Charge ①	I _D = 30A	-	-	150	nC
Gate-Source Charge ①	V _{DS} = 44V	-	-	24	nC
Gate-Drain Charge ①	V _{GS} = 10V	-	-	55	nC
Turn-On Delay Time ①	V _{DD} = 28V	-	14	-	nS
Rise Time ①	I _D = 30A	-	62	-	nS
Turn-Off Delay Time ①	R _G = 2.5Ω	-	47	-	nS
Fall Time ①	R _D = 0.93Ω	-	58	-	nS
Input Capacitance ①	V _{GS} = 0V	-	3400	-	pF
Output Capacitance ①	V _{DS} = 25V	-	830	-	pF
Reverse Transfer Capacitance ①	f = 1MHz	-	240	-	pF
P-CHANNEL (Q1,Q3,Q5)					
Total Gate Charge ①	I _D = -10A	-	-	35	nC
Gate-Source Charge ①	V _{DS} = -44V	-	-	7.9	nC
Gate-Drain Charge ①	V _{GS} = -10V	-	-	16	nC
Turn-On Delay Time ①	V _{DD} = -28V	-	13	-	nS
Rise Time ①	I _D = -10A	-	55	-	nS
Turn-Off Delay Time ①	R _G = 13Ω	-	130	-	nS
Fall Time ①	R _D = 2.6Ω	-	41	-	nS
Input Capacitance ①	V _{GS} = 0V	-	620	-	pF
Output Capacitance ①	V _{DS} = -25V	-	280	-	pF
Reverse Transfer Capacitance ①	f = 1MHz	-	140	-	pF
BODY DIODE					
Forward On Voltage ①	I _S = 30A V _{GS} = 0V (Q2,Q4,Q6)	-	1.3	-	V
	I _S = -10A V _{GS} = 0V (Q1,Q3,Q5)	-	-1.6	-	V
Reverse Recovery Time ①	I _S = 30A di/dt = 100A/μS (Q2,Q4,Q6)	-	120	190	nS
	I _S = -10A di/dt = 100A/μS (Q1,Q3,Q5)	-	54	82	nS
Reverse Recovery Charge ①	I _S = 30A di/dt = 100A/μS (Q2,Q4,Q6)	-	510	760	nC
	I _S = -10A di/dt = 100A/μS (Q1,Q3,Q5)	-	110	160	nC

NOTES:

- ① This parameter is guaranteed by design but need not be tested. Typical parameters are representative of actual device performance but are for reference only.
- ② Resistance as seen at package pins.
- ③ Resistance for die only; use for thermal calculations.

APPLICATION NOTES

N-CHANNEL GATES (Q2, Q4, Q6)

For driving the N-Channel gates, it is important to keep in mind that it is essentially like driving a capacitance to a sufficient voltage to get the channel fully on. Driving the gates to +15 volts with respect to their sources assures that the transistors are on. This will keep the dissipation down to a minimum level [$R_{DS(ON)}$ specified in the data sheet]. How quickly the gate gets turned ON and OFF will determine the dissipation of the transistor while it is transitioning from OFF to ON, and vice-versa. Turning the gate ON and OFF too slow will cause excessive dissipation, while turning it ON and OFF too fast will cause excessive switching noise in the system. It is important to have as low a driving impedance as practical for the size of the transistor. Many motor drive IC's have sufficient gate drive capability for the MSK 3018. If not, paralleled CMOS standard gates will usually be sufficient. A series resistor in the gate circuit slows it down, but also suppresses any ringing caused by stray inductances in the MOSFET circuit. The selection of the resistor is determined by how fast the MOSFET wants to be switched. See Figure 1 for circuit details.

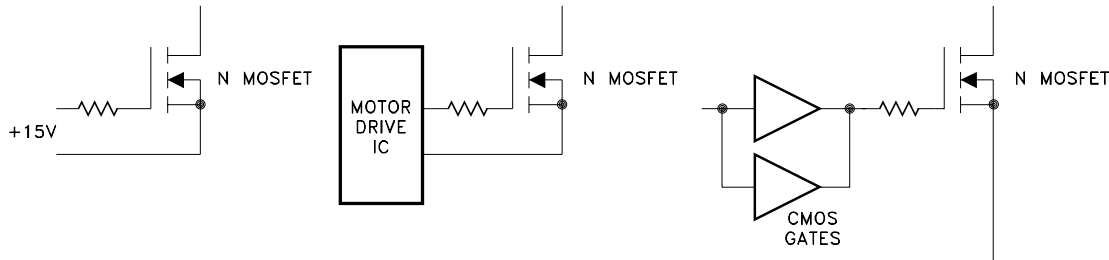

Figure 1

P-CHANNEL GATES (Q1, Q3, Q5)

Most everything applies to driving the P-Channel gates as the N-Channel gates. The only difference is that the P-Channel gate to source voltage needs to be negative. Most motor drive IC's are set up with an open collector or drain output for directly interfacing with the P-channel gates. If not, an external common emitter switching transistor configuration (see Figure 2) will turn the P-Channel MOSFET on. All the other rules of MOSFET gate drive apply here. For high supply voltages, additional circuitry must be used to protect the P-Channel gate from excessive voltages.

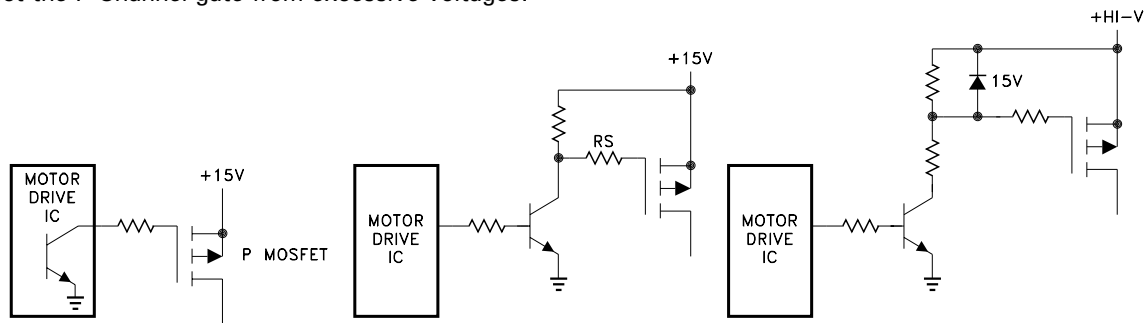

Figure 2

BRIDGE DRIVE CONSIDERATIONS

It is important that the logic used to turn ON and OFF the various transistors allow sufficient "dead time" between a high side transistor and its low side transistor to make sure that at no time are they both ON. When they are, this is called "shoot-through", and it places a momentary short across the power supply. This overly stresses the transistors and causes excessive noise as well. See Figure 3.

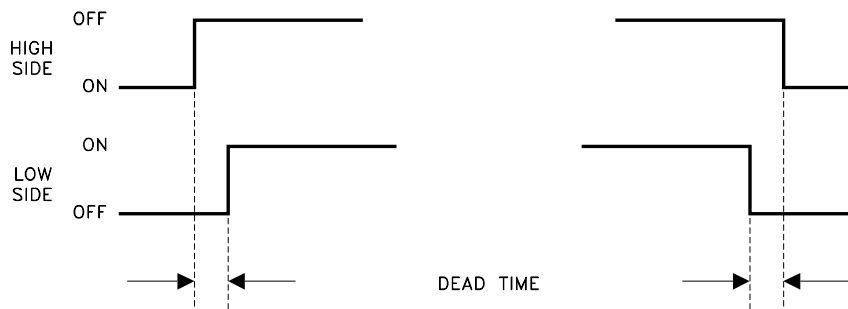

Figure 3

This deadtime should allow for the turn on and turn off time of the transistors, especially when slowing them down with gate resistors. This situation will be present when switching motor direction, or when sophisticated timing schemes are used for servo systems such as locked antiphase PWM'ing for high bandwidth operation.

TYPICAL PERFORMANCE CURVES

N-CHANNEL DEVICES (Q2,Q4,Q6)

DRAIN CURRENT vs DRAIN TO SOURCE VOLTAGE

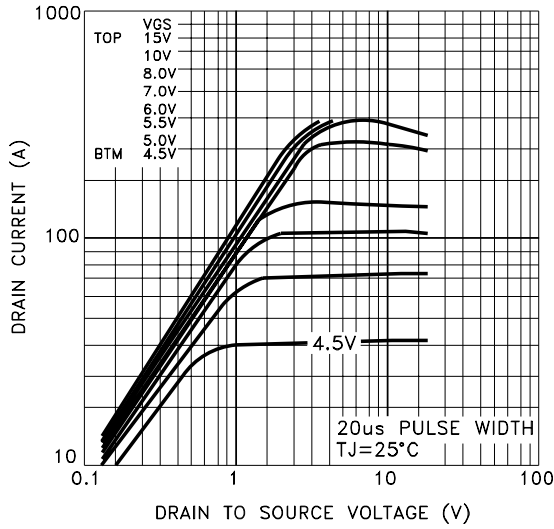

P-CHANNEL DEVICES (Q1,Q3,Q5)

DRAIN CURRENT vs DRAIN TO SOURCE VOLTAGE

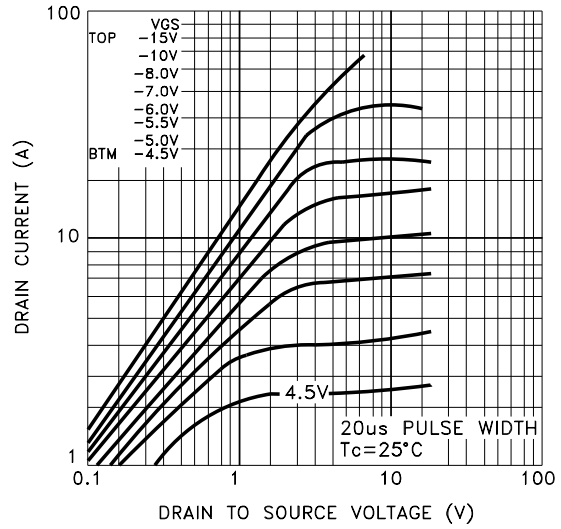

DRAIN CURRENT vs GATE TO SOURCE VOLTAGE

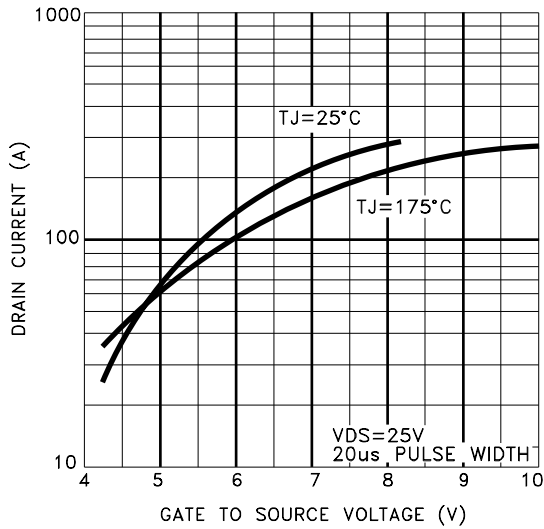

DRAIN CURRENT vs GATE TO SOURCE VOLTAGE

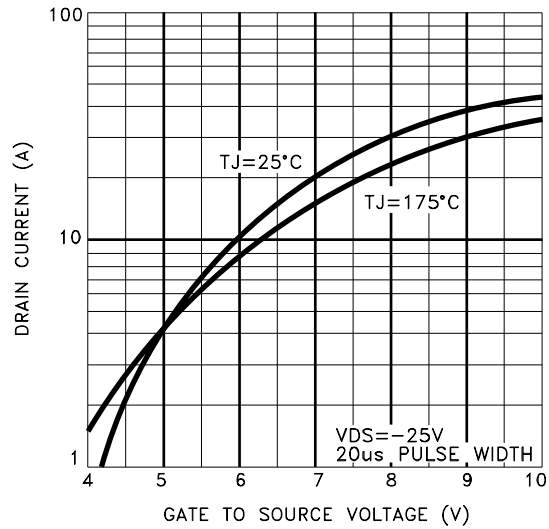

DRAIN TO SOURCE ON RESISTANCE vs JUNCTION TEMP.

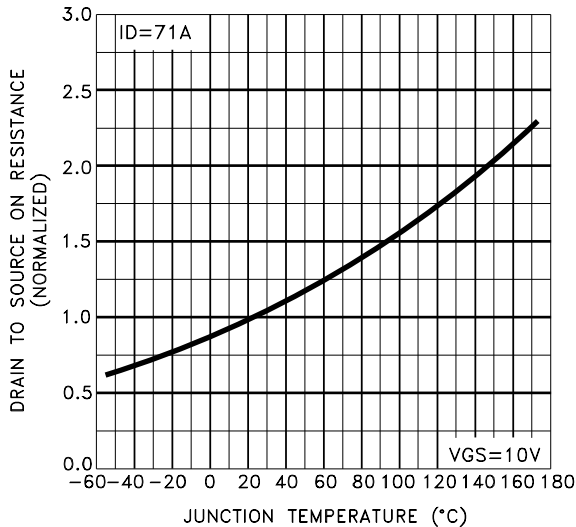

DRAIN TO SOURCE ON RESISTANCE vs JUNCTION TEMP.

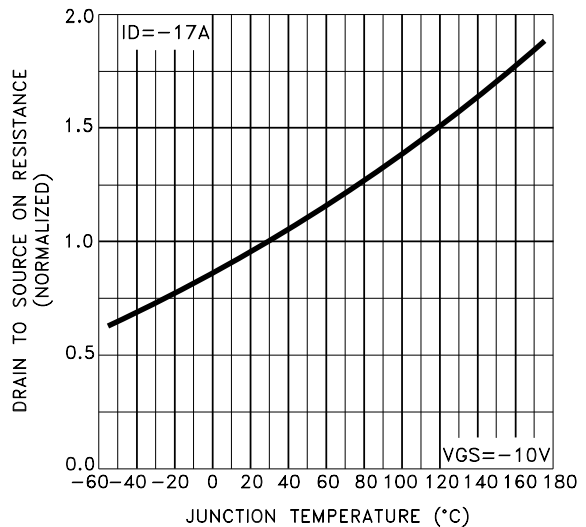

MECHANICAL SPECIFICATIONS

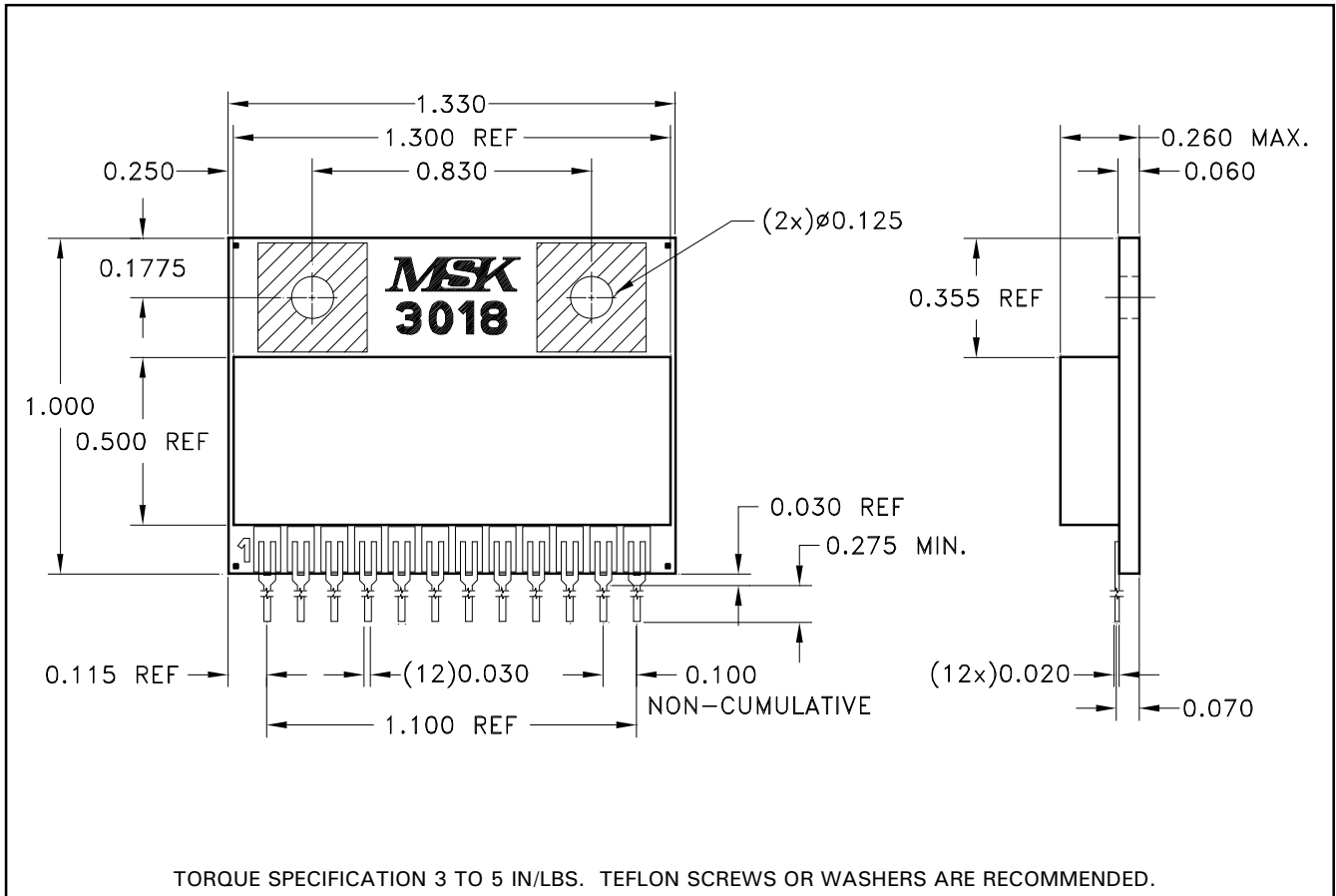

ALL DIMENSIONS ARE ±0.010 INCHES UNLESS OTHERWISE LABELED.

ORDERING INFORMATION

PART NUMBER	SCREENING LEVEL
MSK 3018	Industrial

M.S. Kennedy Corp.
 4707 Dey Road, Liverpool, New York 13088
 Phone (315) 701-6751
 FAX (315) 701-6752
www.mskennedy.com