



10 AMP, 75V, 3 PHASE MOSFET BRIDGE WITH INTELLIGENT INTEGRATED GATE DRIVE

4300

4707 Dey Road Liverpool, N.Y. 13088

(315) 701-6751

FEATURES:

- 75 Volt Motor Supply Voltage
- 10 Amp Output Switch Capability, All N-Channel MOSFET Output Bridge
- 100% Duty Cycle High Side Conduction Capable
- Suitable for PWM Applications from DC to 100KHz
- Shoot-Through/Cross Conduction Protection
- Undervoltage Lockout Protection
- Programmable Dead-Time Control
- Low Active Enable for Bridge Shutdown Control
- Isolated Package Design for High Voltage Isolation Plus Good Thermal Transfer
- Available with Three Lead Bend Options

MIL-PRF-38534 QUALIFIED

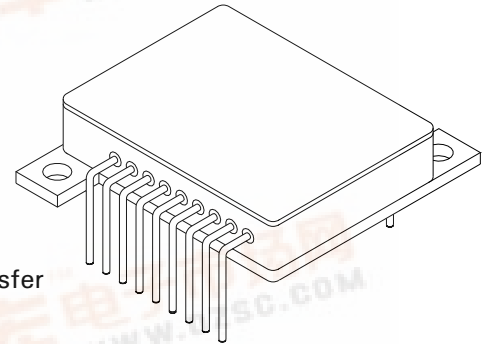

DESCRIPTION:

The MSK 4300 is a 3 phase MOSFET bridge plus drivers in a convenient isolated hermetic package. The hybrid is capable of 10 amps of output current and 75 volts of DC bus voltage. It has a full line of protection features, including undervoltage lockout protection of the bias voltage, cross conduction control and a user programmable dead-time control for shoot-through elimination. In addition, the bridge may be shut down by using the EN (enable) control. The MSK 4300 provides good thermal conductivity for the MOSFETs due to the electrically isolated package design that allows direct heat sinking of the device without insulators.

EQUIVALENT SCHEMATIC

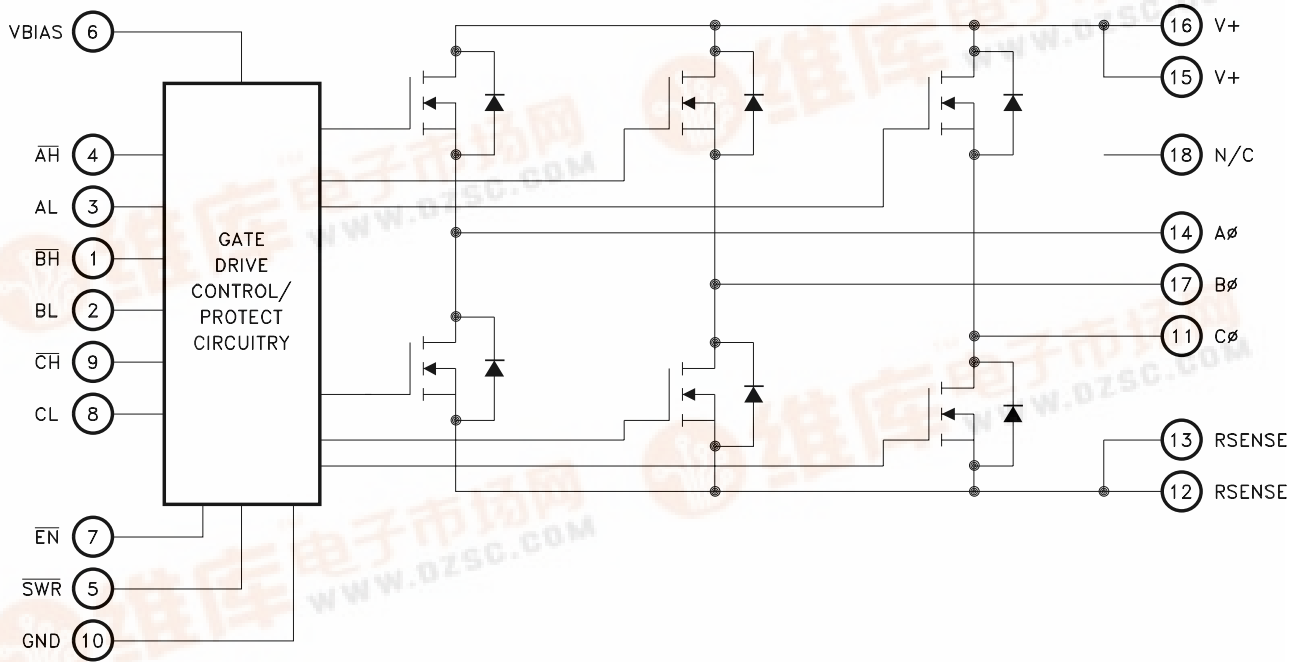

TYPICAL APPLICATIONS

- 3 Phase Brushless DC Servo Control
- 3 Phase AC Induction Motor Control
- Film Actuator Control
- HVAC Blower Control
- Gimbal Control



ABSOLUTE MAXIMUM RATINGS

V ₊	High Voltage Supply	75V
V _{BIAS}	Bias Supply	16V
V _{IND}	Logic Input Voltages	-0.3V to V _{BIAS} + 0.3V
I _{OUT}	Continuous Output Current	10A
I _{PK}	Peak Output Current	25A

θ _{JC}	Thermal Resistance	9°C/W
T _{ST}	Storage Temperature Range	-65°C to +150°C
T _{LD}	Lead Temperature Range (10 Seconds)	+300°C
T _C	Case Operating Temperature	-55°C to +125°C
T _J	Junction Temperature	+150°C

ELECTRICAL SPECIFICATIONS

Parameter	Test Conditions	Group A ^④ Subgroup	MSK 4300H ^③			MSK 4300 ^②			Units
			Min.	Typ.	Max.	Min.	Typ.	Max.	
CONTROL SECTION									
V _{BIAS} Quiescent Current	All Inputs Off	1,2,3		2.5	8		2.5	8	mAmp
V _{BIAS} Operating Current	f = 20KHz, 50% Duty Cycle	1,2,3		12.5	15		12.5	15	mAmp
Undervoltage Threshold (Falling)		1	5.75	6.6	7.5	5.75	6.6	7.5	Volts
Undervoltage Threshold (Rising)		1	6.2	7.1	8.0	6.2	7.1	8.0	Volts
Low Level Input Voltage ^①		-	-	-	0.8	-	-	0.8	Volts
High Level Input Voltage ^①		-	2.7	-	-	2.7	-	-	Volts
Low Level Input Current ^①	V _{IN} = 0V	-	60	100	135	60	100	135	μAmp
High Level Input Current ^①	V _{IN} = 5V	-	-1	-	+1	-1	-	+1	μAmp
OUTPUT BRIDGE									
Drain-Source Breakdown Voltage ^①	I _D = 25μA, All Inputs Off	-	70	-	-	70	-	-	V
Drain-Source Leakage Current ^①	V _{DS} = 70V	-	-	-	25	-	-	25	μAmp
Drain-Source On Resistance (Each FET)	I _D = 10A	1	-	-	0.300	-	-	0.300	Ω
Drain-Source On Resistance ^① (Each FET, For Thermal Calculations Only)		-	-	-	0.16	-	-	0.16	Ω
SWITCHING CHARACTERISTICS									
Rise Time ^①	V ₊ = 30V, R _L = 3Ω I _D = 10A	-	-	5	-	-	5	-	nSec
Fall Time ^①		-	-	6	-	-	6	-	nSec
Turn-On Prop Delay (Lower)	$\overline{\text{SWR}}$ Resistor = ∞	4	-	0.5	2	-	0.5	3	μSec
Turn-Off Prop Delay (Lower)	$\overline{\text{SWR}}$ Resistor = ∞	4	-	5	8	-	5	10	μSec
Turn-On Prop Delay (Upper)	$\overline{\text{SWR}}$ Resistor = ∞	4	-	5	8	-	5	10	μSec
Turn-Off Prop Delay (Upper)	$\overline{\text{SWR}}$ Resistor = ∞	4	-	0.5	2	-	0.5	3	μSec
Dead Time	$\overline{\text{SWR}}$ = ∞	4	6.0	7.0	8.0	6.0	7.0	8.0	μSec
Dead Time	$\overline{\text{SWR}}$ = 12K	4	0.3	0.5	0.7	0.3	0.5	0.7	μSec
SOURCE-DRAIN DIODE CHARACTERISTICS									
Forward Voltage ^①	I _{SD} = 10A	-	-	1.05	1.25	-	1.05	1.25	Volts
Reverse Recovery Time ^①	I _{SD} = 10A, di/dt = 100A/μS	-	-	75	-	-	75	-	nSec

NOTES:

- ① Guaranteed by design but not tested. Typical parameters are representative of actual device performance but are for reference only.
- ② Industrial grade devices shall be tested to subgroups 1 and 4 unless otherwise specified.
- ③ Military grade devices ("H" Suffix) shall be 100% tested to Subgroups 1, 2, 3 and 4.
- ④ Subgroups 5 and 6 testing available upon request.
- ⑤ Subgroup 1, 4 T_A = T_C = +25°C
2, 5 T_A = T_C = +125°C
3, 6 T_A = T_C = -55°C

APPLICATION NOTES

MSK 4300 PIN DESCRIPTIONS

AL, BL, CL - Are the lowside logic level digital inputs. These three inputs control the three lowside bridge transistors. If the highside inputs are low, then the lowside inputs will control both the lowside and the highside of the bridge, with deadtime set by the $\overline{\text{SWR}}$ resistor. $\overline{\text{EN}}$ will override these inputs, forcing all outputs low. These inputs can be driven by logic up to 15V (less than VBIAS). An internal pullup to VBIAS will hold each input high if the pins are not driven.

AH, BH, CH - Are the highside logic level digital inputs. These three inputs control the three highside bridge transistors. Unless the deadtime is disabled by connecting $\overline{\text{SWR}}$ to ground, the lowside input of each phase will override the corresponding highside input. If $\overline{\text{SWR}}$ is the lowside input of each phase will override the corresponding highside input. In this condition, tied to ground, deadtime is disabled and the outputs follow the inputs. In this condition, shoot-through must be avoided externally. $\overline{\text{EN}}$ will override all inputs, forcing outputs low.

VBIAS - Is the positive supply for the gate drive. This pin should be decoupled to ground with at least a 10 μF capacitor.

GROUND - Is the return for the VBIAS supply. This pin should be connected to the return of the lowside MOSFETs or the bottom of the sense resistor at the bottom of the bridge. The gate drive current must return through this pin, so trace lengths should be kept to a minimum. All grounds should be returned to the bottom of the bridge or sense resistor in a star fashion. This will eliminate ground loops.

$\overline{\text{SWR}}$ - Is the pin for controlling the deadtime between the top and bottom transistors of the bridge. By connecting a pullup resistor between this pin and VBIAS, various deadtimes can be obtained. There is an internal 100K Ω pullup resistor connected internally. By adding additional resistors in parallel externally, reduced deadtimes can be achieved. By connecting this pin to ground, all deadtime is eliminated. However, care must be taken to assure that deadtime is being generated by the logic circuitry driving the inputs. Shoot-through can occur (both the top and bottom transistors on at the same time for a given phase, causing a short on the V+ supply to ground) destroying the bridge.

V+ - Is the power connection for the top of the output bridge. This pin must be bypassed by a capacitor to ground of at least 10 μF per amp of output current minimum, and high quality high frequency bypass capacitance to help suppress switching noise.

A0, B0, C0 - Are the output pins for the three phases of the power bridge.

$\overline{\text{EN}}$ - Is the enabling input for the bridge. This digital input, when pulled low, will enable the bridge, following the inputs from AL, BL, CL and AH, BH, CH inputs. When pulled high, it will override all other inputs and disable the bridge. It is internally pulled high to VBIAS, and can be driven by logic levels up to VBIAS.

RSENSE - Are the connections to the bottom of the bridge. All power flowing through the bridge will flow through this point, and can be sensed by connecting a sense resistor from here to ground. The sense resistor will develop a voltage proportional to the current flowing. Size the value and power rating of the sense resistor according to the voltage necessary. 3 volts is the maximum voltage between this point and ground, or damage to the hybrid will result.

BUS VOLTAGE FILTER CAPACITORS

The size and placement of the capacitors for the main voltage bus for the motor will have an effect on the noise filtered throughout the rest of the system. Series RLC tuned circuit is being created by the inductance of the wire (about 30nH per inch), the filter capacitance, and all of the resistances (wire resistance and the capacitor ESR) of the overall power circuit. Voltage spikes from the back EMF if the motor ride on top of the bus voltage. All of this must be taken into account when laying out the system. A first capacitor of high quality and low ESR should be placed as close to the hybrid circuit as possible. Along with that, a capacitor of 5x to 10x the first value should be added (and that second capacitor should have some ESR) and/or a resistor should be added to help with the damping of the voltage spikes. Be careful of the ripple current in all the capacitors. Excessive ripple current, beyond what the capacitor is rated for, will destroy the capacitor.

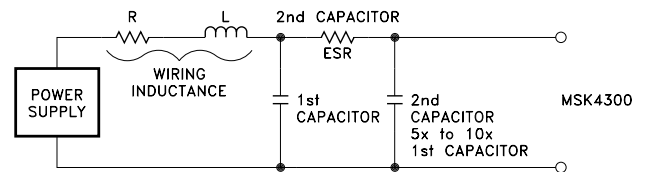

BIAS SUPPLY BYPASS CAPACITORS

It is recommended that at least 10 μF of capacitance for bypassing the VBIAS voltage that supplies the drive circuitry for the MSK 4300, along with 0.1 μF for helping the high frequency current pulses needed by the gate driver. If an extremely long risetime is exhibited by the turn on of the FETs, the extra high frequency capacitance will help.

GENERAL LAYOUT

Good high frequency PC layout techniques are a must. Traces wide enough for the current delivered, and placement of the big capacitors close to the MSK 4300 are very important. The path for the RSENSE connection through any sense resistor back to the GND pins must be as short as possible. This path is the gate drive current path for all the FETs on the lower half of each phase. A short, low inductance path will aid in the switching time of those FETs.

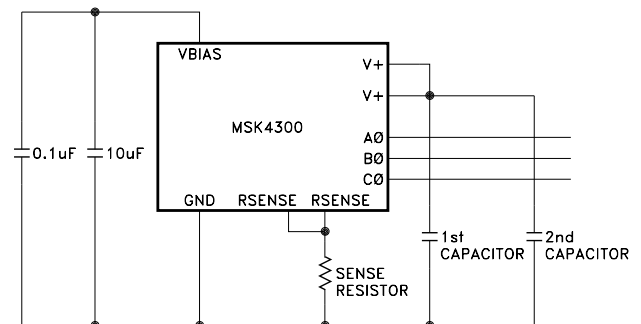

LOW POWER STARTUP

When starting up the circuit utilizing the MSK 4300 for the first time, it is very important to keep certain things in mind. Because of the small size of the bridge, there is no internal short circuit protection and a short circuit will destroy the bridge. Any required short circuit protection must be built outside the bridge. Current and voltage limit the power supply feeding the V+ pins to the bridge, and monitor the current for any signs of short circuiting, or shoot-through currents. If there are large current spikes at the beginning of each switching cycle, there may be shoot through. Try raising the resistor value of the $\overline{\text{SWR}}$. This will lengthen the deadtime and stop shoot-through.

TYPICAL APPLICATION SCHEMATIC

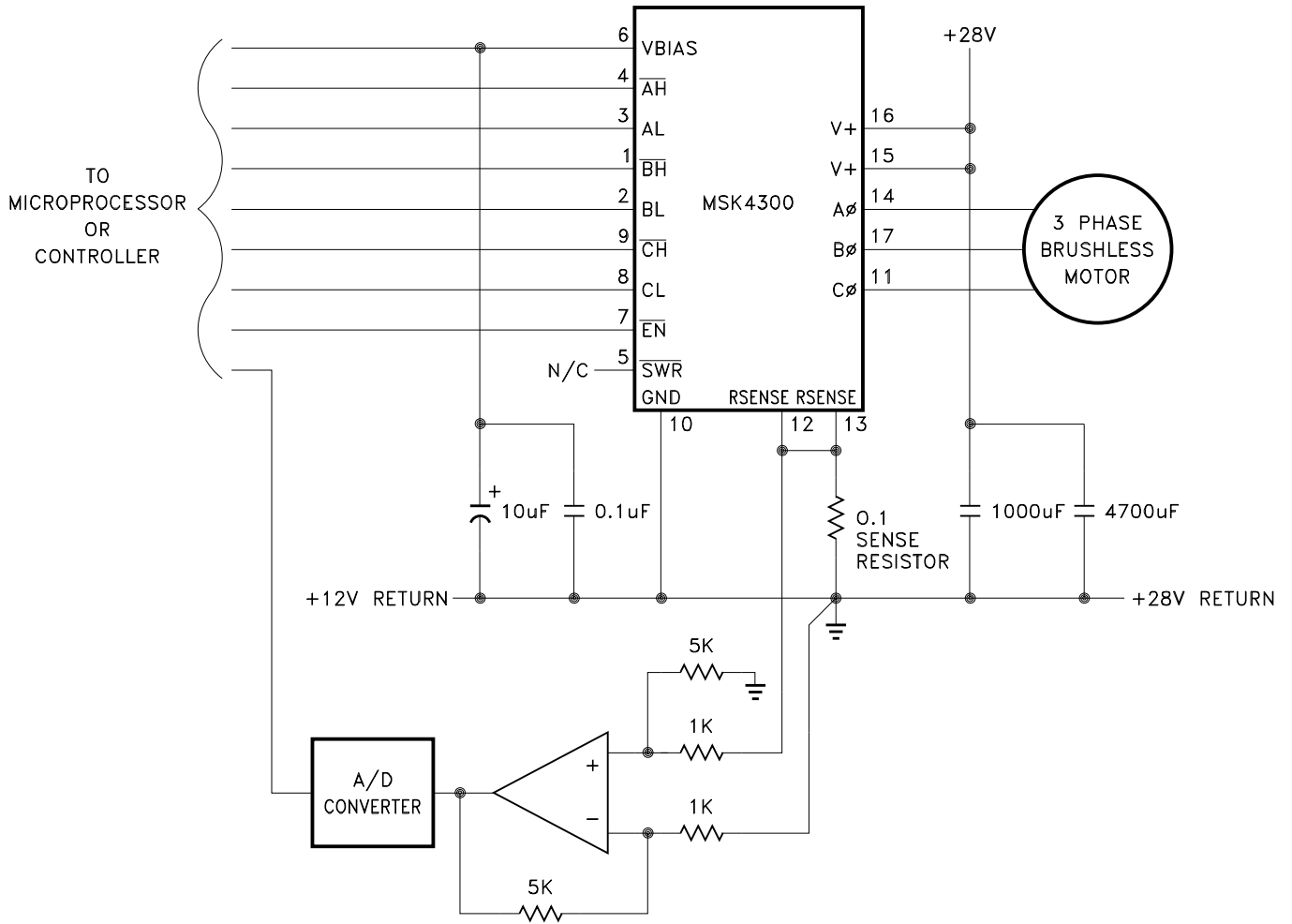

TYPICAL PERFORMANCE CURVES

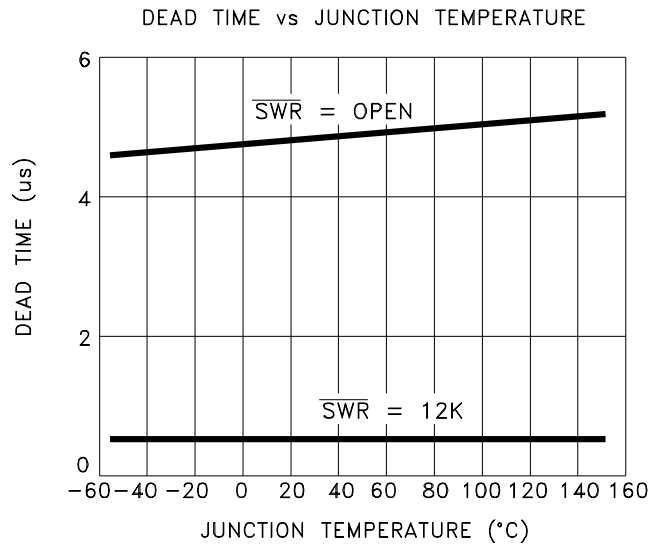
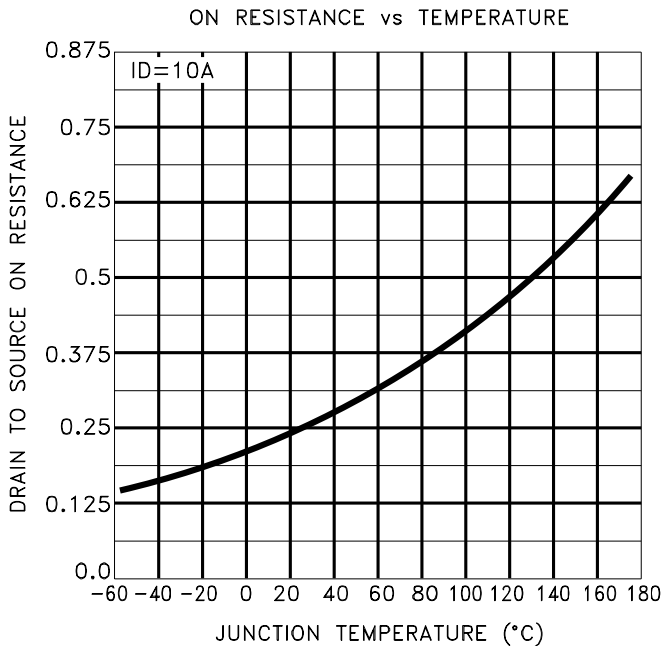

MECHANICAL SPECIFICATIONS

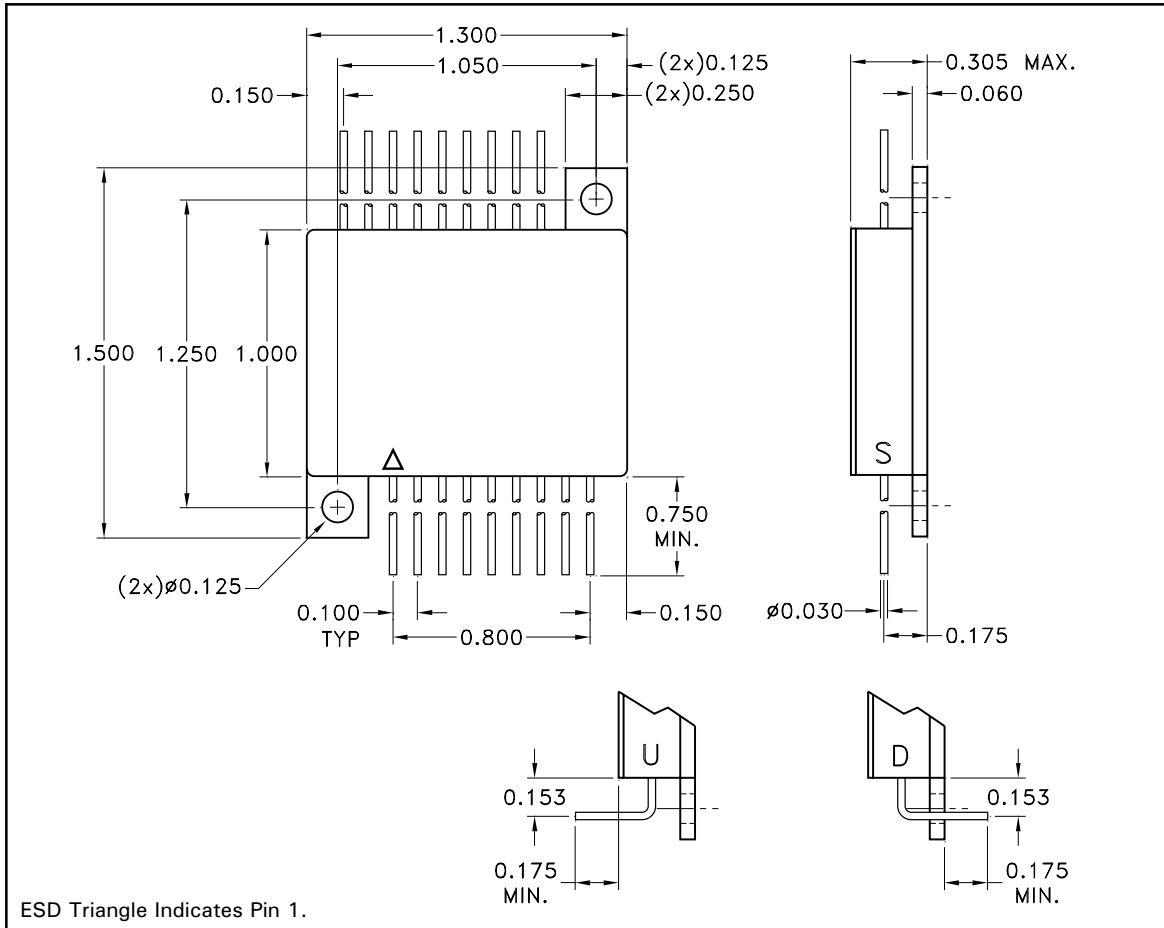

NOTE: ALL DIMENSIONS ARE $\pm .010$ INCHES UNLESS OTHERWISE LABELED.

ORDERING INFORMATION

MSK4300 H U

LEAD CONFIGURATIONS

S = STRAIGHT; U = BENT UP; D = BENT DOWN

SCREENING

BLANK = INDUSTRIAL; H = MIL-PRF-38534

GENERAL PART NUMBER

The above example is a Military grade hybrid with leads bent up.

M.S. Kennedy Corp.
 4707 Dey Road, Liverpool, New York 13088
 Phone (315) 701-6751
 FAX (315) 701-6752
 www.mskennedy.com