

- **Low Supply-Voltage Range, 1.8 V to 3.6 V**
- **Ultralow-Power Consumption:**
 - Active Mode: 160 μ A at 1 MHz, 2.2 V
 - Standby Mode: 0.9 μ A
 - Off Mode (RAM Retention) : 0.1 μ A
- **Five Power-Saving Modes**
- **Wake-Up From Standby Mode in less than 6 μ s**
- **16-Bit RISC Architecture, 125-ns Instruction Cycle Time**
- **16-Bit Timer_B With Three Capture/Compare-With-Shadow Registers**
- **16-Bit Timer_A With Three Capture/Compare Registers**
- **On-Chip Comparator**
- **Serial Communication Interface (USART), Software Selects Asynchronous UART or Synchronous SPI**
- **Programmable Code Protection With Security Fuse**
- **Family Members Include:**
 - MSP430C1331: 8KB ROM, 256B RAM
 - MSP430C1351: 16KB ROM, 512B RAM
- **Available in 64-Pin Quad Flat Pack (QFP)**
- **Emulation: Use MSP430F13xIPM**
- **For Complete Module Descriptions, See the *MSP430x1xx Family User's Guide*, Literature Number SLAU049**

description

The Texas Instruments MSP430 family of ultralow-power microcontrollers consist of several devices featuring different sets of peripherals targeted for various applications. The architecture, combined with five low power modes is optimized to achieve extended battery life in portable measurement applications. The device features a powerful 16-bit RISC CPU, 16-bit registers, and constant generators that attribute to maximum code efficiency. The digitally controlled oscillator (DCO) allows wake-up from low-power modes to active mode in less than 6 μ s.

The MSP430C13x1 is a microcontroller configuration with two built-in 16-bit timers, one universal serial synchronous/asynchronous communication interfaces (USART), and 48 I/O pins.

Typical applications include sensor systems that capture analog signals, convert them to digital values, and process and transmit the data to a host system. The timers make the configurations ideal for industrial control applications, hand-held meters, etc.

AVAILABLE OPTIONS

T _A	PACKAGED DEVICES
	PLASTIC 64-PIN QFP (PM)
-40°C to 85°C	MSP430C1331IPM MSP430C1351IPM

Please be aware that an important notice concerning availability, standard warranty, and use in critical applications of Texas Instruments semiconductor products and disclaimers thereto appears at the end of this data sheet.

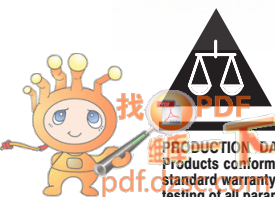

MSP430C13x1 MIXED SIGNAL MICROCONTROLLER

SLAS341B – SEPTEMBER 2001 – REVISED SEPTEMBER 2004

pin designation, MSP430C1331, MSP430C1351

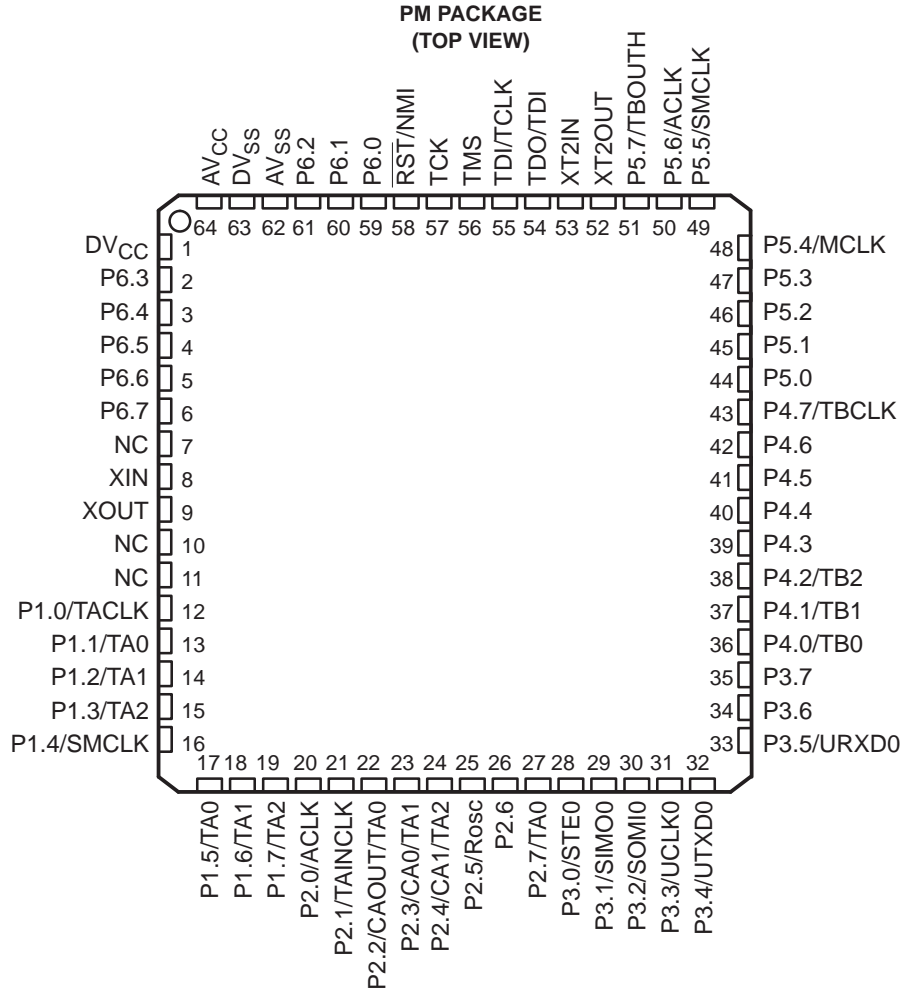

NC – No internal connection

MSP430C13x1 MIXED SIGNAL MICROCONTROLLER

SLAS341B – SEPTEMBER 2001 – REVISED SEPTEMBER 2004

functional block diagrams

MSP430C13x1

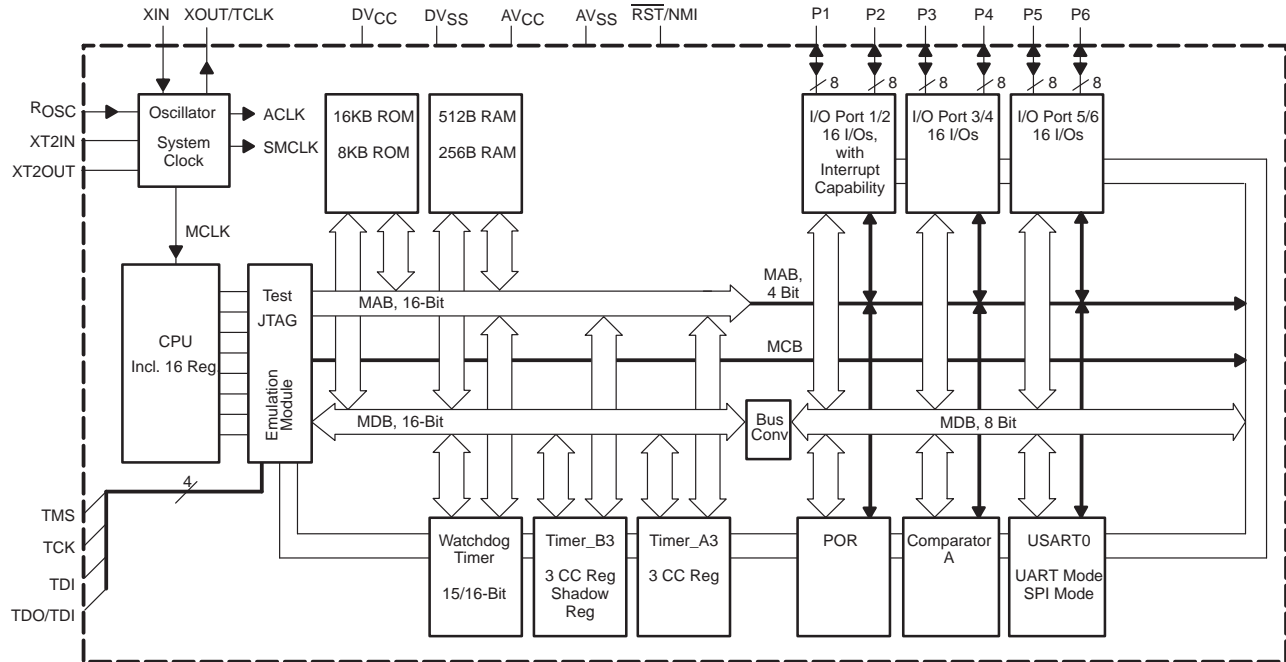

Terminal Functions

TERMINAL NAME	NO.	I/O	DESCRIPTION
AVCC	64		Supply voltage, positive terminal. AVCC and DVCC are internally connected together.
AVSS	62		Supply voltage, negative terminal. AVSS and DVSS are internally connected together.
DVCC	1		Supply voltage, positive terminal. AVCC and DVCC are internally connected together.
DVSS	63		Supply voltage, negative terminal. AVSS and DVSS are internally connected together.
P1.0/TACLK	12	I/O	General-purpose digital I/O pin/Timer_A, clock signal TACLK input
P1.1/TA0	13	I/O	General-purpose digital I/O pin/Timer_A, capture: CCI0A input, compare: Out0 output
P1.2/TA1	14	I/O	General-purpose digital I/O pin/Timer_A, capture: CCI1A input, compare: Out1 output
P1.3/TA2	15	I/O	General-purpose digital I/O pin/Timer_A, capture: CCI2A input, compare: Out2 output
P1.4/SMCLK	16	I/O	General-purpose digital I/O pin/SMCLK signal output
P1.5/TA0	17	I/O	General-purpose digital I/O pin/Timer_A, compare: Out0 output
P1.6/TA1	18	I/O	General-purpose digital I/O pin/Timer_A, compare: Out1 output
P1.7/TA2	19	I/O	General-purpose digital I/O pin/Timer_A, compare: Out2 output
P2.0/ACLK	20	I/O	General-purpose digital I/O pin/ACLK output
P2.1/TAINCLK	21	I/O	General-purpose digital I/O pin/Timer_A, clock signal at INCLK
P2.2/CAOUT/TA0	22	I/O	General-purpose digital I/O pin/Timer_A, capture: CCI0B input/Comparator_A output
P2.3/CA0/TA1	23	I/O	General-purpose digital I/O pin/Timer_A, compare: Out1 output/Comparator_A input
P2.4/CA1/TA2	24	I/O	General-purpose digital I/O pin/Timer_A, compare: Out2 output/Comparator_A input
P2.5/ROSC	25	I/O	General-purpose digital I/O pin/input for external resistor defining the DCO nominal frequency
P2.6	26	I/O	General-purpose digital I/O pin
P2.7/TA0	27	I/O	General-purpose digital I/O pin/Timer_A, compare: Out0 output
P3.0/STE0	28	I/O	General-purpose digital I/O pin/slave transmit enable – USART0/SPI mode

MSP430C13x1 MIXED SIGNAL MICROCONTROLLER

SLAS341B – SEPTEMBER 2001 – REVISED SEPTEMBER 2004

Terminal Functions (Continued)

TERMINAL NAME	NO.	I/O	DESCRIPTION
P3.1/SIMO0	29	I/O	General-purpose digital I/O pin/slave in/master out of USART0/SPI mode
P3.2/SOMI0	30	I/O	General-purpose digital I/O pin/slave out/master in of USART0/SPI mode
P3.3/UCLK0	31	I/O	General-purpose digital I/O pin/external clock input – USART0/UART or SPI mode, clock output – USART0/SPI mode
P3.4/UTXD0	32	I/O	General-purpose digital I/O pin/transmit data out – USART0/UART mode
P3.5/URXD0	33	I/O	General-purpose digital I/O pin/receive data in – USART0/UART mode
P3.6	34	I/O	General-purpose digital I/O pin
P3.7	35	I/O	General-purpose digital I/O pin
P4.0/TB0	36	I/O	General-purpose digital I/O pin/Timer_B, capture: CCI0A/B input, compare: Out0 output
P4.1/TB1	37	I/O	General-purpose digital I/O pin/Timer_B, capture: CCI1A/B input, compare: Out0 output
P4.2/TB2	38	I/O	General-purpose digital I/O pin/Timer_B, capture: CCI2A/B input, compare: Out0 output
P4.3	39	I/O	General-purpose digital I/O pin
P4.4	40	I/O	General-purpose digital I/O pin
P4.5	41	I/O	General-purpose digital I/O pin
P4.6	42	I/O	General-purpose digital I/O pin
P4.7/TBCLK	43	I/O	General-purpose digital I/O pin/Timer_B, clock signal TBCLK input
P5.0	44	I/O	General-purpose digital I/O pin
P5.1	45	I/O	General-purpose digital I/O pin
P5.2	46	I/O	General-purpose digital I/O pin
P5.3	47	I/O	General-purpose digital I/O pin
P5.4/MCLK	48	I/O	General-purpose digital I/O pin/main system clock MCLK output
P5.5/SMCLK	49	I/O	General-purpose digital I/O pin/submain system clock SMCLK output
P5.6/ACLK	50	I/O	General-purpose digital I/O pin/auxiliary clock ACLK output
P5.7/TBOUTH	51	I/O	General-purpose digital I/O pin/switch all PWM digital output ports to high impedance – Timer_B7 TB0 to TB2
P6.0	59	I/O	General-purpose digital I/O pin
P6.1	60	I/O	General-purpose digital I/O pin
P6.2	61	I/O	General-purpose digital I/O pin
P6.3	2	I/O	General-purpose digital I/O pin
P6.4	3	I/O	General-purpose digital I/O pin
P6.5	4	I/O	General-purpose digital I/O pin
P6.6	5	I/O	General-purpose digital I/O pin
P6.7	6	I/O	General-purpose digital I/O pin
RST/NMI	58	I	Reset input, nonmaskable interrupt input port
TCK	57	I	Test clock. TCK is the clock input port for device programming test.
TDI/TCLK	55	I	Test data input or test clock input. TDI is used as a data input port. The device protection fuse is connected to TDI.
TDO/TDI	54	I/O	Test data output port. TDO/TDI data output
TMS	56	I	Test mode select. TMS is used as an input port for device test.
NC	7, 10, 11		No internal connection
XIN	8	I	Input port for crystal oscillator XT1. Standard or watch crystals can be connected.
XOUT	9	O	Output terminal of crystal oscillator XT1
XT2IN	53	I	Input port for crystal oscillator XT2. Only standard crystals can be connected.
XT2OUT	52	O	Output terminal of crystal oscillator XT2

short-form description

CPU

The MSP430 CPU has a 16-bit RISC architecture that is highly transparent to the application. All operations, other than program-flow instructions, are performed as register operations in conjunction with seven addressing modes for source operand and four addressing modes for destination operand.

The CPU is integrated with 16 registers that provide reduced instruction execution time. The register-to-register operation execution time is one cycle of the CPU clock.

Four of the registers, R0 to R3, are dedicated as program counter, stack pointer, status register, and constant generator respectively. The remaining registers are general-purpose registers.

Peripherals are connected to the CPU using data, address, and control buses, and can be handled with all instructions.

instruction set

The instruction set consists of 51 instructions with three formats and seven address modes. Each instruction can operate on word and byte data. Table 1 shows examples of the three types of instruction formats; the address modes are listed in Table 2.

Program Counter	PC/R0
Stack Pointer	SP/R1
Status Register	SR/CG1/R2
Constant Generator	CG2/R3
General-Purpose Register	R4
General-Purpose Register	R5
General-Purpose Register	R6
General-Purpose Register	R7
General-Purpose Register	R8
General-Purpose Register	R9
General-Purpose Register	R10
General-Purpose Register	R11
General-Purpose Register	R12
General-Purpose Register	R13
General-Purpose Register	R14
General-Purpose Register	R15

Table 1. Instruction Word Formats

Dual operands, source-destination	e.g. ADD R4,R5	R4 + R5 ----> R5
Single operands, destination only	e.g. CALL R8	PC -->(TOS), R8--> PC
Relative jump, un/conditional	e.g. JNE	Jump-on-equal bit = 0

Table 2. Address Mode Descriptions

ADDRESS MODE	S	D	SYNTAX	EXAMPLE	OPERATION
Register	●	●	MOV Rs,Rd	MOV R10,R11	R10 --> R11
Indexed	●	●	MOV X(Rn),Y(Rm)	MOV 2(R5),6(R6)	M(2+R5)--> M(6+R6)
Symbolic (PC relative)	●	●	MOV EDE,TONI		M(ED E) --> M(TONI)
Absolute	●	●	MOV &MEM,&TCDAT		M(MEM) --> M(TCDAT)
Indirect	●		MOV @Rn,Y(Rm)	MOV @R10,Tab(R6)	M(R10) --> M(Tab+R6)
Indirect autoincrement	●		MOV @Rn+,Rm	MOV @R10+,R11	M(R10) --> R11 R10 + 2--> R10
Immediate	●		MOV #X,TONI	MOV #45,TONI	#45 --> M(TONI)

NOTE: S = source D = destination

MSP430C13x1

MIXED SIGNAL MICROCONTROLLER

SLAS341B – SEPTEMBER 2001 – REVISED SEPTEMBER 2004

operating modes

The MSP430 has one active mode and five software selectable low-power modes of operation. An interrupt event can wake up the device from any of the five low-power modes, service the request and restore back to the low-power mode on return from the interrupt program.

The following six operating modes can be configured by software:

- Active mode AM;
 - All clocks are active
- Low-power mode 0 (LPM0);
 - CPU is disabled
ACLK and SMCLK remain active. MCLK is disabled
- Low-power mode 1 (LPM1);
 - CPU is disabled
ACLK and SMCLK remain active. MCLK is disabled
DCO's dc-generator is disabled if DCO not used in active mode
- Low-power mode 2 (LPM2);
 - CPU is disabled
MCLK and SMCLK are disabled
DCO's dc-generator remains enabled
ACLK remains active
- Low-power mode 3 (LPM3);
 - CPU is disabled
MCLK and SMCLK are disabled
DCO's dc-generator is disabled
ACLK remains active
- Low-power mode 4 (LPM4);
 - CPU is disabled
ACLK is disabled
MCLK and SMCLK are disabled
DCO's dc-generator is disabled
Crystal oscillator is stopped

MSP430C13x1 MIXED SIGNAL MICROCONTROLLER

SLAS341B – SEPTEMBER 2001 – REVISED SEPTEMBER 2004

interrupt vector addresses

The interrupt vectors and the power-up starting address are located in the address range 0FFFFh – 0FFE0h. The vector contains the 16-bit address of the appropriate interrupt-handler instruction sequence.

INTERRUPT SOURCE	INTERRUPT FLAG	SYSTEM INTERRUPT	WORD ADDRESS	PRIORITY
Power-up External reset Watchdog	WDTIFG (see Note 1)	Reset	0FFFEh	15, highest
NMI Oscillator fault	NMIIFG (see Notes 1 & 4) OFIFG (see Notes 1 & 4)	(Non)maskable (Non)maskable	0FFFCh	14
Timer_B3	TBCCR0 CCIFG (see Note 2)	Maskable	0FFFAh	13
Timer_B3	TBCCR1 and TBCCR2 CCIFGs, TBIFG (see Notes 1 & 2)	Maskable	0FFF8h	12
Comparator_A	CAIFG	Maskable	0FFF6h	11
Watchdog timer	WDTIFG	Maskable	0FFF4h	10
USART0 receive	URXIFG0	Maskable	0FFF2h	9
USART0 transmit	UTXIFG0	Maskable	0FFF0h	8
			0FFEEh	7
Timer_A3	TACCR0 CCIFG (see Note 2)	Maskable	0FFECCh	6
Timer_A3	TACCR1 and TACCR2 CCIFGs, TAIFG (see Notes 1 & 2)	Maskable	0FFEAh	5
I/O port P1 (eight flags)	P1IFG.0 to P1IFG.7 (see Notes 1 & 2)	Maskable	0FFE8h	4
			0FFE6h	3
			0FFE4h	2
I/O port P2 (eight flags)	P2IFG.0 to P2IFG.7 (see Notes 1 & 2)	Maskable	0FFE2h	1
			0FFE0h	0, lowest

- NOTES:
1. Multiple source flags
 2. Interrupt flags are located in the module.
 3. Nonmaskable: neither the individual nor the general interrupt-enable bit will disable an interrupt event.
 4. (Non)maskable: the individual interrupt-enable bit can disable an interrupt event, but the general-interrupt enable can not disable it.

MSP430C13x1 MIXED SIGNAL MICROCONTROLLER

SLAS341B – SEPTEMBER 2001 – REVISED SEPTEMBER 2004

special function registers

Most interrupt and module-enable bits are collected in the lowest address space. Special-function register bits not allocated to a functional purpose are not physically present in the device. This arrangement provides simple software access.

interrupt enable 1 and 2

Address	7	6	5	4	3	2	1	0
0h	UTXIE0	URXIE0		NMIIE			OFIE	WDTIE
	rw-0	rw-0		rw-0			rw-0	rw-0

WDTIE: Watchdog Timer interrupt enable. Inactive if watchdog mode is selected. Active if Watchdog Timer is configured in interval timer mode.

OFIE: Oscillator-fault-interrupt enable

NMIIE: Nonmaskable-interrupt enable

URXIE0: USART0: UART and SPI receive-interrupt enable

UTXIE0: USART0: UART and SPI transmit-interrupt enable

Address	7	6	5	4	3	2	1	0
01h								

interrupt flag register 1 and 2

Address	7	6	5	4	3	2	1	0
02h	UTXIFG0	URXIFG0		NMIIFG			OFIFG	WDTIFG
	rw-1	rw-0		rw-0			rw-1	rw-(0)

WDTIFG: Set on Watchdog Timer overflow (in watchdog mode) or security key violation. Reset on V_{CC} power-up or a reset condition at RST/NMI pin in reset mode.

OFIFG: Flag set on oscillator fault

NMIIFG: Set via \overline{RST}/NMI pin

URXIFG0: USART0: UART and SPI receive flag

UTXIFG0: USART0: UART and SPI transmit flag

Address	7	6	5	4	3	2	1	0
03h								

module enable registers 1 and 2

Address	7	6	5	4	3	2	1	0
04h	UTXE0	URXE0 USPIE0						
	rw-0	rw-0						

URXE0: USART0: UART receive enable

UTXE0: USART0: UART transmit enable

USPIE0: USART0: SPI (synchronous peripheral interface) transmit and receive enable

MSP430C13x1 MIXED SIGNAL MICROCONTROLLER

SLAS341B – SEPTEMBER 2001 – REVISED SEPTEMBER 2004

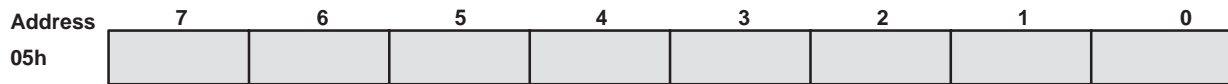

Legend: rw: Bit Can Be Read and Written
 rw-0,1: Bit Can Be Read and Written. It Is Reset or Set by PUC.
 rw-(0,1): Bit Can Be Read and Written. It Is Reset or Set by POR.
□ SFR Bit Not Present in Device

memory organization

		MSP430C1331	MSP430C1351
Memory	Size	8KB	16KB
Interrupt vector	ROM	0FFFFh – 0FFE0h	0FFFFh – 0FFE0h
Code memory	ROM	0FFFFh – 0E000h	0FFFFh – 0C000h
RAM	Size	256 Byte 02FFh – 0200h	512 Byte 03FFh – 0200h
Peripherals	16-bit	01FFh – 0100h	01FFh – 0100h
	8-bit	0FFh – 010h	0FFh – 010h
	8-bit SFR	0Fh – 00h	0Fh – 00h

peripherals

Peripherals are connected to the CPU through data, address, and control busses and can be handled using all instructions. For complete module descriptions, see the *MSP430x1xx Family User's Guide*, literature number SLAU049.

digital I/O

There are six 8-bit I/O ports implemented—ports P1 through P6:

- All individual I/O bits are independently programmable.
- Any combination of input, output, and interrupt conditions is possible.
- Edge-selectable interrupt input capability for all the eight bits of ports P1 and P2.
- Read/write access to port-control registers is supported by all instructions.

oscillator and system clock

The clock system is supported by the basic clock module that includes support for a 32768-Hz watch crystal oscillator, an internal digitally-controlled oscillator (DCO) and a high frequency crystal oscillator. The basic clock module is designed to meet the requirements of both low system cost and low-power consumption. The internal DCO provides a fast turn-on clock source and stabilizes in less than 6 μ s. The basic clock module provides the following clock signals:

- Auxiliary clock (ACLK), sourced from a 32768-Hz watch crystal or a high frequency crystal.
- Main clock (MCLK), the system clock used by the CPU.
- Sub-Main clock (SMCLK), the sub-system clock used by the peripheral modules.

watchdog timer

The primary function of the watchdog timer (WDT) module is to perform a controlled system restart after a software problem occurs. If the selected time interval expires, a system reset is generated. If the watchdog function is not needed in an application, the module can be configured as an interval timer and can generate interrupts at selected time intervals.

MSP430C13x1 MIXED SIGNAL MICROCONTROLLER

SLAS341B – SEPTEMBER 2001 – REVISED SEPTEMBER 2004

USART0

The MSP430C13x1 devices have one hardware universal synchronous/asynchronous receive transmit (USART0) peripheral module that is used for serial data communication. The USART supports synchronous SPI (3 or 4 pin) and asynchronous UART communication protocols, using double-buffered transmit and receive channels.

comparator_A

The primary function of the comparator_A module is to support precision slope analog-to-digital conversions, battery-voltage supervision, and monitoring of external analog signals.

timer_A3

Timer_A3 is a 16-bit timer/counter with three capture/compare registers. Timer_A3 can support multiple capture/compares, PWM outputs, and interval timing. Timer_A3 also has extensive interrupt capabilities. Interrupts may be generated from the counter on overflow conditions and from each of the capture/compare registers.

Timer_A3 Signal Connections					
Input Pin Number	Device Input Signal	Module Input Name	Module Block	Module Output Signal	Output Pin Number
12 - P1.0	TACLK	TACLK	Timer	NA	
	ACLK	ACLK			
	SMCLK	SMCLK			
21 - P2.1	TAINCLK	INCLK			
13 - P1.1	TA0	CCI0A	CCR0	TA0	13 - P1.1
22 - P2.2	TA0	CCI0B			17 - P1.5
	DVSS	GND			27 - P2.7
	DVCC	VCC			
14 - P1.2	TA1	CCI1A	CCR1	TA1	14 - P1.2
	CAOUT (internal)	CCI1B			18 - P1.6
	DVSS	GND			23 - P2.3
	DVCC	VCC			
15 - P1.3	TA2	CCI2A	CCR2	TA2	15 - P1.3
	ACLK (internal)	CCI2B			19 - P1.7
	DVSS	GND			24 - P2.4
	DVCC	VCC			

MSP430C13x1 MIXED SIGNAL MICROCONTROLLER

SLAS341B – SEPTEMBER 2001 – REVISED SEPTEMBER 2004

timer_B3

Timer_B3 is a 16-bit timer/counter with three capture/compare registers. Timer_B3 can support multiple capture/compares, PWM outputs, and interval timing. Timer_B3 also has extensive interrupt capabilities. Interrupts may be generated from the counter on overflow conditions and from each of the capture/compare registers.

Timer_B3 Signal Connections					
Input Pin Number	Device Input Signal	Module Input Name	Module Block	Module Output Signal	Output Pin Number
43 - P4.7	TBCLK	TBCLK	Timer	NA	
	ACLK	ACLK			
	SMCLK	SMCLK			
43 - P4.7	TBCLK	INCLK			
36 - P4.0	TB0	CCI0A	CCR0	TB0	36 - P4.0
36 - P4.0	TB0	CCI0B			
	DVSS	GND			
	DVCC	VCC			
37 - P4.1	TB1	CCI1A	CCR1	TB1	37 - P4.1
37 - P4.1	TB1	CCI1B			
	DVSS	GND			
	DVCC	VCC			
38 - P4.2	TB2	CCI2A	CCR2	TB2	38 - P4.2
38 - P4.2	TB2	CCI2B			
	DVSS	GND			
	DVCC	VCC			

MSP430C13x1 MIXED SIGNAL MICROCONTROLLER

SLAS341B – SEPTEMBER 2001 – REVISED SEPTEMBER 2004

peripheral file map

PERIPHERALS WITH WORD ACCESS			
Watchdog	Watchdog Timer control	WDTCTL	0120h
Timer_B3	Timer_B interrupt vector	TBIV	011Eh
	Timer_B control	TBCTL	0180h
	Capture/compare control 0	TBCCTL0	0182h
	Capture/compare control 1	TBCCTL1	0184h
	Capture/compare control 2	TBCCTL2	0186h
	Reserved		0188h
	Reserved		018Ah
	Reserved		018Ch
	Reserved		018Eh
	Timer_B register	TBR	0190h
	Capture/compare register 0	TBCCR0	0192h
	Capture/compare register 1	TBCCR1	0194h
	Capture/compare register 2	TBCCR2	0196h
	Reserved		0198h
	Reserved		019Ah
	Reserved		019Ch
Reserved		019Eh	
Timer_A3	Timer_A interrupt vector	TAIV	012Eh
	Timer_A control	TACTL	0160h
	Capture/compare control 0	TACCTL0	0162h
	Capture/compare control 1	TACCTL1	0164h
	Capture/compare control 2	TACCTL2	0166h
	Reserved		0168h
	Reserved		016Ah
	Reserved		016Ch
	Reserved		016Eh
	Timer_A register	TAR	0170h
	Capture/compare register 0	TACCR0	0172h
	Capture/compare register 1	TACCR1	0174h
	Capture/compare register 2	TACCR2	0176h
	Reserved		0178h
	Reserved		017Ah
	Reserved		017Ch
Reserved		017Eh	
PERIPHERALS WITH BYTE ACCESS			
USART0	Transmit buffer	U0TXBUF	077h
	Receive buffer	U0RXBUF	076h
	Baud rate	U0BR1	075h
	Baud rate	U0BR0	074h
	Modulation control	U0MCTL	073h
	Receive control	U0RCTL	072h
	Transmit control	U0TCTL	071h
	USART control	U0CTL	070h

MSP430C13x1 MIXED SIGNAL MICROCONTROLLER

SLAS341B – SEPTEMBER 2001 – REVISED SEPTEMBER 2004

peripheral file map (continued)

PERIPHERALS WITH BYTE ACCESS (CONTINUED)			
Comparator_A	Comparator_A port disable	CAPD	05Bh
	Comparator_A control2	CACTL2	05Ah
	Comparator_A control1	CACTL1	059h
Basic Clock	Basic clock system control2	BCSCTL2	058h
	Basic clock system control1	BCSCTL1	057h
	DCO clock frequency control	DCOCTL	056h
Port P6	Port P6 selection	P6SEL	037h
	Port P6 direction	P6DIR	036h
	Port P6 output	P6OUT	035h
	Port P6 input	P6IN	034h
Port P5	Port P5 selection	P5SEL	033h
	Port P5 direction	P5DIR	032h
	Port P5 output	P5OUT	031h
	Port P5 input	P5IN	030h
Port P4	Port P4 selection	P4SEL	01Fh
	Port P4 direction	P4DIR	01Eh
	Port P4 output	P4OUT	01Dh
	Port P4 input	P4IN	01Ch
Port P3	Port P3 selection	P3SEL	01Bh
	Port P3 direction	P3DIR	01Ah
	Port P3 output	P3OUT	019h
	Port P3 input	P3IN	018h
Port P2	Port P2 selection	P2SEL	02Eh
	Port P2 interrupt enable	P2IE	02Dh
	Port P2 interrupt-edge select	P2IES	02Ch
	Port P2 interrupt flag	P2IFG	02Bh
	Port P2 direction	P2DIR	02Ah
	Port P2 output	P2OUT	029h
	Port P2 input	P2IN	028h
Port P1	Port P1 selection	P1SEL	026h
	Port P1 interrupt enable	P1IE	025h
	Port P1 interrupt-edge select	P1IES	024h
	Port P1 interrupt flag	P1IFG	023h
	Port P1 direction	P1DIR	022h
	Port P1 output	P1OUT	021h
	Port P1 input	P1IN	020h
Special Functions	SFR module enable 2	ME2	005h
	SFR module enable 1	ME1	004h
	SFR interrupt flag 2	IFG2	003h
	SFR interrupt flag 1	IFG1	002h
	SFR interrupt enable 2	IE2	001h
	SFR interrupt enable 1	IE1	000h

MSP430C13x1 MIXED SIGNAL MICROCONTROLLER

SLAS341B – SEPTEMBER 2001 – REVISED SEPTEMBER 2004

absolute maximum ratings over operating free-air temperature (unless otherwise noted)†

Voltage applied at V_{CC} to V_{SS}	-0.3 V to + 4.1 V
Voltage applied to any pin (see Note)	-0.3 V to $V_{CC}+0.3$ V
Diode current at any device terminal	± 2 mA
Storage temperature (unprogrammed device)	-55°C to 150°C
Storage temperature (programmed device)	-40°C to 85°C

† Stresses beyond those listed under “absolute maximum ratings” may cause permanent damage to the device. These are stress ratings only, and functional operation of the device at these or any other conditions beyond those indicated under “recommended operating conditions” is not implied. Exposure to absolute-maximum-rated conditions for extended periods may affect device reliability.

NOTE: All voltages referenced to V_{SS} . The JTAG fuse-blow voltage, V_{FB} , is allowed to exceed the absolute maximum rating. The voltage is applied to the TDI/TCLK pin when blowing the JTAG fuse.

recommended operating conditions

PARAMETER		MIN	NOM	MAX	UNITS	
Supply voltage during program execution, V_{CC} ($AV_{CC} = DV_{CC} = V_{CC}$)		1.8		3.6	V	
Supply voltage, V_{SS} ($AV_{SS} = DV_{SS} = V_{SS}$)		0.0		0.0	V	
Operating free-air temperature range, T_A		-40		85	°C	
LFXT1 crystal frequency, $f_{(LFXT1)}$ (see Notes 1 and 2)	LF selected, XTS=0	Watch crystal		32768	Hz	
	XT1 selected, XTS=1	Ceramic resonator		450	8000	kHz
	XT1 selected, XTS=1	Crystal		1000	8000	kHz
XT2 crystal frequency, $f_{(XT2)}$	Ceramic resonator		450	8000	kHz	
	Crystal		1000	8000		
Processor frequency (signal MCLK), $f_{(System)}$	$V_{CC} = 1.8$ V		DC	4.15	MHz	
	$V_{CC} = 3.6$ V		DC	8		

- NOTES: 1. In LF mode, the LFXT1 oscillator requires a watch crystal and the LFXT1 oscillator requires a 5.1-M Ω resistor from XOUT to V_{SS} when $V_{CC} < 2.5$ V. In XT1 mode, the LFXT1 and XT2 oscillators accept a ceramic resonator or a 4-MHz crystal frequency at $V_{CC} \geq 2.2$ V. In XT1 mode, the LFXT1 and XT2 oscillators accept a ceramic resonator or an 8-MHz crystal frequency at $V_{CC} \geq 2.8$ V.
2. In LF mode, the LFXT1 oscillator requires a watch crystal. In XT1 mode, FXT1 accepts a ceramic resonator or a crystal.

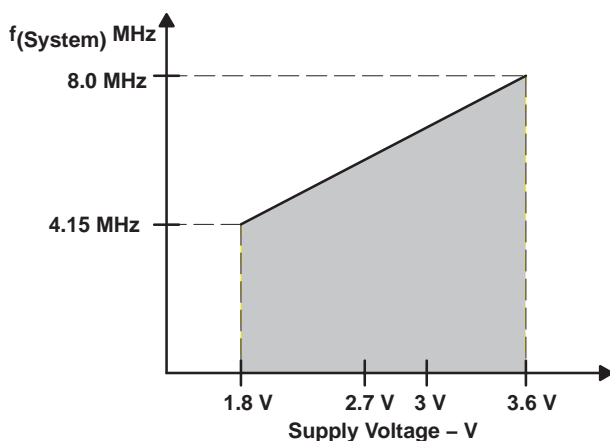

Figure 1. Frequency vs Supply Voltage

MSP430C13x1 MIXED SIGNAL MICROCONTROLLER

SLAS341B – SEPTEMBER 2001 – REVISED SEPTEMBER 2004

electrical characteristics over recommended operating free-air temperature (unless otherwise noted)

supply current into V_{CC} + DV_{CC} excluding external current

PARAMETER		TEST CONDITIONS	MIN	NOM	MAX	UNIT		
$I_{(AM)}$	Active mode, (see Note 1) $f_{(MCLK)} = f_{(SMCLK)} = 1$ MHz, $f_{(ACLK)} = 32,768$ Hz, XTS=0, SELM=(0,1)	$T_A = -40^\circ\text{C}$ to 85°C	$V_{CC} = 2.2$ V	160	200	μA		
			$V_{CC} = 3$ V	240	300			
$I_{(AM)}$	Active mode, (see Note 1) $f_{(MCLK)} = f_{(SMCLK)} = 4.096$ Hz, $f_{(ACLK)} = 4,096$ Hz XTS=0, SELM=(0,1), XTS=0, SELM=3	$T_A = -40^\circ\text{C}$ to 85°C	$V_{CC} = 2.2$ V	2.5	7	μA		
			$V_{CC} = 3$ V	2.5	7			
$I_{(LPM0)}$	Low-power mode, (LPM0) (see Note 1)	$T_A = -40^\circ\text{C}$ to 85°C	$V_{CC} = 2.2$ V	32	45	μA		
			$V_{CC} = 3$ V	55	70			
$I_{(LPM2)}$	Low-power mode, (LPM2), $f_{(MCLK)} = f_{(SMCLK)} = 0$ MHz, $f_{(ACLK)} = 32.768$ Hz, SCG0 = 0	$T_A = -40^\circ\text{C}$ to 85°C	$V_{CC} = 2.2$ V	11	14	μA		
			$V_{CC} = 3$ V	17	22			
$I_{(LPM3)}$	Low-power mode, (LPM3) $f_{(MCLK)} = f_{(SMCLK)} = 0$ MHz, $f_{(ACLK)} = 32,768$ Hz, SCG0 = 1 (see Note 2)	$T_A = -40^\circ\text{C}$	$V_{CC} = 2.2$ V	0.8	1.5	μA		
				$T_A = 25^\circ\text{C}$	0.9		1.5	
				$T_A = 85^\circ\text{C}$	1.6		2.8	
		$T_A = -40^\circ\text{C}$		$V_{CC} = 3$ V	1.8	2.2	μA	
					$T_A = 25^\circ\text{C}$	1.8		2.2
					$T_A = 85^\circ\text{C}$	2.3		3.9
$I_{(LPM4)}$	Low-power mode, (LPM4) $f_{(MCLK)} = 0$ MHz, $f_{(SMCLK)} = 0$ MHz, $f_{(ACLK)} = 0$ Hz, SCG0 = 1	$T_A = -40^\circ\text{C}$	$V_{CC} = 2.2$ V		0.1	0.5	μA	
					$T_A = 25^\circ\text{C}$	0.1		0.5
					$T_A = 85^\circ\text{C}$	0.8		2.5
		$T_A = -40^\circ\text{C}$		$V_{CC} = 3$ V	0.1	0.5	μA	
					$T_A = 25^\circ\text{C}$	0.1		0.5
					$T_A = 85^\circ\text{C}$	0.8		2.5

NOTES: 1. Timer_B is clocked by $f_{(DCOCLK)} = 1$ MHz. All inputs are tied to 0 V or to V_{CC} . Outputs do not source or sink any current.
2. Timer_B is clocked by $f_{(ACLK)} = 32,768$ Hz. All inputs are tied to 0 V or to V_{CC} . Outputs do not source or sink any current. The current consumption in LPM2 and LPM3 are measured with ACLK selected.

Current consumption of active mode versus system frequency

$$I_{(AM)} = I_{(AM)} [1 \text{ MHz}] \times f_{(\text{System})} [\text{MHz}]$$

Current consumption of active mode versus supply voltage

$$I_{(AM)} = I_{(AM)} [3 \text{ V}] + 175 \mu\text{A/V} \times (V_{CC} - 3 \text{ V})$$

MSP430C13x1 MIXED SIGNAL MICROCONTROLLER

SLAS341B – SEPTEMBER 2001 – REVISED SEPTEMBER 2004

electrical characteristics over recommended operating free-air temperature (unless otherwise noted)

SCHMITT-trigger inputs – Ports P1, P2, P3, P4, P5, and P6

PARAMETER		TEST CONDITIONS	MIN	TYP	MAX	UNIT
V _{IT+}	Positive-going input threshold voltage	V _{CC} = 2.2 V	1.1		1.5	V
		V _{CC} = 3 V	1.5		1.9	
V _{IT-}	Negative-going input threshold voltage	V _{CC} = 2.2 V	0.4		0.9	V
		V _{CC} = 3 V	0.90		1.3	
V _{hys}	Input voltage hysteresis (V _{IT+} – V _{IT-})	V _{CC} = 2.2 V	0.3		1.1	V
		V _{CC} = 3 V	0.4		1	

standard inputs – \overline{RST}/NMI ; JTAG: TCK, TMS, TDI/TCLK, TDO/TDI

PARAMETER		TEST CONDITIONS	MIN	TYP	MAX	UNIT
V _{IL}	Low-level input voltage	V _{CC} = 2.2 V / 3 V	V _{SS}		V _{SS} +0.6	V
V _{IH}	High-level input voltage		0.8×V _{CC}		V _{CC}	V

input frequency – Ports P1, P2, P3, P4, P5, and P6

PARAMETER		TEST CONDITIONS		MIN	TYP	MAX	UNIT
f _(IN)		t _(h) = t _(L)	V _{CC} = 2.2 V			8	MHz
			V _{CC} = 3 V			10	

capture timing _ Timer_A3: TA0, TA1, TA2; Timer_B3: TB0, TB1, TB2

PARAMETER		TEST CONDITIONS	MIN	TYP	MAX	UNIT
t _(int)	Ports P2, P4: External trigger signal for the interrupt flag (see Notes 1 and 2)	V _{CC} = 2.2 V/3 V	1.5			Cycle
		V _{CC} = 2.2 V	62			ns
		V _{CC} = 3 V	50			

- NOTES: 1. The external signal sets the interrupt flag every time t_(int) is met. It may be set even with trigger signals shorter than t_(int). The conditions to set the flag must be met independently of this timing constraint. t_(int) is defined in MCLK cycles.
2. The external signal needs additional timing because of the maximum input-frequency constraint.

external interrupt timing

PARAMETER		TEST CONDITIONS	MIN	TYP	MAX	UNIT
t _(int)	Ports P1, P2: External trigger signal for the interrupt flag (see Notes 1 and 2)	V _{CC} = 2.2 V/3 V	1.5			Cycle
		V _{CC} = 2.2 V	62			ns
		V _{CC} = 3 V	50			

- NOTES: 1. The external signal sets the interrupt flag every time t_(int) is met. It may be set even with trigger signals shorter than t_(int). The conditions to set the flag must be met independently of this timing constraint. t_(int) is defined in MCLK cycles.
2. The external signal needs additional timing because of the maximum input-frequency constraint.

leakage current (see Note 1)

PARAMETER		TEST CONDITIONS		MIN	TYP	MAX	UNIT
I _{lkg} (P1.x)	Leakage current	Port P1	V _(P1.x) (see Note 2)	V _{CC} = 2.2 V/3 V		±50	nA
I _{lkg} (P2.x)		Port P2	V _(P2.3) V _(P2.4) (see Note 2)			±50	

- NOTES: 1. The leakage current is measured with V_{SS} or V_{CC} applied to the corresponding pin(s), unless otherwise noted.
2. The port pin must be selected as input and there must be no optional pullup or pulldown resistor.

MSP430C13x1 MIXED SIGNAL MICROCONTROLLER

SLAS341B – SEPTEMBER 2001 – REVISED SEPTEMBER 2004

electrical characteristics over recommended operating free-air temperature (unless otherwise noted) (continued)

outputs – Ports P1, P2, P3, P4, P5, and P6

PARAMETER		TEST CONDITIONS	MIN	TYP	MAX	UNIT
V _{OH}	High-level output voltage	I _{OH(max)} = -1.5 mA, V _{CC} = 2.2 V, See Note 1	V _{CC} -0.25		V _{CC}	V
		I _{OH(max)} = -6 mA, V _{CC} = 2.2 V, See Note 2	V _{CC} -0.6		V _{CC}	
		I _{OH(max)} = -1.5 mA, V _{CC} = 3 V, See Note 1	V _{CC} -0.25		V _{CC}	
		I _{OH(max)} = -6 mA, V _{CC} = 3 V, See Note 2	V _{CC} -0.6		V _{CC}	
V _{OL}	Low-level output voltage	I _{OL(max)} = 1.5 mA, V _{CC} = 2.2 V, See Note 1	V _{SS}		V _{SS} +0.25	V
		I _{OL(max)} = 6 mA, V _{CC} = 2.2 V, See Note 2	V _{SS}		V _{SS} +0.6	
		I _{OL(max)} = 1.5 mA, V _{CC} = 3 V, See Note 1	V _{SS}		V _{SS} +0.25	
		I _{OL(max)} = 6 mA, V _{CC} = 3 V, See Note 2	V _{SS}		V _{SS} +0.6	

- NOTES: 1. The maximum total current, I_{OH(max)} and I_{OL(max)}, for all outputs combined, should not exceed ±12 mA to satisfy the maximum specified voltage drop.
 2. The maximum total current, I_{OH(max)} and I_{OL(max)}, for all outputs combined, should not exceed ±48 mA to satisfy the maximum specified voltage drop.

output frequency

PARAMETER		TEST CONDITIONS	MIN	TYP	MAX	UNIT
f _{TAx} , f _{TBx}	TA0..2, TB0..2 Internal clock source, SMCLK signal applied (see Note 1)	C _L = 20 pF	DC	f _{System}		MHz
f _{ACLK} , f _{MCLK} , f _{SMCLK}	P5.6/ACLK, P5.4/MCLK, P5.5/SMCLK	C _L = 20 pF		f _{System}		
t _{Xdc}	Duty cycle of output frequency	P2.0/ACLK C _L = 20 pF, V _{CC} = 2.2 V / 3 V	f _{ACLK} = f _{LFXT1} = f _{XT1}	40%	60%	
			f _{ACLK} = f _{LFXT1} = f _{LF}	30%	70%	
			f _{ACLK} = f _{LFXT1/n}		50%	
		P1.4/SMCLK, C _L = 20 pF, V _{CC} = 2.2 V / 3 V	f _{SMCLK} = f _{LFXT1} = f _{XT1}	40%	60%	
			f _{SMCLK} = f _{LFXT1} = f _{LF}	35%	65%	
			f _{SMCLK} = f _{LFXT1/n}	50%– 15 ns	50%	50%– 15 ns
f _{SMCLK} = f _{DCOCLK}	50%– 15 ns	50%	50%– 15 ns			

NOTE 1: The limits of the system clock MCLK has to be met; the system (MCLK) frequency should not exceed the limits. MCLK and SMCLK frequencies can be different.

MSP430C13x1 MIXED SIGNAL MICROCONTROLLER

SLAS341B – SEPTEMBER 2001 – REVISED SEPTEMBER 2004

electrical characteristics over recommended operating free-air temperature (unless otherwise noted) (continued)

outputs – Ports P1, P2, P3, P4, P5, and P6 (continued)

TYPICAL LOW-LEVEL OUTPUT CURRENT
vs
LOW-LEVEL OUTPUT VOLTAGE

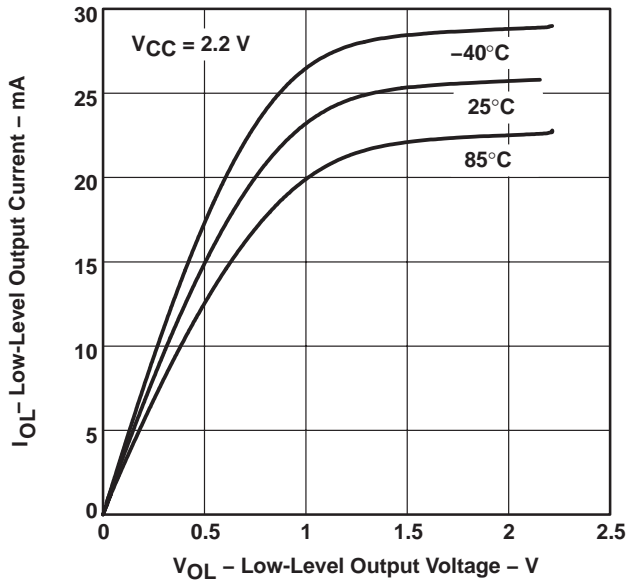

Figure 2

TYPICAL LOW-LEVEL OUTPUT CURRENT
vs
LOW-LEVEL OUTPUT VOLTAGE

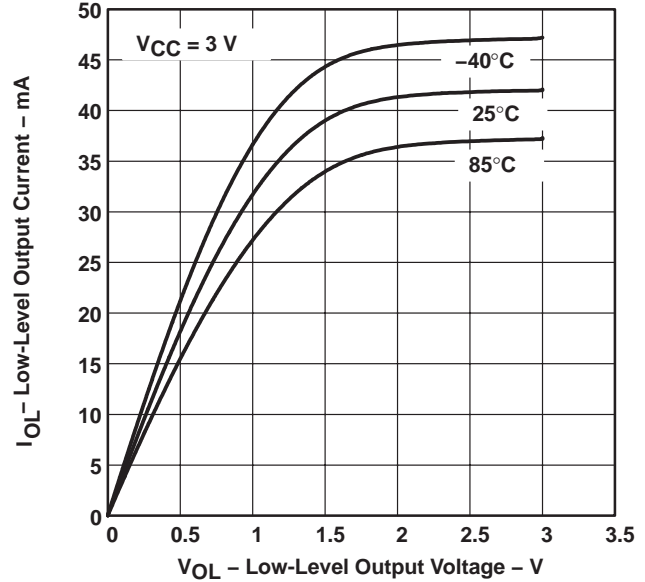

Figure 3

TYPICAL HIGH-LEVEL OUTPUT CURRENT
vs
HIGH-LEVEL OUTPUT VOLTAGE

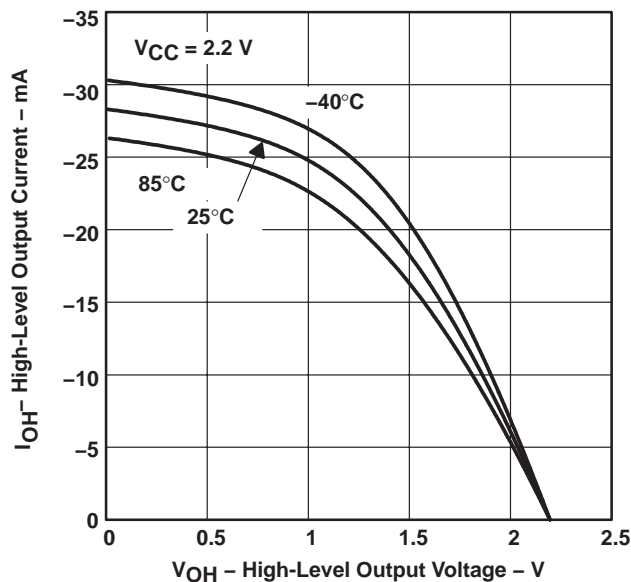

Figure 4

TYPICAL HIGH-LEVEL OUTPUT CURRENT
vs
HIGH-LEVEL OUTPUT VOLTAGE

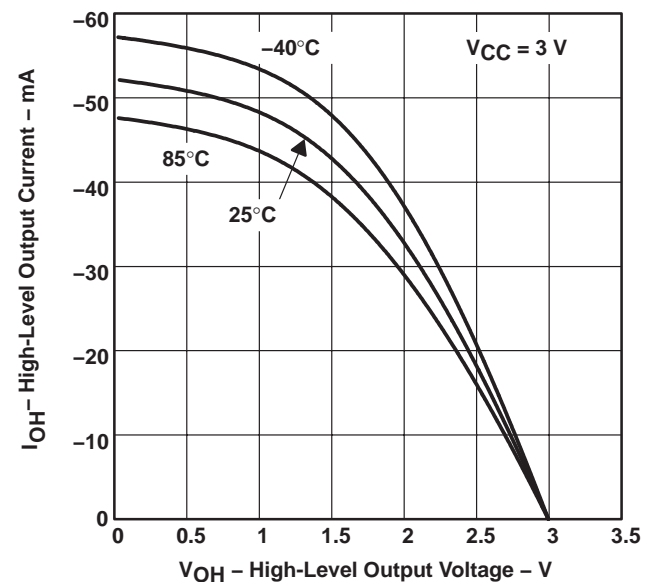

Figure 5

MSP430C13x1 MIXED SIGNAL MICROCONTROLLER

SLAS341B – SEPTEMBER 2001 – REVISED SEPTEMBER 2004

electrical characteristics over recommended operating free-air temperature (unless otherwise noted) (continued)

wake-up LPM3

PARAMETER	TEST CONDITIONS	MIN	TYP	MAX	UNIT
t(LPM3) Delay time	f = 1 MHz			6	μs
	f = 2 MHz	V _{CC} = 2.2 V/3 V		6	
	f = 3 MHz			6	

RAM

PARAMETER	TEST CONDITIONS	MIN	TYP	MAX	UNIT
V _{RAMh}	CPU HALTED (see Note 1)	1.6			V

NOTE 1: This parameter defines the minimum supply voltage when the data in program memory RAM remain unchanged. No program execution should take place during this supply voltage condition.

Comparator_A (see Note 1)

PARAMETER	TEST CONDITIONS	MIN	TYP	MAX	UNIT		
I _(DD)	CAON=1, CARSEL=0, CAREF=0	V _{CC} = 2.2 V	30	47	μA		
		V _{CC} = 3 V	55	74			
I _(Ref ladder/Ref diode)	CAON=1, CARSEL=0, CAREF=1/2/3, no load at P2.3/CA0/TA1 and P2.4/CA1/TA2	V _{CC} = 2.2 V	40	57	μA		
		V _{CC} = 3 V	60	87			
V _(IC) Common-mode input voltage	CAON =1	V _{CC} = 2.2 V/3 V		0	V _{CC} -1	V	
V _(Ref025)	Voltage at 0.25 V _{CC} node $\frac{V_{CC}}{4}$	PCA0=1, CARSEL=1, CAREF=1, no load at P2.3/CA0/TA1 and P2.4/CA1/TA2	V _{CC} = 2.2 V/3 V		0.23	0.24	0.25
V _(Ref050)	Voltage at 0.5V _{CC} node $\frac{V_{CC}}{2}$	PCA0=1, CARSEL=1, CAREF=2, no load at P2.3/CA0/TA1 and P2.4/CA1/TA2	V _{CC} = 2.2 V/3 V		0.47	0.48	0.5
V _(RefVT) (see Figure 6 and Figure 7)	PCA0=1, CARSEL=1, CAREF=3, no load at P2.3/CA0/TA1 and P2.4/CA1/TA2 T _A = 85°C	V _{CC} = 2.2 V	390	480	540	mV	
		V _{CC} = 3 V	400	490	550		
V _(offset) Offset voltage	See Note 2	V _{CC} = 2.2 V/3 V		-30		30	mV
V _(hys) Input hysteresis	CAON=1	V _{CC} = 2.2 V/3 V		0	0.7	1.4	mV
t _(response LH)	T _A = 25°C, Overdrive 10 mV, Without filter: CAF=0	V _{CC} = 2.2 V	130	210	300	ns	
		V _{CC} = 3 V	80	150	240		
	T _A = 25°C, Overdrive 10 mV, With filter: CAF=1	V _{CC} = 2.2 V	1.4	1.9	3.4	μs	
		V _{CC} = 3 V	0.9	1.5	2.6		
t _(response HL)	T _A = 25°C, Overdrive 10 mV, Without filter: CAF=0	V _{CC} = 2.2 V	130	210	300	ns	
		V _{CC} = 3 V	80	150	240		
	T _A = 25°C, Overdrive 10 mV, With filter: CAF=1	V _{CC} = 2.2 V	1.4	1.9	3.4	μs	
		V _{CC} = 3 V	0.9	1.5	2.6		

NOTES: 1. The leakage current for the Comparator_A terminals is identical to I_{lkg}(P_{x.x}) specification.
 2. The input offset voltage can be cancelled by using the CAEX bit to invert the Comparator_A inputs on successive measurements. The two successive measurements are then summed together.

MSP430C13x1 MIXED SIGNAL MICROCONTROLLER

SLAS341B – SEPTEMBER 2001 – REVISED SEPTEMBER 2004

electrical characteristics over recommended operating free-air temperature (unless otherwise noted) (continued)

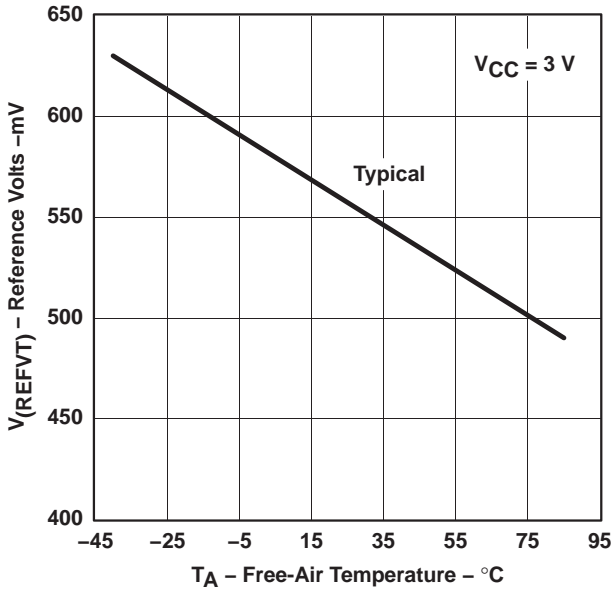

Figure 6. V_(RefVT) vs Temperature, V_{CC} = 3 V

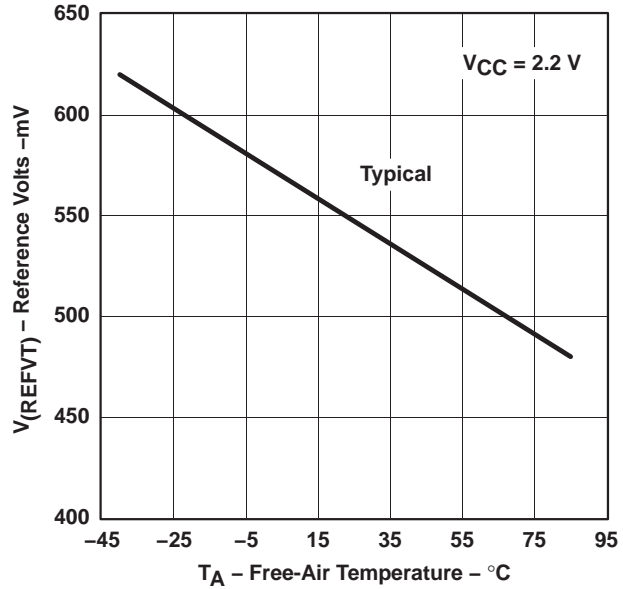

Figure 7. V_(RefVT) vs Temperature, V_{CC} = 2.2 V

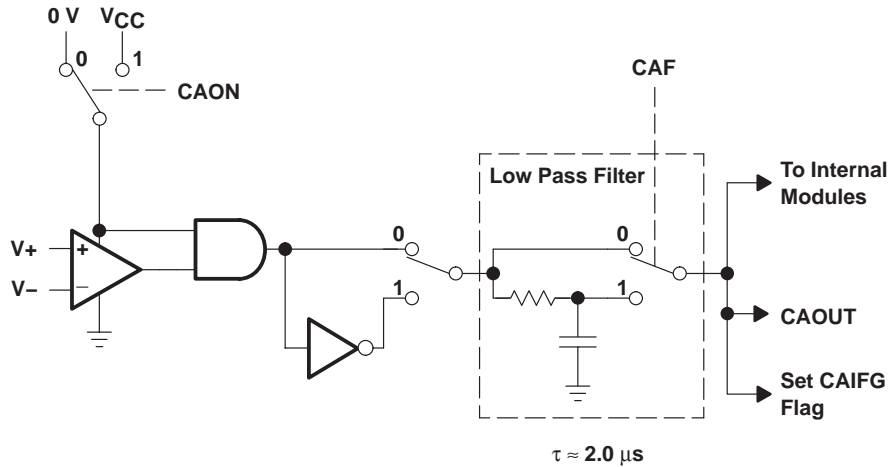

Figure 8. Block Diagram of Comparator_A Module

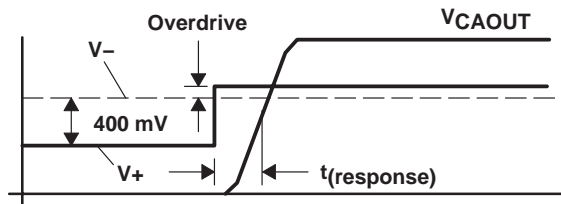

Figure 9. Overdrive Definition

MSP430C13x1 MIXED SIGNAL MICROCONTROLLER

SLAS341B – SEPTEMBER 2001 – REVISED SEPTEMBER 2004

electrical characteristics over recommended operating free-air temperature (unless otherwise noted) (continued)

PUC/POR

PARAMETER	TEST CONDITIONS	MIN	TYP	MAX	UNIT	
$t_{(POR_Delay)}$	Internal time delay to release POR		150	250	μs	
V_{POR}	V_{CC} threshold at which POR release delay time begins (see Note 1)	$T_A = -40^\circ C$		1.4	1.8	V
		$T_A = 25^\circ C$		1.1	1.5	V
		$T_A = 85^\circ C$		0.8	1.2	V
$V_{(min)}$	V_{CC} threshold required to generate a POR (see Note 2)	$V_{CC} dV/dt \geq 1V/ms$		0.2	V	
$t_{(reset)}$	\overline{RST}/NMI low time for PUC/POR	Reset is accepted internally		2	μs	

- NOTES: 1. V_{CC} rise time $dV/dt \geq 1V/ms$.
 2. When driving V_{CC} low in order to generate a POR condition, V_{CC} should be driven to 200mV or lower with a dV/dt equal to or less than $-1V/ms$. The corresponding rising V_{CC} must also meet the dV/dt requirement equal to or greater than $+1V/ms$.

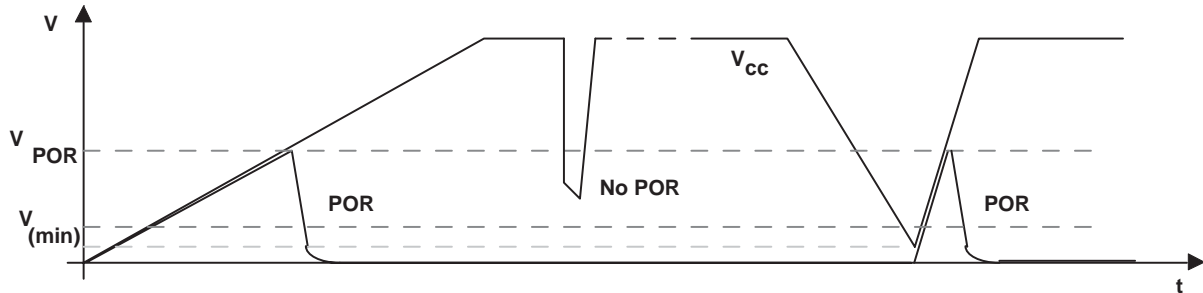

Figure 10. Power-On Reset (POR) vs Supply Voltage

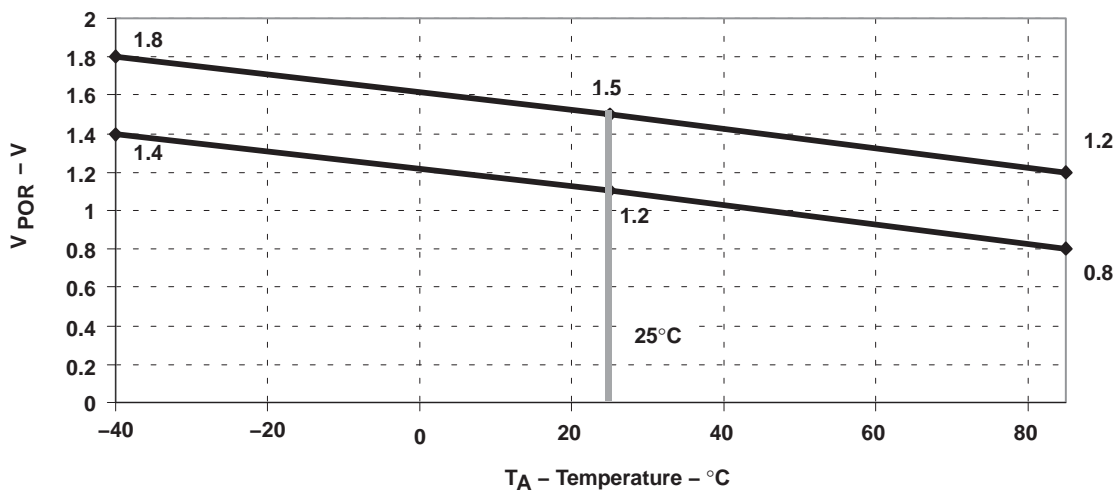

Figure 11. V_{POR} vs Temperature

MSP430C13x1 MIXED SIGNAL MICROCONTROLLER

SLAS341B – SEPTEMBER 2001 – REVISED SEPTEMBER 2004

electrical characteristics over recommended operating free-air temperature (unless otherwise noted) (continued)

DCO (see Note 1)

PARAMETER	TEST CONDITIONS	MIN	NOM	MAX	UNIT	
f(DCO03)	Rsel = 0, DCO = 3, MOD = 0, DCOR = 0, TA = 25°C	VCC = 2.2 V	0.08	0.12	0.15	MHz
		VCC = 3 V	0.08	0.13	0.16	
f(DCO13)	Rsel = 1, DCO = 3, MOD = 0, DCOR = 0, TA = 25°C	VCC = 2.2 V	0.14	0.19	0.23	MHz
		VCC = 3 V	0.14	0.18	0.22	
f(DCO23)	Rsel = 2, DCO = 3, MOD = 0, DCOR = 0, TA = 25°C	VCC = 2.2 V	0.22	0.30	0.36	MHz
		VCC = 3 V	0.22	0.28	0.34	
f(DCO33)	Rsel = 3, DCO = 3, MOD = 0, DCOR = 0, TA = 25°C	VCC = 2.2 V	0.37	0.49	0.59	MHz
		VCC = 3 V	0.37	0.47	0.56	
f(DCO43)	Rsel = 4, DCO = 3, MOD = 0, DCOR = 0, TA = 25°C	VCC = 2.2 V	0.61	0.77	0.93	MHz
		VCC = 3 V	0.61	0.75	0.90	
f(DCO53)	Rsel = 5, DCO = 3, MOD = 0, DCOR = 0, TA = 25°C	VCC = 2.2 V	1	1.2	1.5	MHz
		VCC = 3 V	1	1.3	1.5	
f(DCO63)	Rsel = 6, DCO = 3, MOD = 0, DCOR = 0, TA = 25°C	VCC = 2.2 V	1.6	1.9	2.2	MHz
		VCC = 3 V	1.69	2.0	2.29	
f(DCO73)	Rsel = 7, DCO = 3, MOD = 0, DCOR = 0, TA = 25°C	VCC = 2.2 V	2.4	2.9	3.4	MHz
		VCC = 3 V	2.7	3.2	3.65	
f(DCO47)	Rsel = 4, DCO = 7, MOD = 0, DCOR = 0, TA = 25°C	VCC = 2.2 V/3 V	f _{DCO40} × 1.7	f _{DCO40} × 2.1	f _{DCO40} × 2.5	MHz
f(DCO77)	Rsel = 7, DCO = 7, MOD = 0, DCOR = 0, TA = 25°C	VCC = 2.2 V	4	4.5	4.9	MHz
		VCC = 3 V	4.4	4.9	5.4	
S(Rsel)	SR = f _{Rsel+1} / f _{Rsel}	VCC = 2.2 V/3 V	1.35	1.65	2	
S(DCO)	S _{DCO} = f _{DCO+1} / f _{DCO}	VCC = 2.2 V/3 V	1.07	1.12	1.16	
Dt	Temperature drift, Rsel = 4, DCO = 3, MOD = 0 (see Note 2)	VCC = 2.2 V	-0.31	-0.36	-0.40	%°C
		VCC = 3 V	-0.33	-0.38	-0.43	
DV	Drift with VCC variation, Rsel = 4, DCO = 3, MOD = 0 (see Note 2)	VCC = 2.2 V/3 V	0	5	10	%/V

NOTES: 1. The DCO frequency may not exceed the maximum system frequency defined by parameter processor frequency, f_(System).
2. This parameter is not production tested.

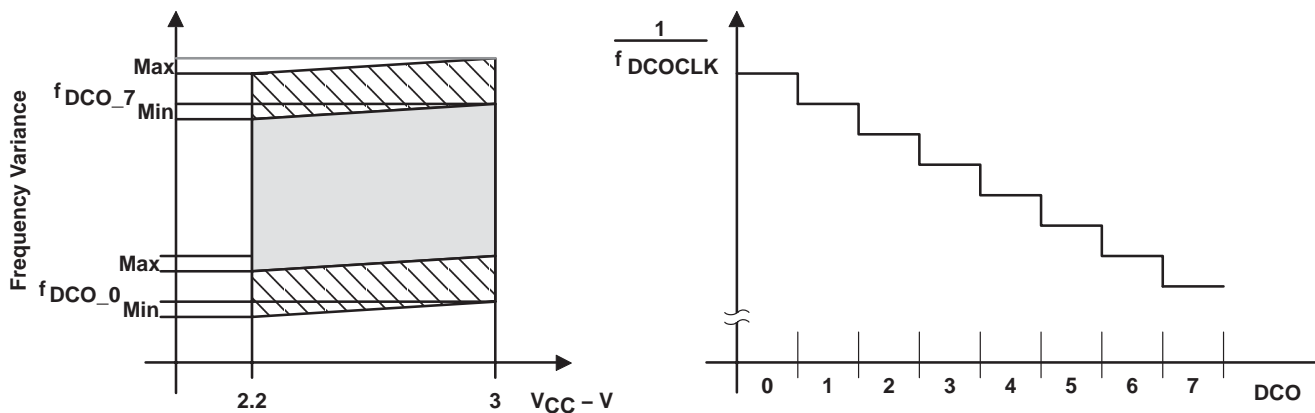

Figure 12. DCO Characteristics

MSP430C13x1 MIXED SIGNAL MICROCONTROLLER

SLAS341B – SEPTEMBER 2001 – REVISED SEPTEMBER 2004

electrical characteristics over recommended operating free-air temperature (unless otherwise noted) (continued)

main DCO characteristics

- Individual devices have a minimum and maximum operation frequency. The specified parameters for $f_{(DCOx0)}$ to $f_{(DCOx7)}$ are valid for all devices.
- All ranges selected by $R_{sel}(n)$ overlap with $R_{sel}(n+1)$: R_{sel0} overlaps R_{sel1} , ... R_{sel6} overlaps R_{sel7} .
- DCO control bits DCO0, DCO1, and DCO2 have a step size as defined by parameter S_{DCO} .
- Modulation control bits MOD0 to MOD4 select how often $f_{(DCO+1)}$ is used within the period of 32 DCOCLK cycles. The frequency $f_{(DCO)}$ is used for the remaining cycles. The frequency is an average equal to:

$$f_{average} = \frac{32 \times f_{(DCO)} \times f_{(DCO+1)}}{MOD \times f_{(DCO)} + (32 - MOD) \times f_{(DCO+1)}}$$

DCO when using R_{OSC} (see Note 1)

PARAMETER	TEST CONDITIONS	V_{CC}	MIN	NOM	MAX	UNIT
f_{DCO} , DCO output frequency	$R_{sel} = 4$, DCO = 3, MOD = 0, DCOR = 1, $T_A = 25^\circ\text{C}$	2.2 V		2.0±15%		MHz
		3 V		2.1±15%		MHz
D_t , Temperature drift	$R_{sel} = 4$, DCO = 3, MOD = 0, DCOR = 1	2.2 V/3 V		±0.1		%/°C
D_v , Drift with V_{CC} variation	$R_{sel} = 4$, DCO = 3, MOD = 0, DCOR = 1	2.2 V/3 V		10		%/V

NOTES: 1. $R_{OSC} = 100\text{k}\Omega$. Metal film resistor, type 0257. 0.6 watt with 1% tolerance and $T_K = \pm 50\text{ppm}/^\circ\text{C}$.

crystal oscillator, LFXT1 oscillator (see Note 1)

PARAMETER	TEST CONDITIONS	MIN	NOM	MAX	UNIT
C_{XIN} Integrated input capacitance	XTS=0; LF oscillator selected $V_{CC} = 2.2\text{ V}/3\text{ V}$		12		pF
	XTS=1; XT1 oscillator selected $V_{CC} = 2.2\text{ V}/3\text{ V}$		2		
C_{XOUT} Integrated output capacitance	XTS=0; LF oscillator selected $V_{CC} = 2.2\text{ V}/3\text{ V}$		12		pF
	XTS=1; XT1 oscillator selected $V_{CC} = 2.2\text{ V}/3\text{ V}$		2		
V_{IL}	Input levels at XIN $V_{CC} = 2.2\text{ V}/3\text{ V}$ (see Note 2)	V_{SS}		$0.2 \times V_{CC}$	V
V_{IH}		$0.8 \times V_{CC}$		V_{CC}	V

NOTES: 1. The oscillator needs capacitors at both terminals, with values specified by the crystal manufacturer.
2. Applies only when using an external logic-level clock source. Not applicable when using a crystal or resonator.

crystal oscillator, XT2 oscillator (see Note 1)

PARAMETER	TEST CONDITIONS	MIN	NOM	MAX	UNIT
C_{XIN} Integrated input capacitance	$V_{CC} = 2.2\text{ V}/3\text{ V}$		2		pF
C_{XOUT} Integrated output capacitance	$V_{CC} = 2.2\text{ V}/3\text{ V}$		2		pF
V_{IL}	Input levels at XT2IN $V_{CC} = 2.2\text{ V}/3\text{ V}$ (see Note 2)	V_{SS}		$0.2 \times V_{CC}$	V
V_{IH}		$0.8 \times V_{CC}$		V_{CC}	V

NOTES: 1. The oscillator needs capacitors at both terminals, with values specified by the crystal manufacturer.
2. Applies only when using an external logic-level clock source. Not applicable when using a crystal or resonator.

USART0 (see Note 1)

PARAMETER	TEST CONDITIONS	MIN	NOM	MAX	UNIT
$t_{(\tau)}$ USART0: deglitch time	$V_{CC} = 2.2\text{ V}$	200	430	800	ns
	$V_{CC} = 3\text{ V}$	150	280	500	

NOTE 1: The signal applied to the USART0 receive signal/terminal (URXD0) should meet the timing requirements of $t_{(\tau)}$ to ensure that the URXS flip-flop is set. The URXS flip-flop is set with negative pulses meeting the minimum-timing condition of $t_{(\tau)}$. The operating conditions to set the flag must be met independently from this timing constraint. The deglitch circuitry is active only on negative transitions on the URXD0 line.

MSP430C13x1 MIXED SIGNAL MICROCONTROLLER

SLAS341B – SEPTEMBER 2001 – REVISED SEPTEMBER 2004

electrical characteristics over recommended operating free-air temperature (unless otherwise noted) (continued)

JTAG Interface

PARAMETER		TEST CONDITIONS	V _{CC}	MIN	NOM	MAX	UNIT
f _{TCK}	TCK input frequency	see Note 1	2.2 V	0		5	MHz
			3 V	0		10	MHz
R _{Internal}	Internal pull-up resistance on TMS, TCK, TDI/TCLK	see Note 2	2.2 V/ 3 V	25	60	90	kΩ

NOTES: 1. f_{TCK} may be restricted to meet the timing requirements of the module selected.
2. TMS, TDI/TCLK, and TCK pull-up resistors are implemented in all versions.

JTAG Fuse (see Note 1)

PARAMETER		TEST CONDITIONS	V _{CC}	MIN	NOM	MAX	UNIT
V _{FB}	Voltage level on TDI/TCLK for fuse-blow		3.6V	5		5.5	V
I _{FB}	Supply current into TDI/TCLK during fuse blow					100	mA
t _{FB}	Time to blow fuse					20	ms

NOTES: 1. Once the fuse is blown, no further access to the MSP430 JTAG/Test and emulation features is possible. The JTAG block is switched to bypass mode.

APPLICATION INFORMATION

input/output schematic

port P1, P1.0 to P1.7, input/output with Schmitt-trigger

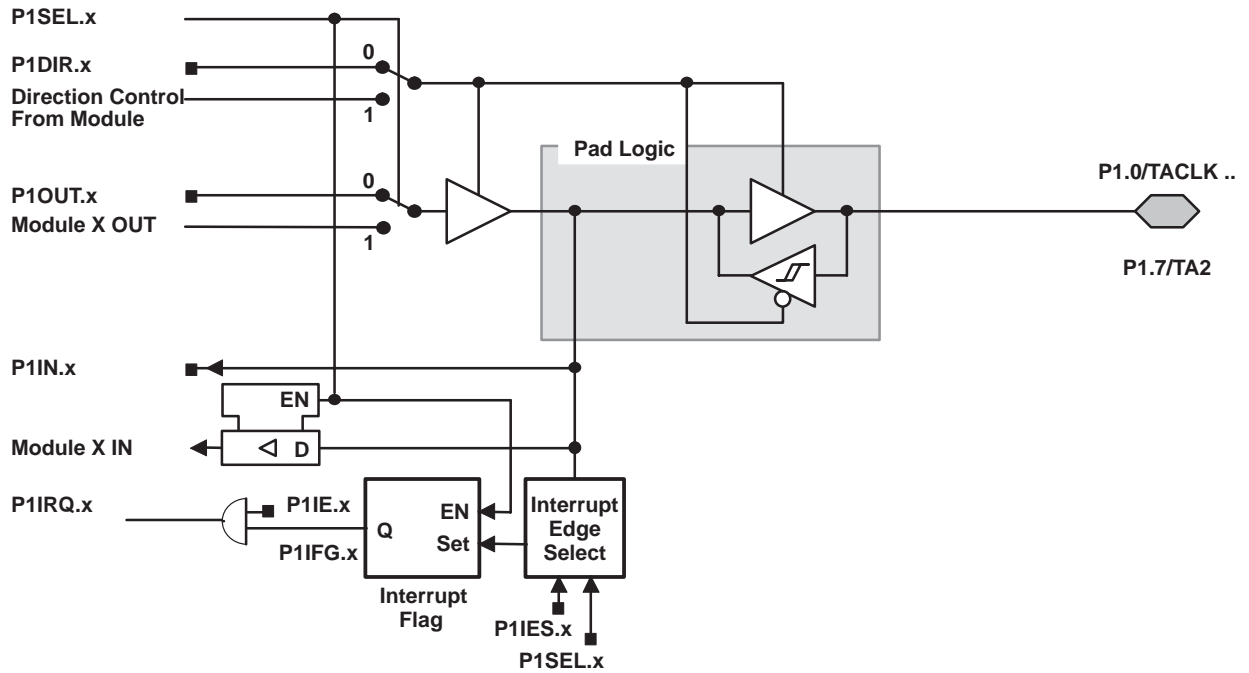

PnSel.x	PnDIR.x	Dir. CONTROL FROM MODULE	PnOUT.x	MODULE X OUT	PnIN.x	MODULE X IN	PnIE.x	PnIFG.x	PnIES.x
P1Sel.0	P1DIR.0	P1DIR.0	P1OUT.0	DV _{SS}	P1IN.0	TACLK [†]	P1IE.0	P1IFG.0	P1IES.0
P1Sel.1	P1DIR.1	P1DIR.1	P1OUT.1	Out0 signal [†]	P1IN.1	CCI0A [†]	P1IE.1	P1IFG.1	P1IES.1
P1Sel.2	P1DIR.2	P1DIR.2	P1OUT.2	Out1 signal [†]	P1IN.2	CCI1A [†]	P1IE.2	P1IFG.2	P1IES.2
P1Sel.3	P1DIR.3	P1DIR.3	P1OUT.3	Out2 signal [†]	P1IN.3	CCI2A [†]	P1IE.3	P1IFG.3	P1IES.3
P1Sel.4	P1DIR.4	P1DIR.4	P1OUT.4	SMCLK	P1IN.4	unused	P1IE.4	P1IFG.4	P1IES.4
P1Sel.5	P1DIR.5	P1DIR.5	P1OUT.5	Out0 signal [†]	P1IN.5	unused	P1IE.5	P1IFG.5	P1IES.5
P1Sel.6	P1DIR.6	P1DIR.6	P1OUT.6	Out1 signal [†]	P1IN.6	unused	P1IE.6	P1IFG.6	P1IES.6
P1Sel.7	P1DIR.7	P1DIR.7	P1OUT.7	Out2 signal [†]	P1IN.7	unused	P1IE.7	P1IFG.7	P1IES.7

[†] Signal from or to Timer_A

MSP430C13x1 MIXED SIGNAL MICROCONTROLLER

SLAS341B – SEPTEMBER 2001 – REVISED SEPTEMBER 2004

APPLICATION INFORMATION

input/output schematic (continued)

port P2, P2.0 to P2.2, P2.6, and P2.7 input/output with Schmitt-trigger

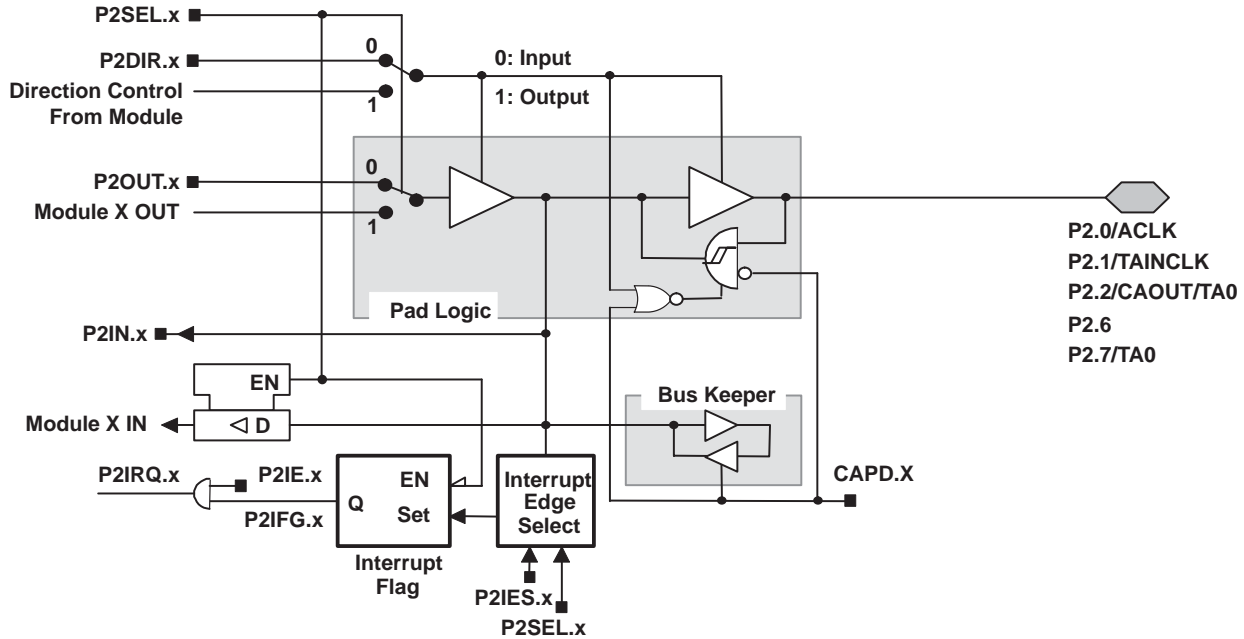

x: Bit Identifier 0 to 2, 6, and 7 for Port P2

PnSel.x	PnDIR.x	Dir. CONTROL FROM MODULE	PnOUT.x	MODULE X OUT	PnIN.x	MODULE X IN	PnIE.x	PnIFG.x	PnIES.x
P2Sel.0	P2DIR.0	P2DIR.0	P2OUT.0	ACLK	P2IN.0	unused	P2IE.0	P2IFG.0	P2IES.0
P2Sel.1	P2DIR.1	P2DIR.1	P2OUT.1	DV _{SS}	P2IN.1	INCLK [†]	P2IE.1	P2IFG.1	P2IES.1
P2Sel.2	P2DIR.2	P2DIR.2	P2OUT.2	CAOUT [†]	P2IN.2	CCI0B [‡]	P2IE.2	P2IFG.2	P2IES.2
P2Sel.6	P2DIR.6	P2DIR.6	P2OUT.6	DV _{SS}	P2IN.6	unused	P2IE.6	P2IFG.6	P2IES.6
P2Sel.7	P2DIR.7	P2DIR.7	P2OUT.7	Out0 signal [§]	P2IN.7	unused	P2IE.7	P2IFG.7	P2IES.7

[†] Signal from Comparator_A

[‡] Signal to Timer_A

[§] Signal from Timer_A

APPLICATION INFORMATION

input/output schematic (continued)

port P2, P2.3 to P2.4, input/output with Schmitt-trigger

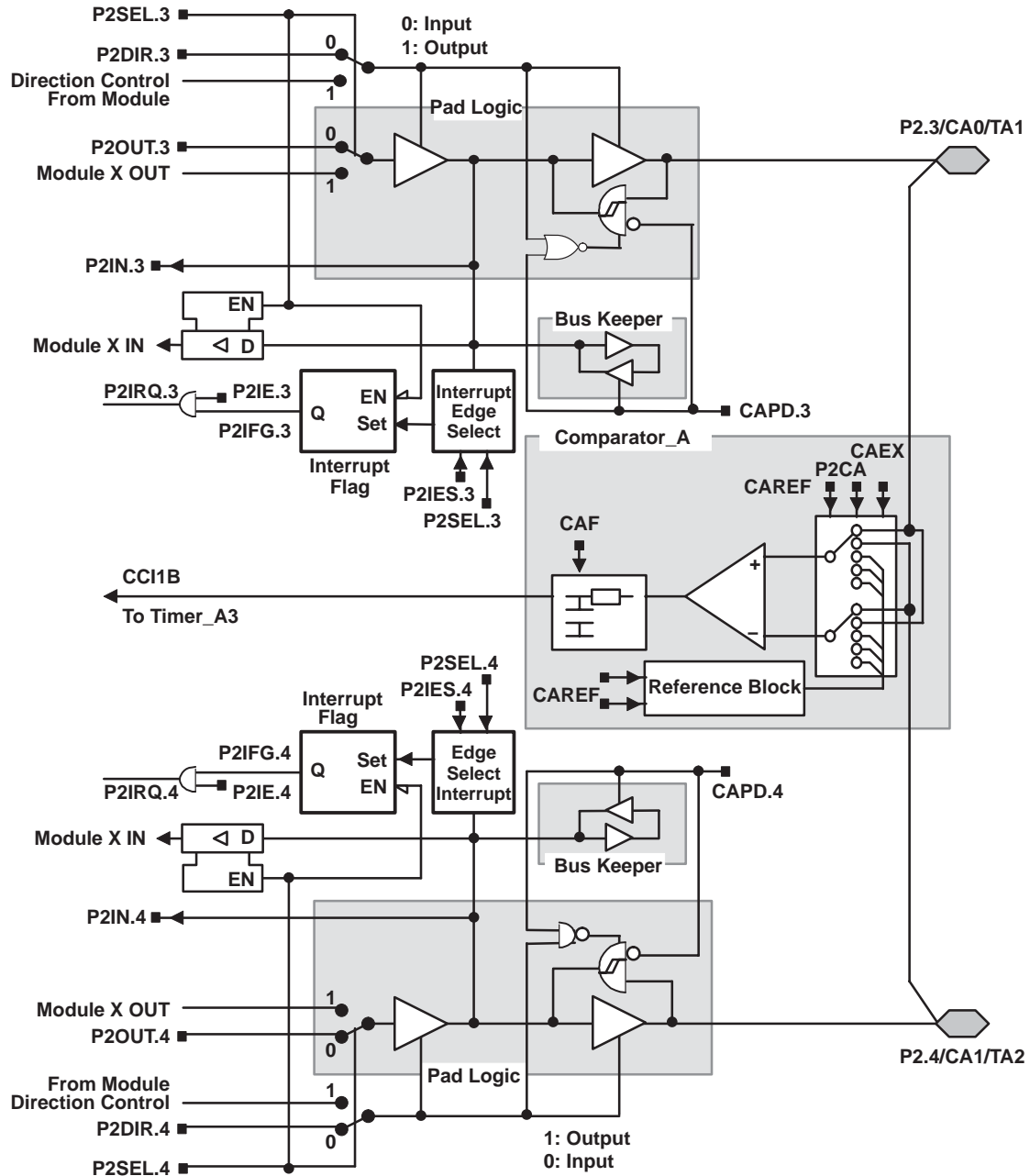

PnSel.x	PnDIR.x	DIRECTION CONTROL FROM MODULE	PnOUT.x	MODULE X OUT	PnIN.x	MODULE X IN	PnIE.x	PnIFG.x	PnIES.x
P2Sel.3	P2DIR.3	P2DIR.3	P2OUT.3	Out1 signal†	P2IN.3	unused	P2IE.3	P2IFG.3	P2IES.3
P2Sel.4	P2DIR.4	P2DIR.4	P2OUT.4	Out2 signal†	P2IN.4	unused	P2IE.4	P2IFG.4	P2IES.4

† Signal from Timer_A

MSP430C13x1 MIXED SIGNAL MICROCONTROLLER

SLAS341B – SEPTEMBER 2001 – REVISED SEPTEMBER 2004

APPLICATION INFORMATION

input/output schematic (continued)

port P2, P2.5, input/output with Schmitt-trigger and R_{OSC} function for the basic clock module

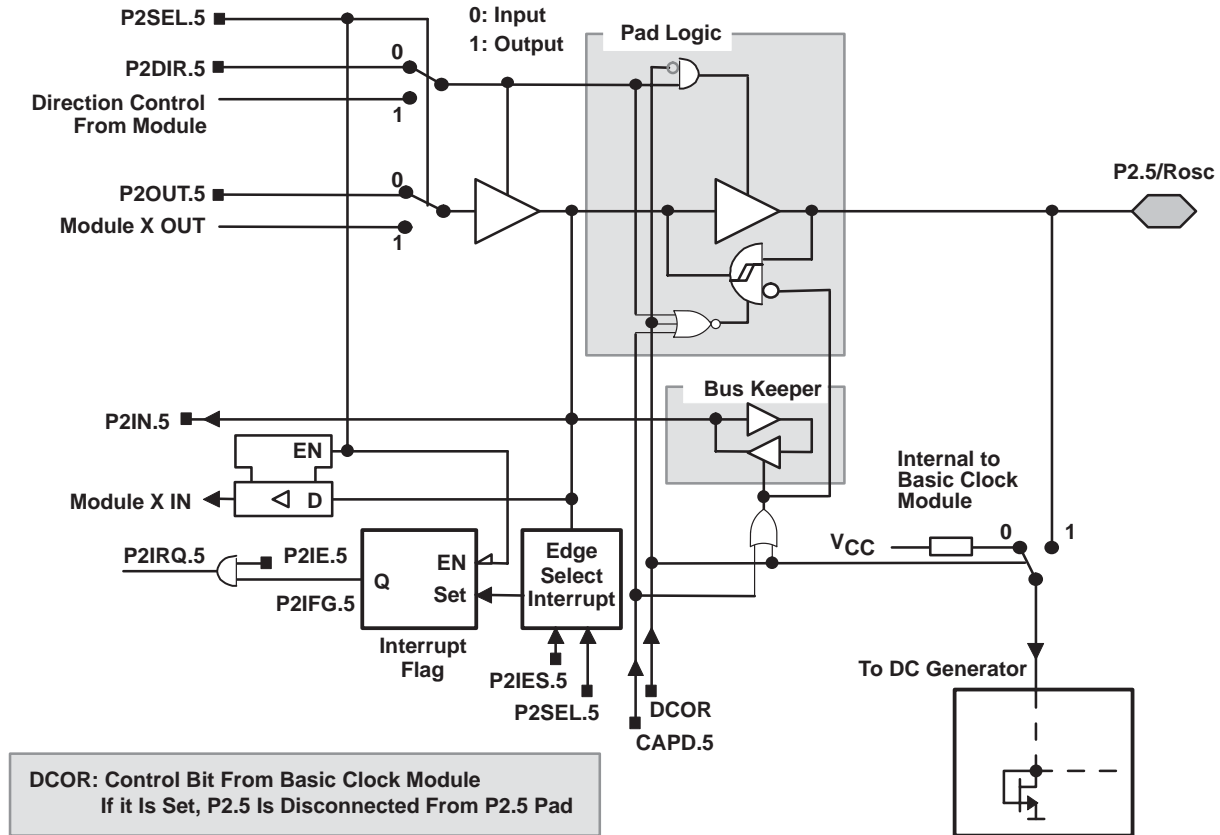

PnSel.x	PnDIR.x	DIRECTION CONTROL FROM MODULE	PnOUT.x	MODULE X OUT	PnIN.x	MODULE X IN	PnIE.x	PnIFG.x	PnIES.x
P2Sel.5	P2DIR.5	P2DIR.5	P2OUT.5	DV _{SS}	P2IN.5	unused	P2IE.5	P2IFG.5	P2IES.5

APPLICATION INFORMATION

input/output schematic (continued)

port P3, P3.0 and P3.4 to P3.7, input/output with Schmitt-trigger

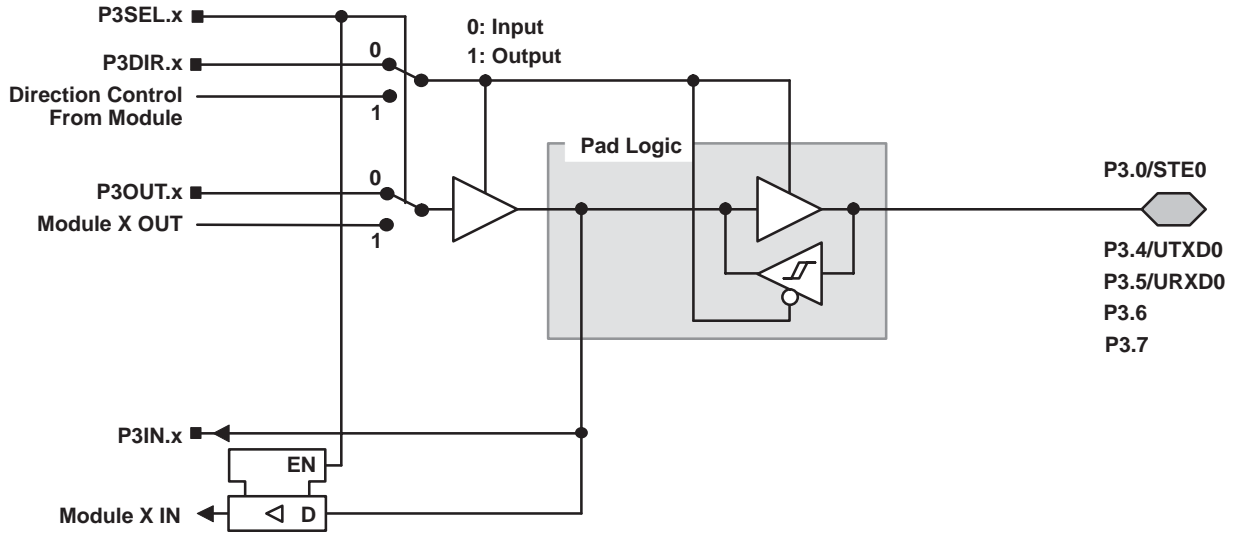

x: Bit Identifier, 0 and 4 to 7 for Port P3

PnSel.x	PnDIR.x	DIRECTION CONTROL FROM MODULE	PnOUT.x	MODULE X OUT	PnIN.x	MODULE X IN
P3Sel.0	P3DIR.0	DV _{SS}	P3OUT.0	DV _{SS}	P3IN.0	STE0
P3Sel.4	P3DIR.4	DV _{CC}	P3OUT.4	UTXD0†	P3IN.4	Unused
P3Sel.5	P3DIR.5	DV _{SS}	P3OUT.5	DV _{SS}	P3IN.5	URXD0‡
P3Sel.6	P3DIR.6	DV _{CC}	P3OUT.6	DV _{SS}	P3IN.6	Unused
P3Sel.7	P3DIR.7	DV _{SS}	P3OUT.7	DV _{SS}	P3IN.7	Unused

† Output from USART0 module

‡ Input to USART0 module

port P3, P3.1, input/output with Schmitt-trigger

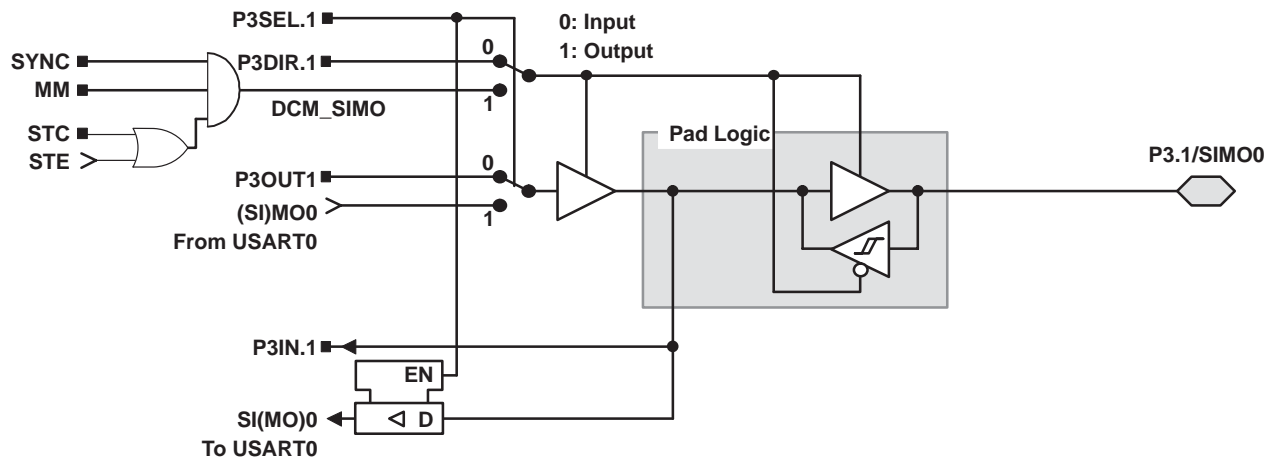

MSP430C13x1 MIXED SIGNAL MICROCONTROLLER

SLAS341B – SEPTEMBER 2001 – REVISED SEPTEMBER 2004

APPLICATION INFORMATION

input/output schematic (continued)

port P3, P3.2, input/output with Schmitt-trigger

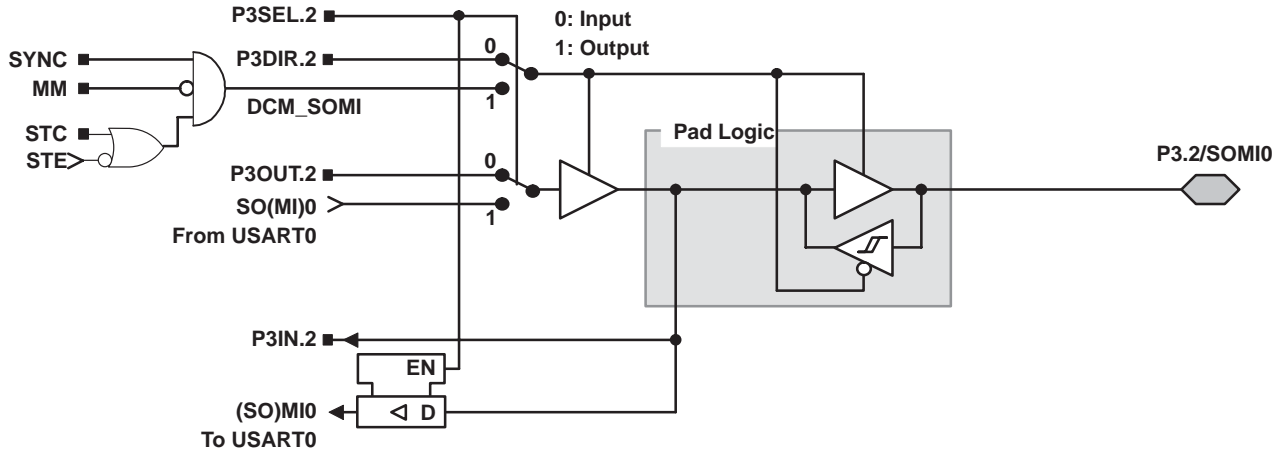

port P3, P3.3, input/output with Schmitt-trigger

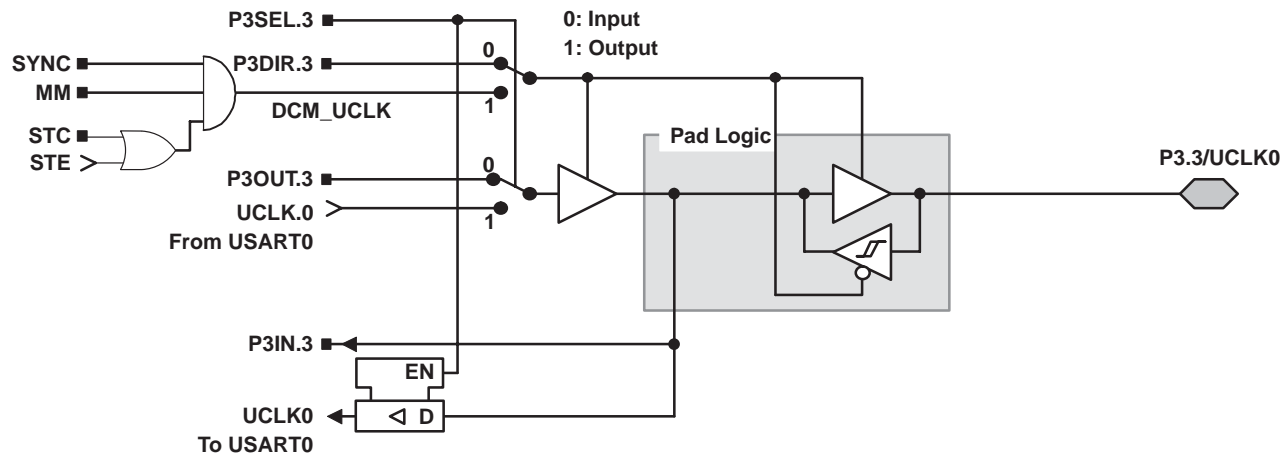

NOTE: UART mode: The UART clock can only be an input. If UART mode and UART function are selected, the P3.3/UCLK0 is always an input.
 SPI, slave mode: The clock applied to UCLK0 is used to shift data in and out.
 SPI, master mode: The clock to shift data in and out is supplied to connected devices on pin P3.3/UCLK0 (in slave mode).

APPLICATION INFORMATION

input/output schematic (continued)

port P4, P4.0 to P4.6, input/output with Schmitt-trigger

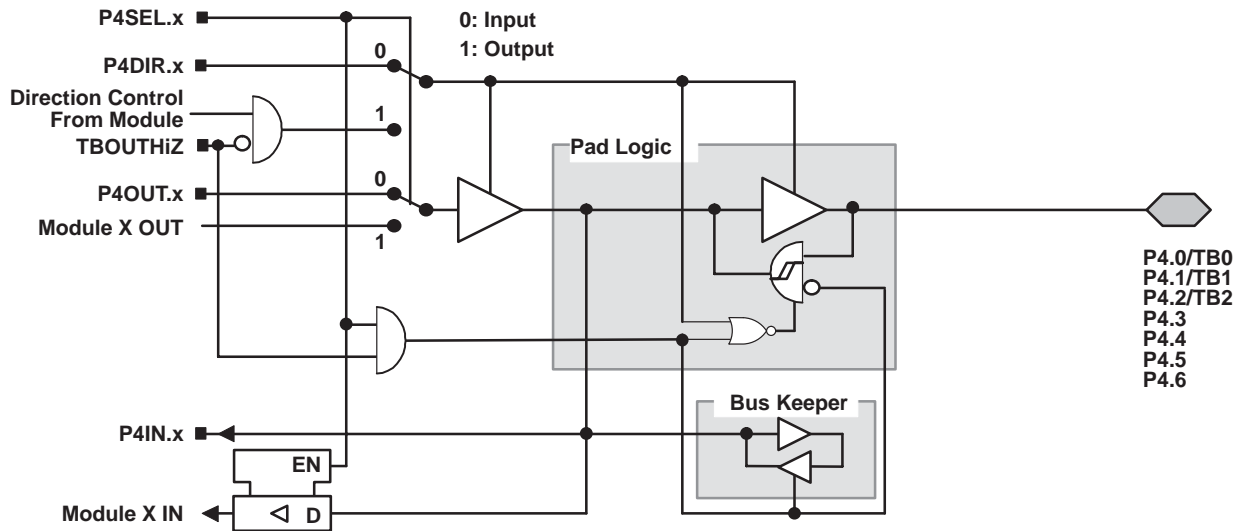

x: bit identifier, 0 to 6 for Port P4

PnSel.x	PnDIR.x	DIRECTION CONTROL FROM MODULE	PnOUT.x	MODULE X OUT	PnIN.x	MODULE X IN
P4Sel.0	P4DIR.0	P4DIR.0	P4OUT.0	Out0 signal [†]	P4IN.0	CCI0A / CCI0B [‡]
P4Sel.1	P4DIR.1	P4DIR.1	P4OUT.1	Out1 signal [†]	P4IN.1	CCI1A / CCI1B [‡]
P4Sel.2	P4DIR.2	P4DIR.2	P4OUT.2	Out2 signal [†]	P4IN.2	CCI2A / CCI2B [‡]
P4Sel.3	P4DIR.3	P4DIR.3	P4OUT.3	DVSS	P4IN.3	Unused
P4Sel.4	P4DIR.4	P4DIR.4	P4OUT.4	DVSS	P4IN.4	Unused
P4Sel.5	P4DIR.5	P4DIR.5	P4OUT.5	DVSS	P4IN.5	Unused
P4Sel.6	P4DIR.6	P4DIR.6	P4OUT.6	DVSS	P4IN.6	Unused

[†] Signal from Timer_B

[‡] Signal to Timer_B

NOTE: TBoutHiZ signal is used by port module P4, pins P4.0 to P4.6. The function TBoutHiZ is mainly used with Timer_B. Port pins P4.3 to P4.6 have the TBoutHiZ function, but no Timer_B output is available for secondary functions. The port selection function can be used to get the port pin to high impedance and to use the P4DIR.x bits.

MSP430C13x1 MIXED SIGNAL MICROCONTROLLER

SLAS341B – SEPTEMBER 2001 – REVISED SEPTEMBER 2004

APPLICATION INFORMATION

input/output schematic (continued)

port P4, P4.7, input/output with Schmitt-trigger

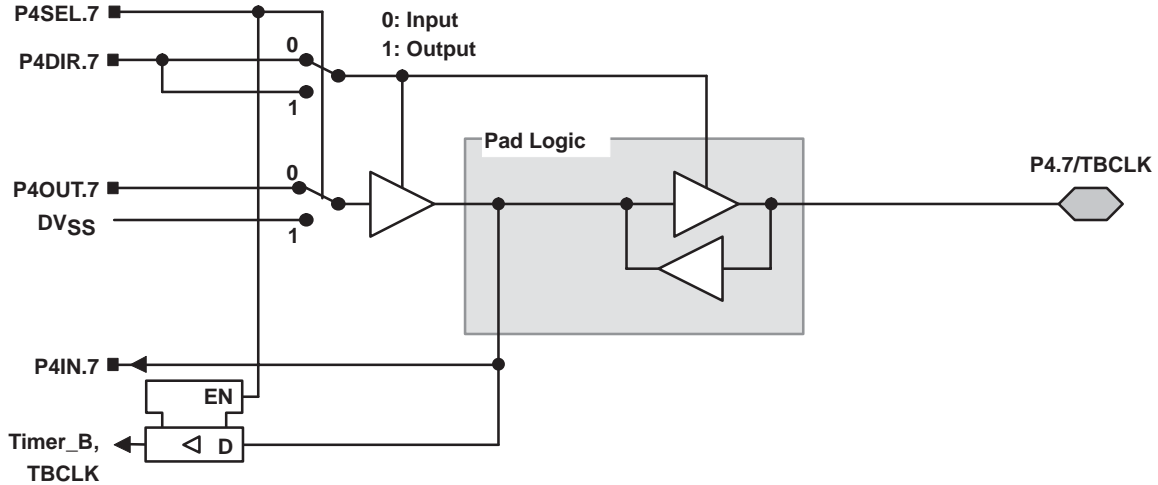

port P5, P5.0 to P5.7, input/output with Schmitt-trigger

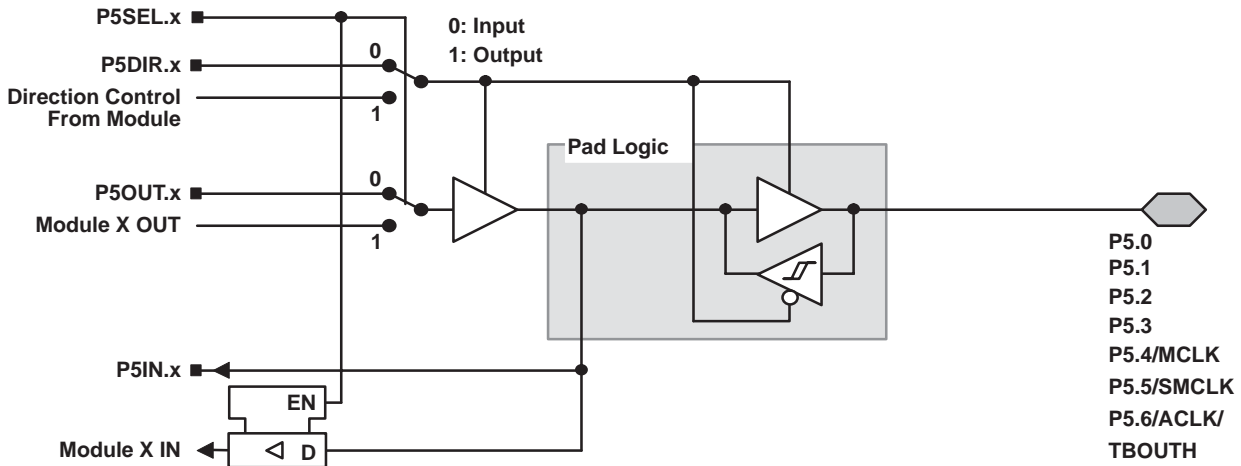

x: Bit Identifier, 0 to 7 for Port P5

PnSel.x	PnDIR.x	Dir. CONTROL FROM MODULE	PnOUT.x	MODULE X OUT	PnIN.x	MODULE X IN
P5Sel.0	P5DIR.0	DVSS	P5OUT.0	DVSS	P5IN.0	unused
P5Sel.1	P5DIR.1	DVCC	P5OUT.1	DVSS	P5IN.1	unused
P5Sel.2	P5DIR.2	DVCC	P5OUT.2	DVSS	P5IN.2	unused
P5Sel.3	P5DIR.3	DVCC	P5OUT.3	DVSS	P5IN.3	unused
P5Sel.4	P5DIR.4	DVCC	P5OUT.4	MCLK	P5IN.4	unused
P5Sel.5	P5DIR.5	DVCC	P5OUT.5	SMCLK	P5IN.5	unused
P5Sel.6	P5DIR.6	DVCC	P5OUT.6	ACLK	P5IN.6	unused
P5Sel.7	P5DIR.7	DVSS	P5OUT.7	DVSS	P5IN.7	TBOUTHiZ

NOTE: TBOUTHiZ signal is used by port module P4, pins P4.0 to P4.6. The function of TBOUTHiZ is mainly useful when used with Timer_B.

APPLICATION INFORMATION

input/output schematic (continued)

port P6, P6.0 to P6.7, input/output with Schmitt-trigger

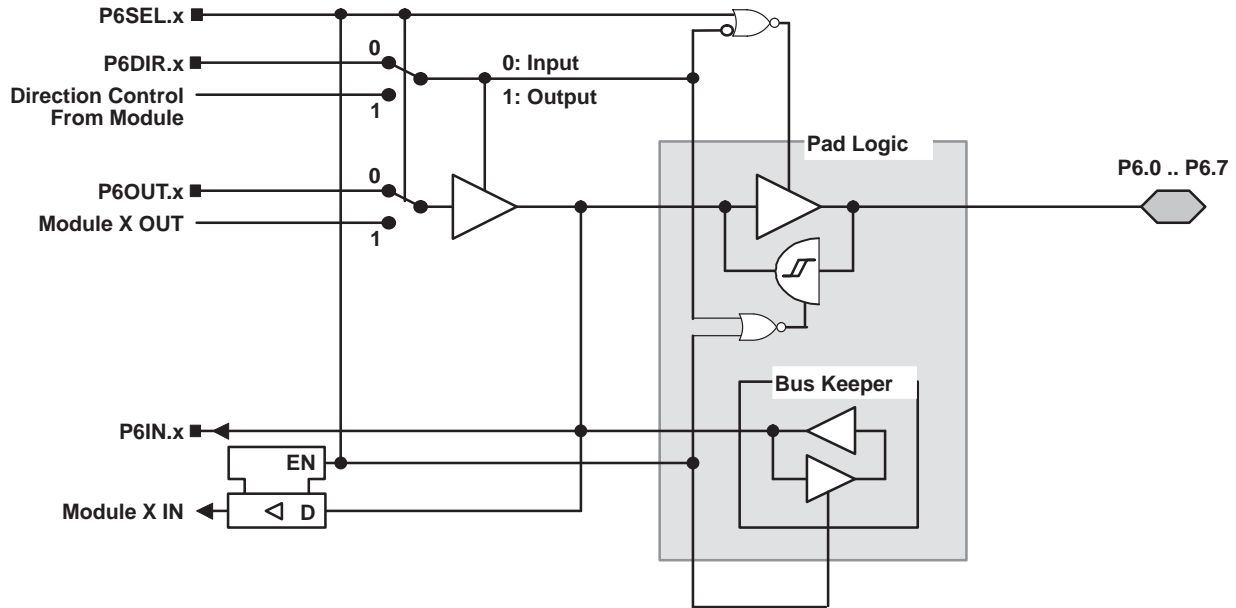

x: Bit Identifier, 0 to 7 for Port P6

PnSel.x	PnDIR.x	DIR. CONTROL FROM MODULE	PnOUT.x	MODULE X OUT	PnIN.x	MODULE X IN
P6Sel.0	P6DIR.0	P6DIR.0	P6OUT.0	DV _{SS}	P6IN.0	unused
P6Sel.1	P6DIR.1	P6DIR.1	P6OUT.1	DV _{SS}	P6IN.1	unused
P6Sel.2	P6DIR.2	P6DIR.2	P6OUT.2	DV _{SS}	P6IN.2	unused
P6Sel.3	P6DIR.3	P6DIR.3	P6OUT.3	DV _{SS}	P6IN.3	unused
P6Sel.4	P6DIR.4	P6DIR.4	P6OUT.4	DV _{SS}	P6IN.4	unused
P6Sel.5	P6DIR.5	P6DIR.5	P6OUT.5	DV _{SS}	P6IN.5	unused
P6Sel.6	P6DIR.6	P6DIR.6	P6OUT.6	DV _{SS}	P6IN.6	unused
P6Sel.7	P6DIR.7	P6DIR.7	P6OUT.7	DV _{SS}	P6IN.7	unused

NOTE: Direction control bits P6DIR.x and P6SEL.x control whether the port function is active (P6DIR.x=0) or whether the input P6.x is in the high-impedance state. This is identical to the port P6 function in the MSP430F13x devices (used for emulation/prototyping), but different from other digital-only ports such as P5.

MSP430C13x1 MIXED SIGNAL MICROCONTROLLER

SLAS341B – SEPTEMBER 2001 – REVISED SEPTEMBER 2004

APPLICATION INFORMATION

JTAG pins TMS, TCK, TDI, TDO/TDI, input/output with Schmitt-trigger

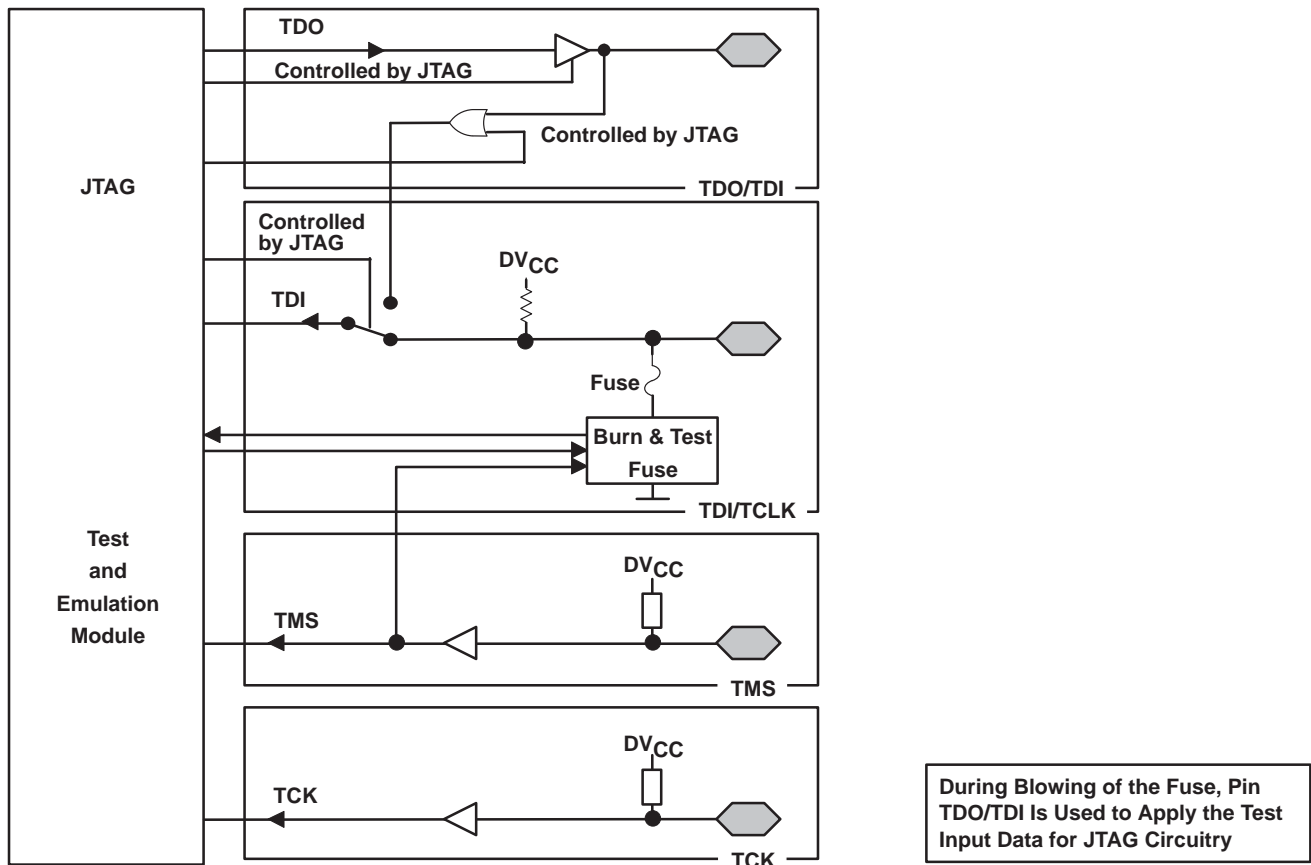

JTAG fuse check mode

MSP430 devices that have the fuse on the TDI/TCLK terminal have a fuse check mode that tests the continuity of the fuse the first time the JTAG port is accessed after a power-on reset (POR). When activated, a fuse check current, I_{TF} , of 1 mA at 3 V can flow from the TDI/TCLK pin to ground if the fuse is not burned. Care must be taken to avoid accidentally activating the fuse check mode and increasing overall system power consumption.

Activation of the fuse check mode occurs with the first negative edge on the TMS pin after power up or if the TMS is being held low during power up. The second positive edge on the TMS pin deactivates the fuse check mode. After deactivation, the fuse check mode remains inactive until another POR occurs. After each POR the fuse check mode has the potential to be activated.

The fuse check current will only flow when the fuse check mode is active and the TMS pin is in a low state (see Figure 13). Therefore, the additional current flow can be prevented by holding the TMS pin high (default condition).

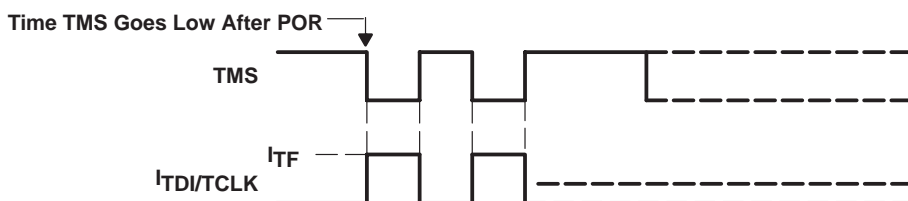

Figure 13. Fuse Check Mode Current

IMPORTANT NOTICE

Texas Instruments Incorporated and its subsidiaries (TI) reserve the right to make corrections, modifications, enhancements, improvements, and other changes to its products and services at any time and to discontinue any product or service without notice. Customers should obtain the latest relevant information before placing orders and should verify that such information is current and complete. All products are sold subject to TI's terms and conditions of sale supplied at the time of order acknowledgment.

TI warrants performance of its hardware products to the specifications applicable at the time of sale in accordance with TI's standard warranty. Testing and other quality control techniques are used to the extent TI deems necessary to support this warranty. Except where mandated by government requirements, testing of all parameters of each product is not necessarily performed.

TI assumes no liability for applications assistance or customer product design. Customers are responsible for their products and applications using TI components. To minimize the risks associated with customer products and applications, customers should provide adequate design and operating safeguards.

TI does not warrant or represent that any license, either express or implied, is granted under any TI patent right, copyright, mask work right, or other TI intellectual property right relating to any combination, machine, or process in which TI products or services are used. Information published by TI regarding third-party products or services does not constitute a license from TI to use such products or services or a warranty or endorsement thereof. Use of such information may require a license from a third party under the patents or other intellectual property of the third party, or a license from TI under the patents or other intellectual property of TI.

Reproduction of information in TI data books or data sheets is permissible only if reproduction is without alteration and is accompanied by all associated warranties, conditions, limitations, and notices. Reproduction of this information with alteration is an unfair and deceptive business practice. TI is not responsible or liable for such altered documentation.

Resale of TI products or services with statements different from or beyond the parameters stated by TI for that product or service voids all express and any implied warranties for the associated TI product or service and is an unfair and deceptive business practice. TI is not responsible or liable for any such statements.

Following are URLs where you can obtain information on other Texas Instruments products and application solutions:

Products		Applications	
Amplifiers	amplifier.ti.com	Audio	www.ti.com/audio
Data Converters	dataconverter.ti.com	Automotive	www.ti.com/automotive
DSP	dsp.ti.com	Broadband	www.ti.com/broadband
Interface	interface.ti.com	Digital Control	www.ti.com/digitalcontrol
Logic	logic.ti.com	Military	www.ti.com/military
Power Mgmt	power.ti.com	Optical Networking	www.ti.com/opticalnetwork
Microcontrollers	microcontroller.ti.com	Security	www.ti.com/security
		Telephony	www.ti.com/telephony
		Video & Imaging	www.ti.com/video
		Wireless	www.ti.com/wireless

Mailing Address: Texas Instruments
Post Office Box 655303 Dallas, Texas 75265