

FAIRCHILD
SEMICONDUCTOR®

14mm (0.56 inch) Four Digit CLOCK STICK DISPLAY

Bright Red MSQC6110W, MSQC6140W
High Efficiency Red MSQC6910W, MSQC6940W
Green MSQC6410W, MSQC6440W

PACKAGE DIMENSIONS

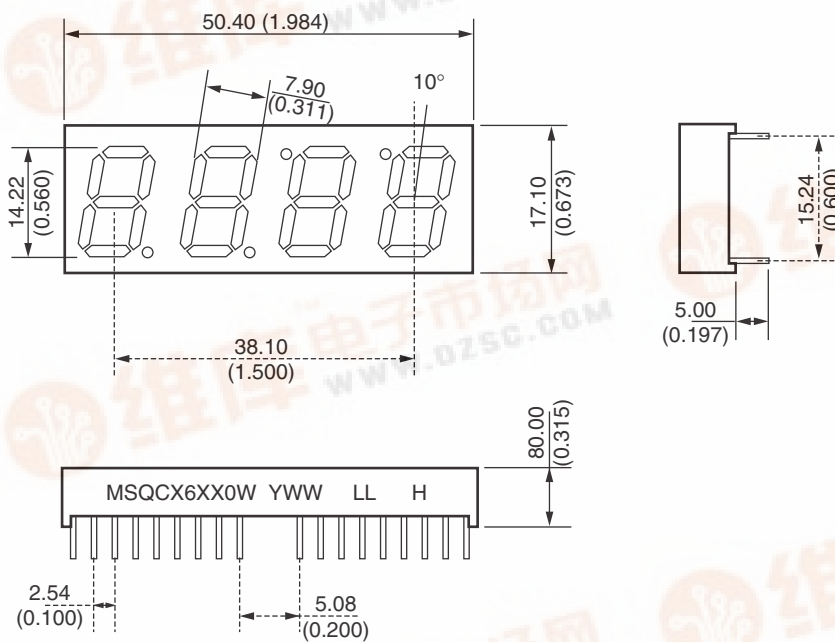

Notes:

- Dimensions are in mm (inches)
- All pins 0.5mm (0.020") diameter
- Tolerances are ±0.25mm (0.010") unless otherwise stated

Features

- Bright Bold Segments
- Common Anode/Cathode
- Low Power Consumption
- Low Current Capability
- Epoxy Encapsulated PCB
- High Performance
- High Reliability

Applications

- Appliances
- Automotive
- Instrumentation
- Process Control

MODELS AVAILABLE

Part Number	Color	Description
MSQC6110W	Bright Red	Clock Display, Common Anode – gray face, neutral segments
MSQC6140W	Bright Red	Clock Display, Common Cathode – gray face, neutral segments
MSQC6410W	Green	Clock Display, Common Anode – gray face, green segments
MSQC6440W	Green	Clock Display, Common Cathode – gray face, green segments
MSQC6910W	High Efficiency Red	Clock Display, Common Anode – gray face, neutral segments
MSQC6940W	High Efficiency Red	Clock Display, Common Cathode – gray face, neutral segments

14mm (0.56 inch) Four Digit CLOCK STICK DISPLAY

Bright Red MSQC6110W, MSQC6140W
High Efficiency Red MSQC6910W, MSQC6940W
Green MSQC6410W, MSQC6440W

ABSOLUTE MAXIMUM RATINGS⁽¹⁾ (T_A = 25°C, unless otherwise specified)

Part Number Parameter	MSQC6110W MSQC6140W	MSQC6410W MSQC6440W	MSQC6910W MSQC6940W	Units
Continuous Forward Current (each segment)	15	25	25	mA
Peak Forward Current (F = 10KHz, D/F = 1/10)	60	90	90	mA
Power Dissipation (P _D)	40	70	70	mW
*Derate Linearly from 25°C	0.17	0.33	0.33	mW
Reverse Voltage per Die	5 Volts			
Operating and Storage Temperature Range	-40°C to +85°C			
Lead soldering time (1/16 inch from standoffs)	5 seconds @ 230°C			

ELECTRO-OPTICAL CHARACTERISTICS⁽¹⁾ (T_A = 25°C, unless otherwise specified)

Part Number Parameter	MSQC6110W MSQC6140W	MSQC6410W MSQC6440W	MSQC6910W MSQC6910W	Units	Test Condition
Luminous intensity ⁽²⁾ (I _V)					
Minimum (Standard Current)	300	800	800	μcd	I _F = 10mA
Typical (Standard Current)	700	2400	2000	μcd	I _F = 10mA
Minimum (Low Current)	Not Available				
Typical (Low Current)	Not Available				
Forward Voltage (V _F)					
Typical (Standard Current)	2.10	2.10	2.00	V	I _F = 20mA
Maximum (Standard Current)	2.80	2.80	2.80	V	I _F = 20mA
Typical (Low Current)	Not Available				
Maximum (Low Current)	Not Available				
Peak Wavelength	695	570	635	nm	I _F = 20mA
Dominant Wavelength	Not Available				
Spectral Line 1/2 Width	90	30	45	nm	I _F = 10mA
Reverse B ⁽³⁾ . Voltage (V _R)	5	5	5	V	I _R = 100μA

NOTES:

(1) Data per individual LED element

(2) Luminous intensity (μcd) = average light output per segment

(3) B = breakdown

14mm (0.56 inch) Four Digit CLOCK STICK DISPLAY

Bright Red MSQC6110W, MSQC6140W
High Efficiency Red MSQC6910W, MSQC6940W
Green MSQC6410W, MSQC6440W

PIN ORIENTATION, SEGMENT IDENTIFICATION, AND PRODUCT MARKING

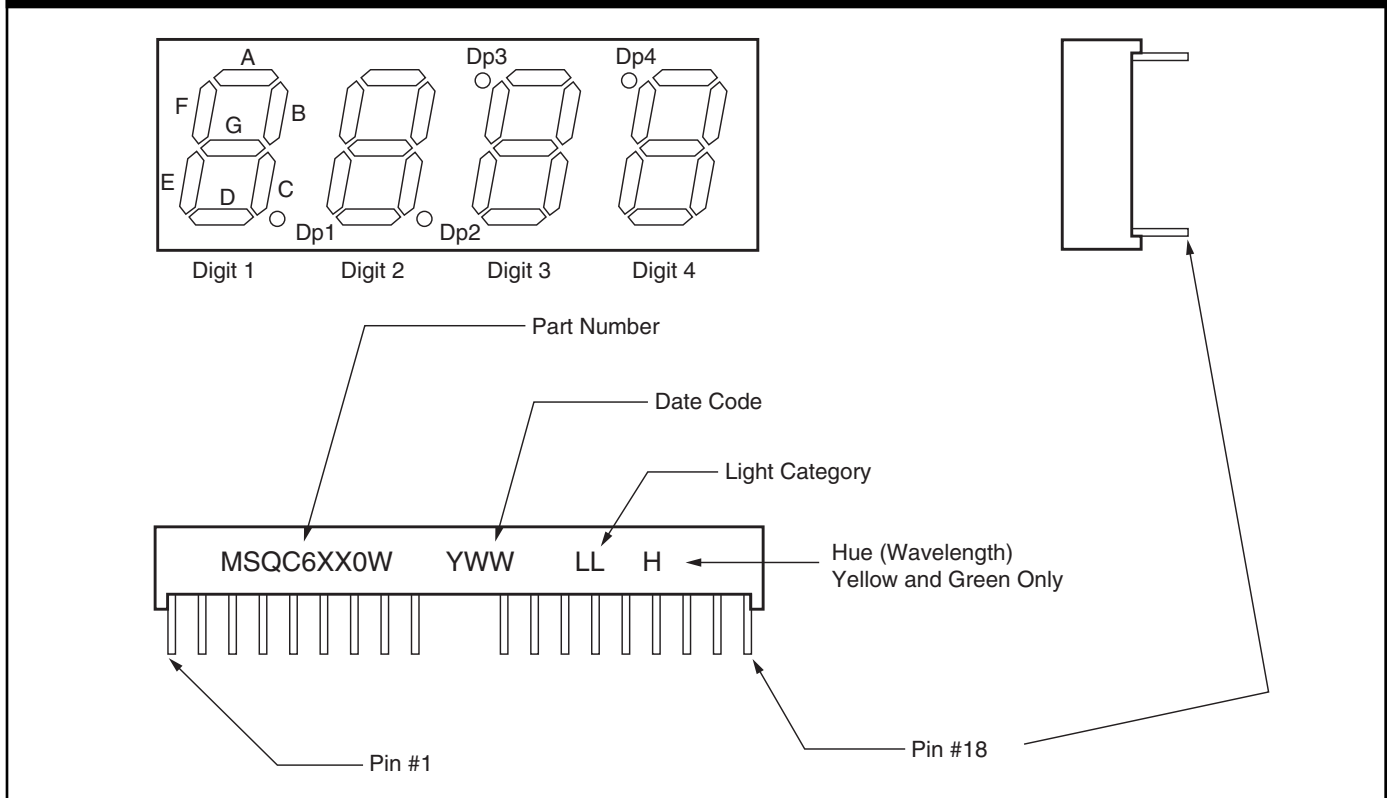

SCHEMATICS

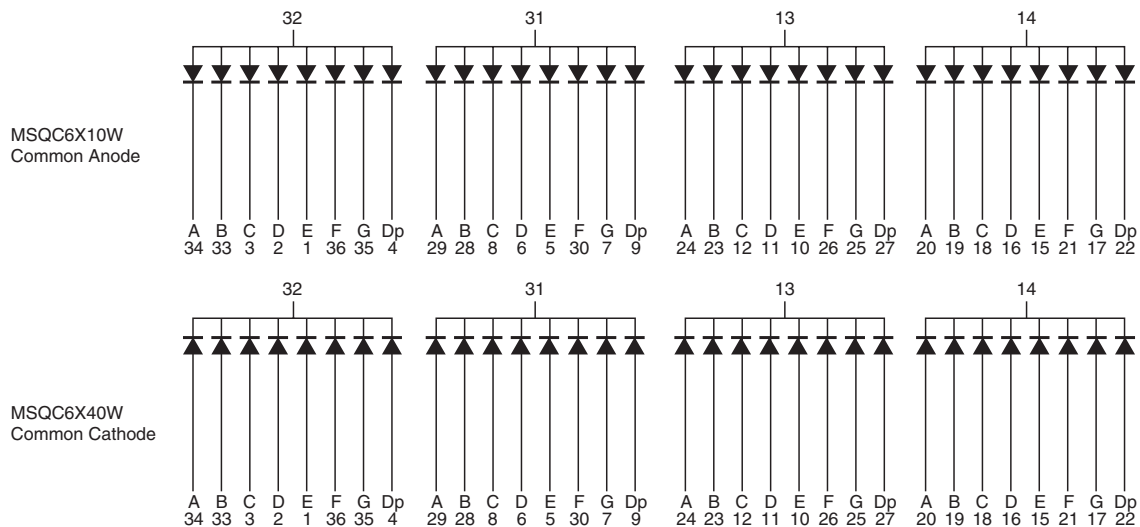

**Bright Red MSQC6110W, MSQC6140W
High Efficiency Red MSQC6910W, MSQC6940W
Green MSQC6410W, MSQC6440W**

GRAPHICAL DATA Bright Red ($T_A = 25^\circ\text{C}$, unless otherwise specified)

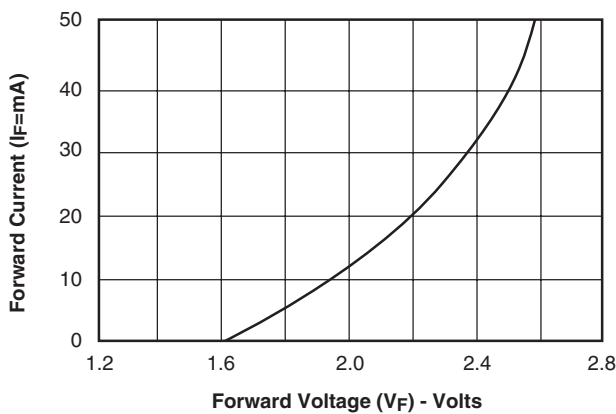

Fig. 1 Forward Current vs. Forward Voltage

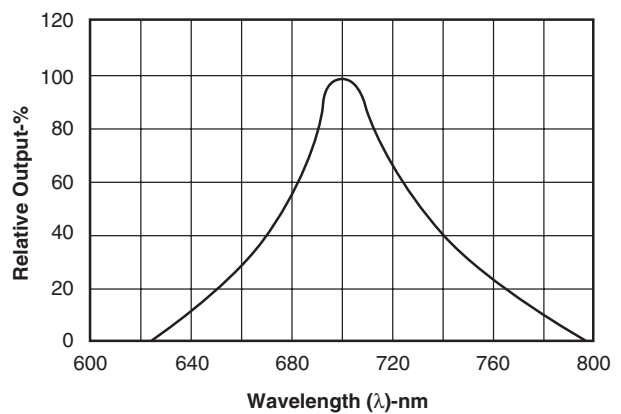

Fig. 2 Spectral Response

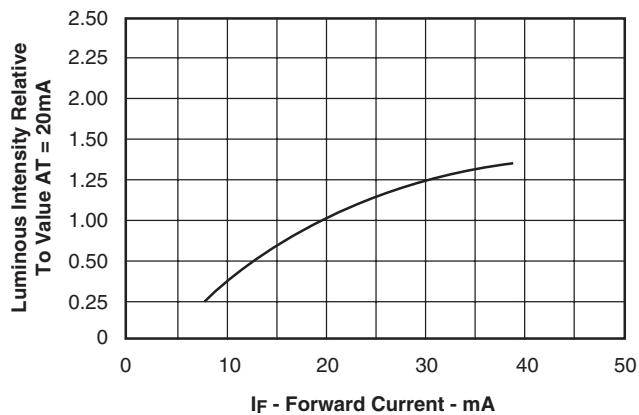

Fig. 3 Relative Luminous Intensity vs. Forward Current

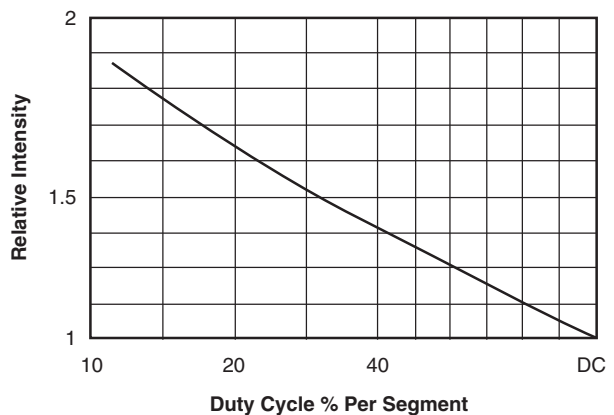

Fig. 5 Luminous Intensity vs. Duty Cycle

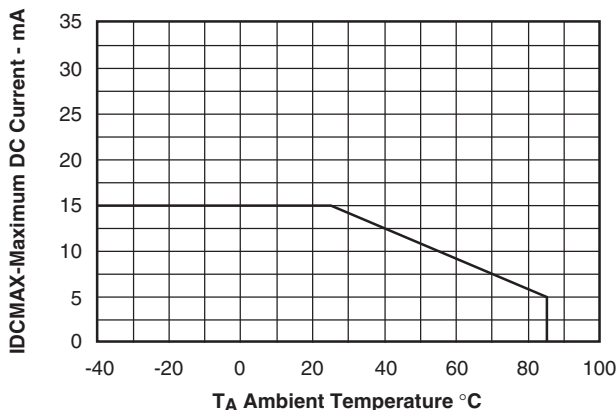

Fig. 4 Maximum Allowable DC Current per Segment vs. a Function of Ambient Temperature

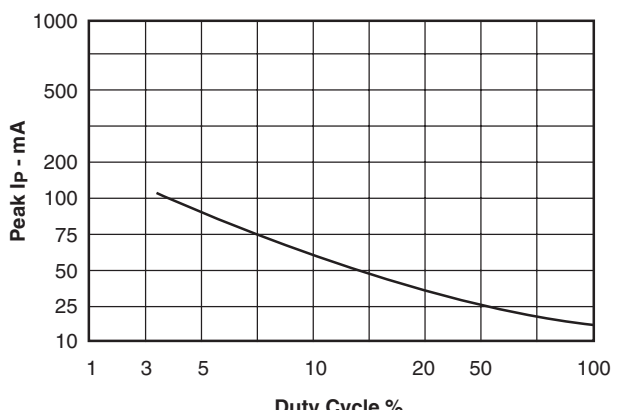

Fig. 6 Max Peak Current vs. Duty Cycle % (Refresh Rate f=1 KHz)

Bright Red MSQC6110W, MSQC6140W
High Efficiency Red MSQC6910W, MSQC6940W
Green MSQC6410W, MSQC6440W

GRAPHICAL DATA Green ($T_A = 25^\circ\text{C}$, unless otherwise specified)

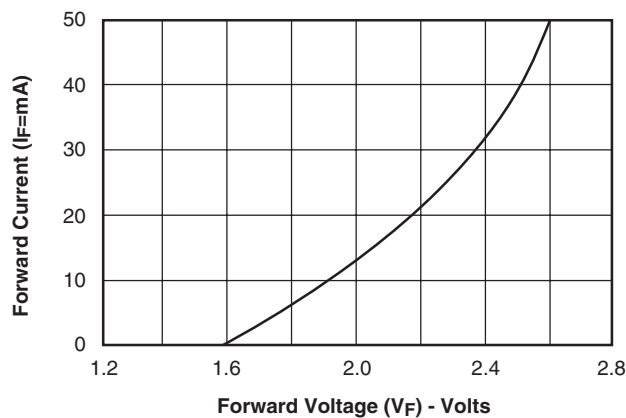

Fig. 1 Forward Current vs. Forward Voltage

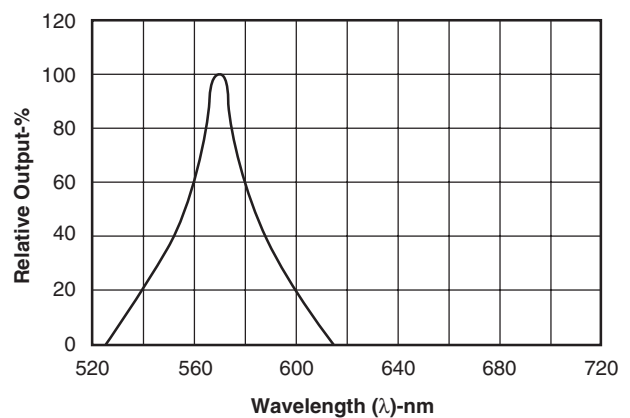

Fig. 2 Spectral Response

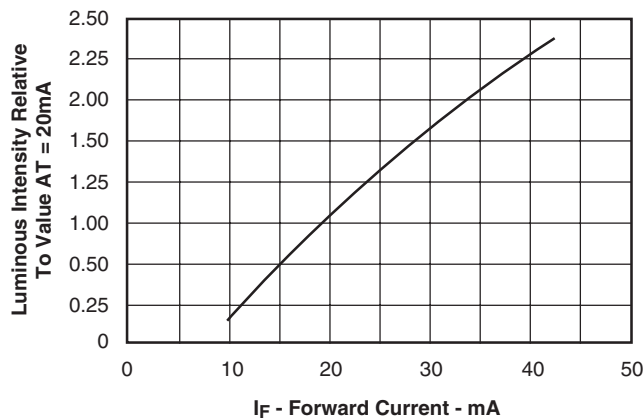

Fig. 3 Relative Luminous Intensity vs. Forward Current

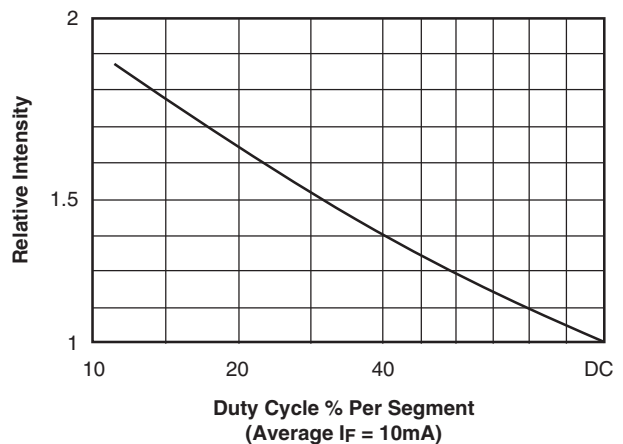

Fig. 5 Luminous Intensity vs. Duty Cycle

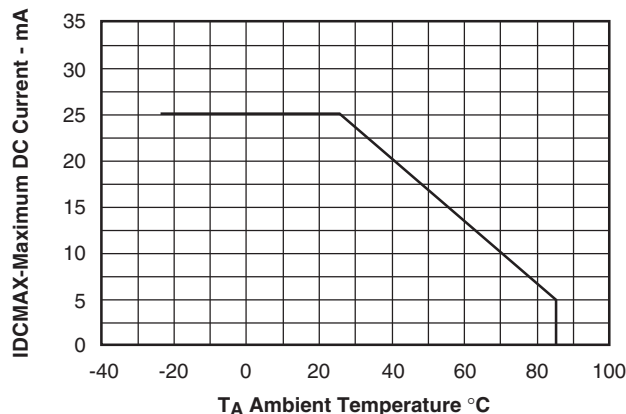

Fig. 4 Maximum Allowable DC Current per Segment vs. a Function of Ambient Temperature

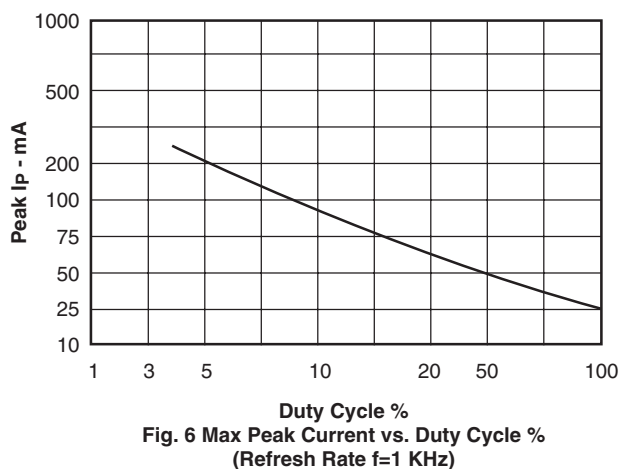

Fig. 6 Max Peak Current vs. Duty Cycle % (Refresh Rate f=1 KHz)

**Bright Red MSQC6110W, MSQC6140W
High Efficiency Red MSQC6910W, MSQC6940W
Green MSQC6410W, MSQC6440W**

GRAPHICAL DATA High Efficiency Red ($T_A = 25^\circ\text{C}$, unless otherwise specified)

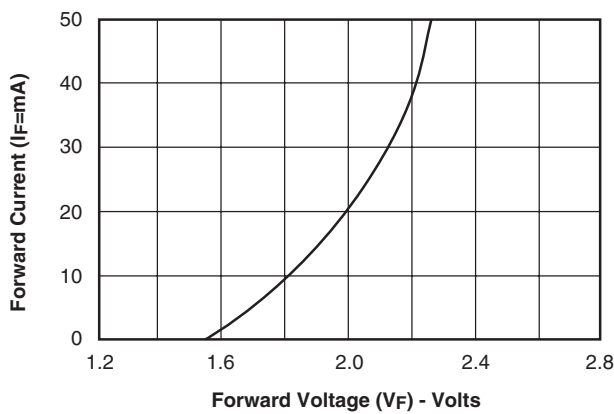

Fig. 1 Forward Current vs. Forward Voltage

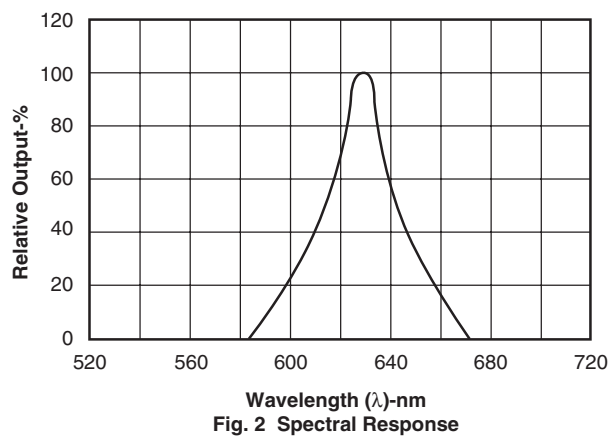

Fig. 2 Spectral Response

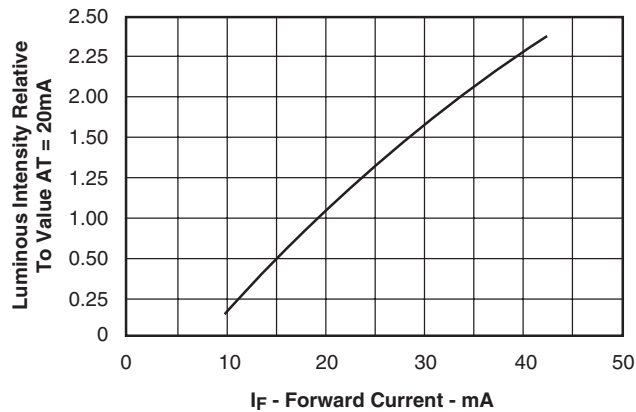

Fig. 3 Relative Luminous Intensity vs. Forward Current

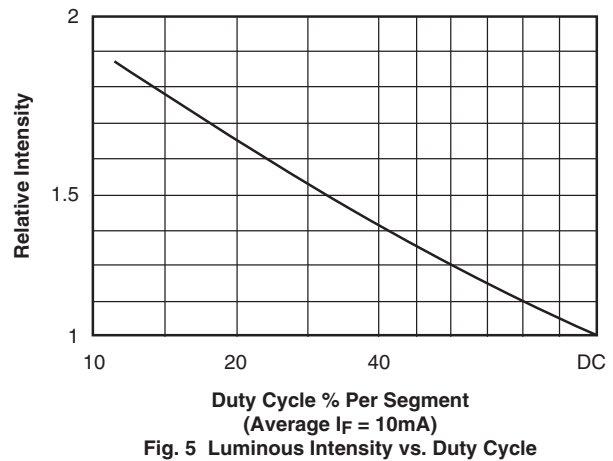

Fig. 5 Luminous Intensity vs. Duty Cycle

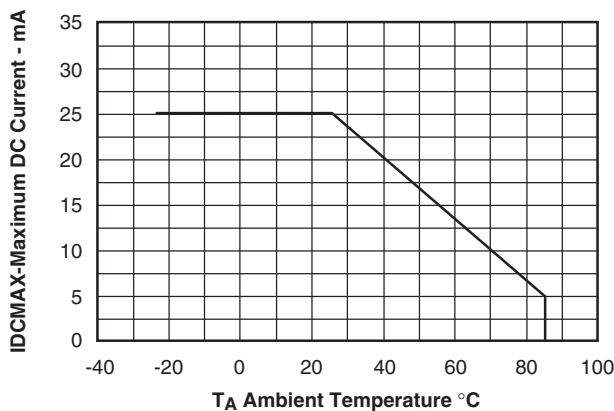

Fig. 4 Maximum Allowable DC Current per Segment vs. a Function of Ambient Temperature

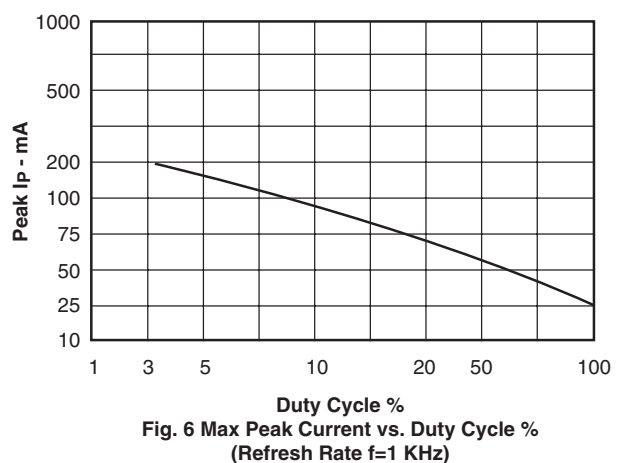

Fig. 6 Max Peak Current vs. Duty Cycle % (Refresh Rate f=1 KHz)



14mm (0.56 inch) Four Digit CLOCK STICK DISPLAY

Bright Red MSQC6110W, MSQC6140W
High Efficiency Red MSQC6910W, MSQC6940W
Green MSQC6410W, MSQC6440W

DISCLAIMER

FAIRCHILD SEMICONDUCTOR RESERVES THE RIGHT TO MAKE CHANGES WITHOUT FURTHER NOTICE TO ANY PRODUCTS HEREIN TO IMPROVE RELIABILITY, FUNCTION OR DESIGN. FAIRCHILD DOES NOT ASSUME ANY LIABILITY ARISING OUT OF THE APPLICATION OR USE OF ANY PRODUCT OR CIRCUIT DESCRIBED HEREIN; NEITHER DOES IT CONVEY ANY LICENSE UNDER ITS PATENT RIGHTS, NOR THE RIGHTS OF OTHERS.

LIFE SUPPORT POLICY

FAIRCHILD'S PRODUCTS ARE NOT AUTHORIZED FOR USE AS CRITICAL COMPONENTS IN LIFE SUPPORT DEVICES OR SYSTEMS WITHOUT THE EXPRESS WRITTEN APPROVAL OF THE PRESIDENT OF FAIRCHILD SEMICONDUCTOR CORPORATION. As used herein:

1. Life support devices or systems are devices or systems which, (a) are intended for surgical implant into the body, or (b) support or sustain life, and (c) whose failure to perform when properly used in accordance with instructions for use provided in the labeling, can be reasonably expected to result in a significant injury of the user.
2. A critical component in any component of a life support device or system whose failure to perform can be reasonably expected to cause the failure of the life support device or system, or to affect its safety or effectiveness.