

5mm Ultra Bright LED 急出货

MT3200A-UR

Applications -

- Optical Sensor
- Indicators

Features -

- High Luminous Intensity
- Narrow Beam Angle

MAXIMUM RATINGS (Ta = 25°C)

CHARACTERISTIC	SYMBOL	RATING	UNIT
Forward Current	I_F	50	mA
Pulse IF*	I_{FP}	.5	A
Reverse Voltage	V_R	4	V
Power Dissipation	P_D	120	mW
Operating Temperature	T_{opr}	-20~80	°C
Storage Temperature	T_{stg}	-30~100	°C
Soldering Temperature**	Tsol	260	°C

*tw=10μS, T=10mS

**Time: 5 sec Max. Position: Up to 2mm from the body

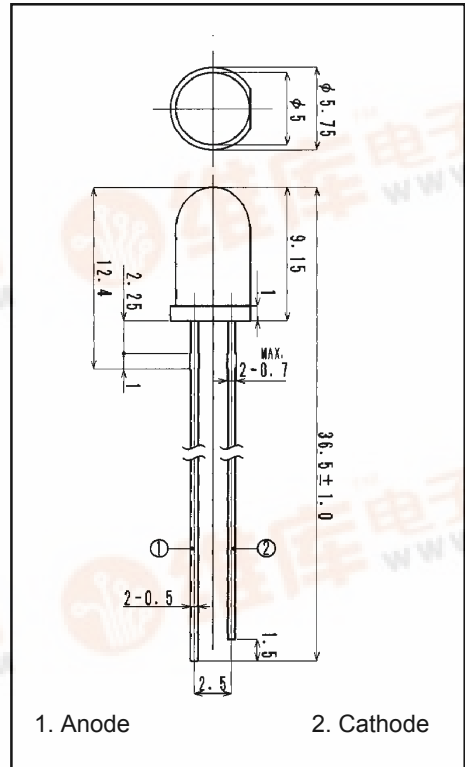

OPTO-ELECTRICAL CHARACTERISTICS (Ta = 25°C)

CHARACTERISTIC	SYMBOL	TEST CONDITION	MIN.	TYP.	MAX.	UNIT
Power Output	PO	IF = 20mA	—	5.0	—	mW
Forward Voltage	V_F	IF = 20mA	—	1.8	2.2	V
Reverse Current	I_R	VR = 4V	—	—	100	μA
Peak Emission Wavelength	λ_p	IF = 20mA	—	660	—	nm
Spectral Line Half Width	$\Delta\lambda$	IF = 20mA	—	25	—	nm
Beam Angle	θ	—	—	±7	—	°



5mm Ultra Bright LED

MT3200A-UR Graphs -

