



MT4C16270
256K x 16 DRAM

DRAM

256K x 16 DRAM

5V, EDO PAGE MODE

FEATURES

- Industry-standard x16 pinouts, timing, functions and packages
- High-performance CMOS silicon-gate process
- Single +5V $\pm 10\%$ power supply*
- Low power, 3mW standby; 300mW active, typical
- All device pins are TTL-compatible
- 512-cycle refresh in 8ms (9 row- and 9 column addresses)
- Refresh modes: RAS#-ONLY, CAS#-BEFORE-RAS# (CBR) and HIDDEN
- Extended Data-Out (EDO) PAGE MODE access cycle
- BYTE WRITE and BYTE READ access cycles

OPTIONS

- Timing
 - 40ns access
 - 50ns access
 - 60ns access
- Packages
 - Plastic SOJ (400 mil)

MARKING

-4*
-5*
-6

DJ

- Part Number Example: MT4C16270DJ-4

*40ns and 50ns access specifications are limited to a Vcc range of $\pm 5\%$. Contact factory for availability.

KEY TIMING PARAMETERS

| SPEED | t _{RC} | t _{RAC} | t _{PC} | t _{AA} | t _{CAC} | t _{CAS} | t _{CP} |
|-------|-----------------|------------------|-----------------|-----------------|------------------|------------------|-----------------|
| -4 | 75ns | 40ns | 15ns | 20ns | 12ns | 6ns | 6ns |
| -5 | 100ns | 50ns | 20ns | 25ns | 15ns | 8ns | 8ns |
| -6 | 110ns | 60ns | 25ns | 30ns | 15ns | 10ns | 10ns |

PIN ASSIGNMENT (Top View)

40-Pin SOJ (DA-6)

| | | | |
|------|----|----|-------|
| Vcc | 1 | 40 | Vss |
| DQ1 | 2 | 39 | DQ16 |
| DQ2 | 3 | 38 | DQ15 |
| DQ3 | 4 | 37 | DQ14 |
| DQ4 | 5 | 36 | DQ13 |
| Vcc | 6 | 35 | Vss |
| DQ5 | 7 | 34 | DQ12 |
| DQ6 | 8 | 33 | DQ11 |
| DQ7 | 9 | 32 | DQ10 |
| DQ8 | 10 | 31 | DQ9 |
| NC | 11 | 30 | NC |
| NC | 12 | 29 | CASL# |
| WE# | 13 | 28 | CASH# |
| RAS# | 14 | 27 | OE# |
| NC | 15 | 26 | A8 |
| A0 | 16 | 25 | A7 |
| A1 | 17 | 24 | A6 |
| A2 | 18 | 23 | A5 |
| A3 | 19 | 22 | A4 |
| Vcc | 20 | 21 | Vss |

GENERAL DESCRIPTION

The MT4C16270 is a randomly accessed solid-state memory containing 4,194,304 bits organized in a x16 configuration. The MT4C16270 has both BYTE WRITE and WORD WRITE access cycles via two CAS# pins.

The MT4C16270 CAS# function and timing are determined by the first CAS# (CASL# or CASH#) to transition LOW and by the last to transition back HIGH. CASL# and CASH# function in a similar manner to CAS# in that either

CASL# or CASH# will generate an internal CAS#. Use of only one of the two results in a BYTE WRITE cycle. CASL# transitioning LOW selects a WRITE cycle for the lower byte (DQ1-DQ8) and CASH# transitioning LOW selects a WRITE cycle for the upper byte (DQ9-DQ16). BYTE READ cycles are achieved through CASL# or CASH# in the same manner.

FUNCTIONAL BLOCK DIAGRAM

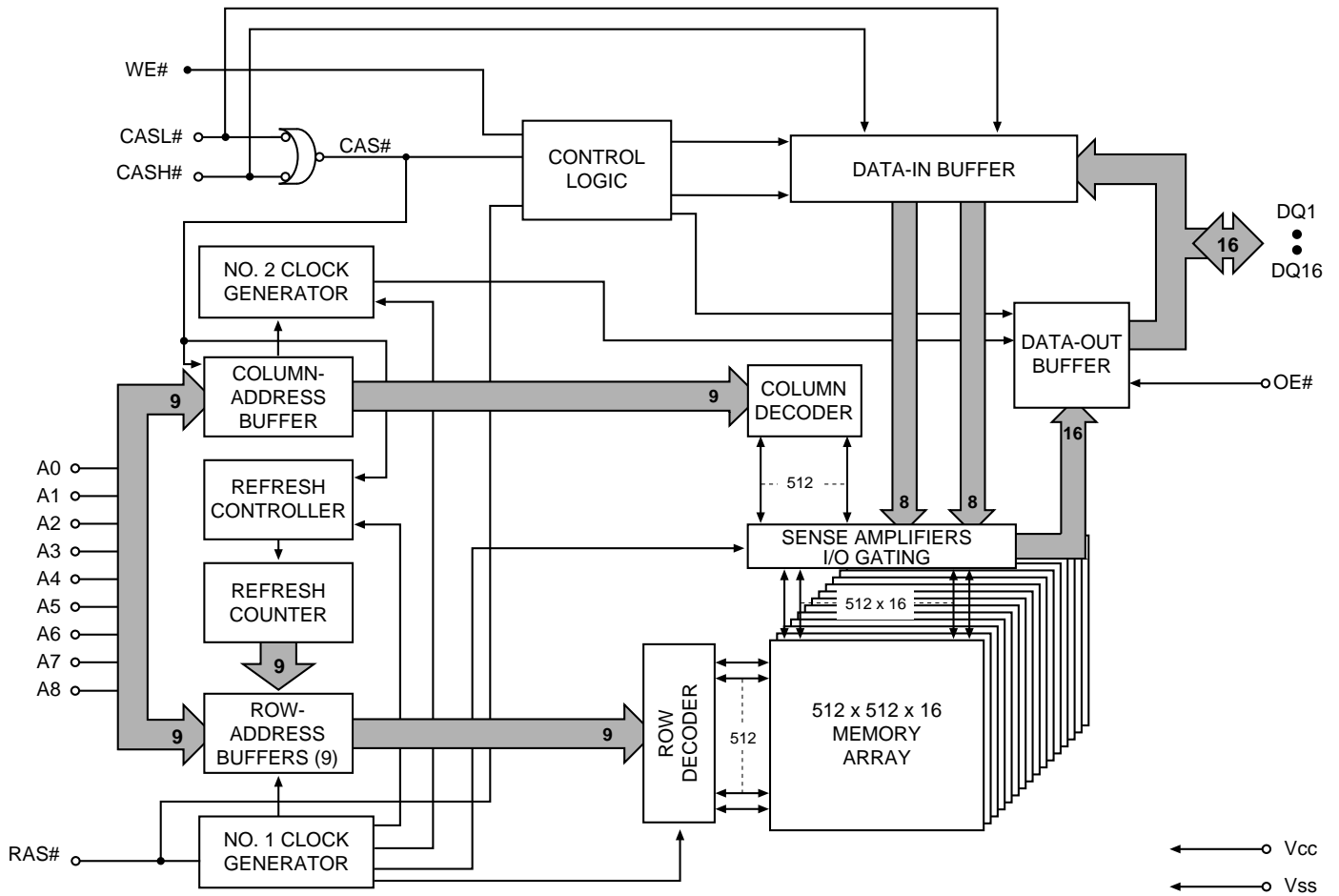

FUNCTIONAL DESCRIPTION

Each bit is uniquely addressed through the 18 address bits during READ or WRITE cycles. These are entered 9 bits (A0-A8) at a time. RAS# is used to latch the first 9 bits and CAS# the latter 9 bits.

The CAS# control also determines whether the cycle will be a refresh cycle (RAS#-ONLY) or an active cycle (READ, WRITE or READ WRITE) once RAS# goes LOW. The MT4C16270 has two CAS# controls, CASL# and CASH#.

The CASL# and CASH# inputs internally generate a CAS# signal functioning in a similar manner to the single CAS# input on the other 256K x 16 DRAMs. The key difference is that each CAS# controls its corresponding DQ tristate logic (in conjunction with OE# and WE# and RAS#). CASL# controls DQ1 through DQ8 and CASH# controls DQ9 through DQ16.

The MT4C16270 CAS# function is determined by the first CAS# (CASL# or CASH#) transitioning LOW and the last transitioning back HIGH. The two CAS# controls give the MT4C16270 both byte READ and byte WRITE cycle capabilities. (See Figure 2.)

A logic HIGH on WE# dictates READ mode while a logic LOW on WE# dictates WRITE mode. During a WRITE cycle, data-in (D) is latched by the falling edge of WE or CAS# (CASL# or CASH#), whichever occurs last. An EARLY WRITE occurs when WE is taken LOW prior to either CAS# falling. A LATE WRITE or READ-MODIFY-WRITE occurs when WE falls after CAS# (CASL# or CASH#) was taken LOW. During EARLY WRITE cycles, the data-outputs (Q) will remain High-Z regardless of the state of OE#. During LATE WRITE or READ-MODIFY-WRITE cycles, OE# must

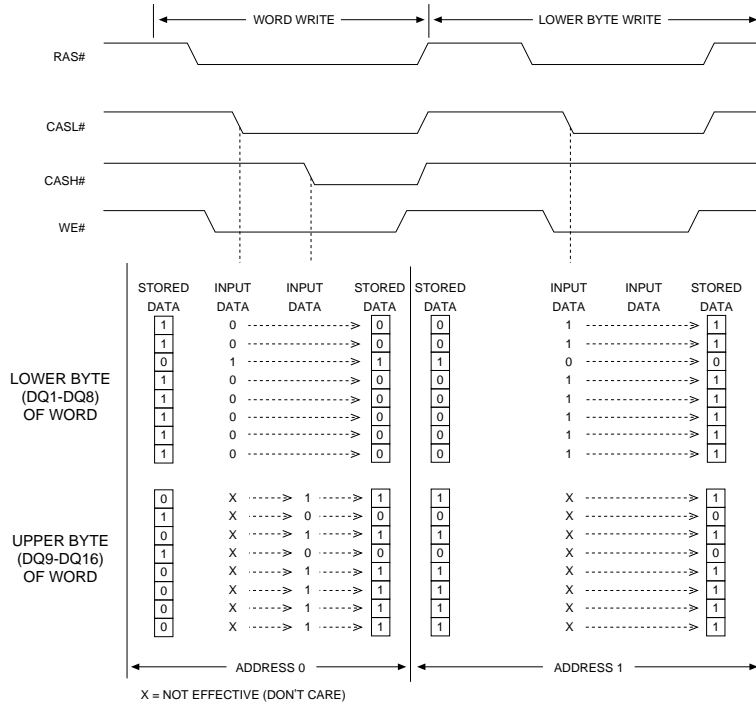

Figure 1
WORD AND BYTE WRITE EXAMPLE

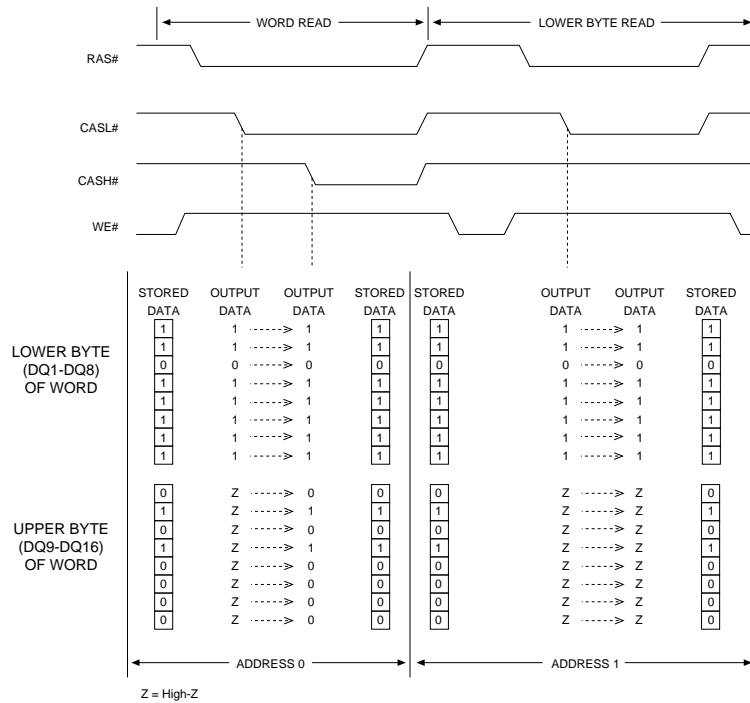

Figure 2
WORD AND BYTE READ EXAMPLE

FUNCTIONAL DESCRIPTION (continued)

be taken HIGH to disable the data-outputs prior to applying input data. If a LATE WRITE or READ-MODIFY-WRITE is attempted while keeping OE# LOW, no write will occur, and the data-outputs will drive read data from the accessed location.

Additionally, both bytes must always be of the same mode of operation if both bytes are active. A CAS# precharge must be satisfied prior to changing modes of operation between the upper and lower bytes. For example, an EARLY WRITE on one byte and a LATE WRITE on the other byte is not allowed during the same cycle. However, an EARLY WRITE on one byte and, after a CAS# precharge has been satisfied, a LATE WRITE on the other byte is permissible.

The 16 data inputs and 16 data outputs are routed through 16 pins using common I/O, and pin direction is controlled by OE#, WE# and RAS#.

EDO PAGE MODE operations allow faster data operations (READ, WRITE or READ-MODIFY-WRITE) within a

row-address-defined (A0-A8) page boundary. The EDO PAGE MODE cycle is always initiated with a row address strobed-in by RAS# followed by a column address strobed-in by CAS#. CAS# may be toggled by holding RAS# LOW and strobing-in different column-addresses, thus executing faster memory cycles. Returning RAS# HIGH terminates the EDO PAGE MODE operation.

BYTE ACCESS CYCLE

The BYTE WRITE cycle is determined by the use of CASL# and CASH#. Enabling CASL# will select a lower BYTE WRITE cycle (DQ1-DQ8) while enabling CASH# will select an upper BYTE WRITE cycle (DQ9-DQ16). Enabling both CASL# and CASH# selects a WORD WRITE cycle.

The MT4C16270 can be viewed as two 256K x 8 DRAMs which have common input controls. Figure 1 illustrates the MT4C16270 BYTE WRITE and WORD WRITE cycles. The BYTE READ is accomplished in the same manner.

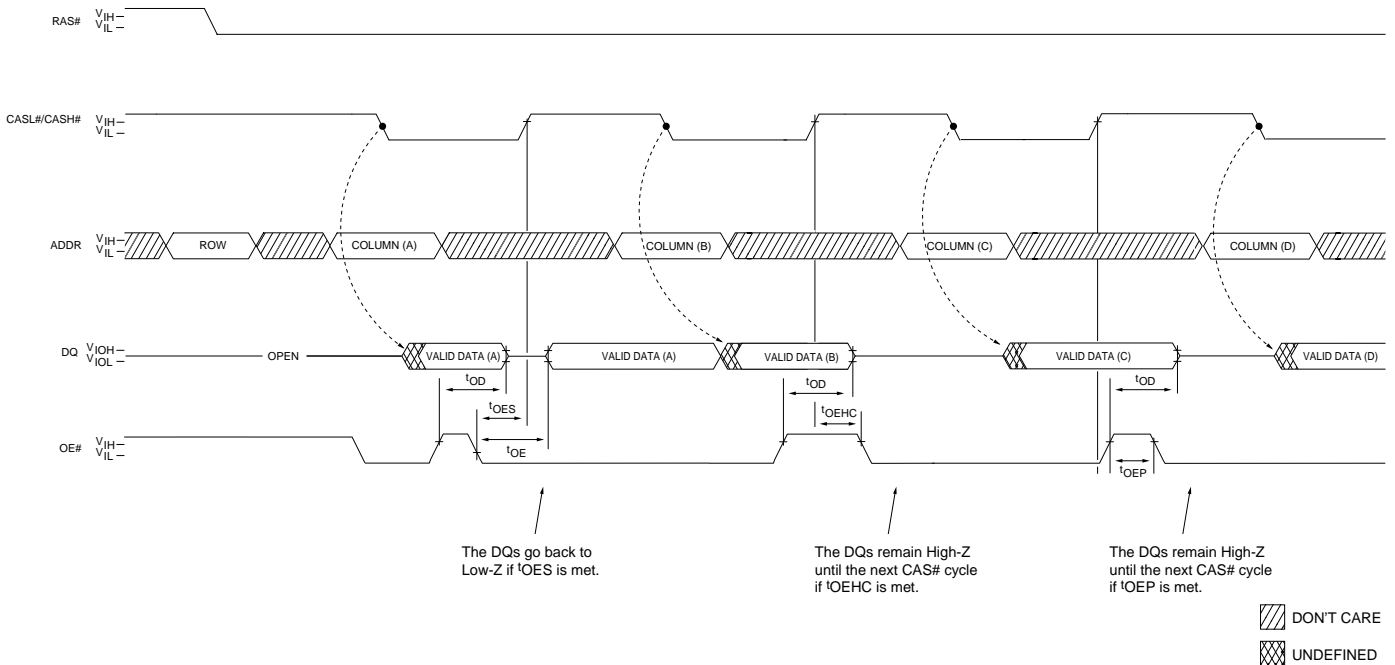

Figure 3
OUTPUT ENABLE AND DISABLE

EDO PAGE MODE

DRAM READ cycles have traditionally turned the output buffers off (High-Z) with the rising edge of CAS#. If CAS# goes HIGH, and OE# is LOW (active), the output buffers will be disabled. The MT4C16270 offers an accelerated PAGE MODE cycle by eliminating output disable from CAS# HIGH. This option is called EDO and it allows CAS# precharge time (^tCP) to occur without the output data going invalid (see READ and EDO-PAGE-MODE READ waveforms).

EDO operates as any DRAM READ or FAST-PAGE-MODE READ, except data will be held valid after CAS# goes HIGH, as long as RAS# and OE# are held LOW and WE# is held HIGH. OE# can be brought LOW or HIGH while CAS# and RAS# are LOW, and the DQs will transition between valid data and High-Z. Using OE#, there are two methods to disable the outputs and keep them disabled during the CAS# HIGH time. The first method is to have OE# HIGH when CAS# transitions HIGH and keep OE# HIGH for ^tOEHC. This will tristate the DQs and they will remain tristate, regardless of OE#, until CAS# falls again. The second method is to have OE# LOW when CAS#

transitions HIGH. Then OE# can pulse HIGH for a minimum of ^tOEP anytime during the CAS# HIGH period and the DQs will tristate and remain tristate, regardless of OE#, until CAS# falls again (please reference Figure 3 for further detail on the toggling OE# condition). During other cycles, the outputs are disabled at ^tOFF time after RAS# and CAS# are HIGH, or ^tWHZ after WE# transitions LOW. The ^tOFF time is referenced from the rising edge of RAS# or CAS#, whichever occurs last. WE# can also perform the function of turning off the output drivers under certain conditions, as shown in Figure 4.

Returning RAS# and CAS# HIGH terminates a memory cycle and decreases chip current to a reduced standby level. The chip is also preconditioned for the next cycle during the RAS# HIGH time. Memory cell data is retained in its correct state by maintaining power and executing any RAS# cycle (READ, WRITE) or RAS# refresh cycle (RAS#-ONLY, CBR, or HIDDEN) so that all 512 combinations of RAS# addresses (A0-A8) are executed at least every 8ms, regardless of sequence. The CBR REFRESH cycle will also invoke the refresh counter and controller for row address control.

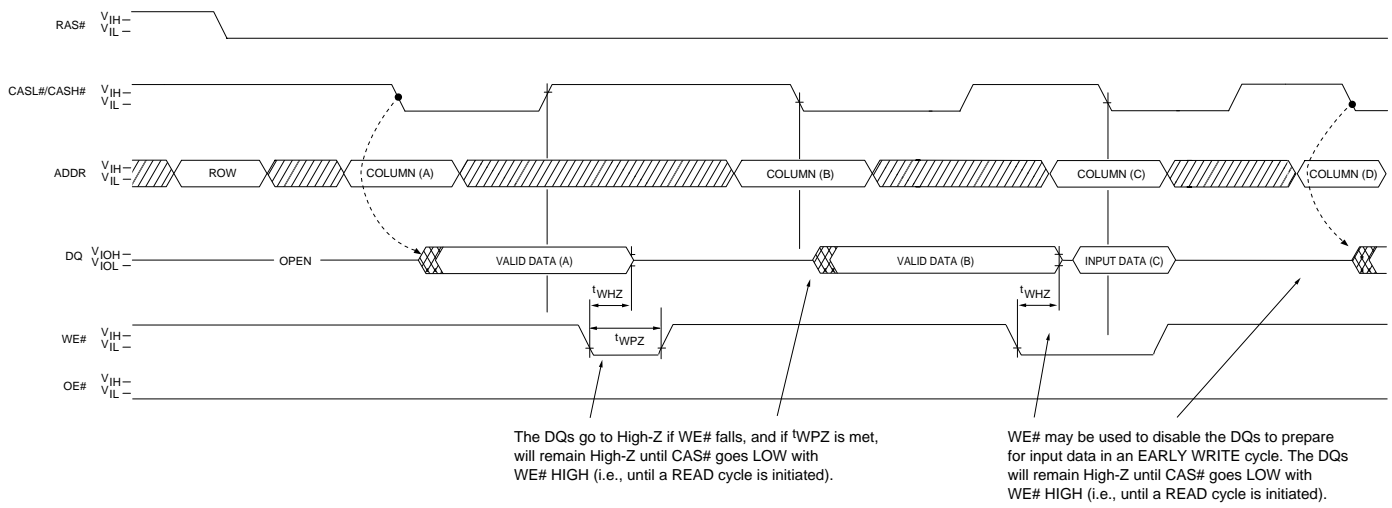

▨ DON'T CARE
▩ UNDEFINED

Figure 4
OUTPUT ENABLE AND DISABLE WITH WE#

TRUTH TABLE

| FUNCTION | RAS# | CASL# | CASH# | WE# | OE# | ADDRESSES | | DOs | NOTES | |
|---------------------------------|-----------|-------|-------|-----|-----|----------------|----------------|--|-------------------|------|
| | | | | | | t _R | t _C | | | |
| Standby | H | H→X | H→X | X | X | X | X | High-Z | | |
| READ: WORD | L | L | L | H | L | ROW | COL | Data-Out | | |
| READ: LOWER BYTE | L | L | H | H | L | ROW | COL | Lower Byte, Data-Out Upper Byte, High-Z | | |
| READ: UPPER BYTE | L | H | L | H | L | ROW | COL | Lower Byte, High-Z Upper Byte, Data Out | | |
| WRITE: WORD (EARLY WRITE) | L | L | L | L | X | ROW | COL | Data-In | | |
| WRITE: LOWER BYTE (EARLY) | L | L | H | L | X | ROW | COL | Lower Byte, Data-In Upper Byte, High-Z | | |
| WRITE: UPPER BYTE (EARLY) | L | H | L | L | X | ROW | COL | Lower Byte, High-Z Upper Byte, Data-In | | |
| READ WRITE | L | L | L | H→L | L→H | ROW | COL | Data-Out, Data-In | 1, 2 | |
| EDO-PAGE- MODE READ | 1st Cycle | L | H→L | H→L | H | L | ROW | COL | Data-Out | 2 |
| | 2nd Cycle | L | H→L | H→L | H | L | n/a | COL | Data-Out | 2 |
| | Any Cycle | L | L→H | L→H | H | L | n/a | n/a | Data-Out | 2 |
| EDO-PAGE- MODE WRITE | 1st Cycle | L | H→L | H→L | L | X | ROW | COL | Data-In | 1 |
| | 2nd Cycle | L | H→L | H→L | L | X | n/a | COL | Data-In | 1 |
| EDO- PAGE-MODE READ-WRITE | 1st Cycle | L | H→L | H→L | H→L | L→H | ROW | COL | Data-Out, Data-In | 1, 2 |
| | 2nd Cycle | L | H→L | H→L | H→L | L→H | n/a | COL | Data-Out, Data-In | 1, 2 |
| HIDDEN REFRESH | READ | L→H→L | L | L | H | L | ROW | COL | Data-Out | 2 |
| | WRITE | L→H→L | L | L | L | X | ROW | COL | Data-In | 1, 3 |
| RAS#-ONLY REFRESH | L | H | H | X | X | ROW | n/a | High-Z | | |
| CBR REFRESH | H→L | L | L | X | X | X | X | High-Z | 4 | |

- NOTE:**
1. These WRITE cycles may also be BYTE WRITE cycles (either CASL# or CASH# active).
 2. These READ cycles may also be BYTE READ cycles (either CASL# or CASH# active).
 3. EARLY WRITE only.
 4. At least one of the two CAS# signals must be active (CASL# or CASH#).

ABSOLUTE MAXIMUM RATINGS*

Voltage on any pin Relative to V_{SS} -1V to +7V
 Operating Temperature, T_A (ambient) 0°C to +70°C
 Storage Temperature (plastic) -55°C to +150°C
 Power Dissipation 1.2W
 Short Circuit Output Current 50mA

*Stresses greater than those listed under “Absolute Maximum Ratings” may cause permanent damage to the device. This is a stress rating only and functional operation of the device at these or any other conditions above those indicated in the operational sections of this specification is not implied. Exposure to absolute maximum rating conditions for extended periods may affect reliability.

ELECTRICAL CHARACTERISTICS AND RECOMMENDED DC OPERATING CONDITIONS

(Notes: 1, 6, 7) (V_{CC} = +5V ±10%)**

| PARAMETER/CONDITION | SYMBOL | MIN | MAX | UNITS | NOTES |
|---|--------------------|------|--------------------|-------|-------|
| Supply Voltage | V _{CC} ** | 4.5 | 5.5 | V | |
| Input High (Logic 1) Voltage, all inputs | V _{IH} | 2.4 | V _{CC} +1 | V | |
| Input Low (Logic 0) Voltage, all inputs | V _{IL} | -1.0 | 0.8 | V | |
| INPUT LEAKAGE CURRENT Any input 0V ≤ V _{IN} ≤ V _{CC} +1.0V (All other pins not under test = 0V) | I _I | -2 | 2 | μA | 3 |
| OUTPUT LEAKAGE CURRENT (Q is disabled; 0V ≤ V _{OUT} ≤ V _{CC}) | I _{OZ} | -10 | 10 | μA | |
| OUTPUT LEVELS Output High Voltage (I _{OUT} = -2.5mA) | V _{OH} | 2.4 | | V | |
| Output Low Voltage (I _{OUT} = 2.1mA) | V _{OL} | | 0.4 | V | |

| PARAMETER/CONDITIONS | SYMBOL | MAX | | | UNITS | NOTES |
|---|------------------|-----|-----|-----|-------|-------|
| | | -4 | -5 | -6 | | |
| STANDBY CURRENT: (TTL) (RAS# = CAS# = V _{IH}) | I _{CC1} | 2 | 2 | 2 | mA | |
| STANDBY CURRENT: (CMOS) (RAS# = CAS# = V _{CC} -0.2V) | I _{CC2} | 1 | 1 | 1 | mA | 25 |
| OPERATING CURRENT: Random READ/WRITE Average power supply current (RAS#, CAS#, address cycling: t _{RC} = t _{RC} [MIN]) | I _{CC3} | 205 | 195 | 185 | mA | 4, 40 |
| OPERATING CURRENT: EDO PAGE MODE Average power supply current (RAS# = V _{IL} , CAS#, address cycling: t _{PC} = t _{PC} [MIN]; t _{CP} , t _{ASC} = 10ns) | I _{CC4} | 125 | 120 | 115 | mA | 4, 40 |
| REFRESH CURRENT: RAS#-ONLY Average power supply current (RAS# cycling, CAS#=V _{IH} : t _{RC} = t _{RC} [MIN]) | I _{CC5} | 205 | 195 | 185 | mA | 4 |
| REFRESH CURRENT: CBR Average power supply current (RAS#, CAS#, address cycling: t _{RC} = t _{RC} [MIN]) | I _{CC6} | 180 | 170 | 160 | mA | 4, 5 |

**40 and 50ns specifications are limited to a V_{CC} range of ±5%.

CAPACITANCE

| PARAMETER | SYMBOL | MAX | UNITS | NOTES |
|---|-----------------|-----|-------|-------|
| Input Capacitance: A0-A8 | C _{I1} | 5 | pF | 2 |
| Input Capacitance: RAS#, CASL#, CASH#, WE#, OE# | C _{I2} | 7 | pF | 2 |
| Input/Output Capacitance: DQ | C _{I0} | 7 | pF | 2 |

ELECTRICAL CHARACTERISTICS AND RECOMMENDED AC OPERATING CONDITIONS

 (Notes: 6, 7, 8, 9, 10, 11, 12, 13) (V_{CC} = +5V ±10%)*

| AC CHARACTERISTICS | SYM | -4 | | -5 | | -6 | | UNITS | NOTES |
|---|-------------------|-----|--------|-----|--------|-----|--------|-------|----------------|
| | | MIN | MAX | MIN | MAX | MIN | MAX | | |
| Access time from column-address | ^t AA | | 20 | | 25 | | 30 | ns | |
| Column-address setup to CAS# precharge during WRITE | ^t ACH | 15 | | 15 | | 15 | | ns | |
| Column-address hold time (referenced to RAS#) | ^t AR | 30 | | 40 | | 40 | | ns | |
| Column-address setup time | ^t ASC | 0 | | 0 | | 0 | | ns | 29 |
| Row-address setup time | ^t ASR | 0 | | 0 | | 0 | | ns | |
| Column-address to WE# delay time | ^t AWD | 37 | | 48 | | 55 | | ns | 21 |
| Access time from CAS# | ^t CAC | | 12 | | 15 | | 15 | ns | 15, 31 |
| Column-address hold time | ^t CAH | 7 | | 8 | | 10 | | ns | 29 |
| CAS# pulse width | ^t CAS | 6 | 10,000 | 8 | 10,000 | 10 | 10,000 | ns | 37 |
| CAS# hold time (CBR REFRESH) | ^t CHR | 10 | | 10 | | 10 | | ns | 5, 30 |
| Last CAS# going LOW to first CAS# returning HIGH | ^t CLCH | 10 | | 10 | | 10 | | ns | 32 |
| CAS# to output in Low-Z | ^t CLZ | 3 | | 3 | | 3 | | ns | 31, 41 |
| Data output hold after CAS# LOW | ^t COH | 3 | | 3 | | 3 | | ns | |
| CAS# precharge time | ^t CP | 6 | | 8 | | 10 | | ns | 16, 34 |
| Access time from CAS# precharge | ^t CPA | 25 | | | 28 | | 35 | ns | 31 |
| CAS# to RAS# precharge time | ^t CRP | 5 | | 5 | | 5 | | ns | 30 |
| CAS# hold time | ^t CSH | 37 | | 40 | | 45 | | ns | 30 |
| CAS# setup time (CBR REFRESH) | ^t CSR | 10 | | 10 | | 10 | | ns | 5, 29 |
| CAS# to WE# delay time | ^t CWD | 30 | | 35 | | 40 | | ns | 21, 29 |
| Write command to CAS# lead time | ^t CWL | 7 | | 8 | | 10 | | ns | 26, 30 |
| Data-in hold time | ^t DH | 7 | | 8 | | 10 | | ns | 22, 31 |
| Data-in setup time | ^t DS | 0 | | 0 | | 0 | | ns | 22, 31 |
| Output disable time | ^t OD | 3 | 15 | 3 | 15 | 3 | 15 | ns | 28, 39, 41 |
| Output Enable time | ^t OE | | 10 | | 15 | | 15 | ns | 23, 31 |
| OE# hold time from WE# during READ-MODIFY-WRITE cycle | ^t OEH | 6 | | 10 | | 15 | | ns | 27 |
| OE# HIGH hold time from CAS# HIGH | ^t OEHC | 10 | | 10 | | 10 | | ns | |
| OE# HIGH pulse width | ^t OEP | 10 | | 10 | | 10 | | ns | |
| OE# LOW to CAS# HIGH setup time | ^t OES | 5 | | 5 | | 5 | | ns | |
| Output buffer turn-off delay from CAS# or RAS# | ^t OFF | 3 | 15 | 3 | 15 | 3 | 15 | ns | 20, 28, 31, 41 |

 *40ns and 50ns specifications are limited to a V_{CC} range of ±5%.

ELECTRICAL CHARACTERISTICS AND RECOMMENDED AC OPERATING CONDITIONS

 (Notes: 6, 7, 8, 9, 10, 11, 12, 13) (V_{cc} = +5V ±10%)*

| AC CHARACTERISTICS | | -4 | | -5 | | -6 | | | |
|---|-------------------|-----|---------|-----|---------|-----|---------|-------|------------|
| PARAMETER | SYM | MIN | MAX | MIN | MAX | MIN | MAX | UNITS | NOTES |
| OE# setup prior to RAS# during HIDDEN REFRESH cycle | ^t ORD | 0 | | 0 | | 0 | | ns | |
| EDO-PAGE-MODE READ or WRITE cycle time | ^t PC | 15 | | 20 | | 25 | | ns | 33 |
| EDO-PAGE-MODE READ-WRITE cycle time | ^t PRWC | 60 | | 65 | | 72 | | ns | 33 |
| Access time from RAS# | ^t RAC | | 40 | | 50 | | 60 | ns | 14 |
| RAS# to column-address delay time | ^t RAD | 7 | | 13 | | 15 | | ns | 18 |
| Row-address hold time | ^t RAH | 7 | | 10 | | 10 | | ns | |
| Column-address to RAS# lead time | ^t RAL | 15 | | 17 | | 22 | | ns | |
| RAS# pulse width | ^t RAS | 40 | 10,000 | 50 | 10,000 | 60 | 10,000 | ns | |
| RAS# pulse width (EDO PAGE MODE) | ^t RASP | 40 | 100,000 | 50 | 100,000 | 60 | 100,000 | ns | |
| Random READ or WRITE cycle time | ^t RC | 70 | | 100 | | 110 | | ns | |
| RAS# to CAS# delay time | ^t RCD | 17 | | 18 | | 20 | | ns | 17, 29 |
| Read command hold time (referenced to CAS#) | ^t RCH | 0 | | 0 | | 0 | | ns | 19, 26, 30 |
| Read command setup time | ^t RCS | 0 | | 0 | | 0 | | ns | 26, 29 |
| Refresh period (512 cycles) | ^t REF | | 8 | | 8 | | 8 | ms | |
| RAS# precharge time | ^t RP | 25 | | 30 | | 35 | | ns | |
| RAS# to CAS# precharge time | ^t RPC | 10 | | 10 | | 10 | | ns | |
| Read command hold time (referenced to RAS#) | ^t RRH | 0 | | 0 | | 0 | | ns | 19 |
| RAS# hold time | ^t RSH | 7 | | 8 | | 10 | | ns | 38 |
| READ WRITE cycle time | ^t RWC | 105 | | 126 | | 140 | | ns | |
| RAS# to WE# delay time | ^t RWD | 60 | | 69 | | 85 | | ns | 21 |
| Write command to RAS# lead time | ^t RWL | 7 | | 8 | | 10 | | ns | 26 |
| Transition time (rise or fall) | ^t T | 1 | 50 | 2 | 50 | 2 | 50 | ns | 9, 10 |
| Write command hold time | ^t WCH | 7 | | 8 | | 10 | | ns | 26, 38 |
| Write command hold time (referenced to RAS#) | ^t WCR | 30 | | 40 | | 40 | | ns | 26 |
| Write command setup time | ^t WCS | 0 | | 0 | | 0 | | ns | 21, 26, 29 |
| Output disable delay from WE# | ^t WHZ | 3 | 13 | 3 | 13 | 3 | 15 | ns | |
| Write command pulse width | ^t WP | 7 | | 8 | | 10 | | ns | 26 |
| WE# pulse widths to disable outputs | ^t WPZ | 10 | | 10 | | 10 | | ns | |
| WE# hold time (CBR REFRESH) | ^t WRH | 10 | | 10 | | 10 | | ns | |
| WE# setup time (CBR REFRESH) | ^t WRP | 10 | | 10 | | 10 | | ns | |

 *40ns and 50ns specifications are limited to a V_{cc} range of ±5%.

NOTES

1. All voltages referenced to V_{SS} .
2. This parameter is sampled. $V_{CC} = 4.75V$; $f = 1\text{ MHz}$.
3. NC pins are assumed to be left floating and are not tested for leakage.
4. I_{CC} is dependent on output loading and cycle rates. Specified values are obtained with minimum cycle time and the output open.
5. Enables on-chip refresh and address counters.
6. The minimum specifications are used only to indicate cycle time at which proper operation over the full temperature range ($0^{\circ}C \leq T_A \leq 70^{\circ}C$) is assured.
7. An initial pause of $100\mu s$ is required after power-up followed by eight RAS# refresh cycles (RAS#-ONLY or CBR) before proper device operation is assured. The eight RAS# cycle wake-ups should be repeated any time the t_{REF} refresh requirement is exceeded.
8. AC characteristics assume $t_T = 2ns$.
9. V_{IH} (MIN) and V_{IL} (MAX) are reference levels for measuring timing of input signals. Transition times are measured between V_{IH} and V_{IL} (or between V_{IL} and V_{IH}).
10. In addition to meeting the transition rate specification, all input signals must transit between V_{IH} and V_{IL} (or between V_{IL} and V_{IH}) in a monotonic manner.
11. If CAS# and RAS# = V_{IH} , data output is High-Z.
12. If CAS# = V_{IL} , data output may contain data from the last valid READ cycle.
13. Measured with a load equivalent to one TTL gate and $50pF$, $V_{OL} = 0.8V$ and $V_{OH} = 2.0V$.
14. Assumes that $t_{RCD} < t_{RCD} (MAX)$. If t_{RCD} is greater than the maximum recommended value shown in this table, t_{RAC} will increase by the amount that t_{RCD} exceeds the value shown.
15. Assumes that $t_{RCD} \geq t_{RCD} (MAX)$.
16. If CAS# is LOW at the falling edge of RAS#, Q will be maintained from the previous cycle. To initiate a new cycle and clear the Q buffer, CAS# and RAS# must be pulsed HIGH for t_{CP} .
17. The $t_{RCD} (MAX)$ limit is no longer specified. $t_{RCD} (MAX)$ was specified as a reference point only. If t_{RCD} was greater than the specified $t_{RCD} (MAX)$ limit, then access time was controlled exclusively by t_{CAC} [$t_{RAC} (MIN)$ no longer applied]. With or without the $t_{RCD} (MAX)$ limit, $t_{AA} (MIN)$, $t_{RAC} (MIN)$ and $t_{CAC} (MIN)$ must always be met.
18. The $t_{RAD} (MAX)$ limit is no longer specified. $t_{RAD} (MAX)$ was specified as a reference point only. If t_{RAD} was greater than the specified $t_{RAD} (MAX)$ limit, then access time was controlled exclusively by t_{AA} [$t_{RAC} (MIN)$ and $t_{CAC} (MIN)$ no longer applied]. With or without the $t_{RAD} (MAX)$ limit, $t_{AA} (MIN)$, $t_{RAC} (MIN)$ and $t_{CAC} (MIN)$ must always be met.
19. Either t_{RCH} or t_{RRH} must be satisfied for a READ cycle.
20. $t_{OFF} (MAX)$ defines the time at which the output achieves the open circuit condition; it is not a reference to V_{OH} or V_{OL} .
21. t_{WCS} , t_{RWD} , t_{AWD} and t_{CWD} are restrictive operating parameters in LATE WRITE and READ-MODIFY-WRITE cycles only. If $t_{WCS} \geq t_{WCS} (MIN)$, the cycle is an EARLY WRITE cycle and the data output will remain an open circuit throughout the entire cycle. If $t_{RWD} \geq t_{RWD} (MIN)$, $t_{AWD} \geq t_{AWD} (MIN)$ and $t_{CWD} \geq t_{CWD} (MIN)$, the cycle is a READ-WRITE and the data output will contain data read from the selected cell. If neither of the above conditions is met, the state of Q (at access time and until CAS# and RAS# or OE# go back to V_{IH}) is indeterminate. OE# held HIGH and WE# taken LOW after CAS# goes LOW result in a LATE WRITE (OE#-controlled) cycle.
22. These parameters are referenced to CAS# leading edge in EARLY WRITE cycles and WE# leading edge in LATE WRITE or READ-MODIFY-WRITE cycles.
23. During a READ cycle, if OE# is LOW then taken HIGH before CAS# goes HIGH, Q goes open. If OE# is tied permanently LOW, a LATE WRITE or READ-MODIFY-WRITE operation is not possible.
24. A HIDDEN REFRESH may also be performed after a WRITE cycle. In this case, WE# = LOW and OE# = HIGH.
25. All other inputs at $V_{CC} - 0.2V$.
26. Write command is defined as WE# going LOW.
27. LATE WRITE and READ-MODIFY-WRITE cycles must have both t_{OD} and t_{OEH} met (OE# HIGH during WRITE cycle) in order to ensure that the output buffers will be open during the WRITE cycle. The DQs will provide the previously written data if CAS# remains LOW and OE# is taken back LOW after t_{OEH} is met.

NOTES (continued)

- 28. The DQs open during READ cycles once t_{OD} or t_{OFF} occur.
- 29. The first CAS#x edge to transition LOW.
- 30. The last CAS#x edge to transition HIGH.
- 31. Output parameter (DQx) is referenced to corresponding CAS# input, DQ1-DQ8 by CASL# and DQ9-DQ16 by CASH#.
- 32. Last falling CAS#x edge to first rising CAS#x edge.
- 33. Last rising CAS#x edge to next cycle's last rising CAS#x edge.
- 34. Last rising CAS#x edge to first falling CAS#x edge.
- 35. First DQs controlled by the first CAS#x to go LOW.
- 36. Last DQs controlled by the last CAS#x to go HIGH.
- 37. Each CAS#x must meet minimum pulse width.
- 38. Last CAS#x to go LOW.
- 39. All DQs controlled, regardless CASL# and CASH#.
- 40. Column address changed once each cycle.
- 41. The 3ns minimum is a parameter guaranteed by design.

READ CYCLE

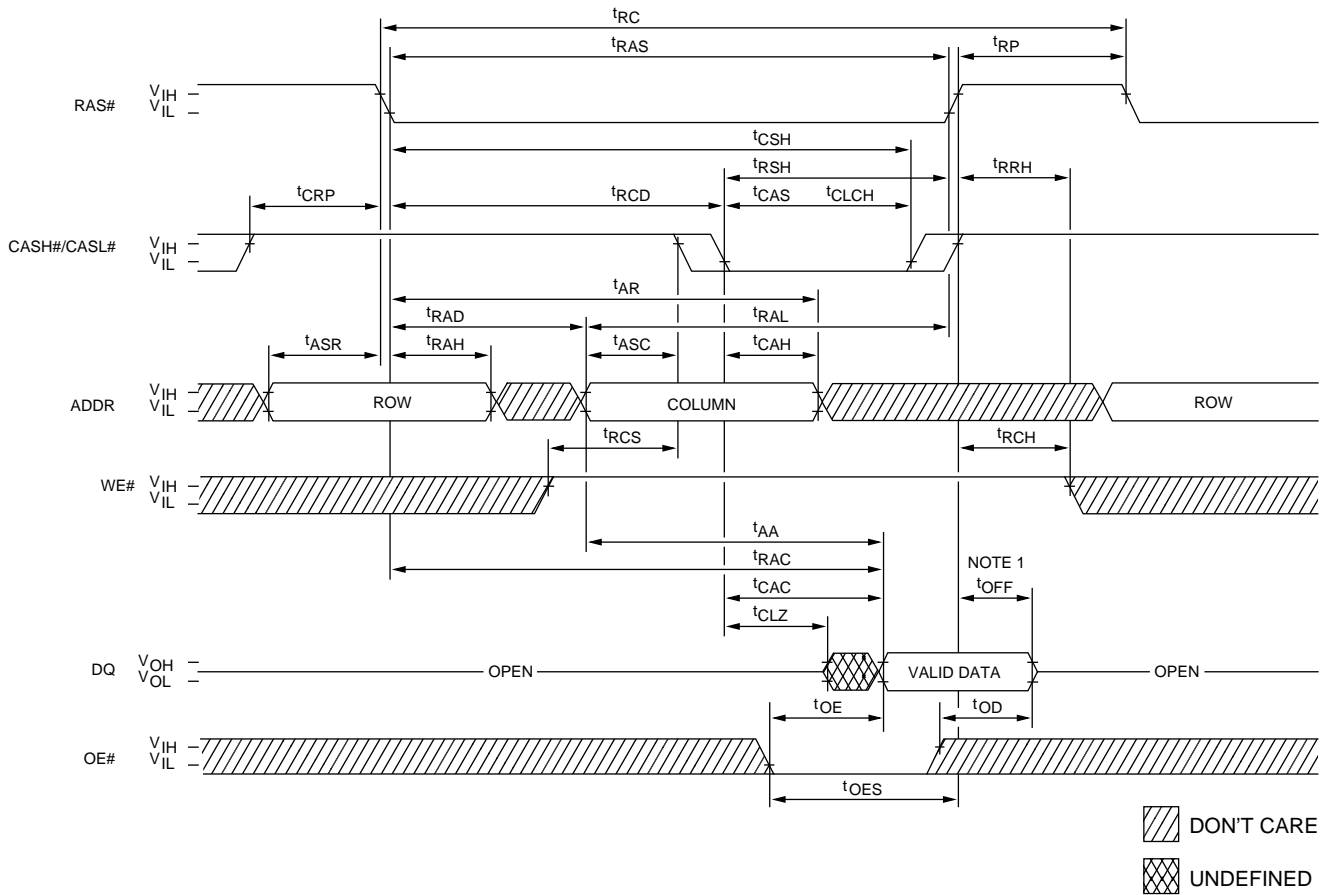

TIMING PARAMETERS

| | -4 | | -5 | | -6 | | |
|------------|-----|--------|-----|--------|-----|--------|-------|
| SYM | MIN | MAX | MIN | MAX | MIN | MAX | UNITS |
| t_{AA} | | 20 | | 25 | | 30 | ns |
| t_{AR} | 30 | | 40 | | 40 | | ns |
| t_{ASC} | 0 | | 0 | | 0 | | ns |
| t_{ASR} | 0 | | 0 | | 0 | | ns |
| t_{CAC} | | 12 | | 15 | | 15 | ns |
| t_{CAH} | 7 | | 8 | | 10 | | ns |
| t_{CAS} | 6 | 10,000 | 8 | 10,000 | 10 | 10,000 | ns |
| t_{CLCH} | 10 | | 10 | | 10 | | ns |
| t_{CLZ} | 3 | | 3 | | 3 | | ns |
| t_{CRP} | 5 | | 5 | | 5 | | ns |
| t_{CSH} | 37 | | 40 | | 40 | | ns |
| t_{OD} | 3 | 15 | 3 | 15 | 3 | 15 | ns |
| t_{OE} | | 10 | | 15 | | 15 | ns |
| t_{OES} | | 5 | | 5 | | 5 | ns |

| | -4 | | -5 | | -6 | | |
|-----------|-----|--------|-----|--------|-----|--------|-------|
| SYM | MIN | MAX | MIN | MAX | MIN | MAX | UNITS |
| t_{OFF} | 3 | 15 | 3 | 15 | 3 | 15 | ns |
| t_{RAC} | | 40 | | 50 | | 60 | ns |
| t_{RAD} | 7 | | 13 | | 15 | | ns |
| t_{RAH} | 7 | | 10 | | 10 | | ns |
| t_{RAL} | 15 | | 17 | | 22 | | ns |
| t_{RAS} | 40 | 10,000 | 50 | 10,000 | 60 | 10,000 | ns |
| t_{RC} | 75 | | 100 | | 110 | | ns |
| t_{RCD} | 17 | | 18 | | 20 | | ns |
| t_{RCH} | 0 | | 0 | | 0 | | ns |
| t_{RCS} | 0 | | 0 | | 0 | | ns |
| t_{RP} | 25 | | 30 | | 35 | | ns |
| t_{RRH} | 0 | | 0 | | 0 | | ns |
| t_{RSH} | 8 | | 10 | | 15 | | ns |

NOTE: 1. t_{OFF} is referenced from the rising edge of RAS# or CAS#, whichever occurs last.

EARLY WRITE CYCLE

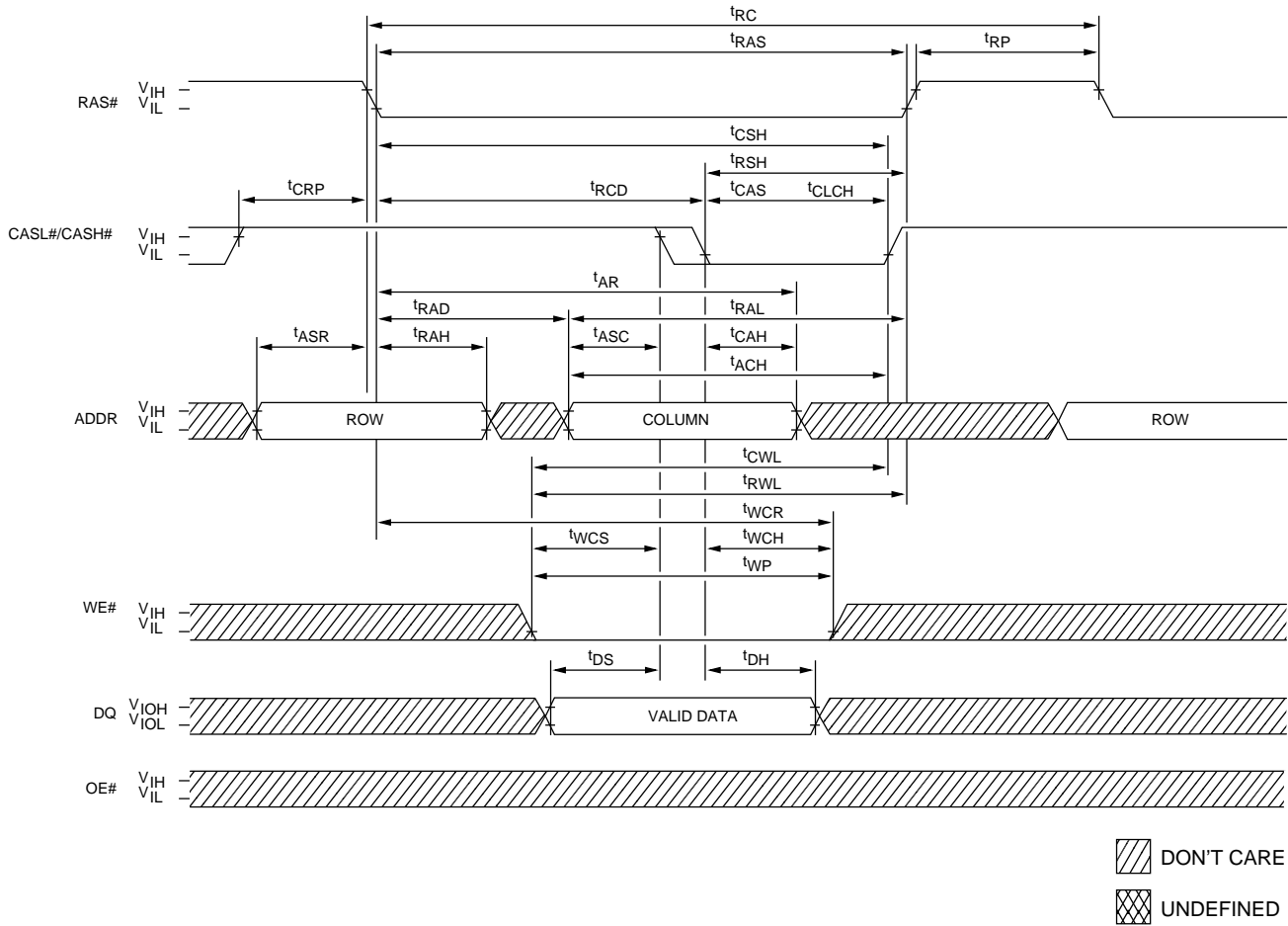

TIMING PARAMETERS

| SYM | -4 | | -5 | | -6 | | UNITS |
|---------------------|-----|--------|-----|--------|-----|--------|-------|
| | MIN | MAX | MIN | MAX | MIN | MAX | |
| t ¹ ACH | 15 | | 15 | | 15 | | ns |
| t ¹ AR | 30 | | 40 | | 40 | | ns |
| t ¹ ASC | 0 | | 0 | | 0 | | ns |
| t ¹ ASR | 0 | | 0 | | 0 | | ns |
| t ¹ CAH | 7 | | 8 | | 10 | | ns |
| t ¹ CAS | 6 | 10,000 | 8 | 10,000 | 10 | 10,000 | ns |
| t ¹ CLCH | 10 | | 10 | | 10 | | ns |
| t ¹ CRP | 5 | | 5 | | 5 | | ns |
| t ¹ CSH | 37 | | 40 | | 40 | | ns |
| t ¹ CWL | 7 | | 8 | | 10 | | ns |
| t ¹ DH | 7 | | 8 | | 10 | | ns |
| t ¹ DS | 0 | | 0 | | 0 | | ns |
| t ¹ RAD | 7 | | 13 | | 15 | | ns |

| SYM | -4 | | -5 | | -6 | | UNITS |
|--------------------|-----|--------|-----|--------|-----|--------|-------|
| | MIN | MAX | MIN | MAX | MIN | MAX | |
| t ¹ RAH | 7 | | 10 | | 10 | | ns |
| t ¹ RAL | 15 | | 17 | | 22 | | ns |
| t ¹ RAS | 40 | 10,000 | 50 | 10,000 | 60 | 10,000 | ns |
| t ¹ RC | 75 | | 100 | | 110 | | ns |
| t ¹ RCD | 17 | | 18 | | 20 | | ns |
| t ¹ RP | 25 | | 30 | | 35 | | ns |
| t ¹ RSH | 7 | | 8 | | 10 | | ns |
| t ¹ RWL | 7 | | 8 | | 10 | | ns |
| t ¹ WCH | 7 | | 8 | | 10 | | ns |
| t ¹ WCR | 30 | | 40 | | 40 | | ns |
| t ¹ WCS | 0 | | 0 | | 0 | | ns |
| t ¹ WP | 7 | | 8 | | 10 | | ns |

READ WRITE CYCLE
(LATE WRITE and READ-MODIFY-WRITE cycles)

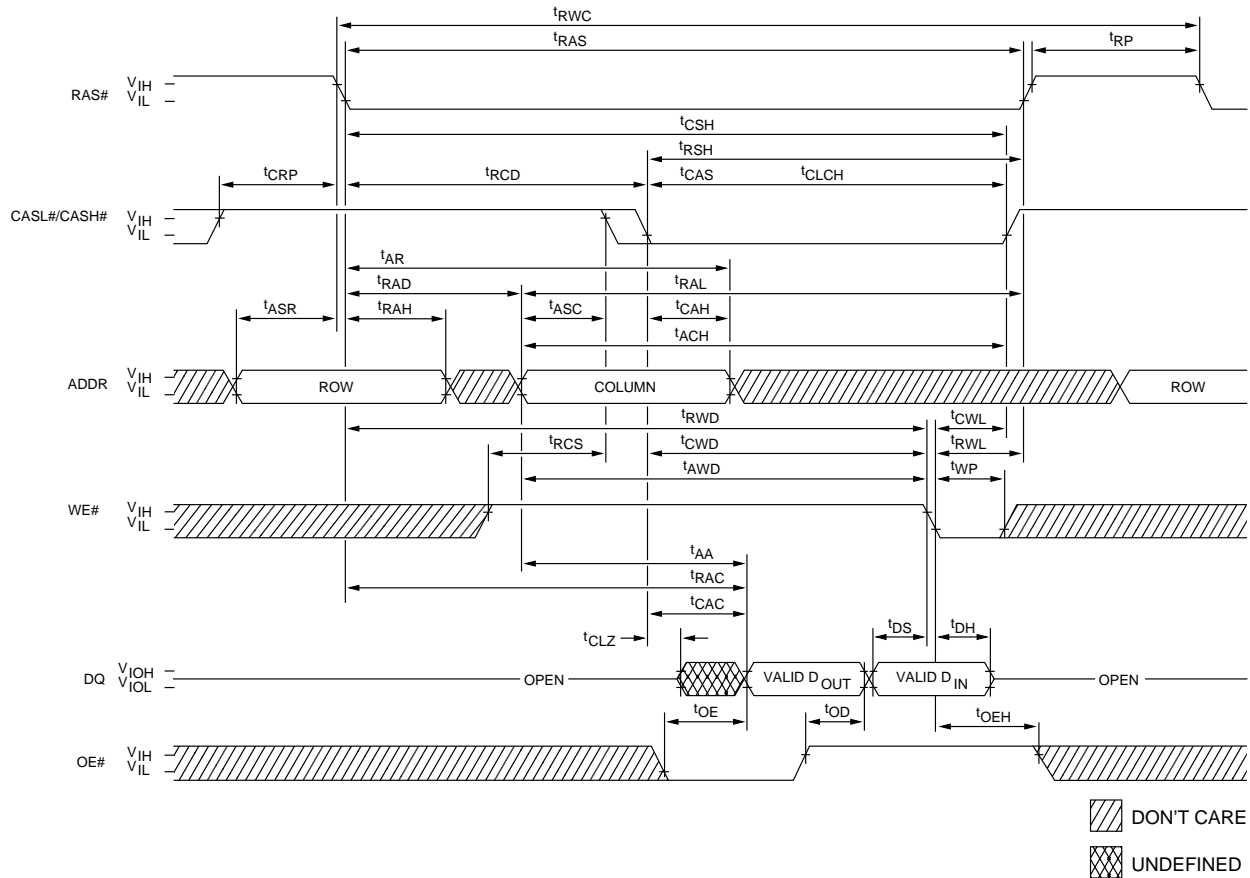

TIMING PARAMETERS

| SYM | -4 | | -5 | | -6 | | UNITS |
|-------|-----|--------|-----|--------|-----|--------|-------|
| | MIN | MAX | MIN | MAX | MIN | MAX | |
| tAA | | 30 | 15 | 25 | 15 | 30 | ns |
| tACH | 15 | | 15 | | 15 | | ns |
| tAR | 30 | | 40 | | 40 | | ns |
| tASC | 0 | | 0 | | 0 | | ns |
| tASR | 0 | | 0 | | 0 | | ns |
| tAWD | 37 | | 48 | | 55 | | ns |
| tCAC | | 12 | | 15 | | 15 | ns |
| tCAH | 7 | | 8 | | 10 | | ns |
| tCAS | 6 | 10,000 | 8 | 10,000 | 10 | 10,000 | ns |
| tCLCH | 10 | | 10 | | 10 | | ns |
| tCLZ | 3 | | 3 | | 3 | | ns |
| tCRP | 5 | | 5 | | 5 | | ns |
| tCSH | 37 | | 40 | | 40 | | ns |
| tCWD | 30 | | 35 | | 40 | | ns |
| tCWL | 7 | | 8 | | 10 | | ns |
| tDH | 7 | | 8 | | 10 | | ns |
| tDS | 0 | | 0 | | 0 | | ns |

| SYM | -4 | | -5 | | -6 | | UNITS |
|------|-----|--------|-----|--------|-----|--------|-------|
| | MIN | MAX | MIN | MAX | MIN | MAX | |
| tOD | 3 | 15 | 3 | 15 | 3 | 15 | ns |
| tOE | | 10 | | 15 | | 15 | ns |
| tOEH | 6 | | 10 | | 15 | | ns |
| tRAC | | 40 | | 50 | | 60 | ns |
| tRAD | 7 | | 13 | | 15 | | ns |
| tRAH | 7 | | 10 | | 10 | | ns |
| tRAL | 15 | | 17 | | 22 | | ns |
| tRAS | 40 | 10,000 | 50 | 10,000 | 60 | 10,000 | ns |
| tRCD | 17 | | 18 | | 20 | | ns |
| tRCS | 0 | | 0 | | 0 | | ns |
| tRP | 25 | | 30 | | 35 | | ns |
| tRSH | 7 | | 8 | | 10 | | ns |
| tRWC | 105 | | 126 | | 140 | | ns |
| tRWD | 60 | | 69 | | 85 | | ns |
| tRWL | 7 | | 8 | | 10 | | ns |
| tWP | 7 | | 8 | | 10 | | ns |

EDO-PAGE-MODE READ-EARLY-WRITE CYCLE
(Pseudo READ-MODIFY-WRITE)

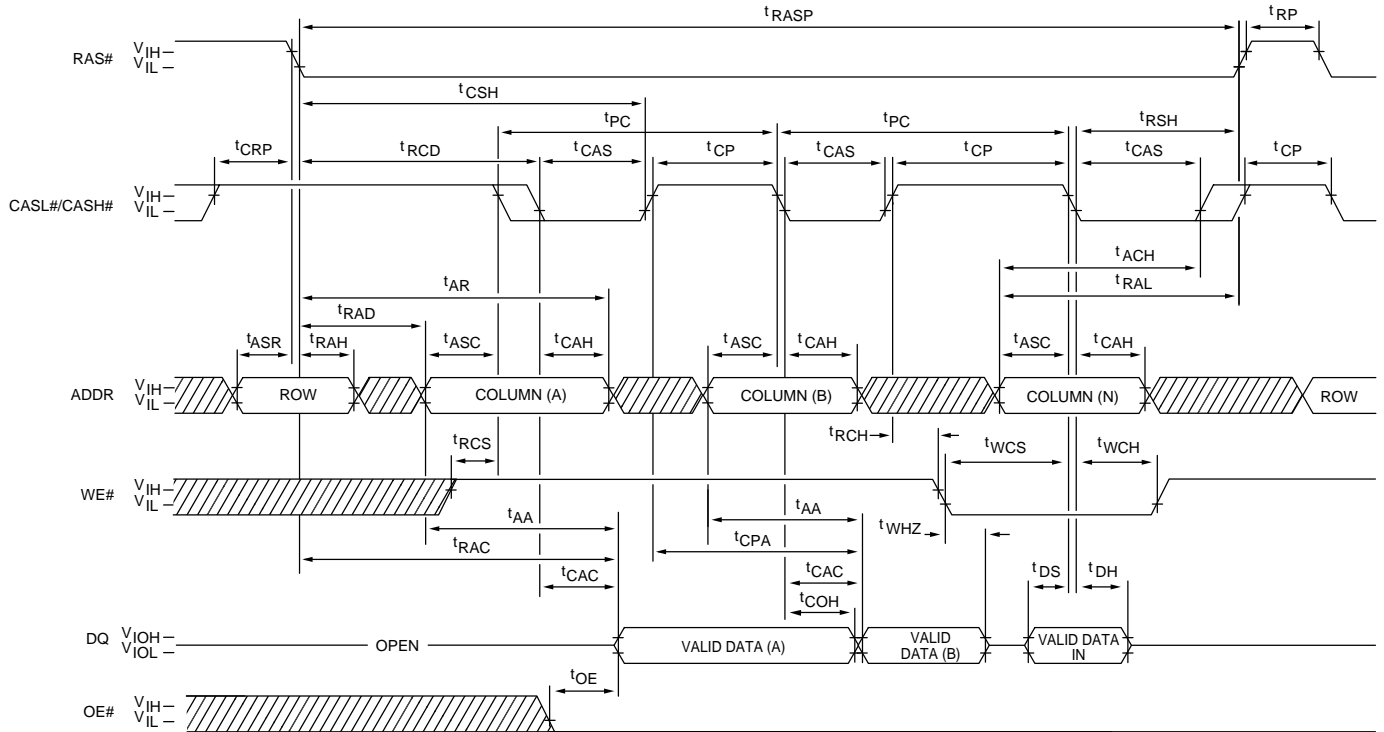

▨ DON'T CARE
▩ UNDEFINED

TIMING PARAMETERS

| SYM | -4 | | -5 | | -6 | | UNITS |
|------|-----|--------|-----|--------|-----|--------|-------|
| | MIN | MAX | MIN | MAX | MIN | MAX | |
| tAA | | 20 | 15 | 25 | 15 | 30 | ns |
| tACH | 15 | | 15 | | 15 | | ns |
| tAR | 37 | | 40 | | 40 | | ns |
| tASC | 0 | | 0 | | 0 | | ns |
| tASR | 0 | | 0 | | 0 | | ns |
| tCAC | | 12 | | 15 | | 15 | ns |
| tCAH | 7 | | 8 | | 10 | | ns |
| tCAS | 6 | 10,000 | 8 | 10,000 | 10 | 10,000 | ns |
| tCOH | 3 | | 3 | | 3 | | ns |
| tCP | 6 | | 8 | | 10 | | ns |
| tCPA | | 25 | | 28 | | 35 | ns |
| tCRP | 5 | | 5 | | 5 | | ns |
| tCSH | 37 | | 40 | | 40 | | ns |
| tDH | 7 | | 8 | | 10 | | ns |
| tDS | 0 | | 0 | | 0 | | ns |

| SYM | -4 | | -5 | | -6 | | UNITS |
|-------|-----|---------|-----|---------|-----|---------|-------|
| | MIN | MAX | MIN | MAX | MIN | MAX | |
| tOE | | 10 | | 15 | | 15 | ns |
| tPC | 15 | | 20 | | 25 | | ns |
| tRAC | | 40 | | 50 | | 60 | ns |
| tRAD | 7 | | 13 | | 15 | | ns |
| tRAH | 7 | | 10 | | 10 | | ns |
| tRAL | 15 | | 17 | | 22 | | ns |
| tRASP | 40 | 100,000 | 50 | 100,000 | 60 | 100,000 | ns |
| tRCD | 17 | | 18 | | 20 | | ns |
| tRCH | 0 | | 0 | | 0 | | ns |
| tRCS | 0 | | 0 | | 0 | | ns |
| tRP | 25 | | 30 | | 35 | | ns |
| tRSH | 7 | | 8 | | 10 | | ns |
| tWCH | 7 | | 8 | | 10 | | ns |
| tWCS | 0 | | 0 | | 0 | | ns |
| tWHZ | 3 | 13 | 3 | 13 | 3 | 15 | ns |

READ CYCLE
(with WE#-controlled disable)

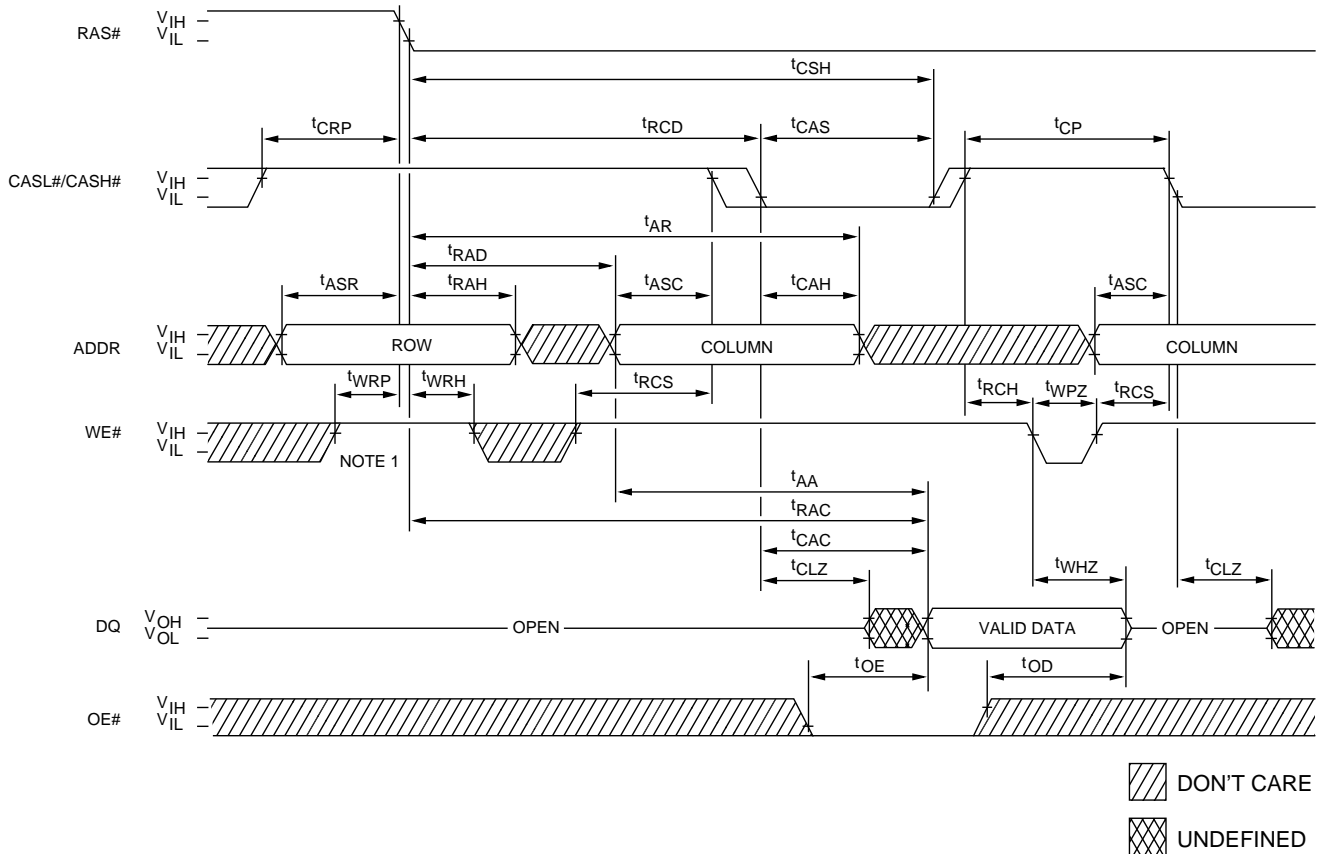

TIMING PARAMETERS

| SYM | -4 | | -5 | | -6 | | UNITS |
|------------------|-----|--------|-----|--------|-----|--------|-------|
| | MIN | MAX | MIN | MAX | MIN | MAX | |
| t _{AA} | | 20 | | 25 | | 30 | ns |
| t _{AR} | 30 | | 40 | | 40 | | ns |
| t _{ASC} | 0 | | 0 | | 0 | | ns |
| t _{ASR} | 0 | | 0 | | 0 | | ns |
| t _{CAC} | | 12 | | 15 | | 15 | ns |
| t _{CAH} | 7 | | 8 | | 10 | | ns |
| t _{CAS} | 6 | 10,000 | 8 | 10,000 | 10 | 10,000 | ns |
| t _{CLZ} | 3 | | 3 | | 3 | | ns |
| t _{CP} | 6 | | 8 | | 10 | | ns |
| t _{CRP} | 5 | | 5 | | 5 | | ns |
| t _{CSH} | 37 | | 40 | | 40 | | ns |
| t _{OD} | 3 | 15 | 3 | 15 | 3 | 15 | ns |

| SYM | -4 | | -5 | | -6 | | UNITS |
|------------------|-----|-----|-----|-----|-----|-----|-------|
| | MIN | MAX | MIN | MAX | MIN | MAX | |
| t _{OE} | | 10 | | 15 | | 15 | ns |
| t _{RAC} | | 40 | | 50 | | 60 | ns |
| t _{RAD} | 7 | | 13 | | 15 | | ns |
| t _{RAH} | 7 | | 10 | | 10 | | ns |
| t _{RCH} | 0 | | 0 | | 0 | | ns |
| t _{RCD} | 17 | | 18 | | 20 | | ns |
| t _{RCS} | 0 | | 0 | | 0 | | ns |
| t _{WHZ} | 3 | 13 | 3 | 13 | 3 | 15 | ns |
| t _{WPZ} | 10 | | 10 | | 10 | | ns |
| t _{WRH} | 10 | | 10 | | 10 | | ns |
| t _{WRP} | 10 | | 10 | | 10 | | ns |

NOTE: 1. Although WE# is a "don't care" at RAS# time during an access cycle (READ or WRITE), the system designer should implement WE# HIGH for t_{WRP} and t_{WRH}. This design implementation will facilitate compatibility with future EDO DRAMs.

RAS#-ONLY REFRESH CYCLE
(OE#, WE# = DON'T CARE)

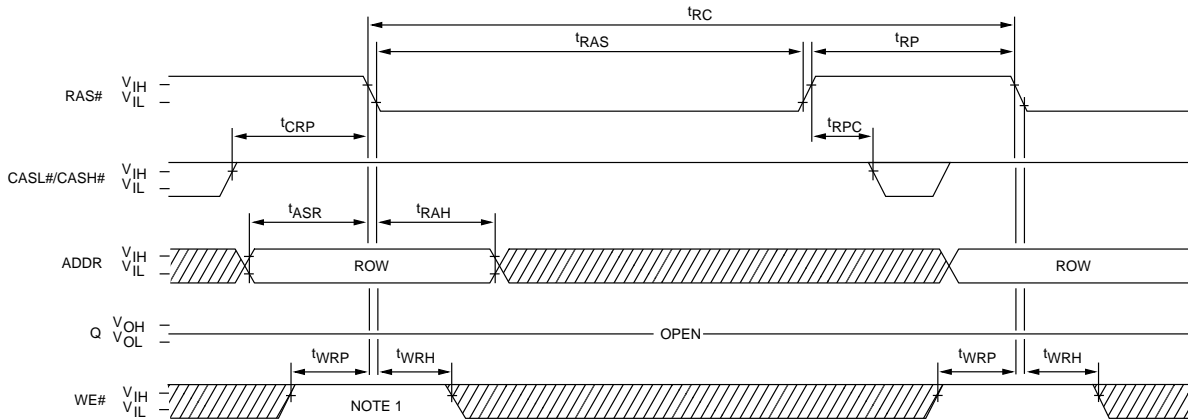

CBR REFRESH CYCLE
(Addresses; OE# = DON'T CARE)

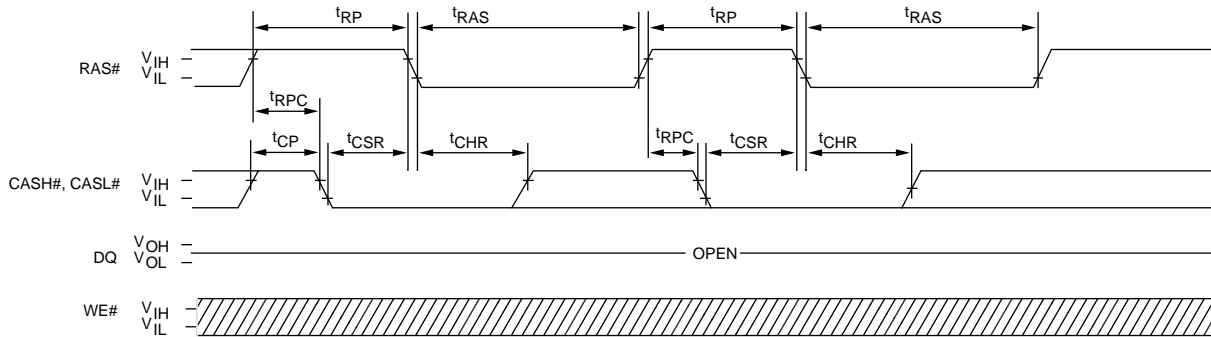

DON'T CARE
 UNDEFINED

TIMING PARAMETERS

| SYM | -4 | | -5 | | -6 | | UNITS |
|------------------|-----|-----|-----|-----|-----|-----|-------|
| | MIN | MAX | MIN | MAX | MIN | MAX | |
| t _{ASR} | 0 | | 0 | | 0 | | ns |
| t _{CHR} | 10 | | 10 | | 10 | | ns |
| t _{CP} | 6 | | 8 | | 10 | | ns |
| t _{CRP} | 5 | | 5 | | 5 | | ns |
| t _{CSR} | 10 | | 10 | | 10 | | ns |
| t _{RAH} | 7 | | 10 | | 10 | | ns |

| SYM | -4 | | -5 | | -6 | | UNITS |
|------------------|-----|--------|-----|--------|-----|--------|-------|
| | MIN | MAX | MIN | MAX | MIN | MAX | |
| t _{RAS} | 40 | 10,000 | 50 | 10,000 | 60 | 10,000 | ns |
| t _{RC} | 75 | | 100 | | 110 | | ns |
| t _{RP} | 25 | | 30 | | 35 | | ns |
| t _{RPC} | 10 | | 10 | | 10 | | ns |
| t _{WRH} | 10 | | 10 | | 10 | | ns |
| t _{WRP} | 10 | | 10 | | 10 | | ns |

NOTE: 1. Although WE# is a "don't care" at RAS# time during an access cycle (READ or WRITE), the system designer should implement WE# HIGH for t_{WRP} and t_{WRH}. This design implementation will facilitate compatibility with future EDO DRAMs.

HIDDEN REFRESH CYCLE²⁴
(WE# = HIGH; OE# = LOW)

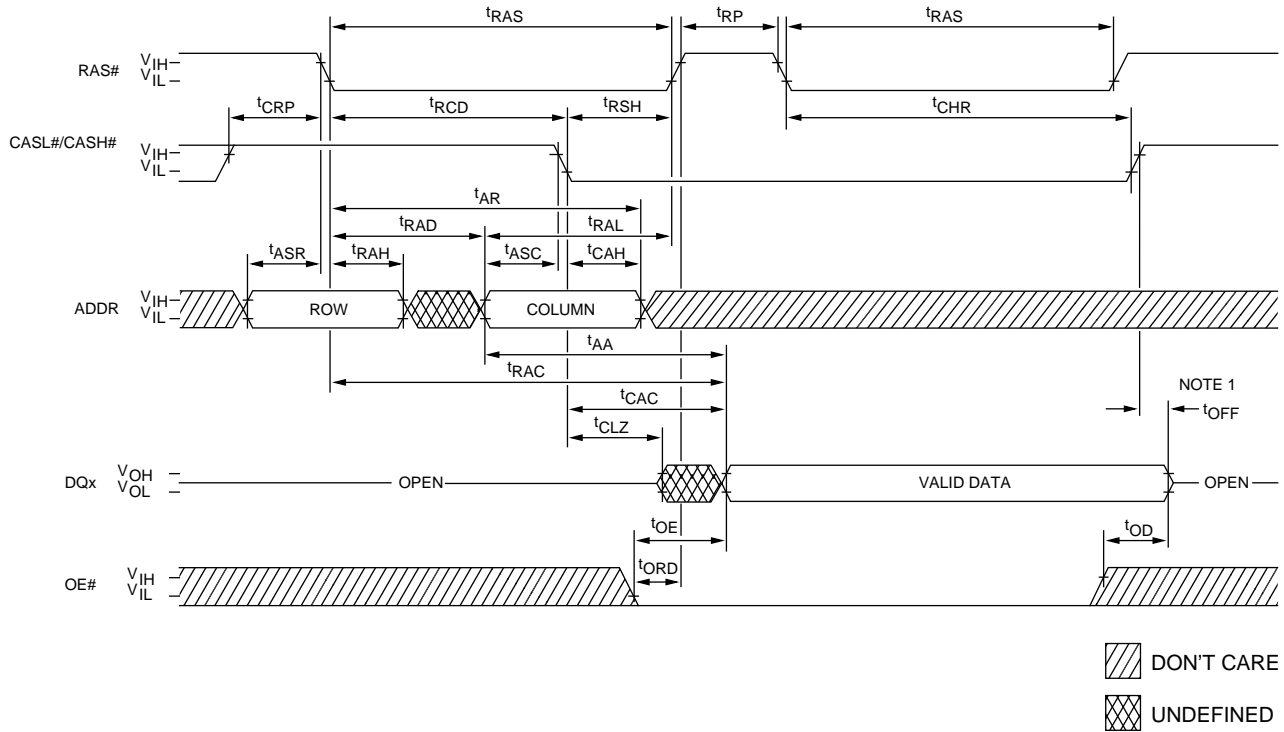

TIMING PARAMETERS

| SYM | -4 | | -5 | | -6 | | UNITS |
|------|-----|-----|-----|-----|-----|-----|-------|
| | MIN | MAX | MIN | MAX | MIN | MAX | |
| tAA | | 20 | | 25 | | 30 | ns |
| tAR | 30 | | 40 | | 40 | | ns |
| tASC | 0 | | 0 | | 0 | | ns |
| tASR | 0 | | 0 | | 0 | | ns |
| tCAC | | 12 | | 15 | | 15 | ns |
| tCAH | 7 | | 8 | | 10 | | ns |
| tCHR | 10 | | 10 | | 10 | | ns |
| tCLZ | 3 | | 3 | | 3 | | ns |
| tCRP | 5 | | 5 | | 5 | | ns |
| tOD | 3 | 15 | 3 | 15 | 3 | 15 | ns |
| tOE | | 10 | | 15 | | 15 | ns |

| SYM | -4 | | -5 | | -6 | | UNITS |
|------|-----|--------|-----|--------|-----|--------|-------|
| | MIN | MAX | MIN | MAX | MIN | MAX | |
| tOFF | 3 | 15 | 3 | 15 | 3 | 15 | ns |
| tORD | 0 | | 0 | | 0 | | ns |
| tRAC | | 40 | | 50 | | 60 | ns |
| tRAD | 7 | | 13 | | 15 | | ns |
| tRAH | 7 | | 10 | | 10 | | ns |
| tRAL | 15 | | 17 | | 22 | | ns |
| tRAS | 40 | 10,000 | 50 | 10,000 | 60 | 10,000 | ns |
| tRCD | 17 | | 18 | | 20 | | ns |
| tRP | 25 | | 30 | | 35 | | ns |
| tRSH | 7 | | 8 | | 10 | | ns |

NOTE: 1. tOFF is referenced from the rising edge of RAS# or CAS#, whichever occurs last.

