



ISO²-CMOS ST-BUS™ FAMILY MT9174

Digital Network Interface Circuit with Receive Sync Marker Bit

Features

- Receive sync output pulse
- Full duplex transmission over a single twisted pair
- Selectable 80 or 160 kbit/s line rate
- Adaptive echo cancellation
- Up to 4 km loop reach
- ISDN compatible (2B+D) data format
- Transparent modem capability
- Frame synchronization and clock extraction
- MITEL ST-BUS compatible
- Low power (typically 50 mW), single 5V supply

Applications

- TDD Digital PCS (DECT, CT2, PHS) base stations requiring cell synchronization
- Digital subscriber lines
- High speed data transmission over twisted wires
- Digital PABX line cards and telephone sets
- 80 or 160 kbit/s single chip modem

ISSUE 1

May 1995

Ordering Information

MT9174AE	24 Pin Plastic DIP
MT9174AN	24 Pin SSOP
MT9174AP	28 Pin PLCC

-40°C to +85°C

Description

The MT9174 is identical to the MT9172 in all respects except for the addition of one feature. The MT9174 includes a digital output pin indicating the temporal position of the "SYNC" bit of the biphasic transmission. This feature is especially useful for systems such as PCS wireless base stations applications requiring close synchronization between microcells.

The MT9174 is fabricated in Mitel's ISO²-CMOS process.

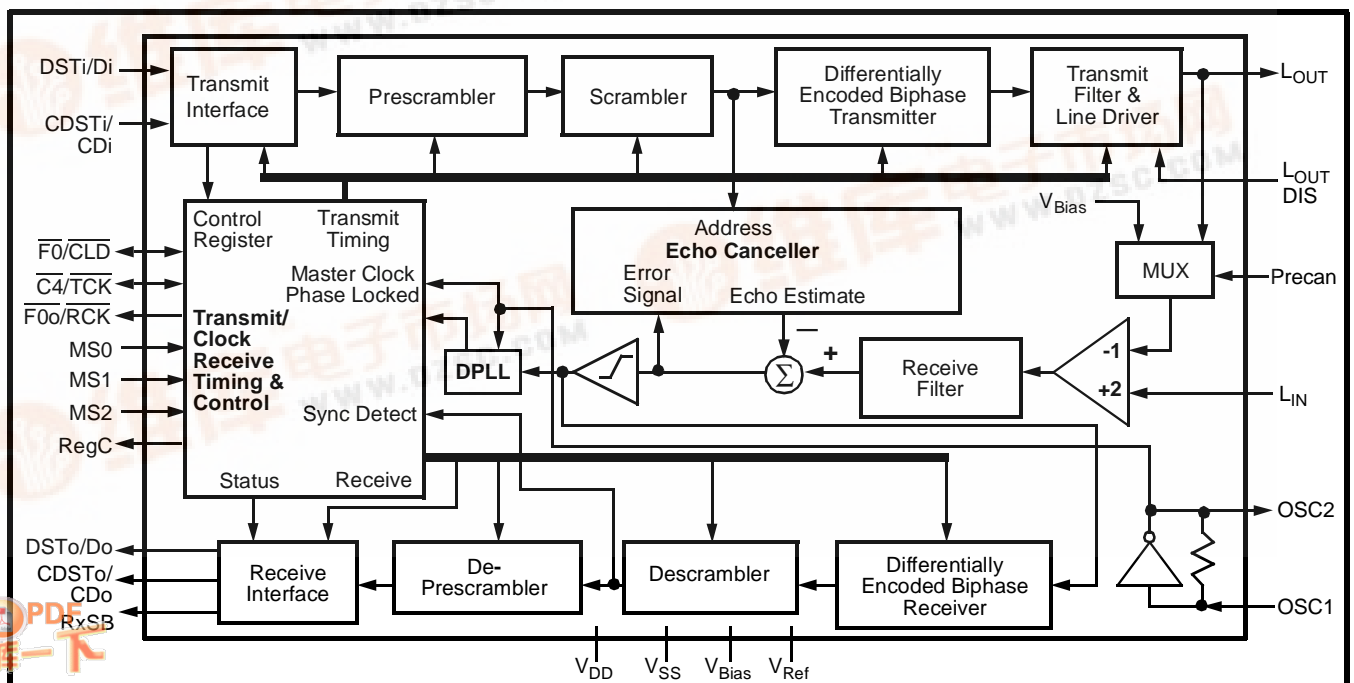

Figure 1 - Functional Block Diagram

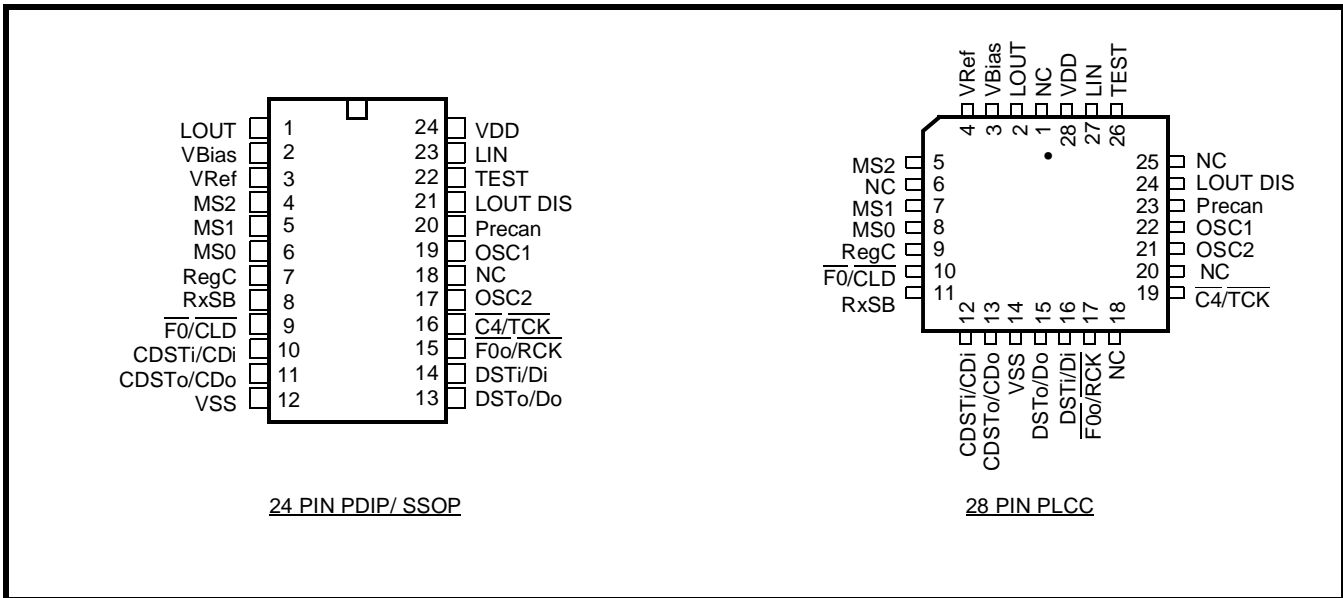

Figure 2 - Pin Connections

Pin Description

Pin #		Name	Description
24	28		
1	2	L _{OUT}	Line Out. Transmit Signal output (Analog). Referenced to V _{Bias} .
2	3	V _{Bias}	Internal Bias Voltage output. Connect via 0.33 μF decoupling capacitor to V _{DD} .
3	4	V _{Ref}	Internal Reference Voltage output. Connect via 0.33 μF decoupling capacitor to V _{DD} .
4,5,6	5,7,8	MS2-MS0	Mode Select inputs (Digital). The logic levels present on these pins select the various operating modes for a particular application. See Table 1 for the operating modes.
7	9	RegC	Regulator Control output (Digital). A 512 kHz clock used for switch mode power supplies. Unused in MAS/MOD mode and should be left open circuit.
8	11	RxSB	Receive Sync Bit output (Digital). This output is held high until receive synchronization occurs (i.e., until the sync bit in Status Register =1). Once low, indicating synchronized transmission, a high going pulse (6.24 μs wide pulse @ 160 kb/s and 12.5 μs wide @ 80 kb/s) indicates the temporal position of the receive "SYNC" bit in the biphas line transmission.
9	10	F ₀ /CLD	Frame Pulse/C-Channel Load (Digital). In DN mode a 244 ns wide negative pulse input for the MASTER indicating the start of the active channel times of the device. Output for the SLAVE indicating the start of the active channel times of the device. Output in MOD mode providing a pulse indicating the start of the C-channel.
10	12	CDSTi/CDi	Control/Data ST-BUS In/Control/Data In (Digital). A 2.048 Mbit/s serial control & signalling input in DN mode. In MOD mode this is a continuous bit stream at the bit rate selected.
11	13	CDSTo/CDo	Control/Data ST-BUS Out/Control/Data Out (Digital). A 2.048 Mbit/s serial control & signalling output in DN mode. In MOD mode this is a continuous bit stream at the bit rate selected.
12	14	V _{SS}	Negative Power Supply (0V).
13	15	DSTo/Do	Data ST-BUS Out/Data Out (Digital). A 2.048 Mbit/s serial PCM/data output in DN mode. In MOD mode this is a continuous bit stream at the bit rate selected.
14	16	DSTi/Di	Data ST-BUS In/Data In (Digital). A 2.048 Mbit/s serial PCM/data input in DN mode. In MOD mode this is a continuous bit stream at the bit rate selected.

Pin Description (continued)

Pin #		Name	Description
24	28		
15	17	$\overline{F0o/RCK}$	Frame Pulse Out/Receive Bit Rate Clock output (Digital). In DN mode a 244 ns wide negative pulse indicating the end of the active channel times of the device to allow daisy chaining. In MOD mode provides the receive bit rate clock to the system.
16	19	$\overline{C4/TCK}$	Data Clock/Transmit Baud Rate Clock (Digital). A 4.096 MHz TTL compatible clock input for the MASTER and output for the SLAVE in DN mode. For MOD mode this pin provides the transmit bit rate clock to the system.
17	21	OSC2	Oscillator Output. CMOS Output.
19	22	OSC1	Oscillator Input. CMOS Input. D.C. couple signals to this pin. Refer to D.C. Electrical Characteristics for OSC1 input requirements.
20	23	Precan	Precanceller Disable. When held to Logic '1', the internal path from L _{OUT} to the precanceller is forced to V _{Bias} thus bypassing the precanceller section. When logic '0', the L _{OUT} to the precanceller path is enabled and functions normally. An internal pulldown (50 kΩ) is provided on this pin.
18	1,6, 18, 20, 25	NC	No Connection. Leave open circuit
21	24	L _{OUT} DIS	L_{OUT} Disable. When held to logic "1", L _{OUT} is disabled (i.e., output = V _{Bias}). When logic "0", L _{OUT} functions normally. An internal pulldown (50 kΩ) is provided on this pin.
22	26	TEST	Test Pin. Connect to V _{SS} .
23	27	L _{IN}	Receive Signal input (Analog).
24	28	V _{DD}	Positive Power Supply (+5V) input.

NOTES: