

Infrared Emitter

MTE8080F

Applications -

- Bar Code Scanning
- Fiber Optics

Features -

- High Output Power
- Excellent Optical/Mechanical Axis Alignment
- Designed to Interface With External Optics

MAXIMUM RATINGS (Ta = 25°C)

CHARACTERISTIC	SYMBOL	RATING	UNIT
Forward Current	I_F	100	mA
Pulse Forward Current	I_{FP}	1.0*	A
Reverse Voltage	V_R	5	V
Power Dissipation	P_D	180	mW
Operating Temperature	T_{opr}	-20~80	°C
Storage Temperature	T_{stg}	-30~100	°C
Junction Temperature	T_j	100	°C

* $t_w = 10\mu s$, $T = 10ms$

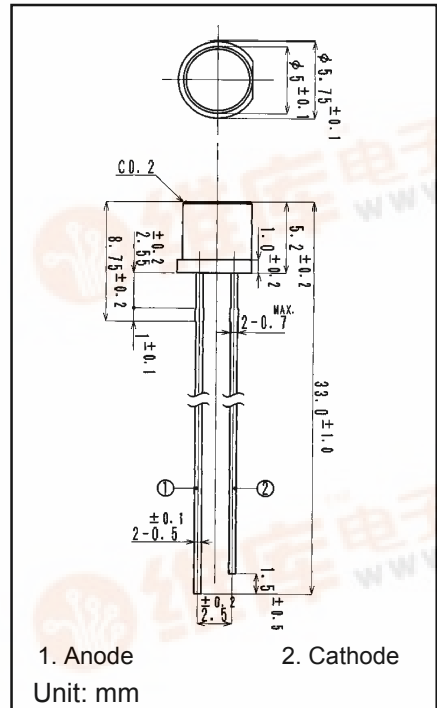

OPTO-ELECTRICAL CHARACTERISTICS (Ta = 25°C)

CHARACTERISTIC	SYMBOL	TEST CONDITION	MIN.	TYP.	MAX.	UNIT
Power Output	PO	IF = 50mA	—	11	—	mW
Forward Voltage	V_F	IF = 50mA	—	1.45	1.7	V
Reverse Current	I_R	VR = 5V	—	—	10	μA
Peak Wavelength	λ_p	IF = 20mA	—	880	—	nm
Spectral Line Half Width	$\Delta\lambda$	IF = 20mA	—	60	—	nm
Rise Time	T_r	—	—	1.5	—	μs
Fall Time	T_f	—	—	0.8	—	μs
Beam Angle	θ	—	—	± 65	—	°
Temperature Coefficient of PO	TC of PO	IF = 10mA	—	-0.5	—	% / °C
Temperature Coefficient of VF	TC of VF	IF = 10mA	—	-1.5	—	mV / °C



Infrared Emitter

MTE8080F Graphs -

