

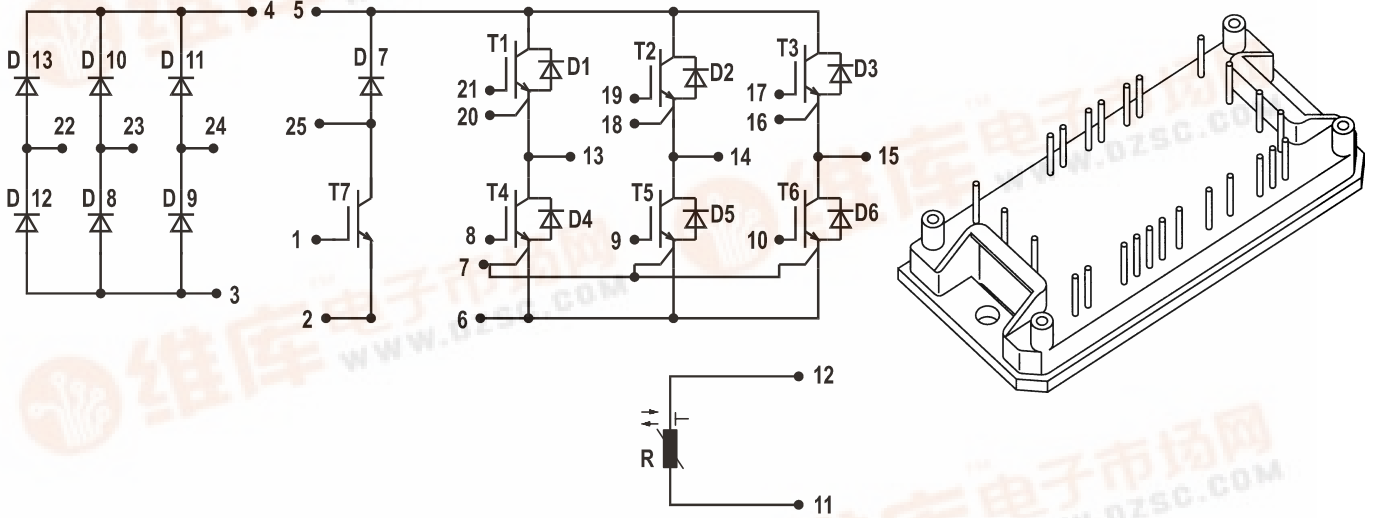

Converter - Brake - Inverter Module (CBI1)



Rectifier	Brake	Inverter
$V_{RRM} = 1200V$	$V_{CES} = 600V$	$V_{CES} = 600V$
$I_{FAVM} = 11A$	$I_{C25} = 11A$	$I_{C25} = 18A$
$I_{FSM} = 250A$	$V_{CE(sat)} = 2V$	$V_{CE(sat)} = 2.1V$

Input Rectifier Bridge D8 - D13		
Symbol	Conditions	Maximum Ratings
V_{RRM}		1200 V
I_F	$T_{VJ} = 25^{\circ}C$	36 A
I_{FAVM}	$T_{VJ} = 150^{\circ}C; T_K = 70^{\circ}C$	11 A
I_{FSM}	$T_{VJ} = 45^{\circ}C; t = 10\text{ ms sine } 50\text{ Hz}$	250 A
i^2t	$T_{VJ} = 125^{\circ}C$	310 A ² s
T_{VJ}		+150 $^{\circ}C$

Features

- NPT IGBT technology Square RBSOA, no latchup
- Free wheeling diodes with Hiperfast and soft recovery behaviour
- Isolation voltage 2500 V~
- Built in temperature sense
- High level of integration: one module for complete drive system
- Direct Copper Bonded Al₂O₃ ceramic base plate

Applications

- AC motor control
- AC servo and robot drives

Advantages

- No need of external isolation
- Easy to mount with two screws
- Package designed for wave soldering
- High temperature and power cycling capability

Symbol	Conditions	Characteristic Values ($T_{VJ} = 25^{\circ}C$, unless otherwise specified)		
		min.	typ.	max.
I_R	$V_{RRM} = 1200V; T_{VJ} = 25^{\circ}C$ $T_{VJ} = 125^{\circ}C$			10 μA 3 mA
V_F	$I_F = 36A$		1.15	1.4 V
R_{thJC}	per die		1.4	$^{\circ}C/W$

Output Inverter T1 - T6, D1 - D6

Symbol	Conditions	Maximum Ratings	
V_{CES}	$T_{VJ} = 25^{\circ}\text{C}$	600	V
V_{CGR}	$T_{VJ} = 25^{\circ}\text{C}; R_{GE} = 20\text{k}\Omega$	600	V
V_{GE}	$T_{VJ} = 25^{\circ}\text{C}$	± 20	V
I_C	$T_C = 25^{\circ}\text{C}$	18	A
	$T_C = 90^{\circ}\text{C}$	10	A
I_{CM}	$t_p = 1 \text{ ms} = 1\% \text{ duty cycle}; T_C = 25^{\circ}\text{C}$	36	A
		$T_C = 90^{\circ}\text{C}$	20
t_{sc}	IGBT $V_{CE} = 600 \text{ V}; T_{VJ} = 125^{\circ}\text{C}$ non-repetitive	10	μs
P_{tot}	$T_C = 25^{\circ}\text{C}$	61	W
T_{VJ}	Free-Wheeling Diode	+150	$^{\circ}\text{C}$
T_{VJ}	IGBT	+150	$^{\circ}\text{C}$

Symbol	Conditions	Characteristic Values ($T_{VJ} = 25^{\circ}\text{C}$, unless otherwise specified)		
		min.	typ.	max.
I_{CES}	$V_{GE} = 0 \text{ V}; V_{CE} = 600 \text{ V}$			1 mA
I_{GES}	$V_{CE} = 0 \text{ V}; V_{GE} = 25 \text{ V}$			100 nA
$V_{GE(th)}$	$V_{GE} = V_{CE}; I_C = 0.35 \text{ mA}$	4.5	5.5	6.5 V
$V_{(BR)CES}$	$V_{GE} = 0 \text{ V}; I_C = 10 \text{ mA}; T_{VJ} = -40^{\circ}\text{C}$	600		V
$V_{CE(sat)}$	$V_{GE} = 15 \text{ V}; I_C = 10 \text{ A}; T_{VJ} = 25^{\circ}\text{C}$ $T_{VJ} = 125^{\circ}\text{C}$		2.1	2.5 V
			2.4	2.8 V
t_f	$\left. \begin{array}{l} \text{Inductive load, } T_{VJ} = 125^{\circ}\text{C} \\ V_{CC} = 300 \text{ V}; I_C = 10 \text{ A} \\ R_G = 100 \Omega; V_{GE} = \pm 15 \text{ V} \end{array} \right\}$		25	ns
		t_r	25	ns
$t_{d(on)}$		35	ns	
$t_{d(off)}$		250	ns	
E_{off}		0.38	mJ	
E_{on}	0.58	mJ		
C_{iss}	$\left. \begin{array}{l} V_{GE} = 0 \text{ V} \\ V_{CE} = 25 \text{ V} \\ f = 1 \text{ MHz} \end{array} \right\}$		570	pF
		C_{oss}	80	pF
		C_{rss}	55	pF
g_{fs}	$V_{CE} = 20 \text{ V}; I_C = 10 \text{ A}$	3		S
Q_g	$V_{CC} = 300 \text{ V}; I_C = 10 \text{ A pulse}; V_{GE} = 15 \text{ V}$		39	nC
V_F	$I_F = 10 \text{ A}; V_{GE} = 0 \text{ V}; T_{VJ} = 25^{\circ}\text{C}$ $T_{VJ} = 125^{\circ}\text{C}$		2	V
			1.8	V
t_{rr}	$I_F = 10 \text{ A}; V_R = -300 \text{ V}; V_{GE} = 0 \text{ V}$ $di_F/dt = -350 \text{ A}/\mu\text{s}; T_{VJ} = 100^{\circ}\text{C}$		0.2	μs
Q_r	$I_F = 10 \text{ A}; V_R = -300 \text{ V}; T_{VJ} = 25^{\circ}\text{C}$ $di_F/dt = -350 \text{ A}/\mu\text{s}; V_{GE} = 0 \text{ V}; T_{VJ} = 125^{\circ}\text{C}$		0.3	μC
			0.9	μC
I_r				250 μA
R_{thJC}	IGBT (per die)		1.7	$^{\circ}\text{C}/\text{W}$
	Diode (per die)		2.3	$^{\circ}\text{C}/\text{W}$

Brake Chopper T7, D7

Symbol	Conditions	Maximum Ratings	
V_{CES}	$T_{VJ} = 25^{\circ}\text{C}$	600	V
V_{CGR}	$T_{VJ} = 25^{\circ}\text{C}; R_{GE} = 20\text{k}\Omega$	600	V
V_{GE}	$T_{VJ} = 25^{\circ}\text{C}$	± 20	V
I_C	$T_C = 25^{\circ}\text{C}$	11	A
	$T_C = 90^{\circ}\text{C}$	8	A
I_{CM}	$t_p = 1 \text{ ms} = 1\% \text{ duty cycle}; T_C = 25^{\circ}\text{C}$	22	A
		$T_C = 90^{\circ}\text{C}$	16
t_{sc}	IGBT $V_{CE} = 600 \text{ V}; T_{VJ} = 125^{\circ}\text{C}$ non-repetitive	10	μs
P_{tot}	$T_C = 25^{\circ}\text{C}$	45	W
T_{VJ}	Free-Wheeling Diode	+150	$^{\circ}\text{C}$
T_{VJ}	IGBT	+150	$^{\circ}\text{C}$

Symbol	Conditions	Characteristic Values ($T_{VJ} = 25^{\circ}\text{C}$, unless otherwise specified)		
		min.	typ.	max.
I_{CES}	$V_{GE} = 0 \text{ V}; V_{CE} = 600 \text{ V}$			20 μA
I_{GES}	$V_{CE} = 0 \text{ V}; V_{GE} = 25 \text{ V}$			100 nA
$V_{GE(th)}$	$V_{GE} = V_{CE}; I_C = 0.5 \text{ mA}$	3	4	5 V
$V_{(BR)CES}$	$V_{GE} = 0 \text{ V}; I_C = 0.5 \text{ mA}; T_{VJ} = -40^{\circ}\text{C}$	600		V
$V_{CE(sat)}$	$V_{GE} = 15 \text{ V}; I_C = 6 \text{ A}; T_{VJ} = 25^{\circ}\text{C}$ $T_{VJ} = 150^{\circ}\text{C}$		2	2.5 V
			2.3	2.8 V
t_f t_r	Inductive load, $T_{VJ} = 150^{\circ}\text{C}$		75	110 ns
			30	45 ns
$t_{d(on)}$ $t_{d(off)}$	$V_{CC} = 400 \text{ V}; I_C = 6 \text{ A}$ $R_G = 50 \Omega; V_{GE} = \pm 15 \text{ V}$		50	80 ns
			250	375 ns
E_{off}			0.21	mJ
E_{on}			0.25	mJ
C_{iss} C_{oss} C_{rss}	$V_{GE} = 0 \text{ V}$ $V_{CE} = 25 \text{ V}$ $f = 1 \text{ MHz}$		350	435 pF
			40	50 pF
			25	30 pF
g_{fs}	$V_{CE} = 20 \text{ V}; I_C = 6 \text{ A}$	4.2		S
Q_g	$V_{CC} = 400 \text{ V}; I_C = 6 \text{ A pulse}; V_{GE} = 15 \text{ V}$		32.5	nC
V_F	$I_F = 10 \text{ A}; V_{GE} = 0 \text{ V}; T_{VJ} = 25^{\circ}\text{C}$ $T_{VJ} = 150^{\circ}\text{C}$		2	V
			1.8	V
t_{rr}	$I_F = 10 \text{ A}; V_R = -300 \text{ V}; V_{GE} = 0 \text{ V}$ $di_F/dt = -350 \text{ A}/\mu\text{s}; T_{VJ} = 150^{\circ}\text{C}$		0.2	μs
Q_r	$I_F = 10 \text{ A}; V_R = -300 \text{ V}; T_{VJ} = 25^{\circ}\text{C}$ $di_F/dt = -350 \text{ A}/\mu\text{s}; V_{GE} = 0 \text{ V}; T_{VJ} = 125^{\circ}\text{C}$		0.3	μC
			0.9	μC
I_r				250 μA
R_{thJC}	IGBT (per die)		2.3	$^{\circ}\text{C}/\text{W}$
	Diode (per die)		2.3	$^{\circ}\text{C}/\text{W}$

Module

Symbol	Conditions	Maximum Ratings	
T_{stg}		-40...+125	°C
V_{ISOL}	$I_{ISOL} \leq 1 \text{ mA}$; 50/60 Hz; $t = 1 \text{ min}$	2500	V~
M_d	Mounting torque (M4)	2.0 - 2.2 18 - 20	Nm lb.in.
d_s	Creepage distance on surface	12.7	mm
d_A	Strike distance in air	12.7	mm
Weight	typ.	42	g

Temperature Sensor R

Symbol	Conditions	Maximum Ratings	
R	$T_{amb} = 20^\circ\text{C}$	4.7	k Ω

For additional data see C620/4.7k 5% S+M NTC thermistor catalog

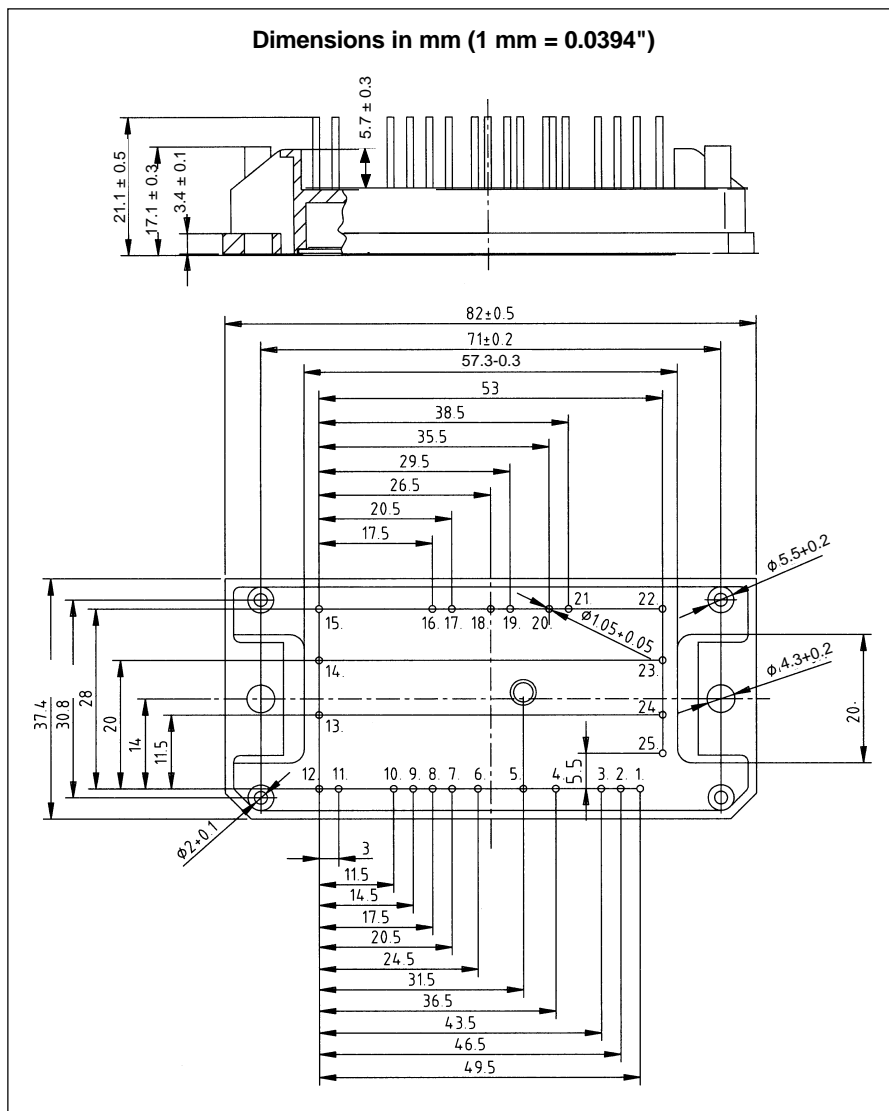

Input Rectifier Bridge D8 - D13

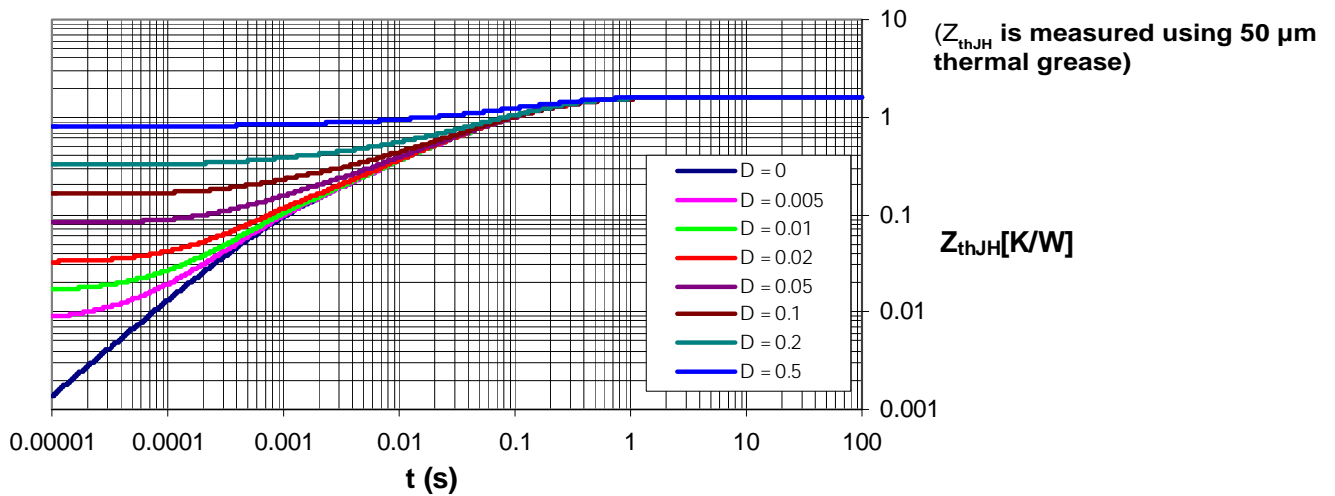
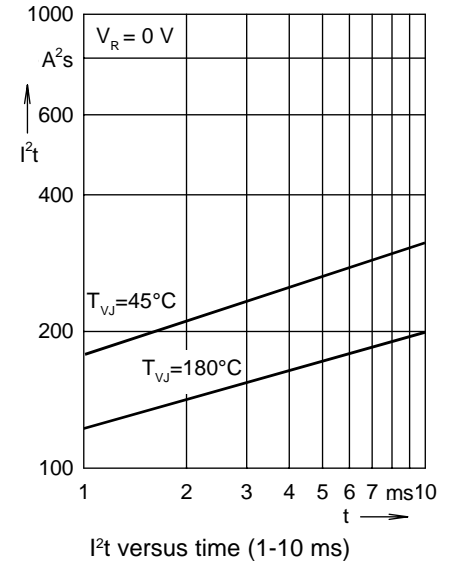
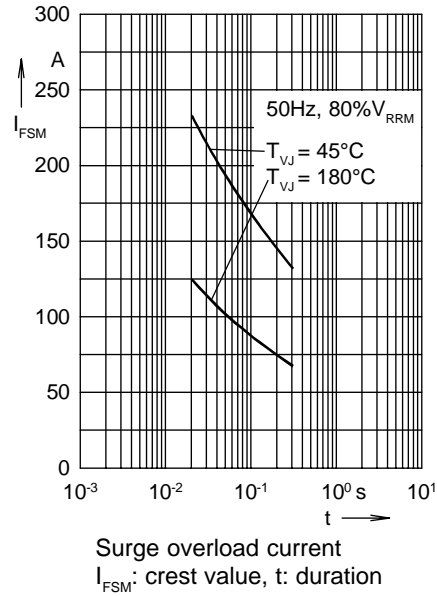
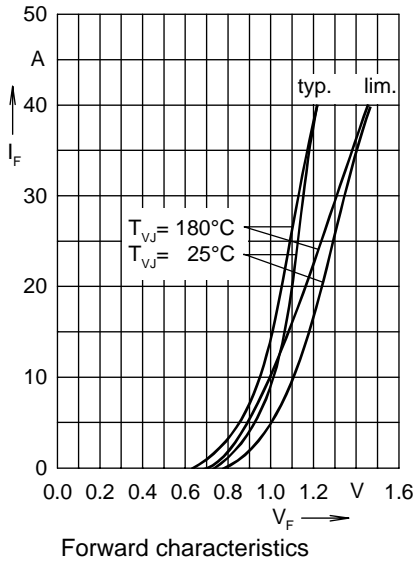

Output Inverter T1 - T6

Typ. output characteristics

$$I_C = f(V_{CE})$$

parameter: $t_p = 250 \mu s$; $T_j = 25^\circ C$

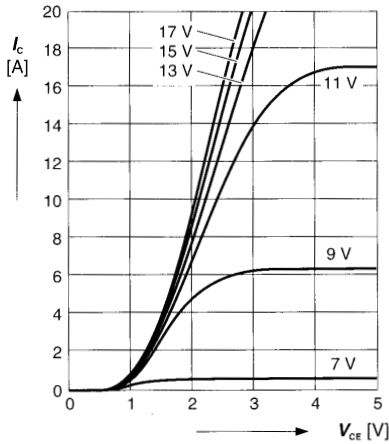

Typ. output characteristics

$$I_C = f(V_{CE})$$

parameter: $t_p = 250 \mu s$; $T_j = 125^\circ C$

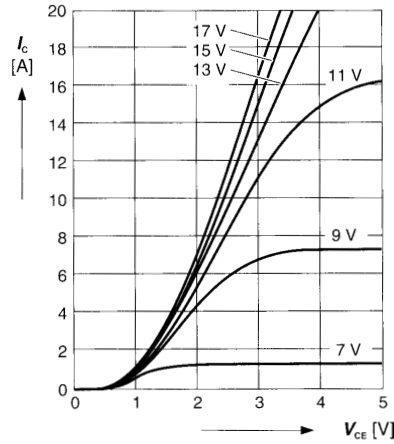

Typ. gate charge

$$V_{GE} = f(Q_g)$$

parameter: $I_{C\ pulis} = 10\ A$

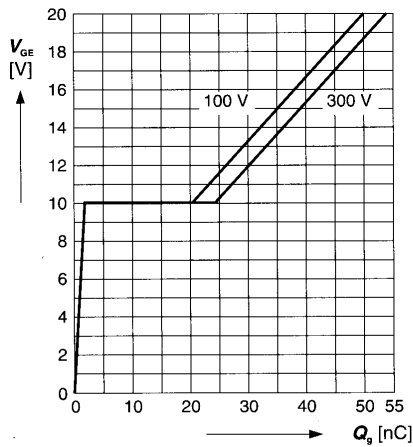

Typ. capacitances

$$C = f(V_{CE})$$

parameter: $V_{GE} = 0\ V$; $f = 1\ MHz$

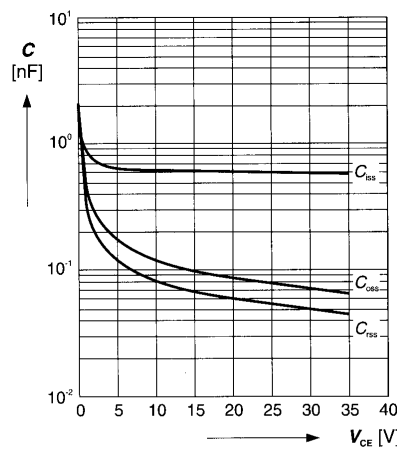

Reverse biased safe operating area

$$I_{C\ pulis} = f(V_{CE}), T_j = 150^\circ C$$

parameter: $V_{GE} = 15\ V$

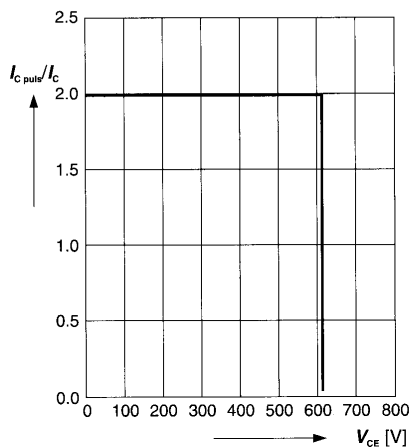

Short circuit safe operating area

$$I_{Csc} = f(V_{CE}), T_j = 150^\circ C$$

parameter: $V_{GE} = \pm 15\ V$; $t_{sc} \le 10\ \mu s$; $L < 60\ nH$

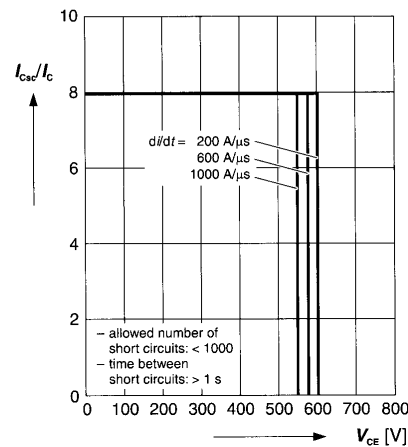

Output Inverter T1 - T6

Typ. switching time

$t = f(I_C)$, inductive load, $T_j = 125^\circ\text{C}$
 parameter: $V_{CE} = 300\text{ V}$; $V_{GE} = \pm 15\text{ V}$; $R_G = 100\ \Omega$

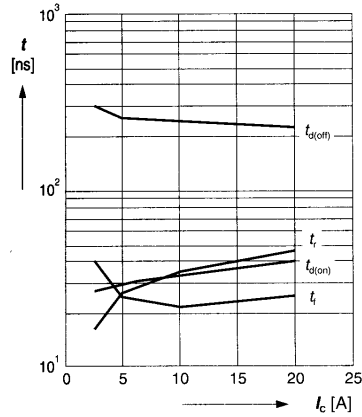

Typ. switching time

$t = f(R_G)$, inductive load, $T_j = 125^\circ\text{C}$
 parameter: $V_{CE} = 300\text{ V}$; $V_{GE} = \pm 15\text{ V}$; $I_C = 10\text{ A}$

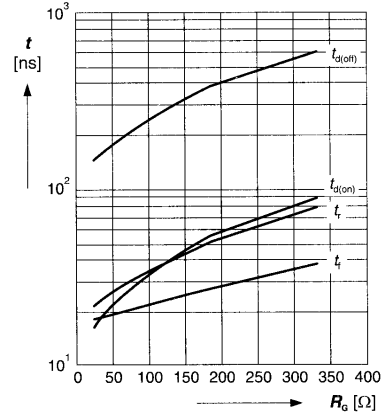

Typ. switching losses

$E = f(I_C)$, inductive load, $T_j = 125^\circ\text{C}$
 parameter: $V_{CE} = 300\text{ V}$; $V_{GE} = \pm 15\text{ V}$; $R_G = 100\ \Omega$

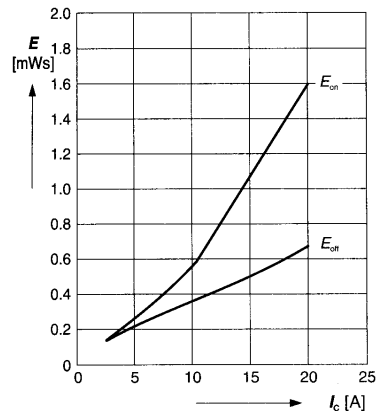

Typ. switching losses

$E = f(R_G)$, inductive load, $T_j = 125^\circ\text{C}$
 parameter: $V_{CE} = 300\text{ V}$; $V_{GE} = \pm 15\text{ V}$; $I_C = 10\text{ A}$

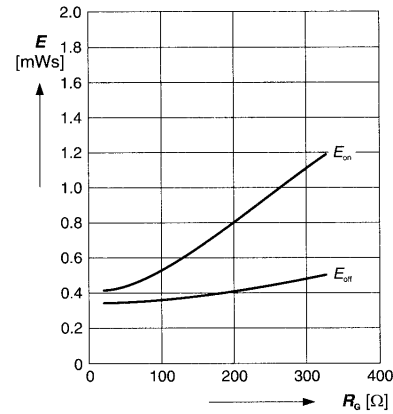

Transient thermal resistance junction to heatsink

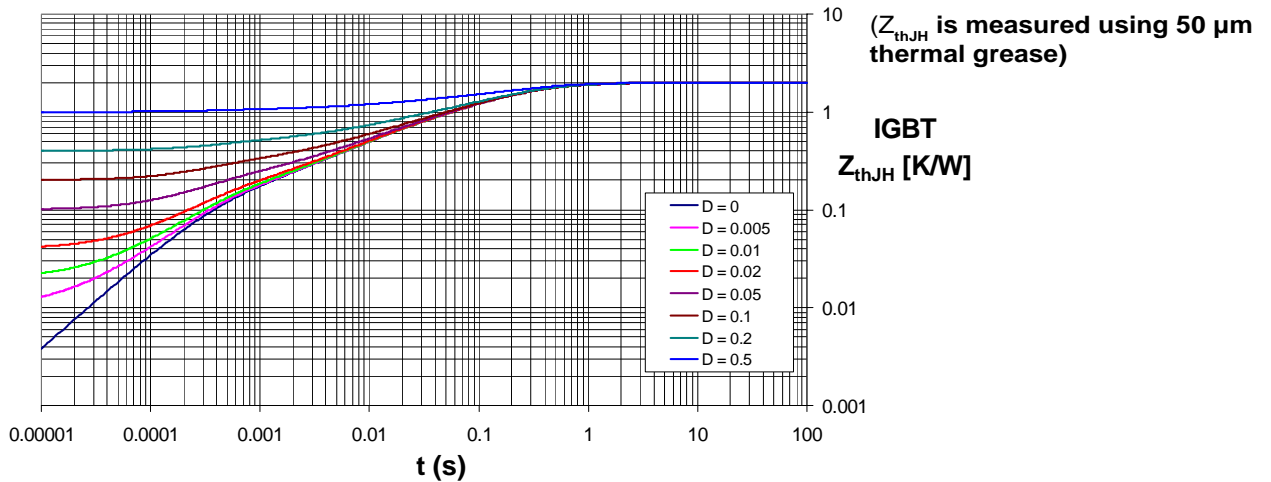

Output Inverter D1 - D6

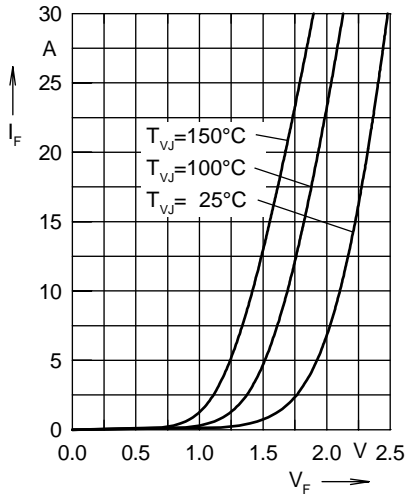

Forward current I_F versus V_F

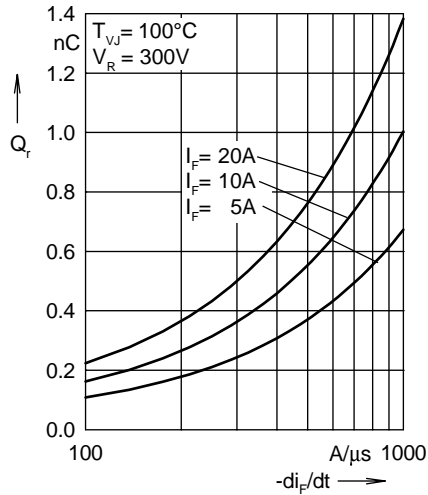

Reverse recovery charge Q_r versus $-di_F/dt$

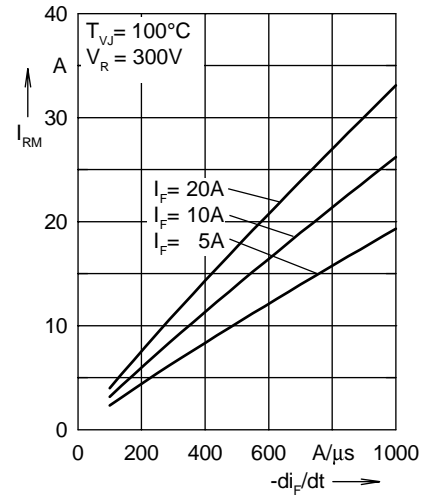

Peak reverse current I_{RM} versus $-di_F/dt$

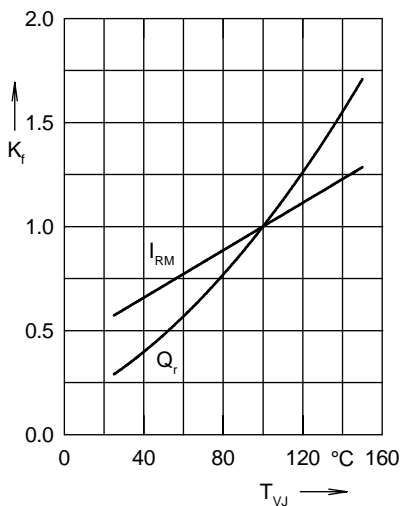

Dynamic parameters Q_r , I_{RM} versus T_{VJ}

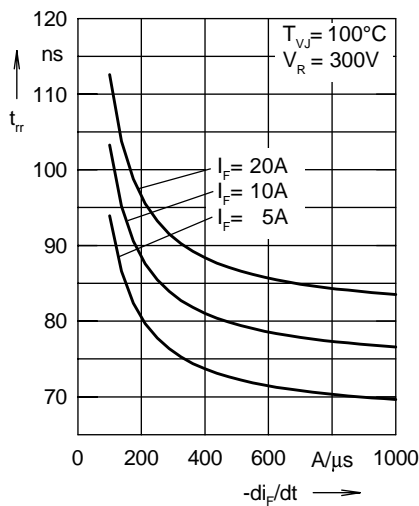

Recovery time t_{rr} versus $-di_F/dt$

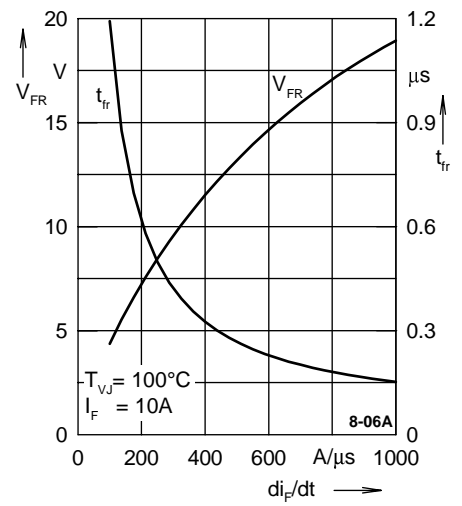

Peak forward voltage V_{FR} and t_{fr} versus di_F/dt

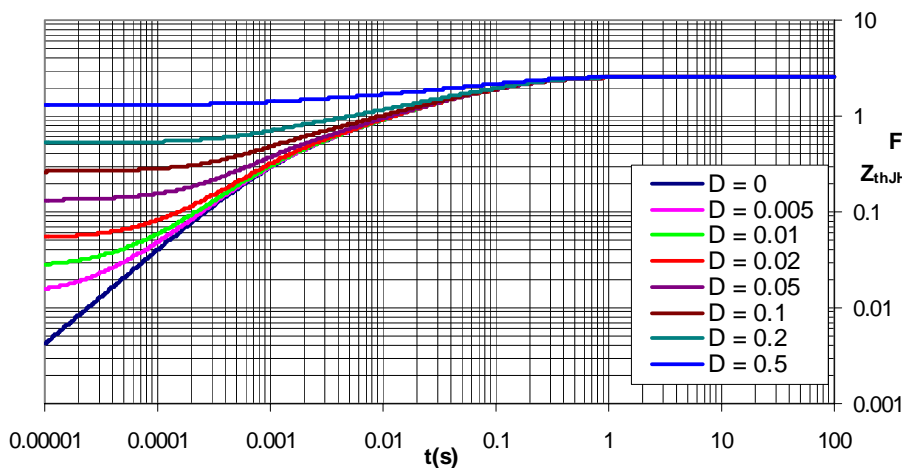

Transient thermal resistance junction to heatsink

(Z_{thJH} is measured using 50 μm thermal grease)

Fred
 Z_{thJH} [K/W]