

FAIRCHILD
SEMICONDUCTOR™

**CLEAR LENS T-100
SOLID STATE LAMPS**

**YELLOW MV5362X TINTED, HLMP-1440, MV5360 PALE TINT
HIGH EFFICIENCY GREEN MV5462X TINTED, HLMP-1540, MV5460 PALE TINT
HIGH EFFICIENCY RED MV5762X TINTED, HLMP-1340, MV5760 PALE TINT**

PACKAGE DIMENSIONS

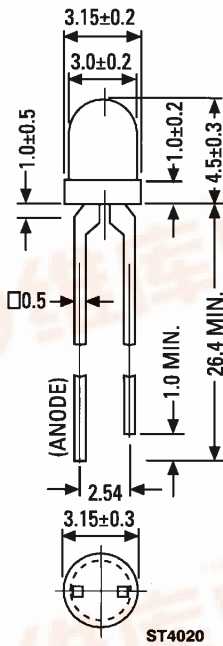

NOTES:
1. ALL DIMENSIONS ARE IN MM.
2. LEAD SPACING IS MEASURED WHERE THE LEADS EMERGE FROM THE PACKAGE.
3. PROTRUDED RESIN UNDER THE FLANGE IS 1.5 mm (0.059") MAX.

ST4020

DESCRIPTION

These solid state indicators offer a variety of color selection. The High Efficiency Red and Yellow devices are made with gallium arsenide phosphide on gallium phosphide. All are encapsulated in epoxy packages and have clear lenses. Their small size, wide viewing angle, and small square leads contribute to their versatility as all-purpose indicators. All types are tinted to aid identification.

FEATURES

- Standard and Ultrabright devices
- Clear tinted lenses
- 100 mil lead spacing
- High efficiency GaP
- Versatile mounting on PC board or panel
- Long life—solid state reliability
- Low power requirements
- Compact, rugged, lightweight
- T-1 diameter
- Replacement for the HLMP-1X20/1 Series
- Excellent for switch backlighting

PHYSICAL CHARACTERISTICS

TYPE	SOURCE COLOR	LENS EFFECT	LUMINOUS INTENSITY at 25°C (mcd)		TEST CONDITION
			MIN.	TYP.	
Ultrabright HLMP-1440	Yellow	Pale Tint	24.0	60.0	} I _F =20 mA I _F =10 mA
MV5360 (HLMP-1420)	Yellow	Pale Tint	6.0	12.0	
MV53621	Yellow	Tinted	3.0	4.0	
MV53622	Yellow	Tinted	6.0	8.0	
Ultrabright HLMP-1540	High Efficiency Green	Pale Tint	24.0	60.0	} I _F =20 mA
MV5460 (HLMP-1520)	High Efficiency Green	Pale Tint	6.0	12.0	
MV54624 (HLMP-1521)	High Efficiency Green	Tinted	6.0	12.0	
Ultrabright HLMP-1340	High Efficiency Red	Pale Orange Tint	24.0	60.0	} I _F =20 mA I _F =10 mA
MV5760 (HLMP-1320)	High Efficiency Red	Pale Orange Tint	6.0	12.0	
MV57620	High Efficiency Red	Tinted	1.5	2.0	
MV57621	High Efficiency Red	Tinted	3.0	4.0	
MV57622 (HLMP-1321)	High Efficiency Red	Tinted	6.0	12.0	



**CLEAR LENS T-100
SOLID STATE LAMPS**

ELECTRO-OPTICAL CHARACTERISTICS (25°C Free Air Temperature Unless Otherwise Specified)								
PARAMETER	TEST CONDITIONS	UNITS	MV5362X MV5360	MV5462X MV5460	MV5762X MV5760	HLMP-1340	HLMP-1440	HLMP-1540
Forward voltage (V _f)	I _f = 10 mA	V	2.1	2.1*	2.0	2.2*	2.2*	2.2*
typ.			3.0	3.0*	3.0	3.0*	3.0*	3.0*
Peak wavelength		nm	585	565	635	635	585	565
Spectral line half width		nm	35	40	45	45	35	40
Capacitance typ.	f = 1 MHz, V = 0	pF	45	20	45	45	45	20
Reverse voltage (V _r) min.	I _r = 100 μA	V	5.0	5.0	5.0	5.0	5.0	5.0
Viewing angle (total) typ.	See Fig. 3	degrees	45	45	45	45	45	45

*I_r = 20 mA

ABSOLUTE MAXIMUM RATING (T _a = 25°C Unless Otherwise Specified)	
Power dissipation	120 mW
Derate linearly from 50°	0.4 mA/°C
Storage and operating temperature	-55°C to +100°C
Lead soldering time at 260°C (1/16 inch from body)	5 sec.
Continuous forward current (MV5360/MV5362X/HLMP-1440=20 mA)	30 mA
Peak forward current (1 μsec pulse, 0.3% duty cycle) (MV5360/MV5362X/HLMP-1440=60 mA)	90 mA
Reverse voltage	5.0 V

TYPICAL ELECTRO-OPTICAL CHARACTERISTIC CURVES
(25°C Free Air Temperature Unless Otherwise Specified)

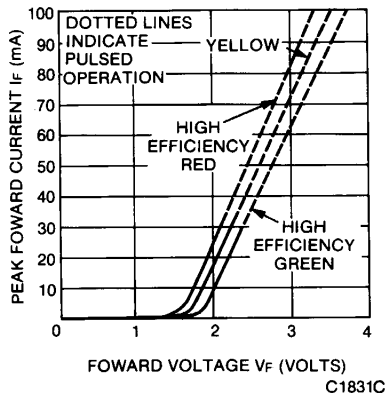
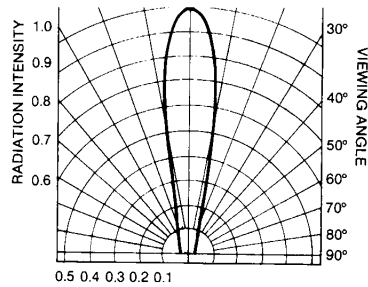

Fig. 1. Forward Current vs. Forward Voltage



C1793

C1793

Fig. 2. Relative Luminous Intensity vs. Forward Current

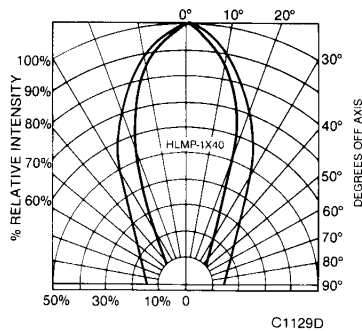

Fig. 3. Spatial Distribution

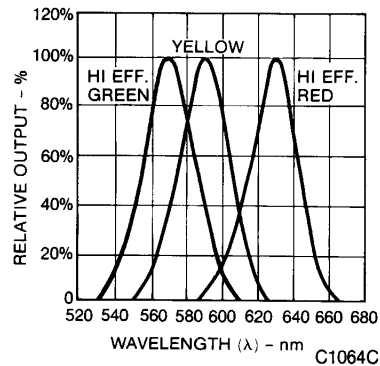

Fig. 4. Spectral Distribution



CLEAR LENS T-100 SOLID STATE LAMPS

DISCLAIMER

FAIRCHILD SEMICONDUCTOR RESERVES THE RIGHT TO MAKE CHANGES WITHOUT FURTHER NOTICE TO ANY PRODUCTS HEREIN TO IMPROVE RELIABILITY, FUNCTION OR DESIGN. FAIRCHILD DOES NOT ASSUME ANY LIABILITY ARISING OUT OF THE APPLICATION OR USE OF ANY PRODUCT OR CIRCUIT DESCRIBED HEREIN; NEITHER DOES IT CONVEY ANY LICENSE UNDER ITS PATENT RIGHTS, NOR THE RIGHTS OF OTHERS.

LIFE SUPPORT POLICY

FAIRCHILD'S PRODUCTS ARE NOT AUTHORIZED FOR USE AS CRITICAL COMPONENTS IN LIFE SUPPORT DEVICES OR SYSTEMS WITHOUT THE EXPRESS WRITTEN APPROVAL OF THE PRESIDENT OF FAIRCHILD SEMICONDUCTOR CORPORATION. As used herein:

1. Life support devices or systems are devices or systems which, (a) are intended for surgical implant into the body, or (b) support or sustain life, and (c) whose failure to perform when properly used in accordance with instructions for use provided in the labeling, can be reasonably expected to result in a significant injury of the user.
2. A critical component in any component of a life support device or system whose failure to perform can be reasonably expected to cause the failure of the life support device or system, or to affect its safety or effectiveness.