

MX-850

Precision, Higher-Speed 4-Channel, Analog Multiplexers

FEATURES

- 50ns settling time to $\pm 0.01\%$
- 70ns settling time to $\pm 0.003\%$
- 100ns settling time to $\pm 0.001\%$
- 4 Channels, single-ended inputs
- 100mW power dissipation
- Small, 14-pin DIP package

GENERAL DESCRIPTION

The MX-850 is a precision, high-speed multiplexer characterized for 10, 12, 14 and 16-bit applications. The performance benchmarks are its 50 nanosecond maximum settling time to $\pm 0.01\%$ accuracy and its unprecedented $\pm 0.001\%$ accuracy specification.

Packaged in a miniature, 14-pin, ceramic DIP, the MX-850 operates from $\pm 15V$ and $+5V$ supplies and consumes a maximum 270mW. Models are available for either 0 to $+70^{\circ}C$ or -55 to $+125^{\circ}C$ operation.

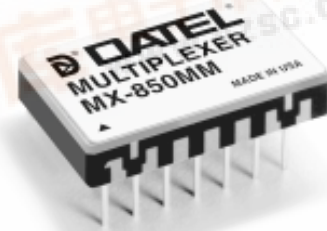

INPUT/OUTPUT CONNECTIONS

PIN	FUNCTION
1	ENABLE
2	A0
3	A1
4	CH1 INPUT
5	CH2 INPUT
6	CH3 INPUT
7	CH4 INPUT
8	OUTPUT
9	GROUND
10	+15V SUPPLY
11	GROUND
12	+5V SUPPLY
13	GROUND
14	-15V SUPPLY

Table 1. Channel Addressing

ON CHANNEL	MUX ADDRESS		
	\overline{EN}	A ₁	A ₀
Disable	1	X	X
1	0	0	0
2	0	0	1
3	0	1	0
4	0	1	1

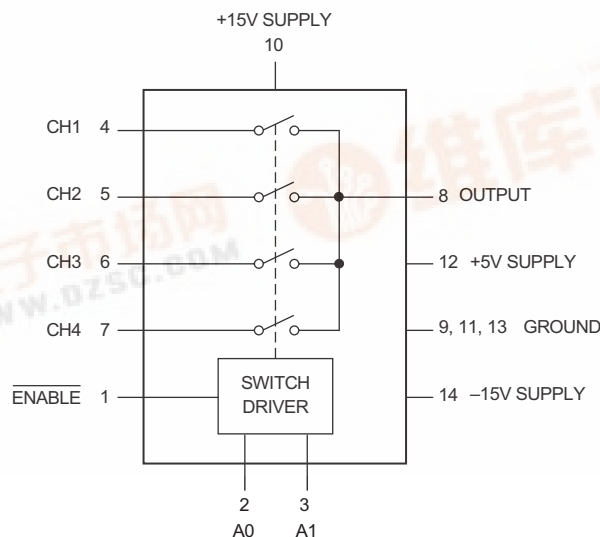

Figure 1. Functional Block Diagram

ABSOLUTE MAXIMUM RATINGS

PARAMETER	LIMITS	UNITS
+15V Supply, Pin 10	-0.5 to +16.5	Volts
-15V Supply, Pin 14	+0.5 to -16.5	Volts
+5V Supply, Pin 12	-0.5 to +7	Volts
Digital Inputs, Pins 1, 2, 3	-0.5 to +6	Volts
Analog Inputs, Pins 4, 5, 6, 7	-10.5 to +10.5	Volts
Analog Input Current	±20	mA
Lead temperature (10 seconds)	300	°C
Switching Frequency/Duty Cycle	10/50	MHz/%

FUNCTIONAL SPECIFICATIONS

(Apply over the operating temperature range and over the operating power supply range unless otherwise specified.)

ANALOG INPUTS	MIN.	TYP.	MAX.	UNITS
Analog Signal Range	±10	—	—	Volts
On Resistance, +25°C	—	18	90	Ohms
0 to +70°C	—	—	120	Ohms
-55 to +125°C	—	—	140	Ohms
R_{ON} versus V_{IN}	See Figure 2			
Input Leakage Current (Off)				
+25°C	—	±0.02	±0.2	nA
0 to +70°C	—	—	±10	nA
-55 to +125°C	—	—	±25	nA
Output Leakage Current (Off)				
+25°C	—	±0.02	±0.2	nA
0 to +70°C	—	—	±20	nA
-55 to +125°C	—	—	±40	nA
On Channel Leakage Current				
+25°C	—	±0.4	±1	nA
0 to +70°C	—	—	±25	nA
-55 to +125°C	—	—	±35	nA
Channel Input Capacitance				
Off	—	4	6	pF
On	—	10	12	pF
Channel Output Capacitance				
On	—	8	10	pF
Nonlinearity	—	—	±0.001	%FSR
Large signal bandwidth (-3dB)	80	100	—	MHz
DIGITAL INPUTS				
Logic levels				
Logic "1"	+2.0	—	—	Volts
Logic "0"	—	—	+0.8	Volts
Logic Loading "1"	—	—	+10	µA
Logic Loading "0"	—	—	-10	µA
SWITCHING CHARACTERISTICS				
Access Time	—	—	20	ns
Break-Before-Make Delay Time	—	—	10	ns
Enable Delay (On, Off)	—	3	10	ns
Settling Time, 10M Load				
10V step to ±0.1%	—	25	30	ns
10V step to ±0.01%	—	40	50	ns
10V step to ±0.003%	—	60	70	ns
10V step to ±0.001%	—	80	100	ns
Settling Time, 5k Load				
10V step to ±0.1%	—	25	30	ns
10V step to ±0.01%	—	40	50	ns
10V step to ±0.003%	—	60	70	ns
10V step to ±0.001%	—	80	100	ns
Settling Time, 10M Load				
20V step to ±0.1%	—	30	35	ns
20V step to ±0.01%	—	50	60	ns
20V step to ±0.003%	—	75	85	ns
20V step to ±0.001%	—	100	120	ns

SWITCHING CHAR. (cont.)	MIN.	TYP.	MAX.	UNITS
Settling Time, 5k Load				
20V step to ±0.1%	—	30	35	ns
20V step to ±0.01%	—	50	60	ns
20V step to ±0.003%	—	75	85	ns
20V step to ±0.001%	—	100	120	ns
Crosstalk ①				
10kHz (20Vp-p)	—	-105	-100	dB
1MHz (20Vp-p)	—	-94	-92	dB
10MHz (5Vp-p)	—	-76	-71	dB
20MHz (3Vp-p)	—	-64	-62	dB

POWER REQUIREMENTS

Power Supply Range	MIN.	TYP.	MAX.	UNITS
+15V Supply	+14.5	+15	+15.5	Volts
-15V Supply	-14.5	-15	-15.5	Volts
+5V Supply	+4.75	+5	+5.25	Volts
Power Supply Current, Quiescent				
+15V Supply	—	+3	+4	mA
-15V Supply	—	-10	-12	mA
+5V Supply	—	+3	+3.5	mA
Power Supply Rejection Ratio	80	90	—	dB
Power Supply Dissipation, Quiescent				
+25°C	—	207	270	mW
0 to +70°C	—	—	270	mW
-55 to +125°C	—	—	280	mW
Pd versus Frequency	See Figure 4			

PHYSICAL/ENVIRONMENTAL

Operating Temp. Range, Case	MIN.	TYP.	MAX.	UNITS
MX-850MC	0	—	+70	°C
MX-850MM	-55	—	+125	°C
Storage Temperature Range	-65	—	+150	°C
Package Type	14-pin, metal-sealed, ceramic DIP			
Weight	0.1 ounces (2.8 grams)			

① See Figures 3a and 3b.

TECHNICAL NOTES

1. Proper operation of the MX-850 multiplexer is dependent upon good board layout and connection practices. Bypass supplies as shown in the connection diagrams. Mount bypass capacitors directly to the supply pins whenever possible.
2. All grounds pins (9, 11, 13) should be tied together and connected to ground as close to the multiplexer as possible.
3. When power is off, current limit input signals on pins 4, 5, 6, and 7 to 20mA. Failure to current limit can cause permanent damage to the device since, when powering up or down it is possible that two switches might be on at the same time. Excessive current (greater than 20mA) will flow from the more positive input to the more negative input, permanently damaging the device. Applications in which the power supply for the multiplexer also powers the signal sources may not require limiting resistors. See Figure 4.

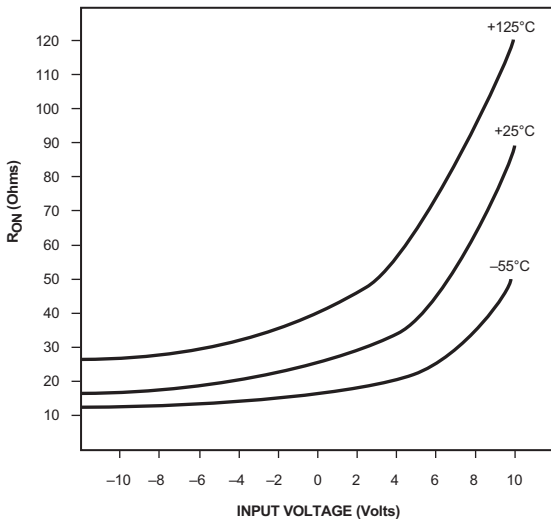

Figure 2. Channel On Resistance Versus Input Voltage

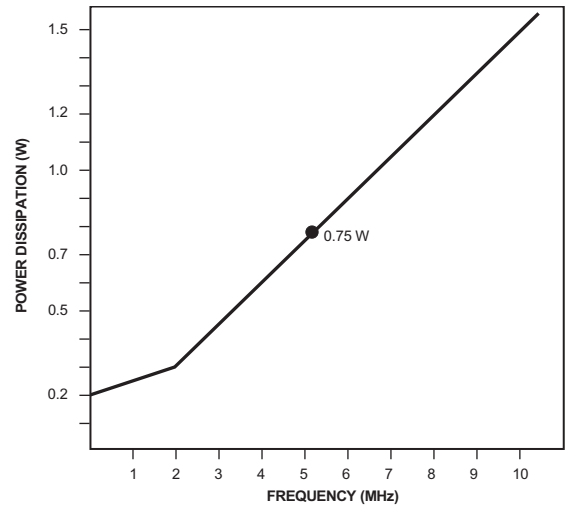

Figure 4. Power Dissipation Versus Switching Frequency

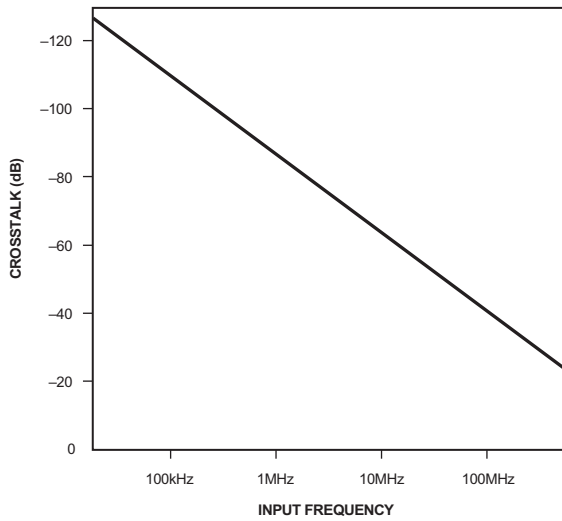

Figure 3a. Small Signal Crosstalk Versus Input Frequency

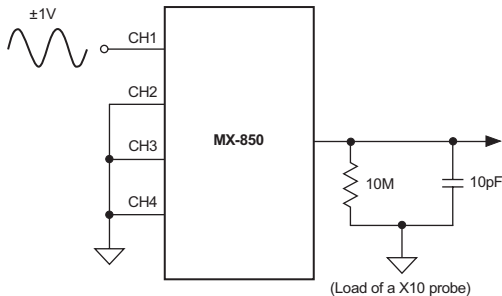

Figure 3b. Crosstalk Test Circuit

CURRENT LIMITING RESISTORS

As noted in Technical Note 3, some current limiting technique must be employed to protect the device. The following lists the suggested resistor values for the current limiting resistors shown in Figure 5.

Input Range	Limiting Resistors
±10V	R = 500Ω
±5V	R = 250Ω
≤±1V	No current limiting needed

Other current limiting circuits can be used, such as a current limited op amp drive, depending upon the application.

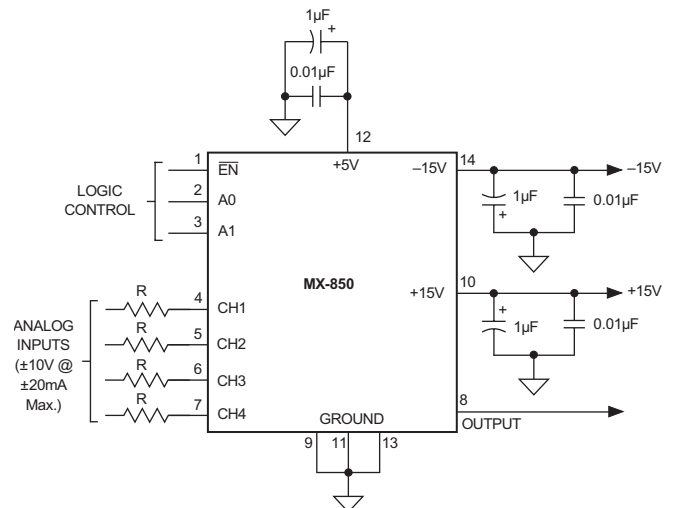

Figure 5. Typical Connections

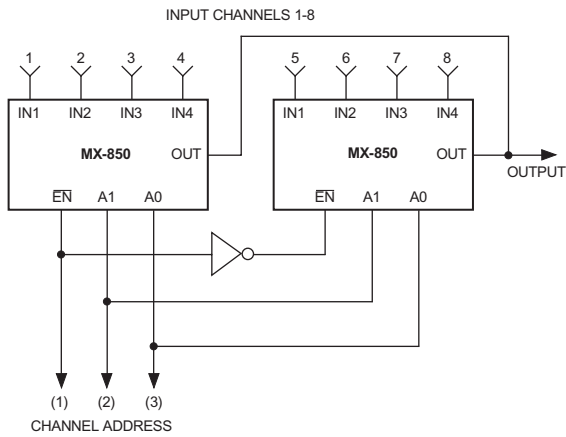

Figure 6. Cascading Multiple MX-850's

Table 2. 8 Channel Addressing

ON CHANNEL	MUX ADDRESS		
	1	2	3
1	0	0	0
2	0	0	1
3	0	1	0
4	0	1	1
5	1	0	0
6	1	0	1
7	1	1	0
8	1	1	1

CHANNEL EXPANSION

The MX-850's ENABLE input provides a means of channel expansion. As shown in Figure 6 and in Table 2, multiple multiplexers may be used by using the ENABLE input as an address line.

MECHANICAL DIMENSIONS
INCHES (mm)

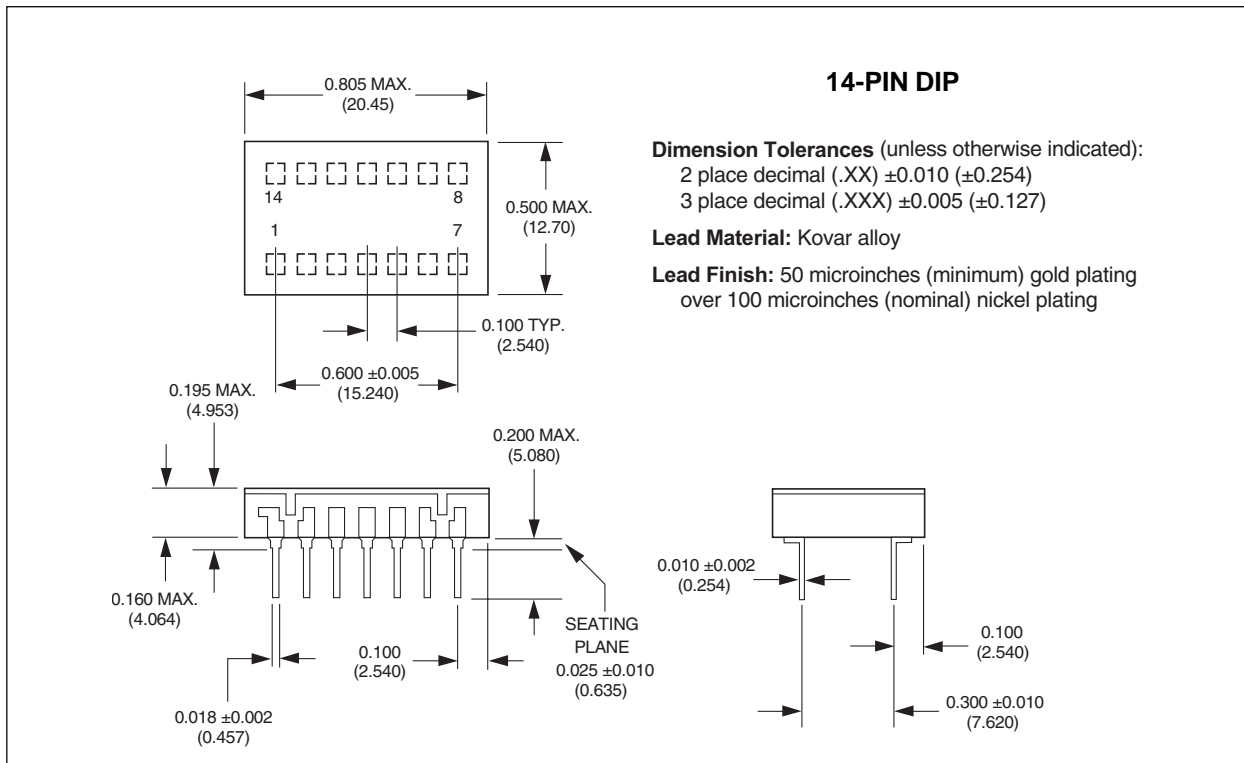

14-PIN DIP

Dimension Tolerances (unless otherwise indicated):
2 place decimal (.XX) ±0.010 (±0.254)
3 place decimal (.XXX) ±0.005 (±0.127)

Lead Material: Kovar alloy

Lead Finish: 50 microinches (minimum) gold plating over 100 microinches (nominal) nickel plating

ORDERING INFORMATION

MODEL	OPERATING TEMP. RANGE
MX-850MC	0 to +70°C
MX-850MM	-55 to +125°C

For availability of a high-reliability (QL) version, contact DATEL.