

## 1M-BIT MASK ROM (8 BIT OUTPUT)

### FEATURES

- Bit organization
  - 128K x 8 (byte mode)
- Fast access time
  - Random access: 45ns (max.)
- Current
  - Operating: 40mA
  - Standby: 100uA
- Supply voltage
  - $5V \pm 10\%$  for 70ns(max.)
  - $5V \pm 5\%$  for 45ns(max.)
- Package
  - 32 pin PDIP/SOP/PLCC/TSOP

### PIN CONFIGURATION

#### 32 PDIP

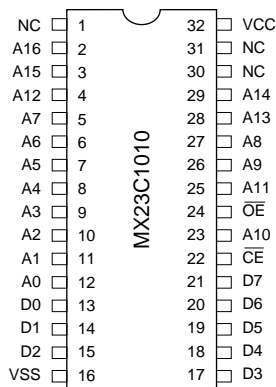

#### 32 SOP

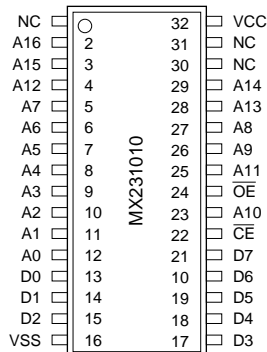

### ORDER INFORMATION

Part No.	Access Time	Package
MX23C1010PC-45	45ns	32 pin PDIP
MX23C1010PC-70	70ns	32 pin PDIP
MX23C1010PC-90	90ns	32 pin PDIP
MX23C1010PC-10	100ns	32 pin PDIP
MX23C1010PC-12	120ns	32 pin PDIP
MX23C1010PC-15	150ns	32 pin PDIP
MX23C1010MC-45	45ns	32 pin SOP
MX23C1010MC-70	70ns	32 pin SOP
MX23C1010MC-90	90ns	32 pin SOP
MX23C1010MC-10	100ns	32 pin SOP
MX23C1010MC-12	120ns	32 pin SOP
MX23C1010MC-15	150ns	32 pin SOP
MX23C1010QC-45	45ns	32 pin PLCC
MX23C1010QC-70	70ns	32 pin PLCC
MX23C1010QC-90	90ns	32 pin PLCC
MX23C1010QC-10	100ns	32 pin PLCC
MX23C1010QC-12	120ns	32 pin PLCC
MX23C1010QC-15	150ns	32 pin PLCC
MX23C1010TC-45	45ns	32 pin TSOP
MX23C1010TC-70	70ns	32 pin TSOP
MX23C1010TC-90	90ns	32 pin TSOP
MX23C1010TC-10	100ns	32 pin TSOP
MX23C1010TC-12	120ns	32 pin TSOP
MX23C1010TC-15	150ns	32 pin TSOP
MX23C1010QI-12(*)	120ns	32 pin PLCC
MX23C1010QI-15(*)	150ns	32 pin PLCC
MX23C1010TI-90(*)	90ns	32 pin TSOP

(\*): industrial grade, TA= -40° C ~ 85° C

### PIN DESCRIPTION

Symbol	Pin Function
A0~A16	Address Inputs
D0~D7	Data Outputs
CE	Chip Enable Input
OE	Output Enable Input
VCC	Power Supply Pin
VSS	Ground Pin
NC	No Connection

### 32 TSOP(I)

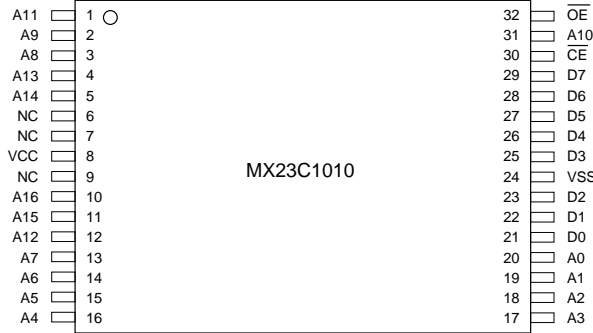

### 32 PLCC

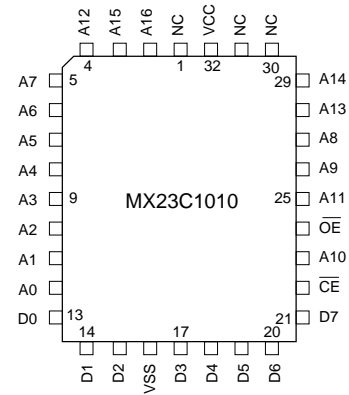

### ABSOLUTE MAXIMUM RATINGS

ITEM	SYMBOL	RATINGS
Voltage on any Pin Relative to VSS	VIN	-0.5V to 7.0V
Ambient Operating Temperature	Topr	-40°C to 85°C
Storage Temperature	Tstg	-65°C to 125°C

### DC CHARACTERISTICS (Ta = -40°C ~ 85°C, VCC = 5V±10% for 70ns max., 5V±5% for 45ns max.)

ITEM	SYMBOL	MIN.	MAX.	CONDITIONS
Output High Voltage	VOH	2.4V	-	IOH = -0.4mA
Output Low Voltage	VOL	-	0.4V	IOL = 2.1mA
Input High Voltage	VIH	2.0V	VCC+0.5V	
Input Low Voltage	VIL	-0.3V	0.8V	
Input Leakage Current	ILI	-10	10uA	VIN=0 to 5.5V
Output Leakage Current	ILO	-10	10uA	VOUT=0 to 5.5V
Operating Current	ICC1	-	40mA	CE = VIL, f = 5MHz, Iout = 0mA
Standby Current (TTL)	ISTB1	-	1.5mA	CE = VIH
Standby Current (CMOS)	ISTB2	-	100uA	CE = VCC +/- 0.3V
Input Capacitance	CIN	-	12pF	VIN=0V
Output Capacitance	COUT	-	12pF	VOUT=0V

## AC CHARACTERISTICS (Ta = -40°C ~ 85°C, VCC = 5V±10% for 70ns max., 5V±5% for 45ns max.)

ITEM	SYMBOL	23C1010-45*		23C1010-70*		23C1010-90		23C1010-10		23C1010-12		23C1010-15	
		MIN.	MAX.	MIN.	MAX.	MIN.	MAX.	MIN.	MAX.	MIN.	MAX.	MIN.	MAX.
Read Cycle Time	tRC	45ns	-	70ns	-	90ns	-	100ns	-	120ns	-	150ns	-
Address Access Time	tAA	-	45ns	-	70ns	-	90ns	-	100ns	-	120ns	-	150ns
Chip Enable Access Time	tACE	-	45ns	-	70ns	-	90ns	-	100ns	-	120ns	-	150ns
Output Enable Time	tOE	-	25ns	-	35ns	-	40ns	-	45ns	-	50ns	-	60ns
Output Hold After Address	tOH	0ns	-	0ns	-	0ns	-	0ns	-	0ns	-	0ns	-
Output High Z Delay	tHZ	-	17ns	-	20ns	-	25ns	-	30ns	-	35ns	-	50ns

Note :Output high-impedance delay (tHZ) is measured from  $\overline{OE}$  or  $\overline{CE}$  going high, and this parameter guaranteed by design over the full voltage and temperature operating range - not tested.

\*45ns&70ns speed grades are under development.

## AC Test Conditions

Input Pulse Levels	0.4V~2.4V 0V~3v (for 45ns&70ns)
Input Rise and Fall Times	10ns
Input Timing Level	0.8V~2.0V 1.5V (for 45ns&70ns)
Output Timing Level	0.8V and 2.0V 1.5V (for 45ns&70ns)
Output Load	See Figure

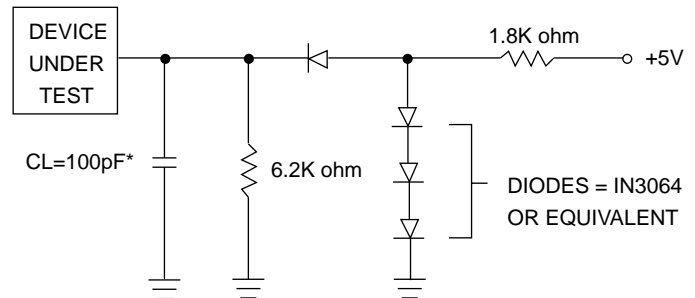

\*CL=30pF for 45ns&70ns

## TIMING DIAGRAM

### RANDOM READ

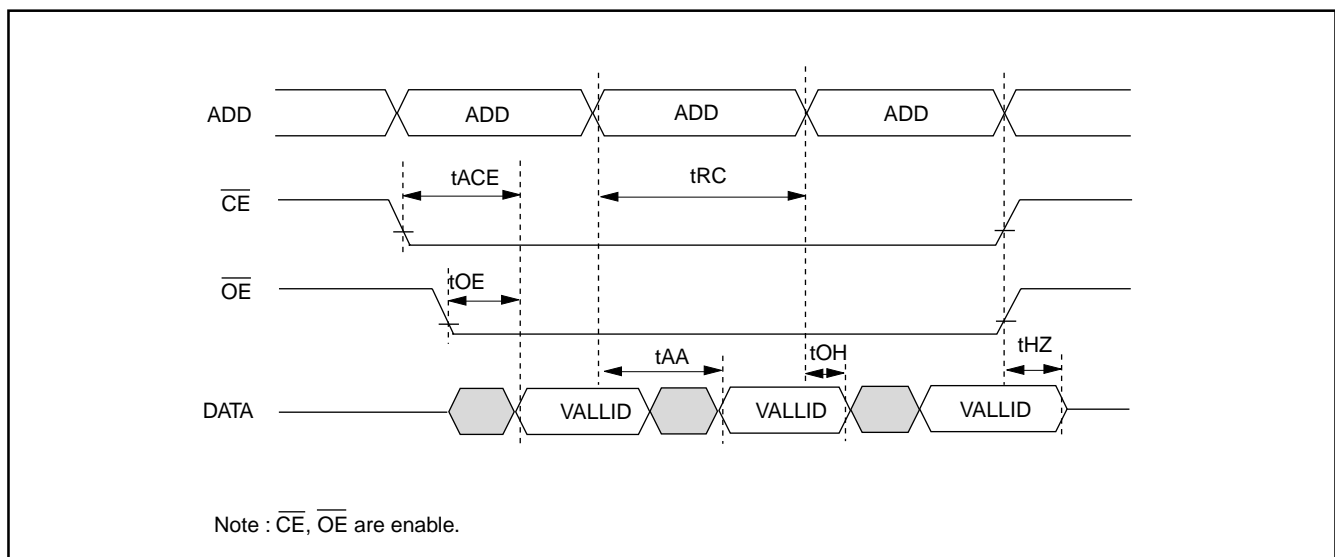

## PACKAGE INFORMATION

### 32-PIN PLASTIC DIP (600 mil)

ITEM	MILLIMETERS	INCHES
A	42.13 max.	1.660 max.
B	1.90 [REF]	.075 [REF]
C	2.54 [TP]	.100 [TP]
D	.46 [Typ.]	.018 [Typ.]
E	38.07	1.500
F	1.27 [Typ.]	.050 [Typ.]
G	3.30±.25	.130±.010
H	.51 [REF]	.020 [REF]
I	3.94±.25	.155±.010
J	5.33 max.	.210 max.
K	15.22±.25	.600±.010
L	13.97±.25	.550±.010
M	.25 [Typ.]	.010 [Typ.]

**NOTE:** Each lead centerline is located within .25 mm [.01 inch] of its true position [TP] at maximum material condition.

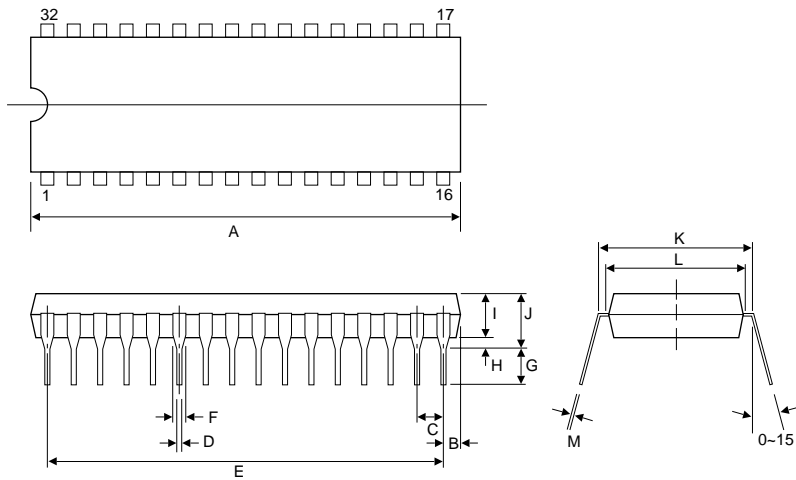

### 32-PIN PLASTIC SOP (450 mil)

ITEM	MILLIMETERS	INCHES
A	20.95 max.	.825 max.
B	1.00 [REF]	.039 [REF]
C	1.27 [TP]	.050 [TP]
D	.40 [Typ.]	.016 [Typ.]
E	.05 min.	.002 min.
F	3.05 max.	.120 max.
G	2.69±.13	.106±.005
H	14.12±.25	.556±.010
I	11.30±.13	.445±.005
J	1.42	.056
K	.20 [Typ.]	.008 [Typ.]
L	.79	.031

**NOTE:** Each lead centerline is located within .25 mm [.01 inch] of its true position [TP] at maximum material condition.

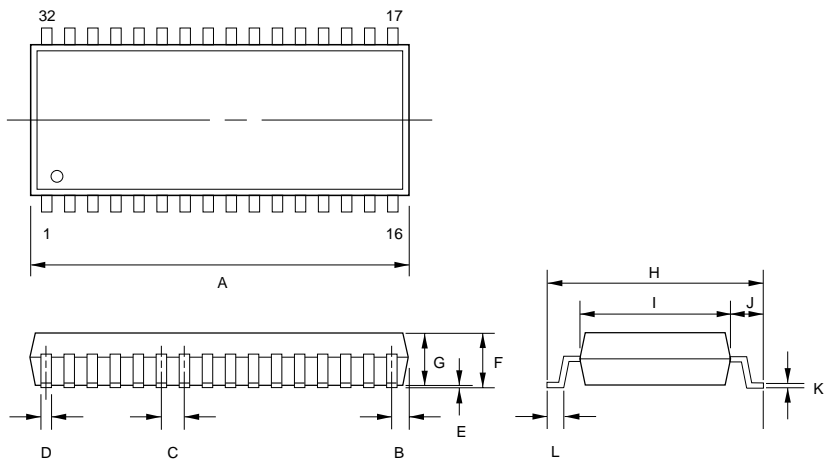

## 32-PIN PLASTIC TSOP

ITEM	MILLIMETERS	INCHES
A	20.0±.20	.788±.006
B	18.40±.10	.724±.004
C	8.20 max.	.323 max.
D	.15 [Typ.]	.006 [Typ.]
E	.80 [Typ.]	.031 [Typ.]
F	.20±.10	.008±.004
G	.30±.10	.012±.004
H	.50 [Typ.]	.020 [Typ.]
I	.45 max.	.018 max.
J	0 ~ .20	0 ~ .008
K	1.00±.10	.039±.004
L	1.27 max.	.050 max.
M	.50	.020
N	0 ~ 5°	.500

**NOTE:** Each lead centerline is located within .25 mm [.01 inch] of its true position [TP] at maximum material condition.

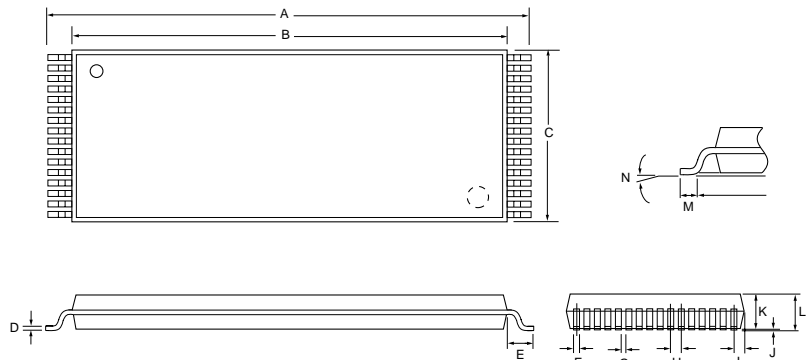

## 32-PIN PLASTIC LEADED CHIP CARRIER (PLCC)

ITEM	MILLIMETERS	INCHES
A	12.44±.13	.490±.005
B	11.50±.13	.453±.005
C	14.04±.13	.553±.13
D	14.98±.13	.590±.13
E	1.93	.076
F	3.30±.25	.130±.010
G	2.03±.13	.080±.005
H	.51±.13	.020±.005
I	1.27 [Typ.]	.050 [Typ.]
J	.71 [REF]	.028 [REF]
K	.46 [REF]	.018 [REF]
L	10.40/12.94	.410/.510
	(W) (L)	(W) (L)
M	.89 R	.035 R
N	.25 [TYP.]	.010 [TYP.]

**NOTE:** Each lead centerline is located within .25 mm [.01 inch] of its true position [TP] at maximum material condition.

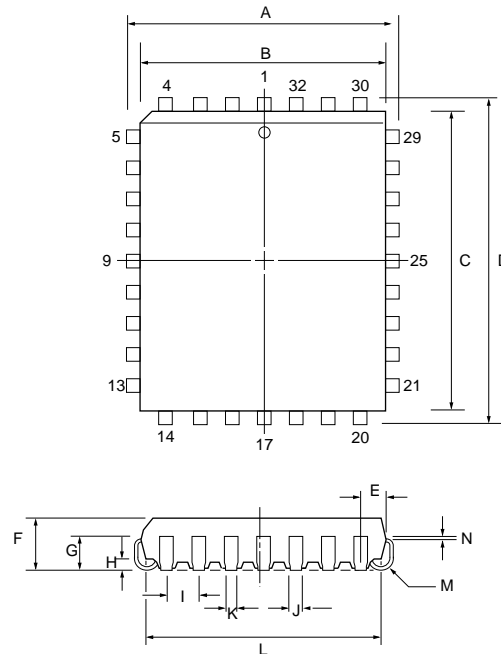

**REVISION HISTORY**

<b>REVISION</b>	<b>DESCRIPTION</b>	<b>PAGE</b>	<b>DATE</b>
3.9	To add 70ns speed grade	P2	NOV/23/1998
4.0	To add 45ns speed grade	P2	DEC/10/1998



**MX23C1010**

---

---

**MACRONIX INTERNATIONAL Co., LTD.**

**HEADQUARTERS:**

TEL:+886-3-578-8888

FAX:+886-3-578-8887

**EUROPE OFFICE:**

TEL:+32-2-456-8020

FAX:+32-2-456-8021

**JAPAN OFFICE:**

TEL:+81-44-246-9100

FAX:+81-44-246-9105

**SINGAPORE OFFICE:**

TEL:+65-747-2309

FAX:+65-748-4090

**TAIPEI OFFICE:**

TEL:+886-3-509-3300

FAX:+886-3-509-2200

**MACRONIX AMERICA, INC.**

TEL:+1-408-453-8088

FAX:+1-408-453-8488

**CHICAGO OFFICE:**

TEL:+1-847-963-1900

FAX:+1-847-963-1909

**[http : //www.macronix.com](http://www.macronix.com)**

Copyright © Each Manufacturing Company.

All Datasheets cannot be modified without permission.

This datasheet has been download from :

[www.AllDataSheet.com](http://www.AllDataSheet.com)

100% Free DataSheet Search Site.

Free Download.

No Register.

Fast Search System.

[www.AllDataSheet.com](http://www.AllDataSheet.com)