

MAXIM Pin Programmable Precision Voltage Reference

MX584

General Description

Maxim's MX584 is a temperature compensated, bandgap voltage reference which provides pin-programmable output voltages of +10.00V, +7.50V, +5.00V, and +2.50V. External components are not required for these outputs, but if other voltages are desired, they can be programmed with external resistors.

Laser trimming minimizes output error as well as temperature drift, to as low as 10mV and 15ppm/°C with the MX584K.

The input voltage range of the MX584 is 4.5V to 30V. The reference also includes a STROBE input which shuts down the reference output. Typical current drain when ON is 750µA. This drops to about 100µA when the reference is strobed OFF.

The MX584 is designed for use with 8 to 14 bit A/D and D/A converters as well as data acquisition systems. It is available in 8-lead TO-99 metal cans, plastic DIPs, CERDIPs, and small outline packages.

Applications

- CMOS DAC Reference
- A/D Converter Reference
- Measurement Instrumentation
- Data Loggers
- Precision Analog Systems
- Programmable Offset for PGAs

Pin Configuration

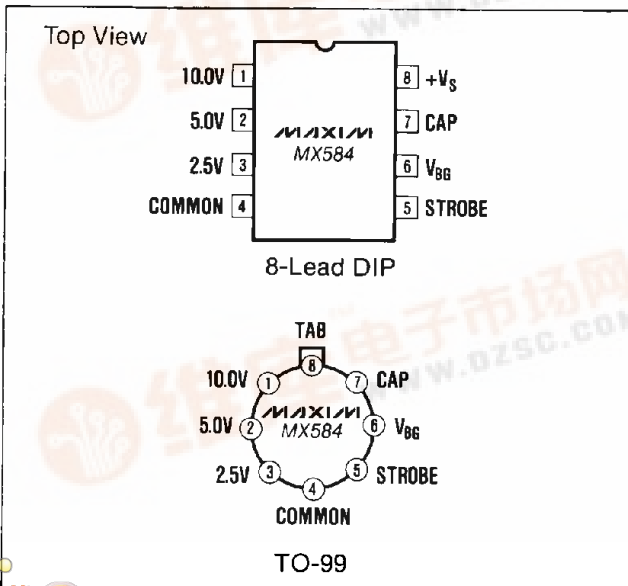

Features

- ◆ Programmable Outputs of: +10.0V, +7.5V, +5.0V, +2.5V
- ◆ ±10mV Tolerance at +10V (MX584K)
- ◆ Low Tempco: 15ppm/°C Max. (MX584K)
- ◆ No External Component or Trims
- ◆ Short Circuit Proof
- ◆ Output Sources and Sinks Current
- ◆ 10mA Output Current

Ordering Information

| PART | TEMP. RANGE | PACKAGE* | ERROR |
|-----------|-----------------|---------------|-------|
| MX584JH | 0°C to +70°C | TO-99 Can | ±30mV |
| MX584KH | 0°C to +70°C | TO-99 Can | ±10mV |
| MX584JN | 0°C to +70°C | Plastic DIP | ±30mV |
| MX584KN | 0°C to +70°C | Plastic DIP | ±10mV |
| MX584JCSA | 0°C to +70°C | Small Outline | ±30mV |
| MX584KCSA | 0°C to +70°C | Small Outline | ±10mV |
| MX584JESA | -40°C to +85°C | Small Outline | ±30mV |
| MX584KESA | -40°C to +85°C | Small Outline | ±10mV |
| MX584JC/D | 0°C to +70°C | Dice | ±30mV |
| MX584SH | -55°C to +125°C | TO-99 Can | ±30mV |
| MX584TH | -55°C to +125°C | TO-99 Can | ±10mV |
| MX584SQ | -55°C to +125°C | CERDIP | ±30mV |
| MX584TQ | -55°C to +125°C | CERDIP | ±10mV |

*All devices—8 lead packages

Typical Operating Circuit

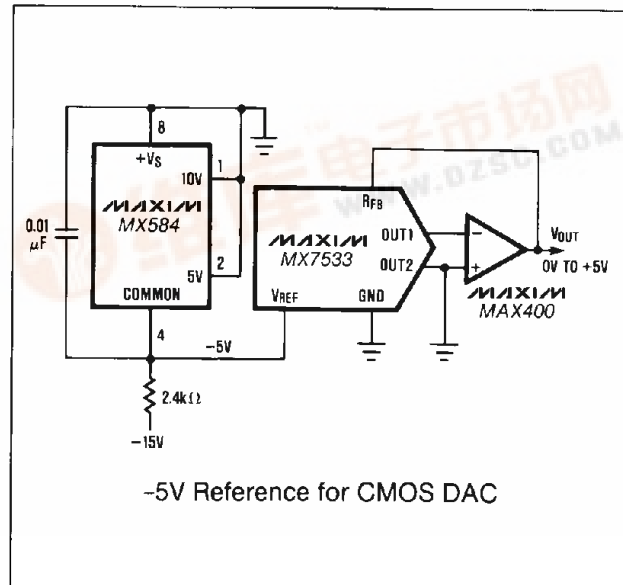

Pin Programmable Precision Voltage Reference

ABSOLUTE MAXIMUM RATINGS

| | | | |
|---------------------------------------------|-----------------|-----------------------------------------|-----------------|
| Input Voltage V_{IN} to Common | -0.3, +40V | Storage Temperature Range | -65°C to +150°C |
| Power Dissipation | | Lead Temperature (Soldering, 10sec) | +300°C |
| Metal Can (Derate 6.7mW/°C above +60°C) | 600mW | Dice Junction Temperature (T_J) | -55°C to +150°C |
| CERDIP (Derate 8mW/°C above +75°C) | 600mW | Thermal Resistance, Junction to Ambient | |
| Plastic DIP (Derate 6mW/°C above +75°C) | 450mW | Metal Can | 150°C/W |
| Small Outline (Derate 5.3mW/°C above +75°C) | 400mW | CERDIP | 125°C/W |
| Output Short-Circuit Duration (Note 1) | Indefinite | Plastic DIP | 160°C/W |
| Operating Temperature Range | | Small Outline | 170°C/W |
| Commercial (J, K) | 0°C to +70°C | | |
| Military (S, T, U) | -55°C to +125°C | | |
| Extended (J, K) | -40°C to +85°C | | |

Stresses beyond those listed under "Absolute Maximum Ratings" may cause permanent damage to the device. These are stress ratings only, and functional operation of the device at these or any other conditions beyond those indicated in the operational sections of the specifications is not implied. Exposure to absolute maximum rating conditions for extended periods may affect device reliability.

ELECTRICAL CHARACTERISTICS

($V_{IN} = +15V$, $T_A = +25°C$, unless otherwise noted.)

| PARAMETER | | SYMBOL | | MIN | TYP | MAX | UNITS |
|----------------------------------------|--------|---------------------------|---------------------------------------------------------------------------|---------------------------------------------------------------------------|-----|----------------|-------------------|
| Output Voltage Tolerance | | $I_L = 0mA$, At Pin 1 | $V_{OUT} = +10V$, MX584J/S MX584K/T | | | ±30 ±10 | mV |
| | | | $V_{OUT} = +7.5V$, MX584J/S MX584K/T | | | ±22 ±8 | |
| | | | $V_{OUT} = +5.0V$, MX584J/S MX584K/T | | | ±15 ±6 | |
| | | | $V_{OUT} = +2.5V$, MX584J/S MX584K/T | | | ±7.5 ±3.5 | |
| Output Voltage Temperature Coefficient | | | MX584J/S, All Outputs | | | 30 | ppm/°C |
| | | | MX584K, All Outputs | | | 15 | |
| | | | MX584KE, All Outputs | | | 20 | |
| | | | MX584JE, All Outputs | | | 30 | |
| | | | MX584T, +10V, +7.5V, +5V Out +2.5V Out | | | 15 20 | |
| Differential Tempco Between Outputs | | | MX584K/T | | | 3 | ppm/°C |
| | | | MX584J/S | | | 5 | |
| Quiescent Supply Current | | I_Q | $I_L = 0mA$ | | | 750 1000 | µA |
| Quiescent Current Tempco | | | | | | 1.5 | µA/°C |
| Turn-On Setting Time | | t_{ON} | $T_o \pm 1\%$ | | | 200 | µs |
| Noise | | e_{NP-P} | 0.1Hz to 10Hz | | | 50 | µV _{p-p} |
| Long-Term Stability | | | (Non-Cumulative) | | | 25 | ppm/kHrs |
| Short Circuit Current | | I_{sc} | | | | 30 | mA |
| Line Regulation | | | No Load, ($V_{OUT} + 2.5V$) < V_{IN} < +15V +15V < V_{IN} < +30V | | | 0.005 0.002 | %V |
| | | | | | | | |
| Load Regulation | | | $I_L = 0mA$ to 5mA | | | 30 | ppm/mA |
| Output Current | Source | I_L | $V_{IN} >$ $V_{OUT} + 2.5V$ | $T_A = +25°C$ T_{MIN} to T_{MAX} | | 10 5 | mA |
| | Sink | | | T_{MIN} to T_{MAX} , MX581J/K MX584S/T -55°C to +85°C, MX584S/T | | 5 0.2 5 | |

Note 1: Absolute maximum power dissipation must not be exceeded.

Pin Programmable Precision Voltage Reference

Typical Operating Characteristics

MX584

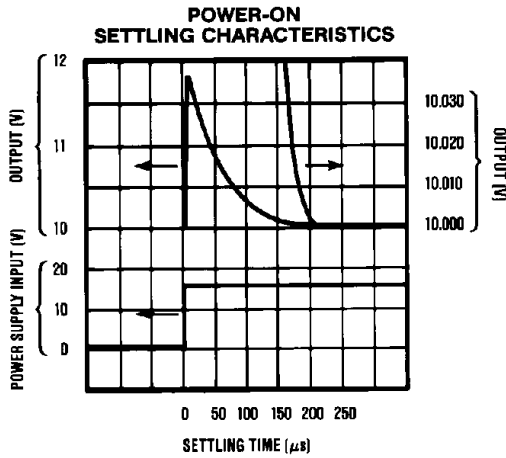
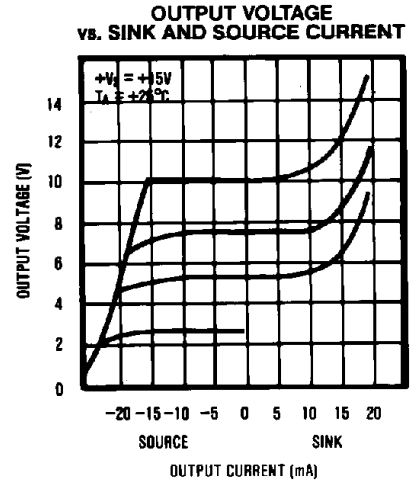
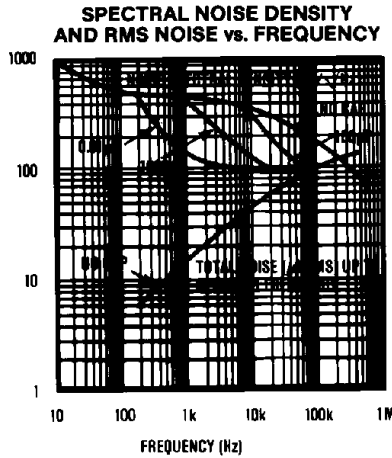
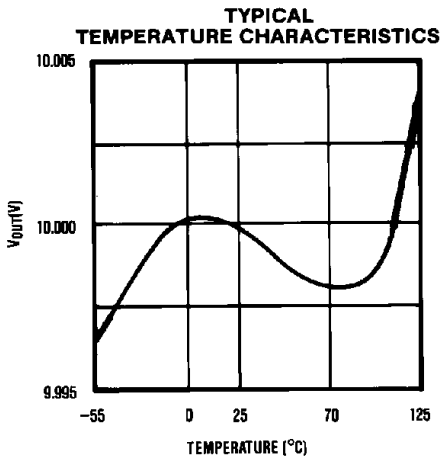

Table 1. Programming Pin Connections

| OUTPUT VOLTAGE | PROGRAMMING (OUTPUT ON PIN 1) |
|----------------|--------------------------------|
| 10V | Pins 2 and 3 are unconnected. |
| 7.5V | Connect pins 2 and 3 together. |
| 5.0V | Connect pins 2 and 1 together. |
| 2.5V | Connect pins 3 and 1 together. |

Detailed Description

As shown in Figure 1, most applications of the MX584 require no external components. Connections to $+V_S$, and COMMON (COMMON is also tied to the case in the TO-99 metal package) with all other pins unconnected result in a buffered +10.00V output at pin 1. The other pretrimmed voltages are obtained by strapping pins as shown in Table 1. If one or more external buffer amplifiers are connected to the programming pins (pin 2,3), multiple outputs can be obtained from one reference.

Other Output Voltages

The MX584 can be adjusted to a different output voltage by adding one or more resistors as in Figure 2. As the diagram shows, the reference can be thought of as a 1.215V band-gap followed by a noninverting amplifier. If R1 and R2 are used alone, the adjustment range is widest but the resolution of the trim may be too coarse, even when a multi-turn trim pot is used.

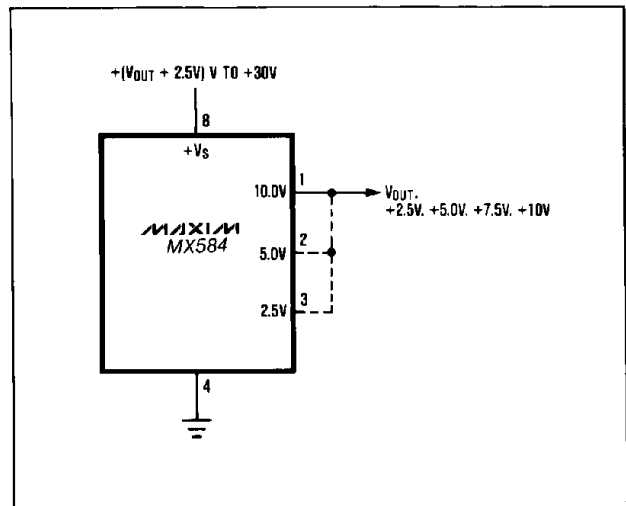

Figure 1. Basic Connection for Positive Outputs

Pin Programmable Precision Voltage Reference

When adding external resistors, output voltages well above 10V can be obtained. R2 should therefore be chosen carefully since it sets the maximum output voltage. R2's resistance should not be so low as to jeopardized other circuits if R1 is misadjusted.

The fixed output voltages can also be varied by connecting only one resistor, as in the dashed lines in Figure 2. Connecting R3 alone raises V_{OUT} while R4 alone lowers it. These resistors (or potentiometers) must have very low temperature coefficients if accuracy over temperature is to be unaffected by the adjustment.

If fine adjustment of the output is all that is required, the circuit of Figure 3 is recommended. It provides good stability and resolution for a trim range of $\pm 200mV$. If the 2.5V output is adjusted, R2 should be connected to V_{BG} , pin 6, and the trim range should be limited to $\pm 100mV$.

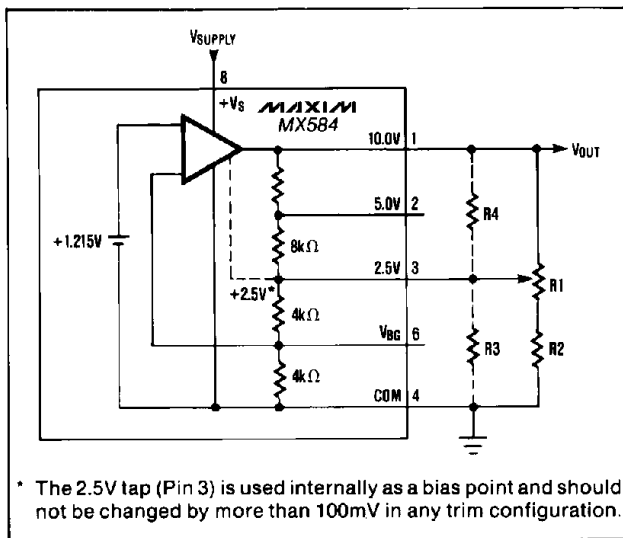

Figure 2. Variable Output Options

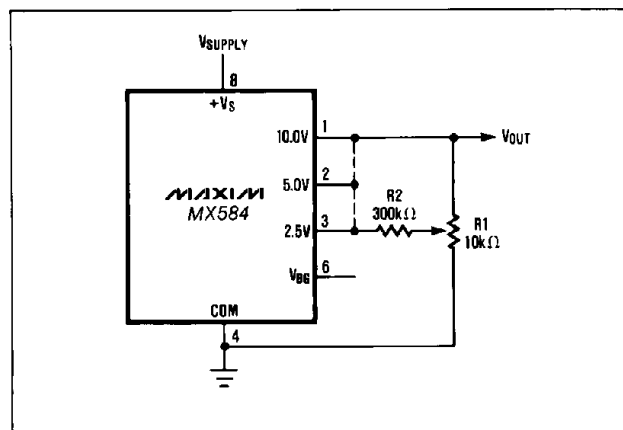

Figure 3. Fine Adjustment of Output Voltage ($\pm 200mV$)

Voltage Temperature Coefficient

The temperature characteristic of the MX584 consistently follows an "S-curve" as shown in the Typical Characteristics. A five-point 100% test guarantees compliance with $-55^{\circ}C$ to $+125^{\circ}C$ specifications and a three-point 100% test guarantees the $0^{\circ}C$ to $+70^{\circ}C$ specifications.

The tolerance specifications in the Electrical Characteristics table state the maximum deviation from the reference's initial value at $25^{\circ}C$. By adding the maximum deviation for a given device to its initial tolerance, the total possible error is determined.

Output Current

The MX584 is capable of sinking as well as sourcing current. The circuit is also protected for output shorts to either $+V_S$ or ground (COMMON). The output's voltage-versus-current characteristic is shown in the Typical Characteristics section.

Dynamic Performance

The turn-on settling performance of the MX584 is shown in the Typical Characteristics. Both coarse and fine transient response is shown. The reference typically settles to 1mV (10V output) within $180\mu s$ after power is applied.

Noise Filtering

The bandwidth of the MX584's output amplifier can be limited by connecting a capacitor between the CAP and V_{BG} pins (see Figure 4). Typical values range from $0.01\mu F$ to $0.1\mu F$. The reduction of wideband and feedthrough noise is plotted in a graph in the Typical Characteristics section.

Strobe Input

The STROBE input, pin 5, zeroes the reference output when it is pulled LOW. If no current is pulled from STROBE, operation is normal. The threshold of the input is 200mV, so an open-drain N-channel FET or open-collector transistor driven from logic is re-

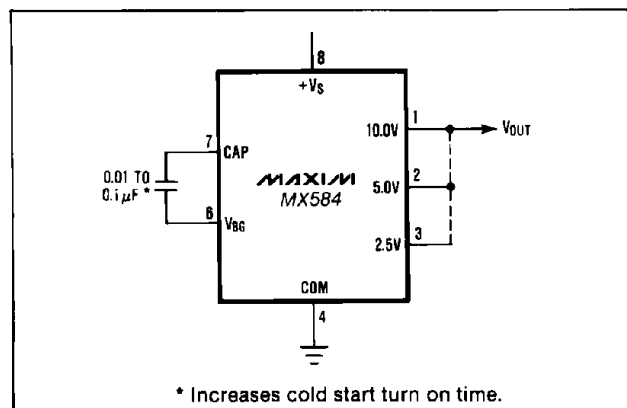

Figure 4. Additional Noise Filtering with an External Capacitor

Pin Programmable Precision Voltage Reference

commended (see Figure 5). The current sinking ability should be at least $500\mu\text{A}$ and the leakage current should be $5\mu\text{A}$ or less. While shut down, the MX584 should not be required to source or sink current unless a 0.7V residual output is acceptable. If the reference is required to sink transient current while shut down, the current flowing out of STROBE should be limited with 100Ω as shown in the dashed connection in Figure 5.

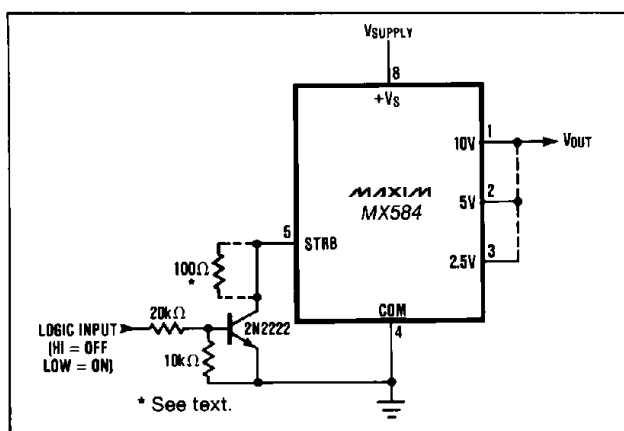

Figure 5. Use of Strobe Terminal

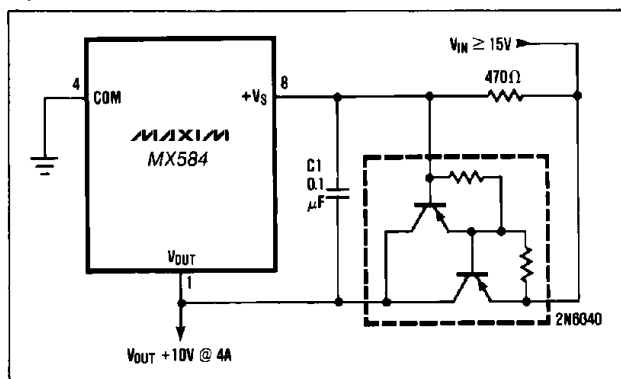

Figure 6. High Current Precision Supply

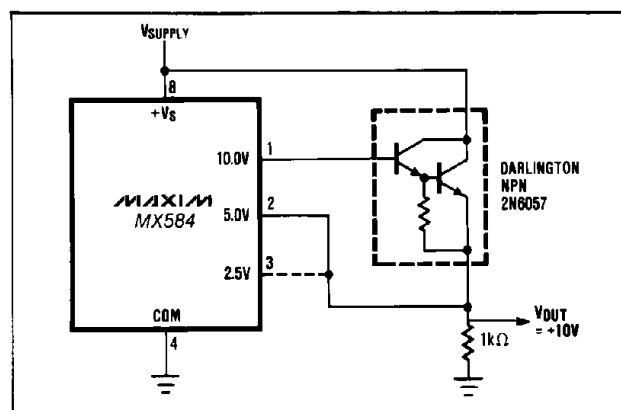

Figure 7. NPN Output Current Booster

Applications

Precision High Current Reference

A PNP power transistor, or Darlington, is easily connected to the MX584 to greatly increase its output current. The circuit in Figure 6 provides a $+10\text{V}$ output at up to 4 Amps. If the load has a significant capacitive component, C1 should be added. If the load is purely resistive, high frequency supply rejection is improved without C1. An NPN output transistor or Darlington can also be used to boost output current as shown in Figure 7.

Current Limiter

By adding a single resistor as shown in Figure 8, the MX584 is turned into a precision current limiter for applications where the driving voltage is 5V to 40V . The programmed current ranges from 0.75mA to 5mA .

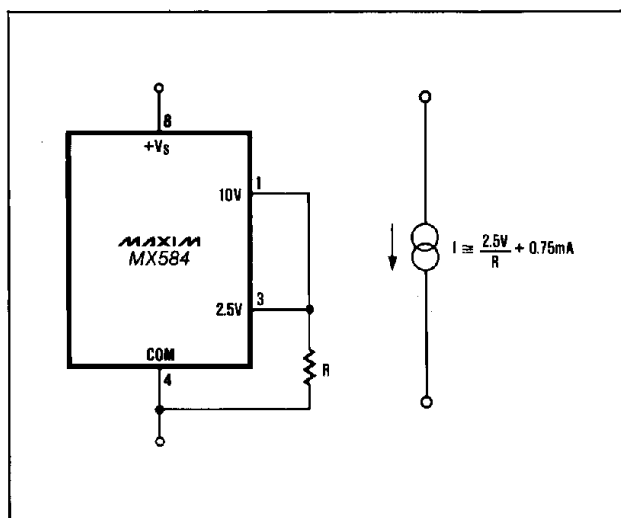

Figure 8. Precision Current Limiter

Negative 10V Reference

In applications which require a -10V , -7.5V , -5.0V , or -2.5V reference, the MX584 can be connected as a two-terminal device and biased like a zener diode. The circuit is shown in Figure 9. $+V_S$ and V_{OUT} are connected to the analog ground bus, and the MX584's COMMON pin is connected, through a resistor, to the negative supply. With 1mA flowing in the reference, the output is typically 2mV greater than what is obtained with a conventional, positive, hook-up.

When using the 2-terminal connection, the load and the bias resistor must be selected so that the current flowing in the reference is maintained between 1mA and 5mA . The operating temperature range for this connection is limited to -55° to $+85^\circ\text{C}$.

Pin Programmable Precision Voltage Reference

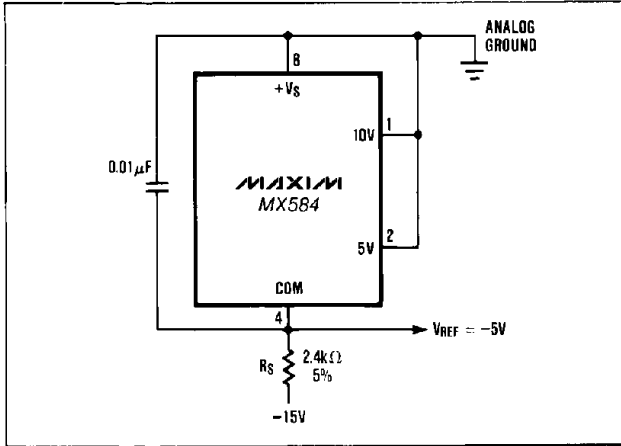

Figure 9. Two-Terminal -5 Volt Reference

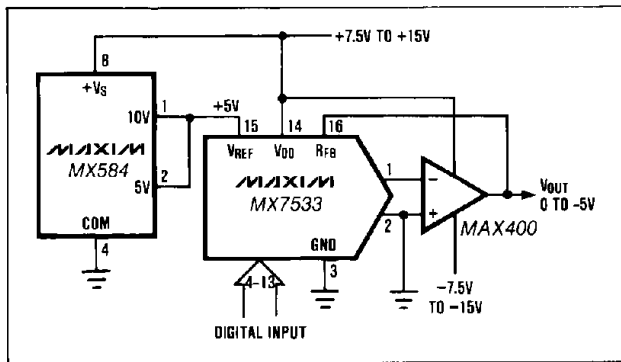

Figure 10. Low Power 10 Bit CMOS DAC Connection

Reference for DACs and ADCs

The MX584 is well suited for use with a wide variety of D-to-A converters, especially CMOS DACs. Figure 10 shows a circuit in which an MX7533 10 bit DAC outputs 0 to -5V when using a +5V reference. For a positive DAC output, the MX584 can be configured as a 2-terminal negative reference as well by using the connection of Figure 9.

In Figure 11, an MX7574 CMOS A/D converter uses an MX584, connected for -2.5V, as its reference input so that the system can operate from $\pm 5V$ power. The analog input range for the circuit is 0V to +2.5V.

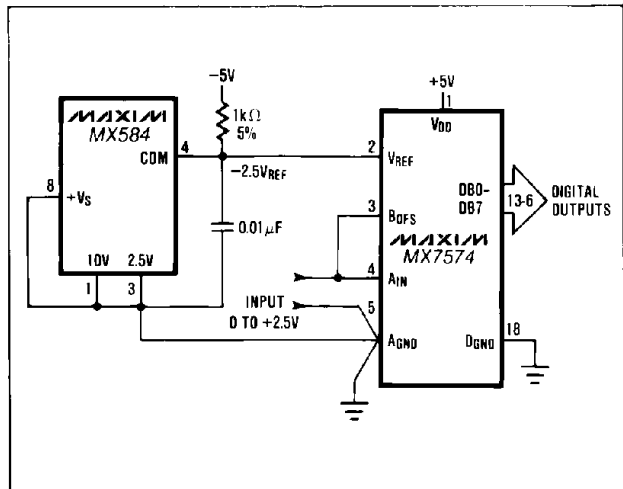
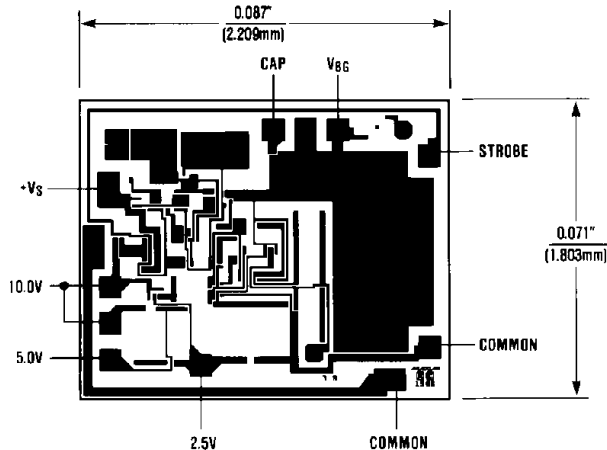

Figure 11. MX584 as Negative 2.5 Volt Reference for a CMOS ADC

Chip Topography



TRANSISTOR COUNT: 72
SUBSTRATE CONNECTED TO GND

Pin Programmable Precision Voltage Reference

Package Information

MX584

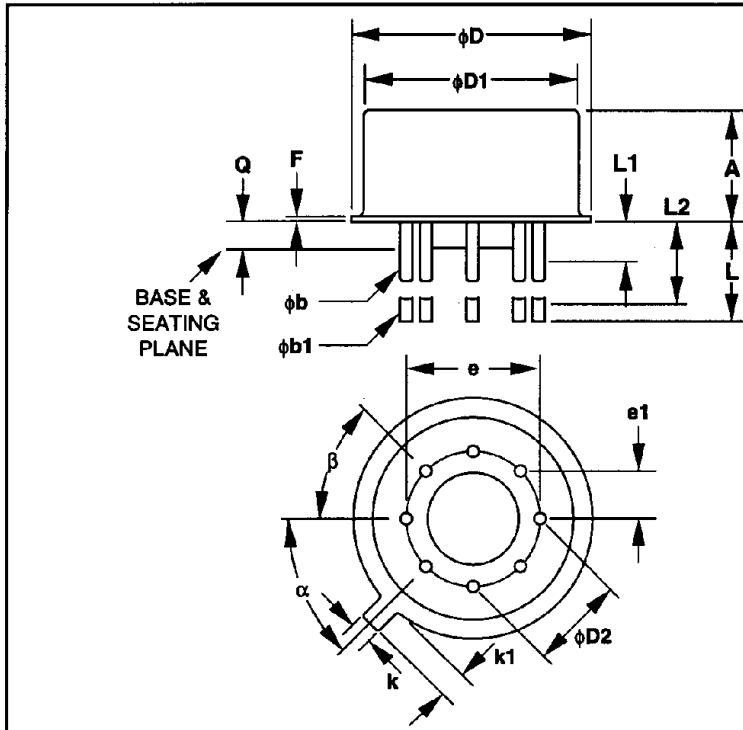

| DIM | INCHES | | MILLIMETERS | |
|-----------|-----------|-------|-------------|-------|
| | MIN | MAX | MIN | MAX |
| A | 0.165 | 0.185 | 4.19 | 4.70 |
| ϕb | 0.016 | 0.019 | 0.41 | 0.48 |
| $\phi b1$ | 0.016 | 0.021 | 0.41 | 0.53 |
| ϕD | 0.335 | 0.375 | 8.51 | 9.40 |
| $\phi D1$ | 0.305 | 0.335 | 7.75 | 8.51 |
| $\phi D2$ | 0.110 | 0.160 | 2.79 | 4.06 |
| e | 0.200 BSC | | 5.08 BSC | |
| e1 | 0.100 BSC | | 2.54 BSC | |
| F | - | 0.040 | - | 1.02 |
| k | 0.027 | 0.034 | 0.69 | 0.86 |
| k1 | 0.027 | 0.045 | 0.69 | 1.14 |
| L | 0.500 | 0.750 | 12.70 | 19.05 |
| L1 | - | 0.050 | - | 1.27 |
| L2 | 0.250 | - | 6.35 | - |
| Q | 0.010 | 0.045 | 0.25 | 1.14 |
| α | 45° BSC | | 45° BSC | |
| β | 45° BSC | | 45° BSC | |

21-0022A

8-PIN TO-99 METAL CAN PACKAGE

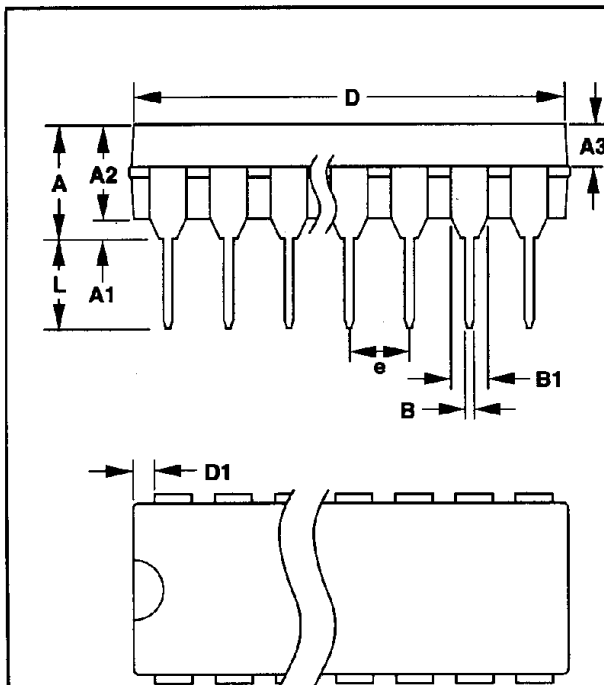

Plastic DIP PLASTIC DUAL-IN-LINE PACKAGE (0.300 in.)

| DIM | INCHES | | MILLIMETERS | |
|-----|--------|-------|-------------|-------|
| | MIN | MAX | MIN | MAX |
| A | - | 0.200 | - | 5.08 |
| A1 | 0.015 | - | 0.38 | - |
| A2 | 0.125 | 0.175 | 3.18 | 4.45 |
| A3 | 0.055 | 0.080 | 1.40 | 2.03 |
| B | 0.016 | 0.022 | 0.41 | 0.56 |
| B1 | 0.045 | 0.065 | 1.14 | 1.65 |
| C | 0.008 | 0.012 | 0.20 | 0.30 |
| D1 | 0.005 | 0.080 | 0.13 | 2.03 |
| E | 0.300 | 0.325 | 7.62 | 8.26 |
| E1 | 0.240 | 0.310 | 6.10 | 7.87 |
| e | 0.100 | - | 2.54 | - |
| eA | 0.300 | - | 7.62 | - |
| eB | - | 0.400 | - | 10.16 |
| L | 0.115 | 0.150 | 2.92 | 3.81 |

| PKG. | DIM | PINS | INCHES | | MILLIMETERS | |
|------|-----|------|--------|-------|-------------|-------|
| | | | MIN | MAX | MIN | MAX |
| P | D | 8 | 0.348 | 0.390 | 8.84 | 9.91 |
| P | D | 14 | 0.735 | 0.765 | 18.67 | 19.43 |
| P | D | 16 | 0.745 | 0.765 | 18.92 | 19.43 |
| P | D | 18 | 0.885 | 0.915 | 22.48 | 23.24 |
| P | D | 20 | 1.015 | 1.045 | 25.78 | 26.54 |
| N | D | 24 | 1.14 | 1.265 | 28.96 | 32.13 |

21-0043A

Pin Programmable Precision Voltage Reference

Package Information (continued)

**Narrow SO
SMALL-OUTLINE
PACKAGE
(0.150 in.)**

| DIM | INCHES | | MILLIMETERS | |
|-----|--------|-------|-------------|------|
| | MIN | MAX | MIN | MAX |
| A | 0.053 | 0.069 | 1.35 | 1.75 |
| A1 | 0.004 | 0.010 | 0.10 | 0.25 |
| B | 0.014 | 0.019 | 0.35 | 0.49 |
| C | 0.007 | 0.010 | 0.19 | 0.25 |
| E | 0.150 | 0.157 | 3.80 | 4.00 |
| e | 0.050 | | 1.27 | |
| H | 0.228 | 0.244 | 5.80 | 6.20 |
| L | 0.016 | 0.050 | 0.40 | 1.27 |

| DIM | PINS | INCHES | | MILLIMETERS | |
|-----|------|--------|-------|-------------|-------|
| | | MIN | MAX | MIN | MAX |
| D | 8 | 0.189 | 0.197 | 4.80 | 5.00 |
| D | 14 | 0.337 | 0.344 | 8.55 | 8.75 |
| D | 16 | 0.386 | 0.394 | 9.80 | 10.00 |

21-0041A

**CERDIP
CERAMIC DUAL-IN-LINE
PACKAGE
(0.300 in.)**

| DIM | INCHES | | MILLIMETERS | |
|-----|--------|-------|-------------|------|
| | MIN | MAX | MIN | MAX |
| A | - | 0.200 | - | 5.08 |
| B | 0.014 | 0.023 | 0.36 | 0.58 |
| B1 | 0.038 | 0.065 | 0.97 | 1.65 |
| C | 0.008 | 0.015 | 0.20 | 0.38 |
| E | 0.220 | 0.310 | 5.59 | 7.87 |
| E1 | 0.290 | 0.320 | 7.37 | 8.13 |
| e | 0.100 | | 2.54 | |
| L | 0.125 | 0.200 | 3.18 | 5.08 |
| L1 | 0.150 | - | 3.81 | - |
| Q | 0.015 | 0.070 | 0.38 | 1.78 |
| S | - | 0.098 | - | 2.49 |
| S1 | 0.005 | - | 0.13 | - |

| DIM | PINS | INCHES | | MILLIMETERS | |
|-----|------|--------|-------|-------------|-------|
| | | MIN | MAX | MIN | MAX |
| D | 8 | - | 0.405 | - | 10.29 |
| D | 14 | - | 0.785 | - | 19.94 |
| D | 16 | - | 0.840 | - | 21.34 |
| D | 18 | - | 0.960 | - | 24.38 |
| D | 20 | - | 1.060 | - | 26.92 |
| D | 24 | - | 1.280 | - | 32.51 |

21-0045A

Maxim cannot assume responsibility for use of any circuitry other than circuitry entirely embodied in a Maxim product. No circuit patent licenses are implied. Maxim reserves the right to change the circuitry and specifications without notice at any time.