

# MX•COM, INC. MIXed Signal ICs

DATA BULLETIN

## MX663 Call Progress Decoder

### PRELIMINARY INFORMATION

#### Features

- **Worldwide Call Progress Tone Decoding:**
  - Single and Dual Tones
  - Fax and Modem
  - Answer/Oriinate Tones
  - SIT (Special Information Tones)
  - Fast 'US Busy' Tone Detector
- **Adjustable Detection Threshold**
- **Voice Detector**
- **Low Power 3.3V/5.0V Operation**

#### Applications

- **Call Progress Monitoring**
- **Automatic Call Placement**
- **Machine Dialing**
- **Fax Tone Detection for Line Switching**

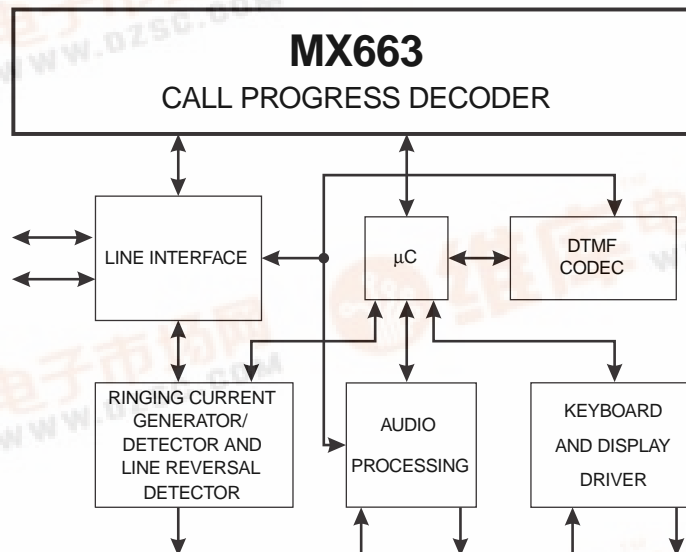

The MX663 decodes the standard audible tone signals provided by telecom systems worldwide to indicate Dial, Ringing, Busy, Unobtainable and other stages of a call attempt. It provides the key features needed for intelligent, full-function, call progress monitoring by applications involving machine dialing or automatic call placement. The MX663 also incorporates the following features:

- Single and dual tone decoding for better cross-system Call Progress monitoring.
- "US Busy" tone detector, saving time needed for "cadence verification" under Busy and Unobtainable conditions. This incorporates a separate 620Hz detector for improved response.
- A detector to indicate speech and non-call progress signals; this reduces voice falsing of call progress tones and adds Voice-Answer detection as a "connected" prompt.
- A fax and modem tone decoder.
- A separate, adjustable threshold, signal-level detector which reduces noise falsing.

The MX663 uses digital signal processing techniques to provide these advantages. It is a low cost, low power product with superior performance. The MX663 may be used with a 3.0 to 5.5 volt supply and is available in the following packages: 16-pin SOIC (MX663DW) or 16-pin PDIP (MX663P).



# CONTENTS

Section	Page
<b>1. Block Diagram</b> .....	<b>3</b>
<b>2. Signal List</b> .....	<b>4</b>
<b>3. External Components</b> .....	<b>5</b>
<b>4. General Description</b> .....	<b>6</b>
4.1 Overall Function Description .....	6
4.2 Glossary .....	6
4.3 Block Diagram Description (Reference Figure 1) .....	6
4.3.1 SIGIN.....	6
4.3.2 Call Progress Detector: Signal Analyzer .....	7
4.3.3 620Hz Detector .....	7
4.3.4 Control and Output Logic .....	7
4.3.5 Level Detector and OPAMP .....	7
4.3.6 Xtal/Clock Oscillator .....	7
4.3.7 Decode Output Truth Table.....	8
<b>5. Application</b> .....	<b>9</b>
5.1 General.....	9
5.2 Signal Category Reference .....	9
5.3 Typical Response .....	10
<b>6. Performance Specification</b> .....	<b>11</b>
6.1 Electrical Performance .....	11
6.1.1 Absolute Maximum Ratings.....	11
6.1.2 Operating Limits .....	11
6.1.3 Operating Characteristics.....	12
6.2 Timing.....	13
6.3 Packaging.....	16

MX COM, Inc. reserves the right to change specifications at any time and without notice.

# 1. Block Diagram

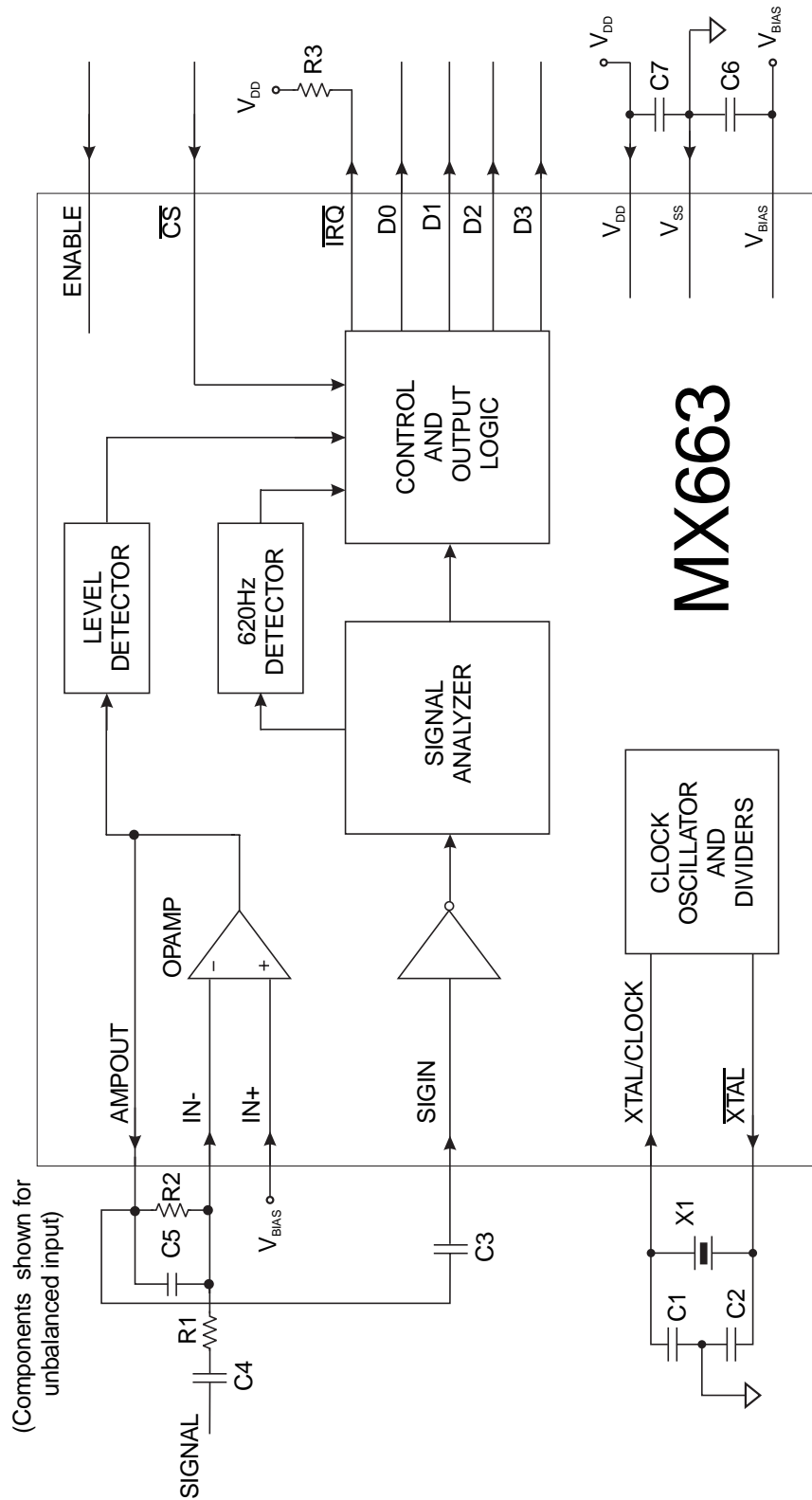

Figure 1: Block Diagram

## 2. Signal List

Pin No.	Signal	Type	Description
1	$\overline{\text{XTAL}}$	output	Inverted output of the on-chip oscillator.
2	XTAL/CLOCK	input	Input to the on-chip oscillator, for external Xtal circuit or clock.
3 4 5 6	D3 D2 D1 D0	output	D3, D2, D1 and D0 is a 4-bit parallel data word output to the $\mu\text{C}$ . The transmission of data is under the control of the $\overline{\text{CS}}$ input. These 3-state outputs are held at high impedance when $\overline{\text{CS}}$ is at "1". See Figure 8  If $\overline{\text{CS}}$ is permanently at "0", D3, D2, D1 and D0 are permanently active. See Figure 4 and Figure 7.
7	$\overline{\text{CS}}$	input	The chip select pin activates the Data Bus "D0: 3" when held low. A $\mu\text{C}$ can provide this input to allow the MX663 to reside on a shared Data Bus. Data transfer sequences are initiated, completed or aborted by the $\overline{\text{CS}}$ signal. See Figure 8
8	$\overline{\text{IRQ}}$	output	This output indicates an interrupt condition to the $\mu\text{C}$ by going to a logic "0". This is a "wire-ORable" output, enabling the connection of up to 8 peripherals to 1 interrupt port on the $\mu\text{C}$ . This pin has a low impedance pulldown to logic "0" when active and a high-impedance when inactive. An external pullup resistor is required.  If $\overline{\text{CS}}$ is permanently at "0", the interrupt condition is a logic "0" pulse. See Figure 4 and Figure 7.
9	ENABLE	input	A low level input selects the powersave mode, all circuits are reset and disabled. D0 - D3 outputs become high impedance. A high level input enables all circuits.
10	$V_{\text{SS}}$	Power	Negative supply (ground).
11	SIGIN	input	Signal input. The signal to this pin should be ac coupled. The dc bias of this pin is set internally.
12	$V_{\text{BIAS}}$	output	Internally generated bias voltage, held at $V_{\text{DD}}/2$ when the device is not in powersave mode, it should be bypassed to $V_{\text{SS}}$ by a capacitor mounted close to the device pins. In powersave mode this pin is pulled towards $V_{\text{SS}}$ .
13	IN+	input	Non-inverting input to the on-chip amplifier.
14	IN-	input	Inverting input to the on-chip amplifier.
15	AMPOUT	output	Output of the on-chip amplifier, this is internally connected to the input of the Level Detector.
16	$V_{\text{DD}}$	Power	The positive supply rail. Levels and voltages are dependent upon this supply. This pin should be bypassed to $V_{\text{SS}}$ by a capacitor.

**Table 1: Signal List**

### 3. External Components

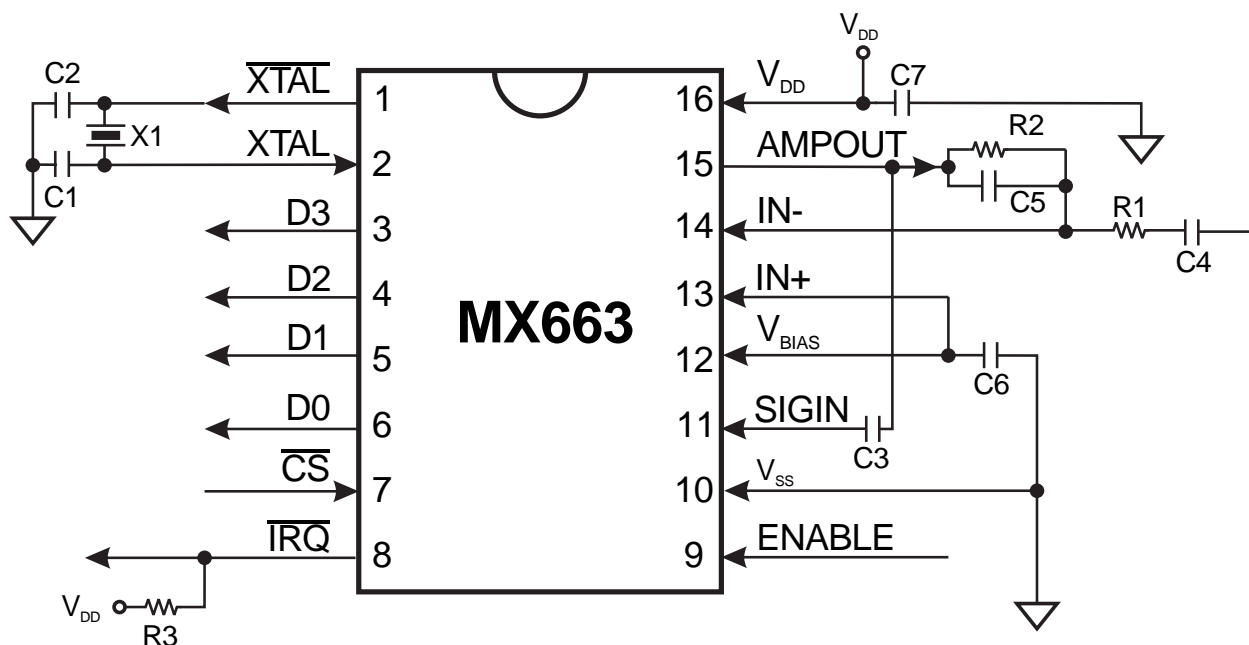

Figure 2: Recommended External Components

R1	Note 3	100k $\Omega$	$\pm 10\%$
R2	Note 3	510k $\Omega$	$\pm 10\%$
R3		20k $\Omega$	$\pm 10\%$
C1		33pF	$\pm 20\%$
C2		33pF	$\pm 20\%$
C3		0.1 $\mu$ F	$\pm 20\%$

C4	Note 3	0.1 $\mu$ F	$\pm 20\%$
C5	Note 3	100pF	$\pm 20\%$
C6		1.0 $\mu$ F	$\pm 20\%$
C7		1 $\mu$ F	$\pm 20\%$
X1	Note 1, 2	3.579545MHz	$\pm 100$ ppm

Table 2: Recommended External Components

#### Notes

1. A standard Color Burst Crystal Frequency is recommended.
2. For best results, a crystal oscillator design should drive the clock inverter input with signal levels of at least 40% of  $V_{DD}$ , peak to peak. Tuning fork crystals generally cannot meet this requirement. To obtain crystal oscillator design assistance, consult your crystal manufacturer.
3. Reference section 4.3.5.

## 4. General Description

### 4.1 Overall Function Description

The MX663 consists of a Call Progress Tone Detector, a 620Hz Detector and a Level Detector.

The MX663 Call Progress Tone Detector uses different tone detection methods from those commonly found with other products.

Many traditional devices use a bandpass filter followed by an energy detector. The filter is usually designed to pass input signals with a frequency between about 300Hz and 700Hz, and the amplitudes of signals in this range are then checked against a level threshold. Any signal of acceptable level in this frequency band is classed as a Call Progress tone, including signals due to speech and noise. False outputs caused by speech are a common feature with these products, and background noise may lead to a stuck "detect" output.

The MX663, by contrast, uses a stochastic signal processing technique based on analysis in both the frequency and time domain, with signal amplitude forming a small part in the decision process. This analysis includes checks on whether the signal has a "profile" which matches international standards for Call Progress tones, or a profile more likely to match that of speech, noise or other non-call-progress signals. It also adds checks on whether tones which include frequencies corresponding with the "US Busy" signals, Special Information Tones and Fax/Modem Tones have been detected.

### 4.2 Glossary

**Call Progress Tones:** The single and dual frequency tones in the range 350Hz to 620Hz specified widely for call progress signaling.

**Call Progress Band:** The nominal range 340Hz to 700Hz within which the MX663 will detect Call Progress tones. The detection algorithm requires that the tones have the characteristics typical of Call Progress Tones.

**620Hz Detection:** The nominal range 590Hz to 650Hz. Single tones in this range, or dual tones having a material frequency component within this range (e.g. 480 + 620Hz) will be detected.

**Non Call Progress Signal:** A signal falling within the nominal range (a) 190Hz to 895Hz, but NOT within the Call Progress Band, or (b) within the nominal range 190Hz to 895Hz, but NOT meeting the DETECTION REQUIREMENTS when the signal falls in the Call Progress Band.

Subject to the duration and other characteristics of such signals, the MX663 will usually interpret these as a Non Call Progress Signal (e.g. speech or other signal activity).

**Special Information Tone:** The nominal frequencies 950Hz or 1400Hz or 1800Hz.

**Fax/Modem Low Tone:** The nominal frequency 1250Hz.

**Fax/Modem High Tone:** The nominal frequency 2150Hz.

**Minimum Input Signal:** The minimum signal level for the specified tone decoding performance. The lower level at which absence of an input signal will be registered is not specified. However, a separate signal level detector makes amplitude information available.

**No Signal:** A signal falling outside the nominal range 180Hz to 2280Hz or the absence of an input signal. Either will be detected as a No Signal condition.

**Nominal:** Subject to dynamic tolerances within the signal analysis process. Absolute values are not material or adverse to performance.

### 4.3 Block Diagram Description (Reference Figure 1)

#### 4.3.1 SIGIN

The input signal is amplified by a self-biased inverting amplifier. The dc bias of this input is internally set at. Accordingly, the input signal should be capacitively coupled to SIGIN.

### 4.3.2 Call Progress Detector: Signal Analyzer

The analyzer samples the call progress signal at 9.322kHz. An external Anti-Alias Filter can be configured using the on-chip opamp. The frequency range, quality and consistency of the input signal is analyzed by this functional block. To be classified as a call progress signal the input signal frequencies should lie between 340Hz and 700Hz, the signal to noise ratio must be 16dB or greater and the signal must be consistent over a period of at least 145ms. These decode criteria are continuously monitored and the assessment is updated every 7ms. See section 4.3.5.

Because the analyzer time samples the input signal (SIGIN), signals above the operating band (2300Hz) can alias, appear inband, and therefore be detected. Accordingly, applying signals above (2300Hz) should be avoided. Such signals may be inadvertently generated by other sources such as digital clocks, switching power supply, crosstalk, etc.

### 4.3.3 620Hz Detector

The detector is designed to aid detection of "US Busy" tone. The bandwidth of the 620Hz Detector is 60Hz and the signal must be consistent over a period of at least 145ms for detection to occur. This assessment is updated every 55ms.

### 4.3.4 Control and Output Logic

This block categorizes the nature of the signal into various decoded output states and controls the four outputs. See the Truth Table in section 4.3.7.

### 4.3.5 Level Detector and OPAMP

The OPAMP is configured as an amplifier with external components R1, R2, C4 and C5. The level detector operates by measuring the level of the amplified input signal and comparing it with a preset threshold which is defined inside the MX663 as shown in the gain calculations below.

The detector output goes to the Control and Output Logic block. The data output is gated with the level detector's output. The data output is valid only if the level detector output is true. The level detector output can be forced true by connecting IN+ to V<sub>BIAS</sub> and IN- to V<sub>SS</sub> through a 100kΩ resistor. An interrupt is produced if the output data changes state.

#### Gain Calculations:

1. Set gain so an input signal level is amplified above the threshold level of 250mV<sub>P-P</sub>.

$$\text{Gain} > \frac{250\text{mV}_{P-P}}{V_{IN}}$$

where V<sub>IN</sub> is the input signal level at C4 in mV<sub>P-P</sub>.

In simplified form to assist with component value selection:

1. DC Gain = -R2/R1
2. C5 and R2 form a low-pass filter to attenuate out of band signals applied to SIGIN. The low pass filter's band edge is determined by the following: The recommended R2 and C5's component values are selected so that  
f(-3dB) = 3120Hz .

$$f(-3\text{dB}) = \frac{1}{2 \cdot \pi \cdot R2 \cdot C5}$$

3. C4 is a DC blocking capacitor, large enough to avoid affecting the AC gain in the frequency band of interest.
4. The following formula defines the ac gain as a function of frequency, R1, R2 and C5 component values.  
AC gain, Av(f)

$$|Av(f)| = \frac{R1}{R2 \cdot \sqrt{1 + (2 \cdot \pi \cdot f \cdot R2 \cdot C5)^2}}$$

### 4.3.6 Xtal/Clock Oscillator

If the on-chip Xtal oscillator is to be used, then external components X1, C1 and C2 are required. If an external clock source is to be used, then it should be connected to the XTAL/CLOCK input pin and the XTAL pin should be left unconnected.

## 4.3.7 Decode Output Truth Table

D3	D2	D1	D0	Conditions
0	0	0	0	No Signal
0	0	0	1	Call Progress Dual Tones: Will detect 350+440, 400+450, 440+480 Hz tones
0	0	1	0	Non Call Progress Signal, e.g. Voice Activity
0	0	1	1	Call Progress Dual Tone including 620Hz Detection: Will detect 480+620 Hz tones
0	1	0	0	Special Information Tone: Will detect 950, 1400 and 1800 Hz tones
0	1	0	1	Call Progress Single Tone: Will detect 400, 425, 440 and 450 Hz tones
0	1	1	0	Will detect a single tone lying outside the Call Progress Band and within the Non Call Progress signal range
0	1	1	1	Call Progress Single Tone including 620Hz Detection: Will detect 600 and 620 Hz tones
1	0	0	0	Fax/modem High Tone: Will detect 2100 and 2200 Hz tones
1	0	0	1	Reserved for future use
1	0	1	0	Reserved for future use
1	0	1	1	Reserved for future use
1	1	0	0	Fax/modem Low Tone: Will detect 1200 and 1300 Hz tones
1	1	0	1	Reserved for future use
1	1	1	0	Reserved for future use
1	1	1	1	Reserved for future use

Table 3: Decode Truth Table

## 5. Application

### 5.1 General

Apply a reset after power-up by taking the ENABLE pin low. This places the device in a powersave mode and resets the internal circuits. It also places the data word output (D0-D3) in a high impedance state, regardless of the level on the  $\overline{CS}$  pin.

From this mode the device can be returned to normal operation without any additional settling time, when using the component values recommended in Figure 2. The tone response times remain the same and are given in section 6.1.

An interrupt is produced when the decode state is changed. This interrupt is reset by  $\overline{CS}$  going to logic "0". When  $\overline{CS}$  is permanently at "0", the interrupt condition is a 5  $\mu$ s logic "0" pulse on the  $\overline{IRQ}$  pin. When  $\overline{CS}$  is set to logic "1", the data word output (D0-D3) goes into a high impedance state.

### 5.2 Signal Category Reference

Signal Category	Sub-Category	Output Code D <sub>3:0</sub>
No Signal		0 0 0 0
Voice and Non-Call Progress Signal	Not Single Tone	0 X 1 0
	Single Tone outside of CP band	0 0 1 0
		0 1 1 0
Call Progress Signal	Dual Tone without 620Hz	0 X X 1
	Dual Tone with 620Hz	0 0 0 1
	Single Tone not 620Hz	0 0 1 1
	Single Tone 620Hz	0 1 0 1
		0 1 1 1
Special Information Tone (SIT Tone)	N/A	0 1 0 0
FAX/MODEM	Low	1 1 0 0
	High	1 0 0 0
Unused Codes	Reserved for future use	1 0 0 1, 1 0 1 0, 1 0 1 1, 1 1 0 1, 1 1 1 0, 1 1 1 1

**Table 4: Signal Category**

### 5.3 Typical Response

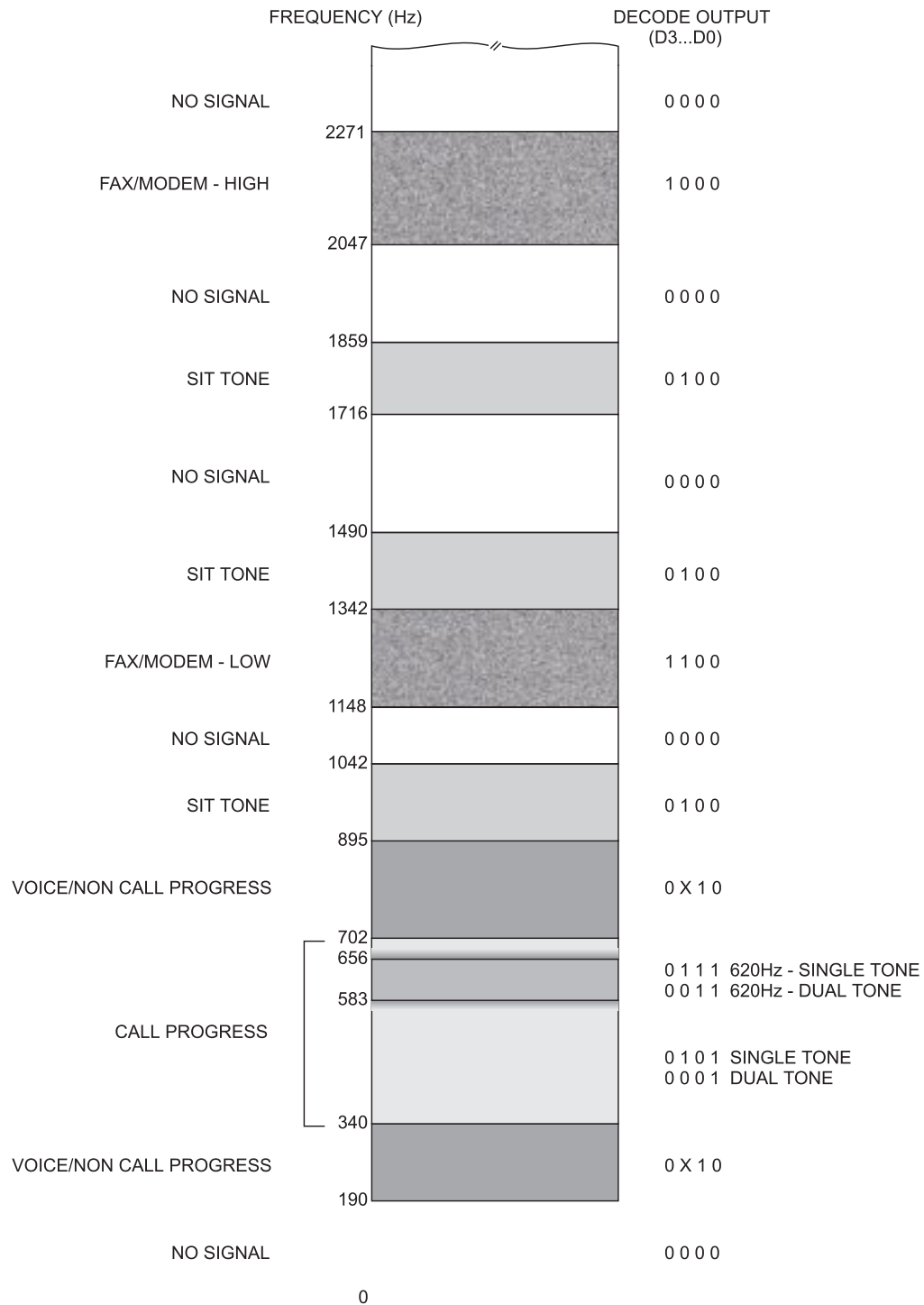

Figure 3: Typical Response Chart

## 6. Performance Specification

### 6.1 Electrical Performance

#### 6.1.1 Absolute Maximum Ratings

Exceeding these maximum ratings can result in damage to the device.

General	Min.	Max.	Units
Supply ( $V_{DD} - V_{SS}$ )	-0.3	7.0	V
Voltage on any pin to $V_{SS}$	-0.3	$V_{DD} + 0.3$	V
Current			
$V_{DD}$	-30	30	mA
$V_{SS}$	-30	30	mA
Any other pin	-20	20	mA
<b>P / DW Packages</b>			
Total Allowable Power Dissipation at $T_{AMB} = 25^{\circ}\text{C}$		800	mW
Derating above $25^{\circ}\text{C}$		13	mW/ $^{\circ}\text{C}$ above $25^{\circ}\text{C}$
Storage Temperature	-55	125	$^{\circ}\text{C}$
Operating Temperature	-40	85	$^{\circ}\text{C}$

#### 6.1.2 Operating Limits

Correct operation of the device outside these limits is not implied.

	Notes	Min.	Max.	Units
Supply ( $V_{DD} - V_{SS}$ )		3.0	5.5	V
Operating Temperature		-40	85	$^{\circ}\text{C}$
Xtal Frequency		3.57	3.59	MHz

### 6.1.3 Operating Characteristics

For the following conditions unless otherwise specified:

Xtal Frequency = 3.579545MHz (Color Burst Crystal)

$V_{DD} = 3.3V$  to  $5.0V$ ,  $T_{AMB} = 25^{\circ}C$ .

0dB = 775 mV<sub>RMS</sub>, S/N = 20dB, Noise Bandwidth = 5kHz Band Limited Gaussian

	Notes	Min.	Typ.	Max.	Units	
<b>DC Parameters</b>						
<b>I<sub>DD</sub></b>						
all powersaved	1, 2		30		μA	
$V_{DD} = 3.3V$	1		0.5	1	mA	
$V_{DD} = 5.0V$	1		1.0	2	mA	
<b>Logic Interface</b>						
Input Logic '1'		70%			$V_{DD}$	
Input Logic '0'				30%	$V_{DD}$	
Input Leakage Current		Logic '1' or '0'		-1.0	1.0	μA
Input Capacitance				7.5	pF	
Output Logic '1'		$I_{OH} = 120\mu A$	90%		$V_{DD}$	
Output Logic '0'		$I_{OL} = 360\mu A$		10%	$V_{DD}$	
'Off' State Leakage Current	3			10.0	μA	
<b>AC Parameters</b>						
<b>SIGIN Pin</b>						
Input Impedance	4		0.35		MΩ	
Minimum Input Signal Level			-40.0		dB	
Input Signal Dynamic Range		40.0			dB	
<b>Level Detector</b>						
Signal Level Detection Threshold	5	measured at AMPOUT pin	-19.0		dB	
<b>OPAMP</b>						
Input Impedance	6	10.0			MΩ	
Voltage gain			500		V/V	
<b>Xtal/Clock Input</b>						
Pulse Width	7	'High' or 'Low'	40.0		ns	
Input Impedance		at 100Hz	10.0		MΩ	
Gain		input = 1 mV <sub>RMS</sub> at 1kHz	20.0		dB	

#### Notes:

1. Not including any current drawn from the device pins by external circuitry.
2. Enable input at  $V_{SS}$ ,  $\overline{CS}$  input at  $V_{DD}$ .
3.  $\overline{IRQ}$  pin, D0 to D3 pins.
4. Small signal impedance over the frequency range 100Hz to 2300Hz and at 5.0V.
5. Input signal level is multiplied by the voltage gain (-R2/R1). The overall signal at AMPOUT should be larger than 250mV<sub>P-P</sub>, for  $V_{DD} = 5.0V$ . This threshold is proportional to  $V_{DD}$ .
6. Open loop, small signal low frequency measurements.
7. Timing for an external input to the XTAL/CLOCK pin.

## 6.2 Timing

For the following conditions unless otherwise specified:  
 Xtal Frequency = 3.579545MHz, V<sub>DD</sub> = 3.3V to 5.0V, T<sub>AMB</sub> = 25°C.

	Parameter	Notes	Min.	Typ.	Max.	Units
t <sub>RP</sub>	Call Progress Tone Response Time	1			145	ms
t <sub>DRP</sub>	Call Progress Tone De-response Time	1			145	ms
t <sub>NRP</sub>	Non Call Progress Signal Response Time		145			ms
t <sub>NDRP</sub>	Non Call Progress Signal De-response Time			80		ms
t <sub>I</sub>	Burst Length Ignored	1			70	ms
t <sub>L</sub>	Burst Length Detected	1	145			ms
t <sub>GI</sub>	Call Progress Tone Gap Length Ignored	1, 2, 3,			20	ms
t <sub>GD</sub>	Call Progress Tone Gap Length Detected	1, 2	40			ms
t <sub>NG</sub>	Non Call Progress Signal Gap Length Ignored	4		80		ms
t <sub>DI</sub>	Data available to Interrupt pulse				430	µs
t <sub>DE</sub>	"CS -Low " to Data Valid				0.2	µs
t <sub>HIZ</sub>	"CS -High" to Output Tri-state				1.0	µs
t <sub>IR</sub>	Interrupt Reset Time				0.2	µs
t <sub>IP</sub>	Interrupt Low Pulse		4.0	5.0	6.0	µs

**Notes:**

1. Timing also applies to Special Information Tones and Fax/modem Tones.
2. Only applies to burst of the same frequency.
3. For Special Information Tones and Fax/Modem tones, t<sub>GI</sub> is 15ms maximum.
4. If the gap > 90ms, a NO Signal state will be detected.

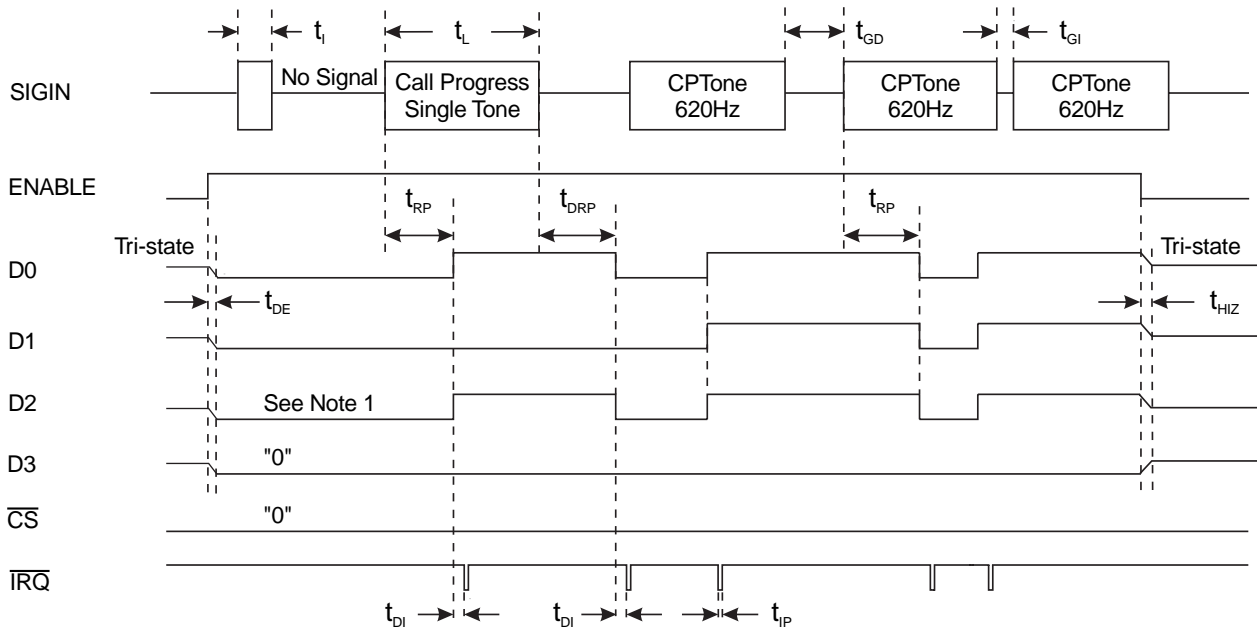

**Note**

1. D2 is '1' only when the Call Progress signal, or a Non Call Progress signal, is a single frequency tone.

**Figure 4: Timing Diagram: Call Progress Tone(s)**

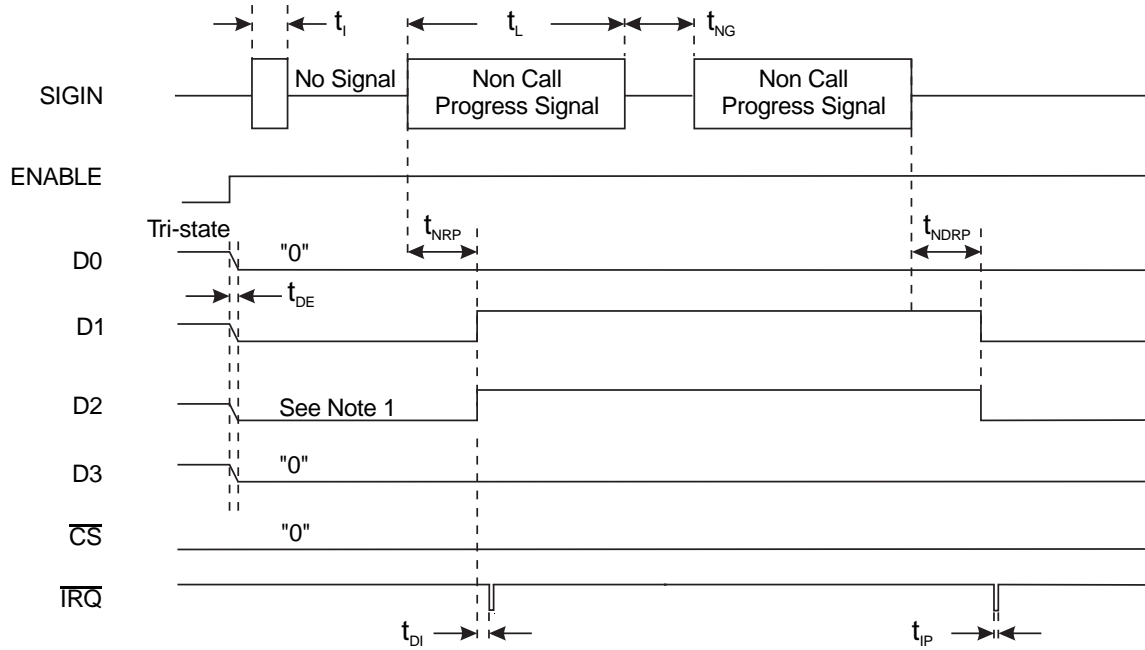

**Note:**

1. D2 is '1' only when the Call Progress signal, or a Non Call Progress signal, is a single frequency tone.

**Figure 5: Timing Diagram: Non Call Progress Signal**

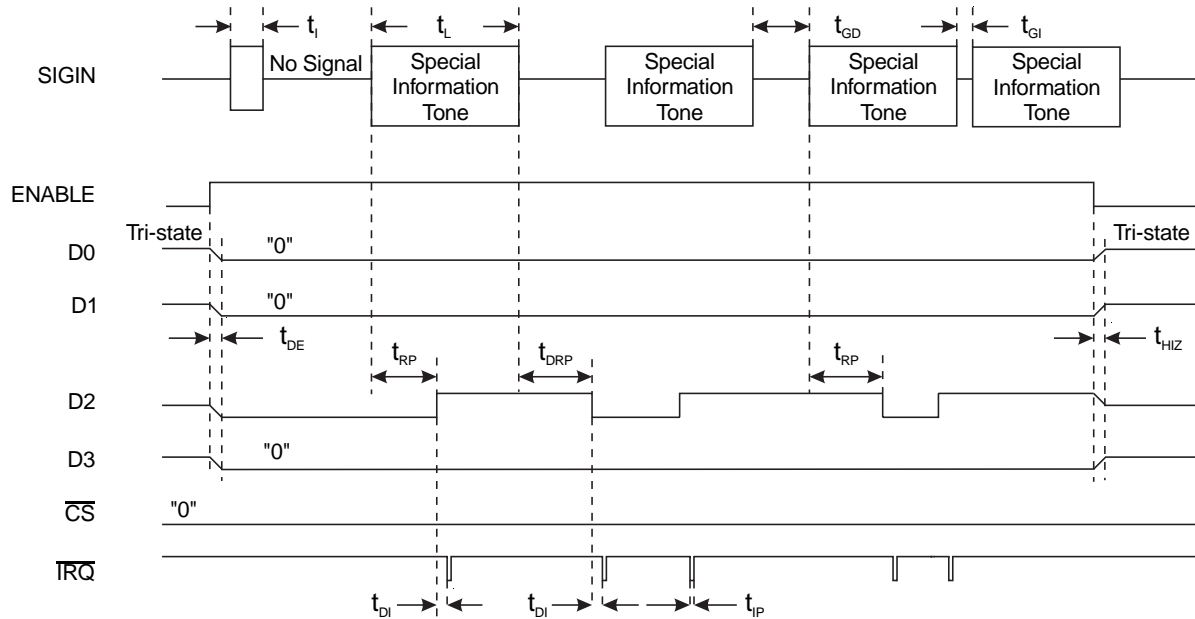

**Figure 6: Timing Diagram: Special Information Tones**

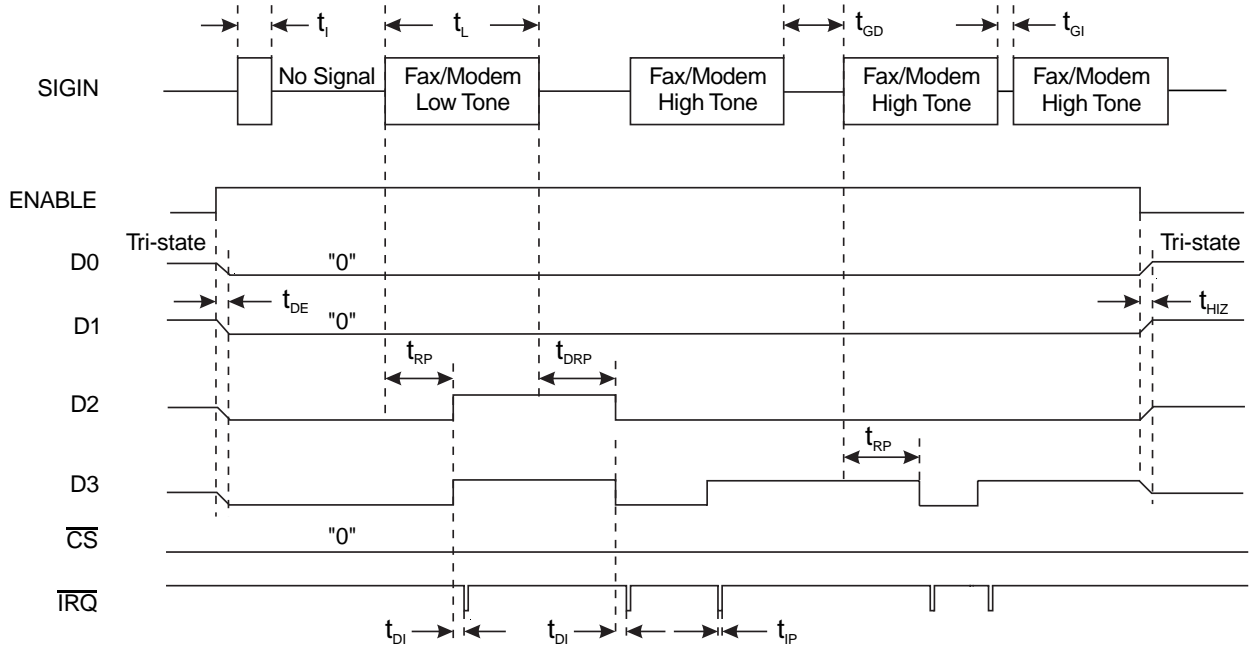

Figure 7: Timing Diagram: Fax/Modem Tones

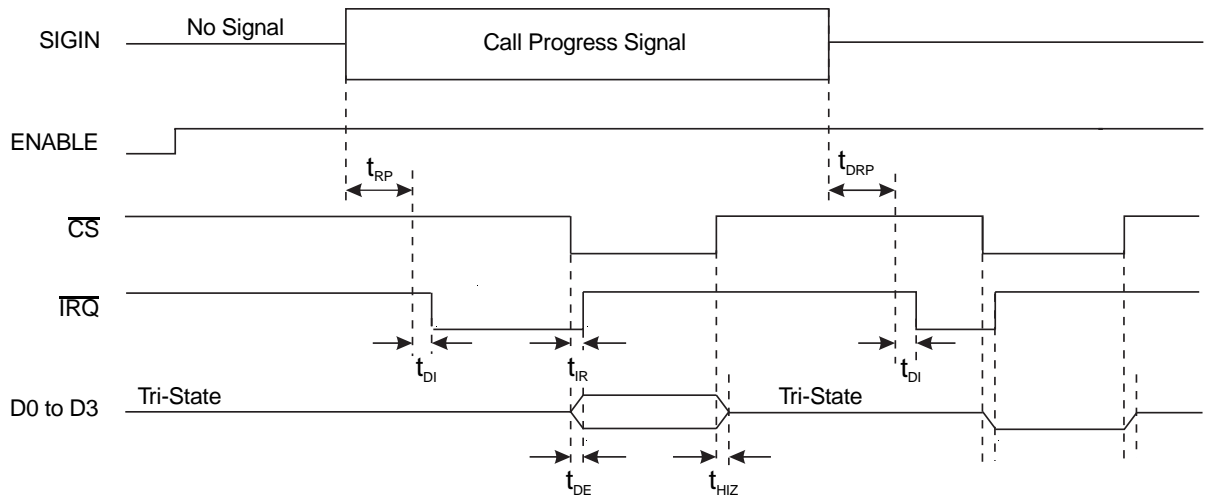

Figure 8: Bus Timing

### 6.3 Packaging

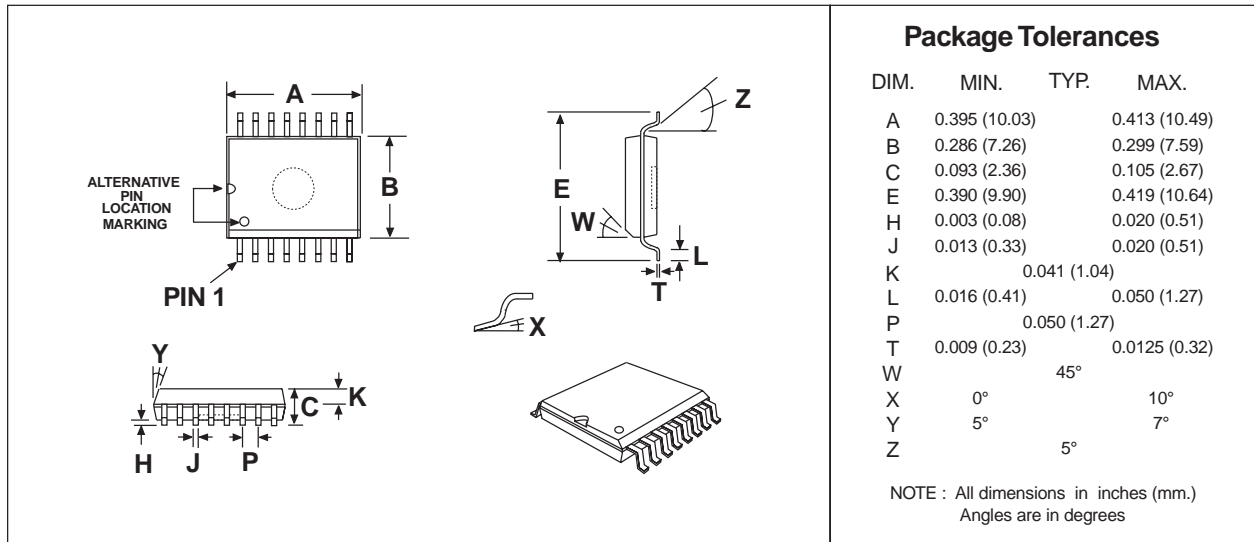

Figure 9: 16-pin SOIC Mechanical Outline: *Order as part no. MX663DW*

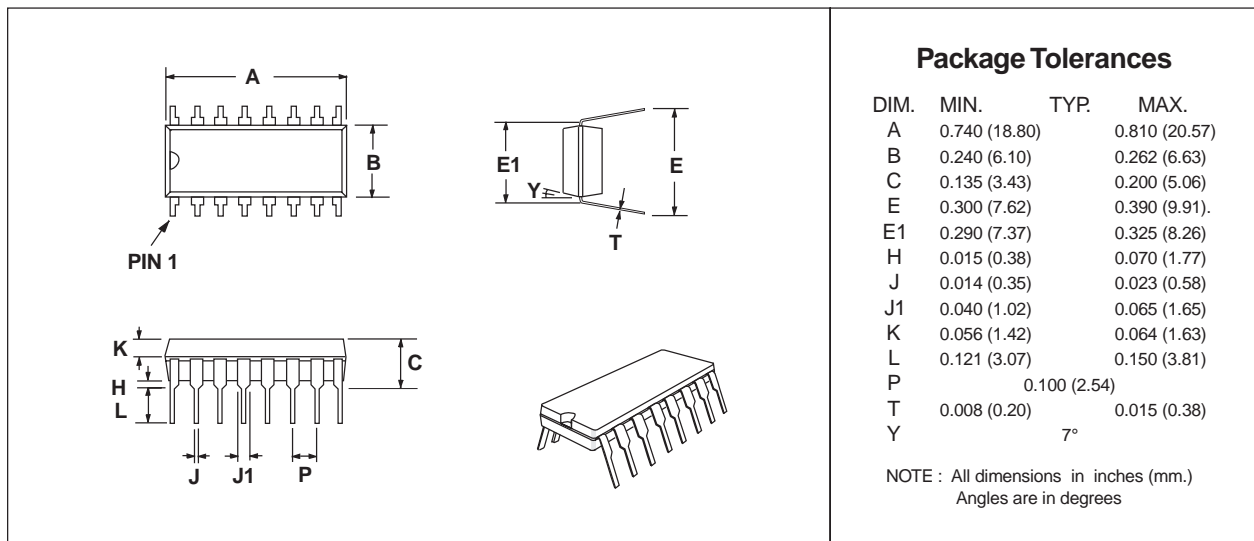

Figure 10: 16-pin PDIP Mechanical Outline: *Order as part no. MX663P*



**CML Microcircuits**

COMMUNICATION SEMICONDUCTORS

## CML Product Data

In the process of creating a more global image, the three standard product semiconductor companies of CML Microsystems Plc (*Consumer Microcircuits Limited (UK)*, *MX-COM, Inc (USA)* and *CML Microcircuits (Singapore) Pte Ltd*) have undergone name changes and, whilst maintaining their separate new names (*CML Microcircuits (UK) Ltd*, *CML Microcircuits (USA) Inc* and *CML Microcircuits (Singapore) Pte Ltd*), now operate under the single title **CML Microcircuits**.

These companies are all 100% owned operating companies of the CML Microsystems Plc Group and these changes are purely changes of name and do not change any underlying legal entities and hence will have no effect on any agreements or contacts currently in force.

### CML Microcircuits Product Prefix Codes

Until the latter part of 1996, the differentiator between products manufactured and sold from MXCOM, Inc. and Consumer Microcircuits Limited were denoted by the prefixes MX and FX respectively. These products use the same silicon etc. and today still carry the same prefixes. In the latter part of 1996, both companies adopted the common prefix: CMX.

This notification is relevant product information to which it is attached.

### CML Microcircuits (USA) [formerly MX-COM, Inc.] Product Textual Marking

On CML Microcircuits (USA) products, the 'MX-COM' textual logo is being replaced by a 'CML' textual logo.

Company contact information is as below:



**CML Microcircuits  
(UK) Ltd**

COMMUNICATION SEMICONDUCTORS

Oval Park, Langford, Maldon,  
Essex, CM9 6WG, England  
Tel: +44 (0)1621 875500  
Fax: +44 (0)1621 875600  
uk.sales@cmlmicro.com  
www.cmlmicro.com



**CML Microcircuits  
(USA) Inc.**

COMMUNICATION SEMICONDUCTORS

4800 Bethania Station Road,  
Winston-Salem, NC 27105, USA  
Tel: +1 336 744 5050,  
0800 638 5577  
Fax: +1 336 744 5054  
us.sales@cmlmicro.com  
www.cmlmicro.com



**CML Microcircuits  
(Singapore) Pte Ltd**

COMMUNICATION SEMICONDUCTORS

No 2 Kallang Pudding Road, 09-05/  
06 Mactech Industrial Building,  
Singapore 349307  
Tel: +65 7450426  
Fax: +65 7452917  
sg.sales@cmlmicro.com  
www.cmlmicro.com