



# MAXIM

## CMOS Octal 8-Bit D/A Converter

MX7228

### General Description

Maxim's MX7228 contains eight 8-bit voltage output digital-to-analog converters (DACs) with separate input latches and output buffers for simple micro-processor and TTL/CMOS interfacing. The MX7228 maintains 8-bit accuracy over the full operating temperature range without external trimming.

Internally, data transfer into the data registers is via a common 8-bit TTL/CMOS compatible input bus. Logic inputs A2, A1, and A0 control which DAC is loaded after WR goes low.

### Applications

- Minimum Component Count Analog Systems
- Digital Offset/Gain Adjustment
- Industrial Process Control
- Arbitrary Function Generators
- Automatic Test Equipment

### Typical Operating Circuit

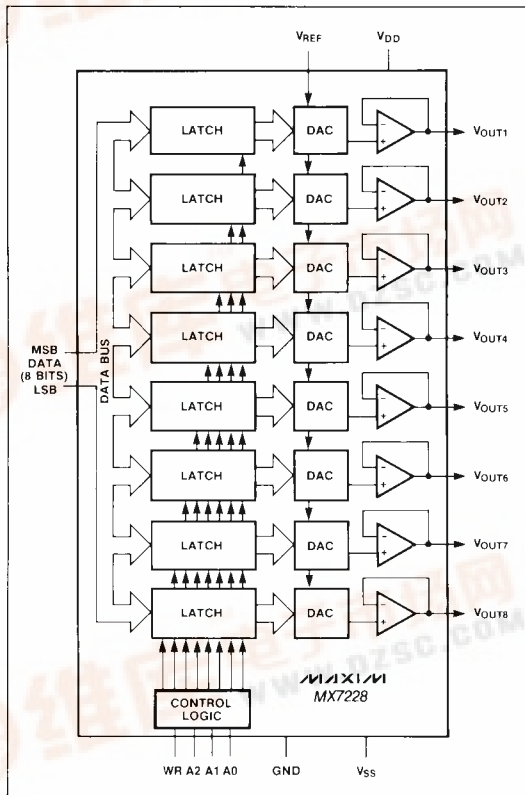

### Features

- ◆ Buffered Voltage Output
- ◆  $\mu$ P Compatible
- ◆ TTL/CMOS Logic Compatible
- ◆ Requires No External Adjustments
- ◆ 24-Pin Narrow DIP Package
- ◆ Operates from Single or Dual Supplies

### Ordering Information

PART	TEMP. RANGE	PACKAGE	ERROR
MX7228KN	0°C to +70°C	Plastic DIP	$\pm 2$ LSB
MX7228LN	0°C to +70°C	Plastic DIP	$\pm 1$ LSB
MX7228KCWG	0°C to +70°C	Wide SO	$\pm 2$ LSB
MX7228LCWG	0°C to +70°C	Wide SO	$\pm 1$ LSB
MX7228K/D	0°C to +70°C	Dice	$\pm 2$ LSB
MX7228KP	0°C to +70°C	PLCC	$\pm 2$ LSB
MX7228LP	0°C to +70°C	PLCC	$\pm 1$ LSB
MX7228BQ	-25°C to +85°C	CERDIP	$\pm 2$ LSB
MX7228CQ	-25°C to +85°C	CERDIP	$\pm 1$ LSB
MX7228TQ	-55°C to +125°C	CERDIP	$\pm 2$ LSB
MX7228UQ	-55°C to +125°C	CERDIP	$\pm 1$ LSB

### Pin Configuration

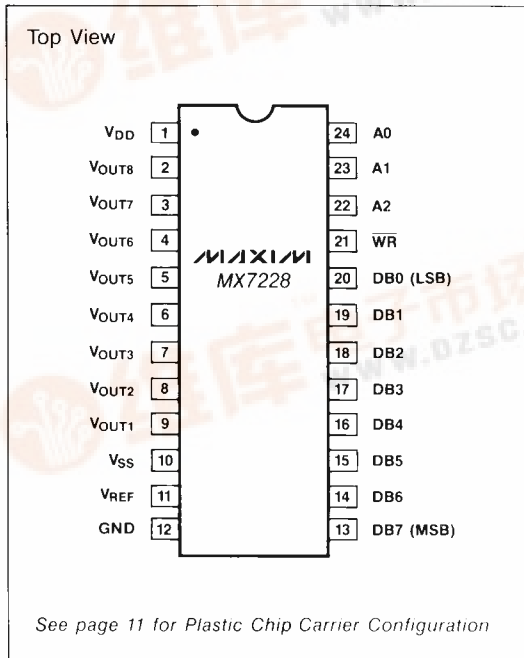

MAXIM is a registered trademark of Maxim Integrated Products.

Maxim Integrated Products 1



## CMOS Octal 8-Bit D/A Converter

### ABSOLUTE MAXIMUM RATINGS

$V_{DD}$ to GND	-0.3V, +17V	Operating Temperature Ranges	
$V_{DD}$ to $V_{SS}$	-0.3V, +24V		
$V_{SS}$ to GND	-7V, $V_{DD}$	MX7228K, L	0°C to +70°C
Digital Input Voltage to GND	-0.3V, $V_{DD}$	MX7228B, C	-25°C to +85°C
$V_{REF}$ to GND	-0.3V, $V_{DD}$	MX7228T, U	-55°C to +125°C
$V_{OUT}$ to GND (Note 1)	$V_{SS}$ , $V_{DD}$	Storage Temperature	-65°C to +165°C
Power Dissipation (Any Package) to +75°C	1000mW	Lead Temperature (Soldering 10 sec.)	+300°C
Derating above +75°C	12mW/°C		

Stresses above those listed under "Absolute Maximum Ratings" may cause permanent damage to the device. These are stress ratings only, and functional operation of the device at these or any other conditions above those indicated in the operational sections of the specifications is not implied. Exposure to absolute maximum rating conditions for extended periods may affect device reliability.

### ELECTRICAL CHARACTERISTICS—Dual Supply Operation

( $V_{DD}$  = +10.8V to +16.5V,  $V_{SS}$  = -5V  $\pm$  10%, GND = 0V,  $V_{REF}$  = +2V to +10V,  $R_L$  = 2k,  $C_L$  = 100pF,  $T_A$  =  $T_{MIN}$  to  $T_{MAX}$  unless otherwise noted.)

PARAMETER	SYMBOL	CONDITIONS	MIN	TYP	MAX	UNITS
<b>STATIC PERFORMANCE</b>						
Resolution			8			Bits
Total Unadjusted Error		$V_{DD} = 15V \pm 10\%$ $V_{REF} = 10V$	K,B,T L,C,U		+2 +1	LSB
Relative Accuracy	INL		K,B,T L,C,U		+1 +1/2	LSB
Differential Nonlinearity	DNL	Guaranteed Monotonic			+1	LSB
Full Scale Error			K,B,T L,C,U		+1 +1/2	LSB
Full Scale Tempco		$V_{REF} = 10V$		5		ppm/°C
Zero Code Error		$T_A = 25^\circ C$	K,B,T L,C,U		+25 +15	mV
		$T_A = T_{MIN}$ to $T_{MAX}$	K,B,T L,C,U		+30 $\pm 20$	
Zero Code Tempco				30		$\mu V/^\circ C$
<b>REFERENCE INPUT</b>						
Reference Input Range		(Note 2)	2		10	V
Reference Input Resistance			2			k $\Omega$
Reference Input Capacitance		(Note 3) DAC loaded with 1s			500	pF
AC Feedthrough		(Note 4)		-70		dB
<b>DIGITAL INPUTS</b>						
Input High Voltage	$V_{INH}$		2.4			V
Input Low Voltage	$V_{INL}$				0.8	V
Digital Input Leakage Current		$V_{IN} = 0V$ or $V_{DD}$			+1	$\mu A$
Digital Input Capacitance		(Note 3)			8	pF

**Note 1:** The outputs may be shorted to GND provided that the power dissipation of the package is not exceeded. Typical short circuit current to GND is 25mA.

**Note 2:**  $V_{OUT}$  must be less than  $V_{DD}$  by 3.5V to ensure correct operation.

**Note 3:** Sample tested at +25°C to ensure compliance.

**Note 4:**  $V_{REF}$  = 10kHz, 8V peak-to-peak sine wave.

**Note 5:** Code transition all 0s to all 1s.  $V_{REF} = 0V$ ;  $WR = V_{DD}$ .

**Note 6:** Code transition all 0s to all 1s.  $V_{REF} = 10V$ ;  $WR = 0V$ .

## CMOS Octal 8-Bit D/A Converter

### ELECTRICAL CHARACTERISTICS—Dual Supply Operation (Continued)

( $V_{DD} = +10.8V$  to  $+16.5V$ ,  $V_{SS} = -5V$   $\pm 10\%$ ,  $GND = 0V$ ,  $V_{REF} = +2V$  to  $+10V$ ,  $R_L = 2k$ ,  $C_L = 100pF$ ,  $T_A = T_{MIN}$  to  $T_{MAX}$  unless otherwise noted.)

PARAMETER	SYMBOL	CONDITIONS	MIN	TYP	MAX	UNITS
<b>DYNAMIC PERFORMANCE (Note 3)</b>						
Voltage Output Slew Rate			2			V/ $\mu$ s
$V_{OUT}$ Settling Time		To +1/2 LSB, $V_{REF} = 10V$			5	$\mu$ s
Digital Feedthrough		(Note 5)		50		nV-sec
Digital Crosstalk		(Note 6)		50		nV-sec
Output Load Resistance		$V_{OUT} = 10V$	2			k $\Omega$
<b>POWER REQUIREMENTS</b>						
Positive Supply Range	$V_{DD}$	For specified performance	10.8		16.5	V
Negative Supply Range	$V_{SS}$	For specified performance	-4.5		-5.5	V
Positive Supply Current (Note 7)	$I_{DD}$	$T_A = 25^\circ C$	All		16	mA
		$T_A = T_{MIN}$ to $T_{MAX}$	K,B,L,C T,U		20 22	
Negative Supply Current (Note 7)	$I_{SS}$	$T_A = 25^\circ C$	All		14	mA
		$T_A = T_{MIN}$ to $T_{MAX}$	K,B,L,C T,U		18 20	
<b>SWITCHING CHARACTERISTICS (Note 3)</b>						
Address to WR Setup	$t_1$		0			ns
Address to WR Hold	$t_2$		0			ns
Data to WR Setup	$t_3$	$T_A = 25^\circ C$	All		70	ns
		$T_A = T_{MIN}$ to $T_{MAX}$	K,L,B,C T,U		90 100	
Data to WR Hold	$t_4$		10			ns
WR Pulse Width	$t_5$	$T_A = 25^\circ C$	All		95	ns
		$T_A = T_{MIN}$ to $T_{MAX}$	K,L,B,C T,U		120 150	

### ELECTRICAL CHARACTERISTICS—Single +15V Supply Operation

( $V_{DD} = +15V \pm 10\%$ ,  $V_{SS} = GND = 0V$ ,  $V_{REF} = +10V$ ,  $R_L = 2k$ ,  $C_L = 100pF$ ,  $T_A = T_{MIN}$  to  $T_{MAX}$  unless otherwise noted.)

PARAMETER	SYMBOL	CONDITIONS	MIN	TYP	MAX	UNITS
<b>STATIC PERFORMANCE</b>						
Resolution			8			Bits
Total Unadjusted Error		K,B,T L,C,U			+2 +1	LSB
Differential Nonlinearity		Guaranteed Monotonic			+1	LSB
<b>REFERENCE INPUT</b> All specifications are the same as for dual supplies.						
<b>DIGITAL INPUTS</b> All specifications are the same as for dual supplies.						
<b>DYNAMIC PERFORMANCE</b> All specifications are the same as for dual supplies.						
<b>POWER REQUIREMENTS</b>						
Positive Supply Range	$V_{DD}$	For specified performance	13.5		16.5	V
Positive Supply Current (Note 7)	$I_{DD}$	$T_A = 25^\circ C$	All		16	mA
		$T_A = T_{MIN}$ to $T_{MAX}$	K,B,L,C T,U		20 22	
<b>SWITCHING CHARACTERISTICS</b> All specifications are the same as for dual supplies.						

## CMOS Octal 8-Bit D/A Converter

### ELECTRICAL CHARACTERISTICS—+5V Supply Operation

( $V_{DD} = +5V \pm 5\%$ ,  $V_{SS} = 0$  to  $-5V \pm 10\%$ ,  $GND = 0V$ ,  $V_{REF} = +1.25V$ ,  $R_L = 2k$ ,  $C_L = 100pF$ ,  $T_A = T_{MIN}$  to  $T_{MAX}$  unless otherwise noted)

PARAMETER	SYMBOL	CONDITIONS	MIN	TYP	MAX	UNITS
<b>STATIC PERFORMANCE</b>						
Resolution			8			Bits
Differential Nonlinearity		Guaranteed Monotonic			+1	LSB
Full Scale Error		K,B,T L,C,U			$\pm 4$ $\pm 2$	LSB
Zero Code Error		$T_A = 25^\circ C$ K,B,T L,C,U			40 30	mV
<b>REFERENCE INPUT</b>						
Reference Input Range		(Note 2)	1.2		1.3	V
Reference Input Resistance			2			k $\Omega$
Reference Input Capacitance		(Note 3) DAC loaded with 1s			500	pF
<b>DIGITAL INPUTS</b> All specifications are the same as for dual supplies.						
<b>DYNAMIC PERFORMANCE</b> All specifications are the same as for dual supplies.						
<b>POWER REQUIREMENTS</b>						
Positive Supply Range	$V_{DD}$	For Spec Performance	4.75		5.25	V
Positive Supply Current (Note 7)	$I_{DD}$	$T_A = 25^\circ C$	All		16	mA
		$T_A = T_{MIN}$ to $T_{MAX}$	K,B,L,C T,U		20 22	
Negative Supply Current (Note 7)	$I_{SS}$	$T_A = 25^\circ C$	All		14	mA
		$T_A = T_{MIN}$ to $T_{MAX}$	K,B,L,C T,U		18 20	
<b>SWITCHING CHARACTERISTICS (Note 3)</b>						
Address to $\overline{WR}$ Setup	$t_1$		0			ns
Address to $\overline{WR}$ Hold	$t_2$		0			ns
Data to $\overline{WR}$ Setup	$t_3$	$T_A = 25^\circ C$	All	100		ns
		$T_A = T_{MIN}$ to $T_{MAX}$	K,L,B,C T,U	140 175		
Data to $\overline{WR}$ Hold	$t_4$		10			ns
$\overline{WR}$ Pulse Width	$t_5$	$T_A = 25^\circ C$	All	125		ns
		$T_A = T_{MIN}$ to $T_{MAX}$	K,L,B,C T,U	160 200		

**Note 1:** The outputs may be shorted to GND provided that the power dissipation of the package is not exceeded. Typical short circuit current to GND is 25mA.

**Note 2:**  $V_{OUT}$  must be less than  $V_{DD}$  by 3.5V to ensure correct operation.

**Note 3:** Sample tested at  $+25^\circ C$  to ensure compliance.

**Note 4:**  $V_{REF} = 10kHz$ , 8V peak-to-peak sine wave.

**Note 5:** Code transition all 0s to all 1s.  $V_{REF} = 0V$ ;  $\overline{WR} = V_{DD}$ .

**Note 6:** Code transition all 0s to all 1s.  $V_{REF} = 10V$ ;  $\overline{WR} = 0V$ .

**Note 7:** Outputs unloaded.

# CMOS Octal 8-Bit D/A Converter

**MX7228**

## Digital Inputs and Interface Logic

The digital inputs are compatible with both TTL and 5V CMOS logic, however the power supply current ( $I_{DD}$ ) is somewhat dependent on input logic level. Supply current is specified for TTL input levels (worst case) but is reduced (by about  $450\mu A$ ) when the logic inputs are driven near GND or greater than 4 volts above GND.

Table 1 shows control logic truth table for  $\overline{WR}$ , A2, A1, and A0 operation. When  $\overline{WR}$  is low, the input latch of the selected DAC is transparent, and the DAC's output responds to the activity on the data bus. The data is latched into the addressed DAC's latch on the rising edge of the  $\overline{WR}$  signal. Figure 1 shows the timing diagram for the MX7228.

**Table 1. Control Logic Truth Table**

WR	A2	A1	A0	OPERATION
H	X	X	X	No operation Device not selected
L	L	L	L	DAC 1 Transparent
R	L	L	L	DAC 1 Latched
L	L	L	H	DAC 2 Transparent
L	L	H	L	DAC 3 Transparent
L	L	H	H	DAC 4 Transparent
L	H	L	L	DAC 5 Transparent
L	H	L	H	DAC 6 Transparent
L	H	H	L	DAC 7 Transparent
L	H	H	H	DAC 8 Transparent

H = High State, L = Low State, X = Don't Care, R = Rising Edge

## Detailed Description

The MX7228 has eight matched voltage output digital-to-analog converters (DACs). The DACs are "inverted" R-2R ladder networks which convert 8 digital bits into equivalent analog output voltages in proportion to the

applied reference voltage. All 8 DACs in the MX7228 share the same reference input ( $V_{REF}$ ) and GND. A simplified circuit diagram of one of the eight DACs is provided in Figure 2.

## $V_{REF}$ Input

The voltage at  $V_{REF}$  sets the full-scale output of the DACs. The input impedance of the  $V_{REF}$  pin is code dependent. The lowest value, approximately 2 kohms, occurs when the input code of all eight DACs is 01010101. The maximum value of infinity occurs when all of the input codes of the eight DACs is 00000000. Because the input resistance at  $V_{REF}$  is code dependent, the DACs' reference source should not have an output impedance more than 4 ohms. The capacitance at  $V_{REF}$  is also code dependent and typically varies from 120pF to 350pF.

$V_{OUT1}$ ,  $V_{OUT2}$ ,  $V_{OUT3}$ ,  $V_{OUT4}$ ,  $V_{OUT5}$ ,  $V_{OUT6}$ ,  $V_{OUT7}$ , and  $V_{OUT8}$  can be represented by a digitally programmable voltage source as:

$$V_{OUT} = N_b \times V_{REF}/256$$

where  $N_b$  is the numeric value of the DAC's binary input code.

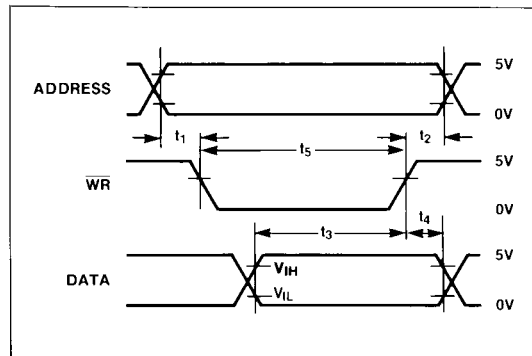

Figure 1. Write Cycle Timing Diagram

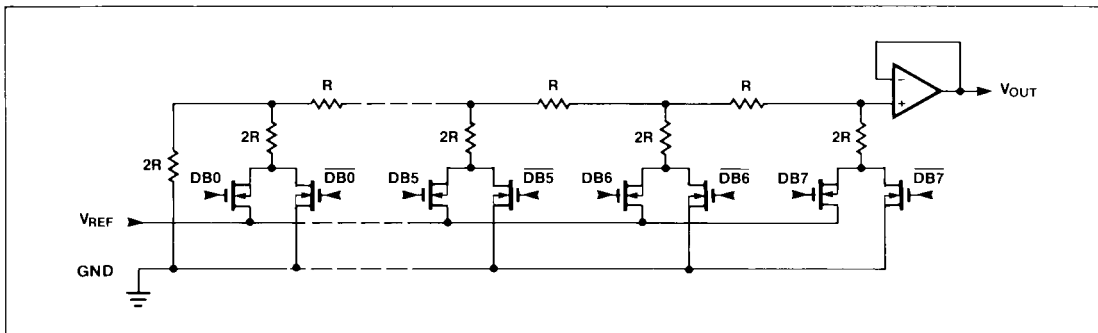

Figure 2. DAC Circuit Diagram

## CMOS Octal 8-Bit D/A Converter

### Output Buffer Amplifiers

All voltage outputs are internally buffered by precision unity gain followers which slew at greater than  $2V/\mu s$ . The output settles to  $\pm 1/2$  LSB in less than  $5\mu s$  when driving  $2k\Omega$  in parallel with  $100pF$  with a full scale transition ( $0V$  to  $+10V$  or  $+10V$  to  $0V$ ). The buffers will also drive  $2k\Omega$  in parallel with  $500pF$  to  $10V$  levels without oscillation. Typical dynamic response and settling performance of the MX7228 are shown in Figures 3 and 4.

A simplified circuit diagram of an output buffer is shown in Figure 5. Input common mode range to GND is provided by a PMOS input structure. The output circuitry incorporates both a constant current source and an actively driven n-channel device. The actively driven n-channel device aids in discharging large output capacitances.

The MX7228 can operate from either a single supply or dual supplies. The output buffer amplifiers are the only part of the MX7228 that receive  $V_{SS}$  power. Operating the MX7228 from dual supplies will improve the negative going output settling time near GND. In addition, the output amplifier can sink  $500\mu A$  when operating with dual supplies. The use of dual supplies also extends the input reference voltage range. When operating with a single supply, the output sink current decreases when the output approaches 0 volts (see Figure 6).

The output amplifier broadband noise is approximately  $50\mu V_{RMS}$  and is not strongly power supply voltage dependent. The output impedance of the output buffer is approximately  $1\Omega$ .

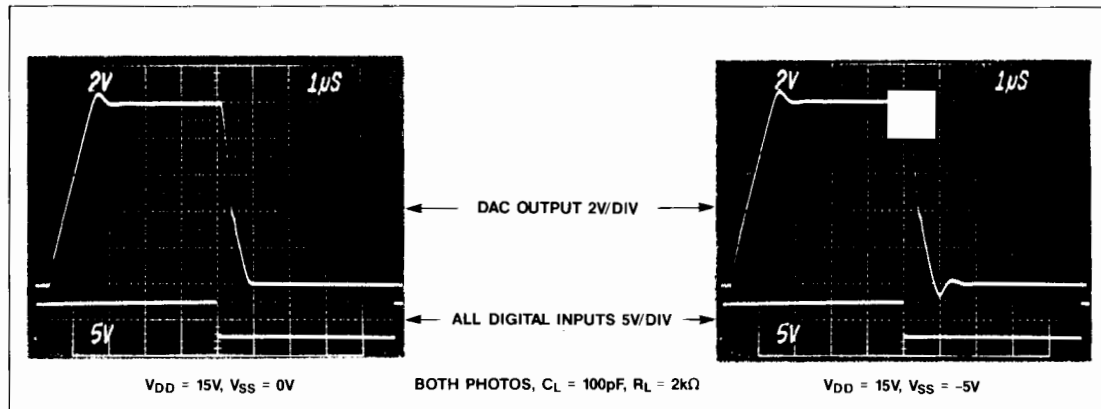

Figure 3. Dynamic Response

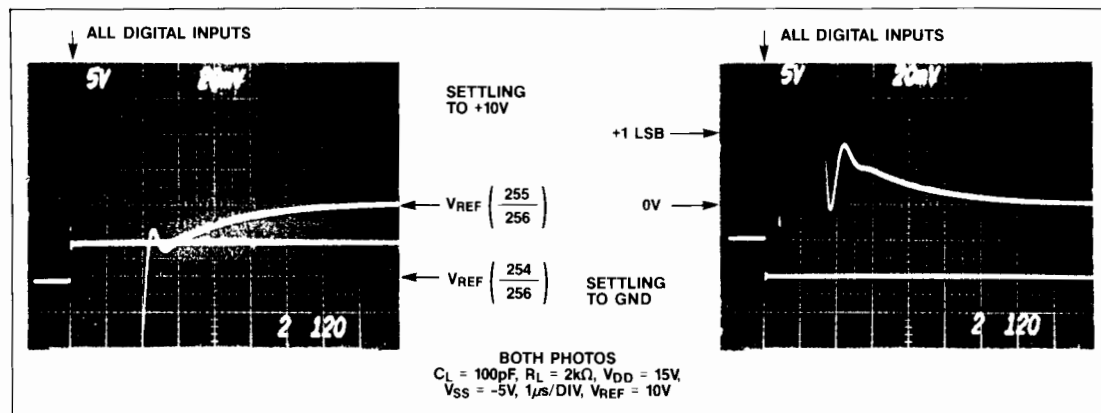

Figure 4. Dynamic Response

# CMOS Octal 8-Bit D/A Converter

MX7228

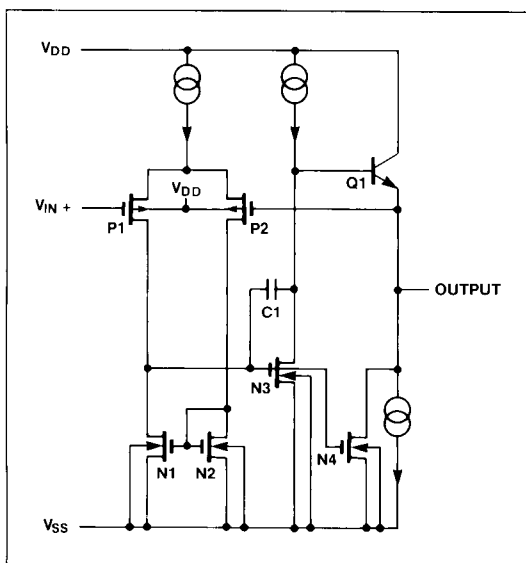

Figure 5. Output Buffer Amplifier

## Applications Information

### Power Supply and Reference Operating Ranges

The MX7228 is fully specified to operate between  $+12V \pm 10\%$  and  $+15V \pm 10\%$  (10.8V to 16.5V), and with  $V_{SS}$  from 0V to -5.5V. 8 bit performance is guaranteed for single supply operation ( $V_{SS} = 0V$ ), however, zero code error is improved with  $V_{SS} = -5V$ .

For adequate DAC and buffer operation,  $V_{REF}$  must always be below  $V_{DD}$  by at least 3.5V.

### Power Supply Management

Careful PCB layout techniques should be used to minimize crosstalk between  $V_{REF}$ , GND, and the digital inputs. This is particularly important if the reference input is driven from an AC source. Bypass capacitors ( $0.1\mu F$  in parallel with  $6.8\mu F$ ) should be used between  $V_{DD}$  and GND (also between  $V_{SS}$  and GND if  $V_{SS}$  is -5V).

### Unipolar Output

In unipolar operation, the reference voltage is the same polarity as the output voltage. Since the reference voltage must always be positive with respect to GND, the output voltage is also positive with respect to GND. An example of a unipolar circuit configuration is shown in Figure 7. The unipolar code is given in Table 2.

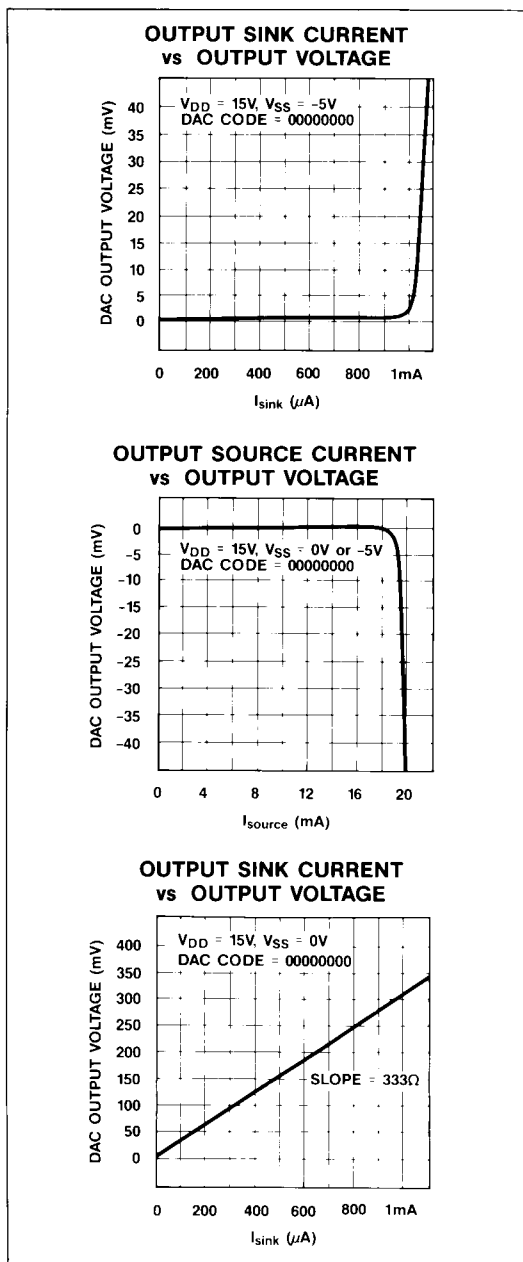

Figure 6. Output Sink/Source Current vs. Output Voltage

## CMOS Octal 8-Bit D/A Converter

Table 2. Unipolar Code Table

DAC CONTENTS		ANALOG OUTPUT
MSB	LSB	
1 1 1 1	1 1 1 1	$+V_{REF} \left( \frac{255}{256} \right)$
1 0 0 0	0 0 0 1	$+V_{REF} \left( \frac{129}{256} \right)$
1 0 0 0	0 0 0 0	$+V_{REF} \left( \frac{128}{256} \right) = + \frac{V_{REF}}{2}$
0 1 1 1	1 1 1 1	$+V_{REF} \left( \frac{127}{256} \right)$
0 0 0 0	0 0 0 1	$+V_{REF} \left( \frac{1}{256} \right)$
0 0 0 0	0 0 0 0	0V

Note: 1 LSB =  $(V_{REF})(2^{-8}) = +V_{REF} \left( \frac{1}{256} \right)$

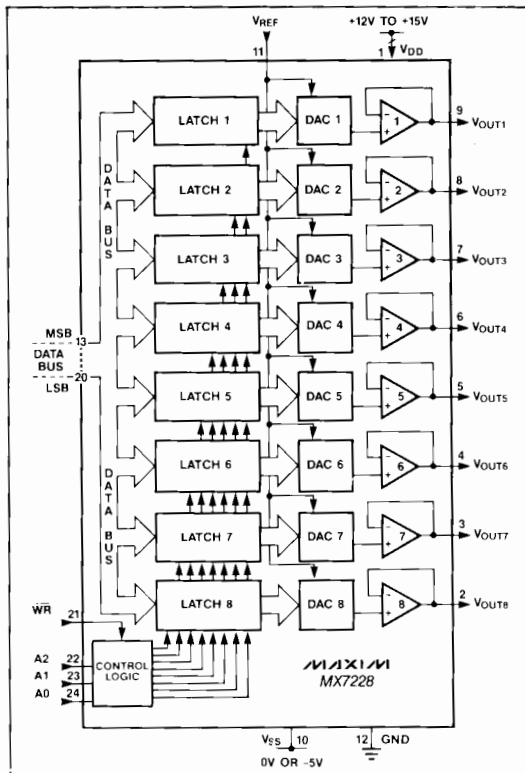

Figure 7. Unipolar Output Circuit

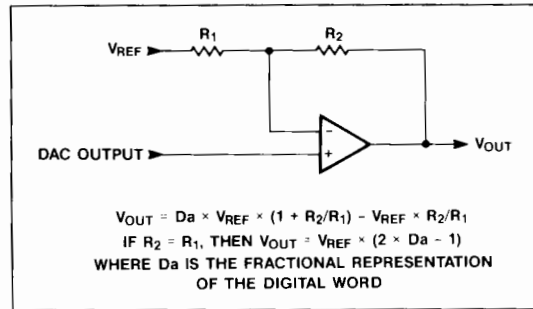

Figure 8. Bipolar Output Circuit

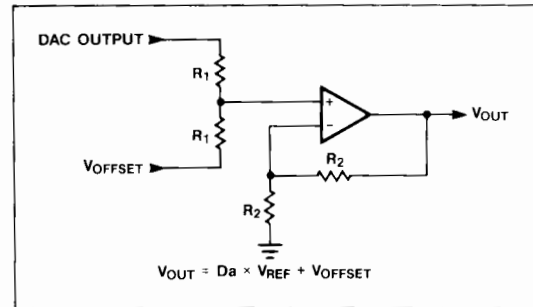

Figure 9. Offset Circuit

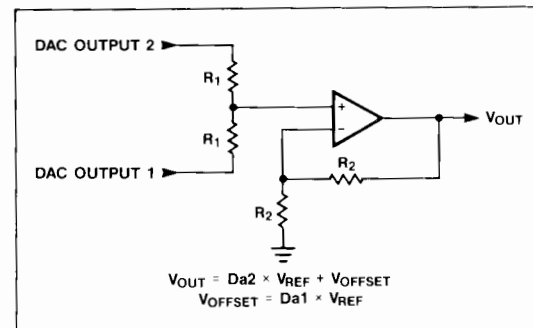

Figure 10. Offset Circuit



## CMOS Octal 8-Bit D/A Converter

### Bipolar Output

Each DAC output may be configured for bipolar operation using the circuit in Figure 8. One op amp and two resistors are needed per channel. Table 3 shows the digital code versus output voltage for Figure 8 assuming R1=R2.

Table 3. Bipolar Code Table

DAC CONTENTS		ANALOG OUTPUT
MSB	LSB	
1 1 1 1	1 1 1 1	$+V_{REF} \left( \frac{127}{128} \right)$
1 0 0 0	0 0 0 1	$+V_{REF} \left( \frac{1}{128} \right)$
1 0 0 0	0 0 0 0	0V
0 1 1 1	1 1 1 1	$-V_{REF} \left( \frac{1}{128} \right)$
0 0 0 0	0 0 0 1	$-V_{REF} \left( \frac{127}{128} \right)$
0 0 0 0	0 0 0 0	$-V_{REF} \left( \frac{128}{128} \right) = -V_{REF}$

### Offsetting DAC Outputs

Each DAC can be offset using the circuit shown in Figure 9. If the op amp does not have a negative supply, then its common mode voltage range and output voltage range must include GND. Also, one DAC can provide the output offset for another DAC as shown in Figure 10.

### Using an AC Reference

In applications where  $V_{REF}$  has AC signal components, the MX7228 has multiplying capabilities within the limits of the  $V_{REF}$  input range specifications. Figure 11 shows a technique for applying an AC signal to the MX7228. Since all eight DACs share a common reference, they all will be AC modulated. Output

distortion is typically less than 0.1% for frequencies up to 50kHz.

### Generating $V_{SS}$

The performance of the MX7228 is specified with and without a  $V_{SS}$  supply. When the improved performance of dual supply operation is desired, but only a single supply is available, a negative supply can be generated using any of the circuits shown in Figure 12.

### Digital Interface Applications

Figures 13 through 16 shown examples of interfacing the MX7228 to most popular microprocessors.

### 5V Operation

The MX7228 can also be used with a single 5V power supply or a  $\pm 5V$  power supply. The timing specifications are degraded, and the reference voltage range is reduced. The DNL of each DAC remains at  $\pm 1$  LSB guaranteeing monotonicity. For devices with a negative offset and no negative supply there is a possibility, near zero, that the DAC will not change when the DAC code is incremented. Once the DAC has reached the offset voltage of the output buffer, the DAC will begin to increment in a normal fashion. Since the LSB voltage is only a few millivolts, care should be used in decoupling supplies, ground loops, etc.

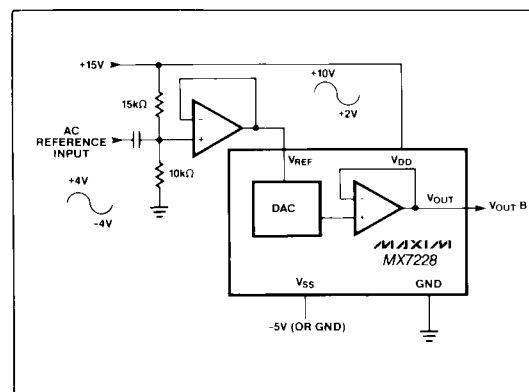

Figure 11. AC Reference Input Circuit

## CMOS Octal 8-Bit D/A Converter

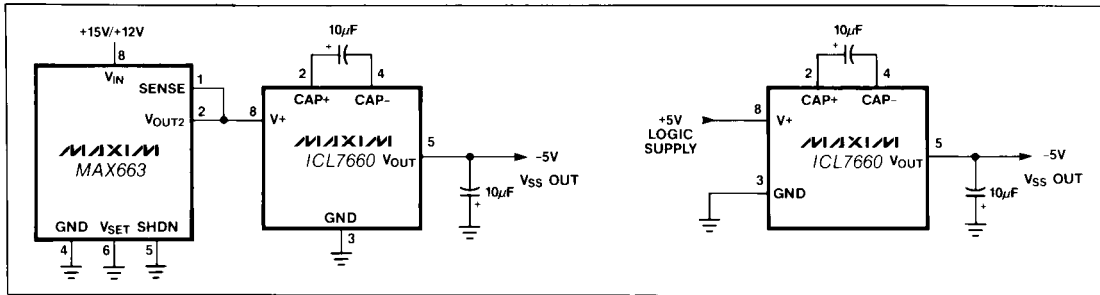

Figure 12. Generating -5V for  $V_{SS}$

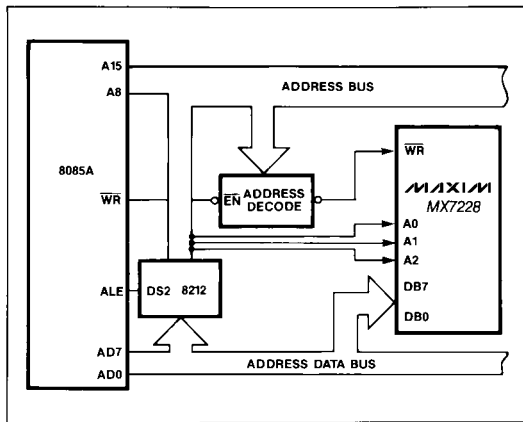

Figure 13. MX7228 to 8085A Interface

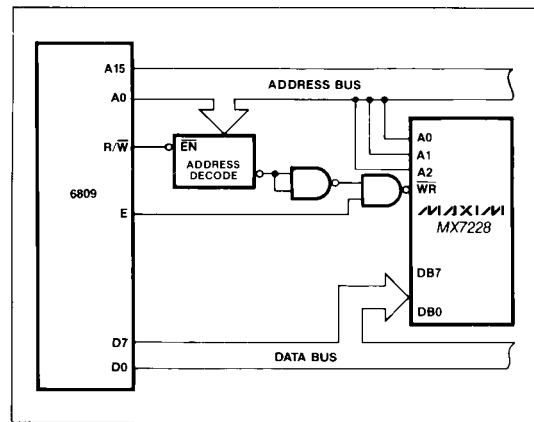

Figure 14. MX7228 to 6809 Interface

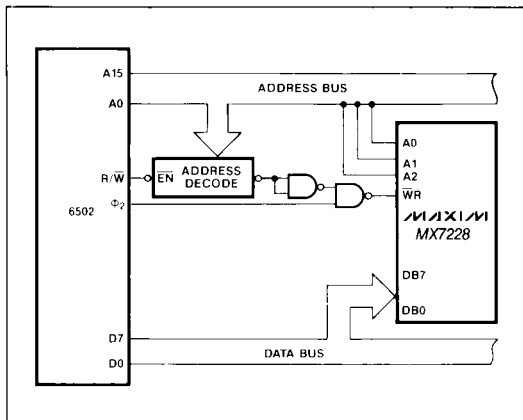

Figure 15. MX7228 to 6502 Interface

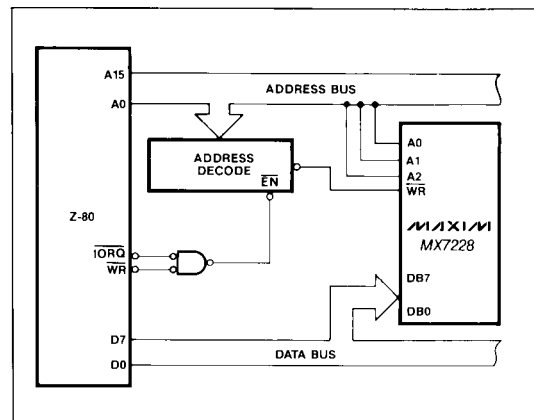

Figure 16. MX7228 to Z-80 Interface

# CMOS Octal 8-Bit D/A Converter

**MX7228**

## Pin Configuration (continued)

Top View

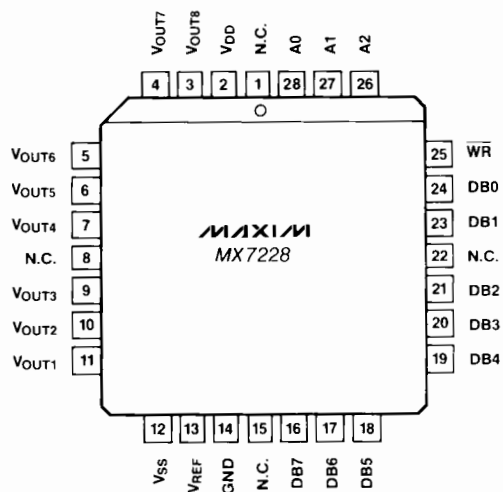
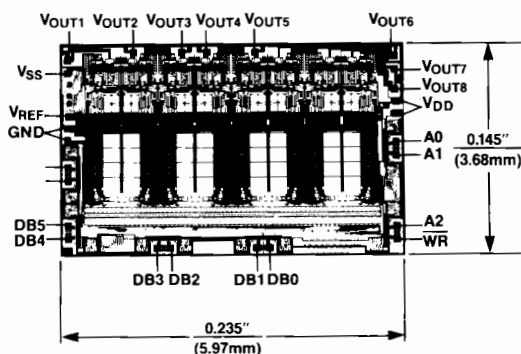

28 Lead Plastic Chip Carrier (Quad Pak)

## Package Information

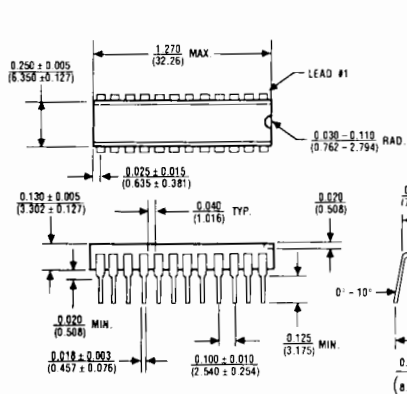

24 Lead Plastic Narrow DIP (NG)

$\theta_{JA} = 120^{\circ}\text{C/W}$   
 $\theta_{JC} = 60^{\circ}\text{C/W}$

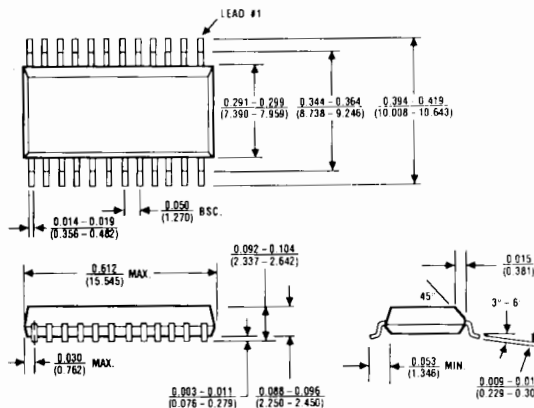

24 Lead Small Outline, Wide (WG)

$\theta_{JA} = 85^{\circ}\text{C/W}$   
 $\theta_{JC} = 45^{\circ}\text{C/W}$

**MX7228**

# CMOS Octal 8-Bit D/A Converter

## Package Information (continued)

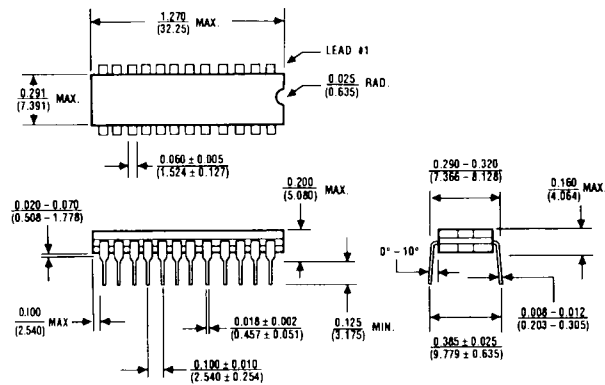

**24 Lead Narrow CERDIP (RG)**

$\theta_{JA} = 80^{\circ}\text{C/W}$   
 $\theta_{JC} = 40^{\circ}\text{C/W}$

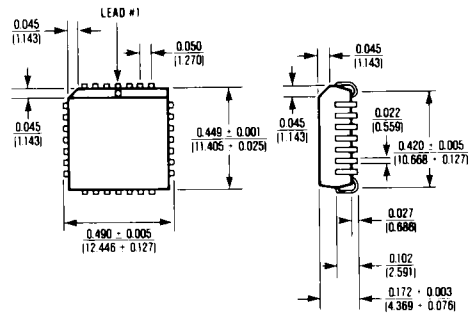

**28 Lead Plastic Chip Carrier (Quad Pak) (QI)**

$\theta_{JA} = 100^{\circ}\text{C/W}$   
 $\theta_{JC} = 45^{\circ}\text{C/W}$

Maxim cannot assume responsibility for use of any circuitry other than circuitry entirely embodied in a Maxim product. No circuit patent licenses are implied. Maxim reserves the right to change the circuitry and specifications without notice at any time.

12 Maxim Integrated Products, 120 San Gabriel Drive, Sunnyvale, CA 94086 (408) 737-7600