

MX-COM, INC. MiXed Signal ICs

DATA BULLETIN

MX826

AMPS/NAMPS SYSTEM AUDIO PROCESSOR

**C-BUS
COMPATIBLE**

PRELIMINARY INFORMATION

Features

- Full-Duplex Audio Processing for AMPS/ NAMPS Cellular Systems
- On-Chip Speech and SAT Capabilities – TX/RX Filtering & Gain – SAT Channel Pre-/De-Emphasis – Deviation Limiter
- Serial μ Processor Interface
- “Sidetone” Output Available
- Access to External Processes – Companding – Signaling – VSR Codec (Store/Play)
- HandsFree Compatibility
- Powersave (Low-Current) Settings

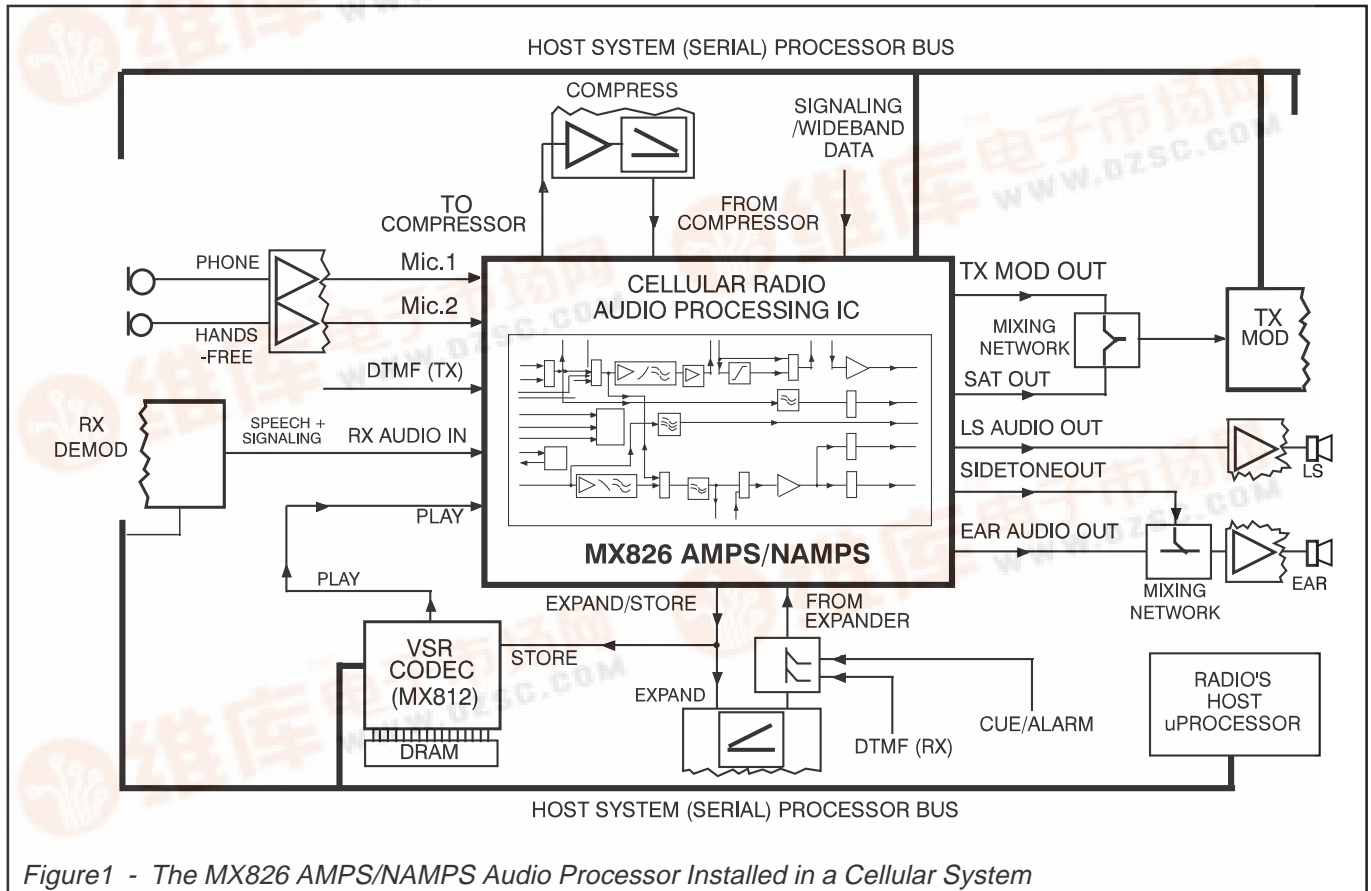
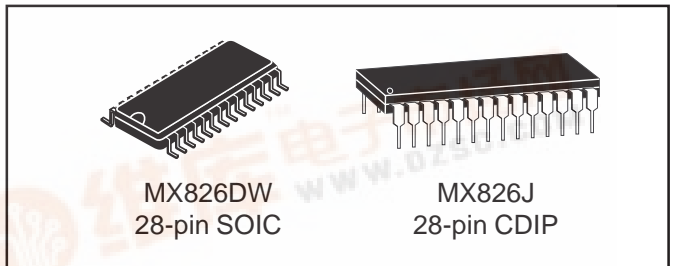

Figure1 - The MX826 AMPS/NAMPS Audio Processor Installed in a Cellular System



Description

The MX826 is a μ Processor controlled full-duplex audio processor on a single-chip with separate TX and RX paths to provide all the filter/gain/limiting functions necessary to pre-process audio, wideband-data and SAT cellular communications systems using the AMPS/NAMPS or TACS/ETACS/JTACS specifications.

Selectable inputs available to the transmit path are: a choice of two microphones and DTMF/signaling, with access, in this path, to external compression circuitry. Operationally the TX path provides input gain/filtering, a deviation limiter and TX Modulation Drive controls.

In the RX path the SAT signal is separated from the incoming audio via a filter block and made available at a separate pin for mixing externally with the TX Modulation Drive.

The RX path consists of an input gain/filter block for

voice, inputs from an external audio expansion system and an output gain control driving either a loudspeaker system or earpiece.

Unique to the MX816/826/836 cellular audio processors is the ability to route audio (TX or RX) to an external Voice Store and Retrieve (VSR) device such as the MX802 or MX812 thus providing the radio system with a voice answering and announcement facility using external DRAM.

As a member of the DBS800 family, the MX826 follows C-BUS protocol. (C-BUS is the serial interface used by all DBS800 integrated circuits.)

The MX826, a low-power CMOS device which reduces the amount of microcircuits and components required in a cellular audio system by providing more functions on a single chip, is available in 28-pin SOIC and CDIP packages.

Pin	Function
1	Xtal: The output of the on-chip clock oscillator.
2	Xtal/Clock: The input to the on-chip clock oscillator. A Xtal or externally derived clock (f_{XTAL}) should be connected here. Note that operation of the MX826 without a suitable Xtal or clock input may cause device damage. See Figure 2 (notes).
3	Serial Clock: The "C-BUS" serial data clock input. This clock, produced by the μ Controller, is used for transfer timing of commands and data to the MX826. See Timing Diagrams.
4	Command Data: The "C-BUS" serial data input from the μ Controller. Data is loaded to the MX826 in 8-bit bytes, MSB (B7) first, and LSB (B0) last, synchronized to the Serial Clock. See Timing Diagrams.
5	Chip Select (\overline{CS}): The "C-BUS" data loading control function. This input is provided by the μ Controller. Data transfer sequences are initiated, completed or aborted by this signal. See Timing Diagrams.
6	V_{BIAS}: The internal circuitry bias line, held at $V_{DD}/2$ this pin must be decoupled to V_{SS} . See Figure 2.
7	Rx Audio In: Normally taken from the radio's discriminator output, this input has a $1M\Omega$ internal resistor to V_{BIAS} and requires to be connected via a capacitor.
8	Expand/Store: A common output that can be used as either an input to an external audio expander or the input to a voice storage medium such as the MX812. Components relevant to the external device requirements should be used at this output. See Figures 2 and 3.
9	(Expanded) Audio In: The audio input, via SW5, from an external expander or audio mixing function. This input has a $1M\Omega$ internal resistor to V_{BIAS} and requires to be connected via a capacitor. See Figures 2 and 3.
10	TX Mod Out: The composite TX audio output to the transmitter modulator from a variable attenuation stage (11 _H). This output is set to V_{BIAS} via an internal $1M\Omega$ resistor when set to Powersave or OFF.
11	LS Audio Out: An audio output of the Rx path (or selected audios, see Figure 3) for a loudspeaker system. This is available for handsfree operation. This output can be connected to V_{BIAS} when not required, by SW6 (Configuration Command (10 _H)). A driver amplifier may be required.
<p>Notes on Inputs: To minimize aliasing effects, lowpass filtering may be required at the inputs to this device (especially those supplied from switched-capacitor-type devices) to ensure the input spectrum is kept below 63kHz.</p>	

Pin	Function
12	Ear Audio Out: An audio output of the Rx path (or selected audios), available as an output for a handset earpiece. This output, in parallel with the LS Audio Out function, can be connected to V_{BIAS} when not required, by SW7 (Configuration Command (10 _H)). A driver amplifier may be required.
13	Sidetone: A switched "sidetone" from the microphone inputs made available for mixing externally with the "Ear" audio. See Figure 3.
14	V_{SS} : Negative supply rail. Signal ground.
15	TX Mix: The output of the TX Mix Amplifier. Used with external components, it allows the TX Filter Out output to mix with externally generated signalling tones prior to the final level adjustment.
16	SAT Out: The output of the SAT Bandpass filter. This level is recovered from the input RX audio and is available for mixing externally with the transmitter modulation. See Figure 3.
17	TX Mix In: The input to the TX Mix Amplifier. Used with external components, it allows the TX Filter Out output to mix with externally generated signalling tones prior to the final level adjustment. The recovered SAT signal may be introduced at this point. See Figures 2 and 3.
18	TX Filter Out: The output of the Deviation Limiter/Lowpass Filter stage. This stage can be by-passed using SW3 (Configuration Command). See Figure 3.
19	No internal connection – Leave open circuit.
20	Deviation Limiter In: Input to the on-chip deviation limiter. This input should be a.c. coupled to the Pre-Emphasis Out pin. The a.c. coupling will achieve maximum possible symmetry of limiting as this input has a 1M Ω internal resistor to V_{BIAS} . See Figure 2.
21	Pre-Emphasis Out: Audio output from the TX Gain/Pre-Emphasis function. This output should be a.c. coupled to the Deviation Limiter In pin. See Figures 2 & 3.
22	DTMF In: To introduce DTMF type audio, at a suitable level for transmission, to the TX Path, controlled by SW2 (Configuration Command (10 _H)). This input has an internal 1M Ω resistor to V_{BIAS} and should be connected via a capacitor.
23	Compression In: The audio input from an external compression system. This input has an internal 1M Ω resistor to V_{BIAS} and should be connected via a capacitor.
24	Compression: The output to an external audio compression system. Currently available compressor/expanders have Op-Amps incorporated. The compressor can be by-passed by SW2.
25	Mic.2 In: TX voice (Mic.) inputs, selectable by SW1 available for handsfree mic./handset mic. or any TX audio input. Pre-amplification may be required at these inputs. These inputs
26	Mic.1 In: each have an internal 1M Ω resistor to V_{BIAS} and should be connected via a capacitor.
27	Play In: The input via SW2 from a voice storage device such as the MX812. This "replayed" audio can be sent to RX or TX paths allowing a Messaging/Voice Notepad/Answering facility. This input has an internal 1M Ω resistor to V_{BIAS} and should be connected via a capacitor.
28	V_{DD} : Positive supply rail. A single +5-volt power supply is required. Levels and voltages within this Audio Processor are dependent upon this supply.
<p><i>C-BUS is MX-COM's proprietary standard for the transmission of commands and data between a μController and the relevant Cellular microcircuits. It may be used with any μController, and can, if desired, take advantage of the hardware serial I/O functions embodied into many types of μController. The "C-BUS" data rate is determined solely by the μController.</i></p>	

Application Information

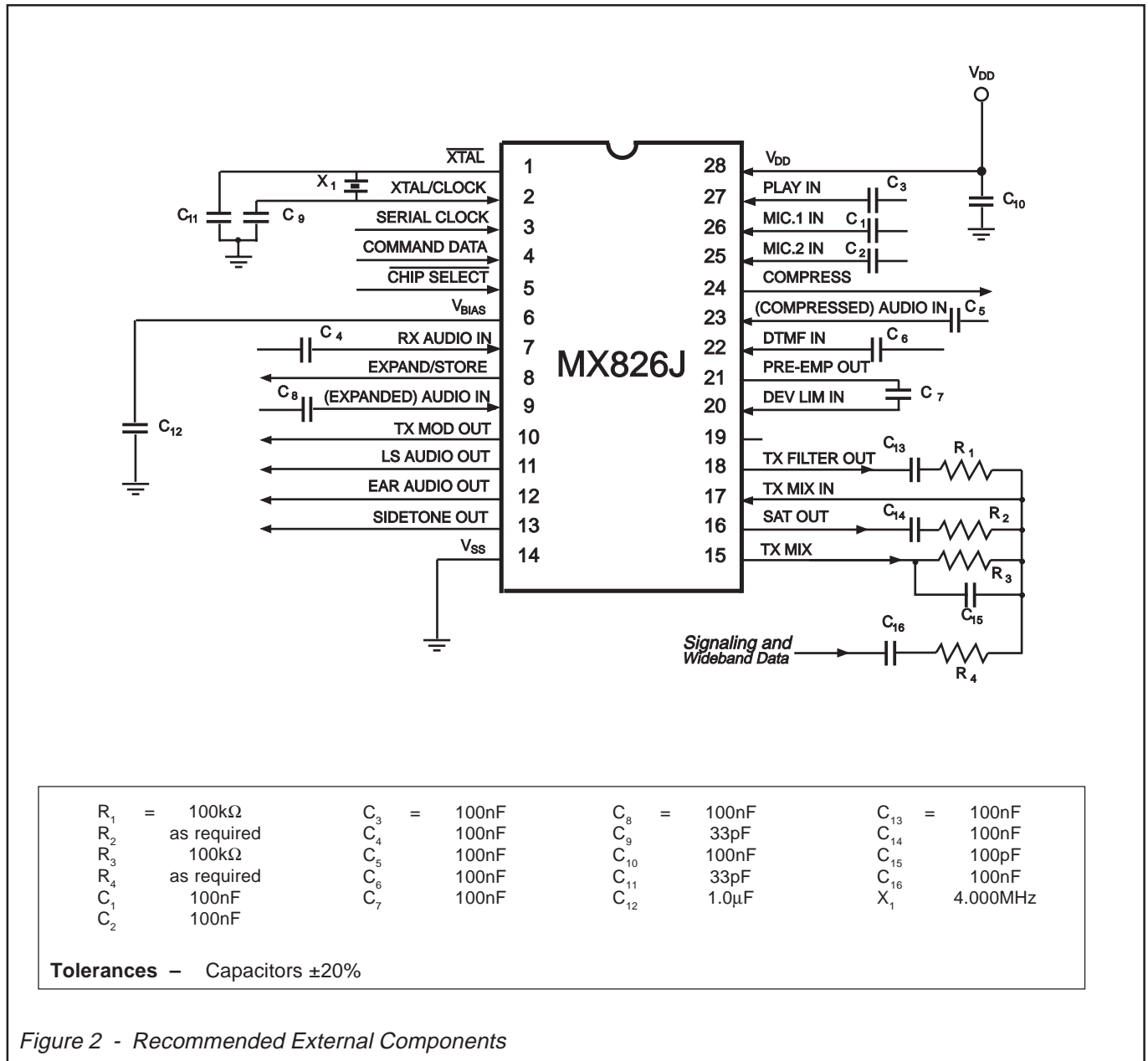

R ₁ = 100kΩ	C ₃ = 100nF	C ₈ = 100nF	C ₁₃ = 100nF
R ₂ as required	C ₄ = 100nF	C ₉ = 33pF	C ₁₄ = 100nF
R ₃ = 100kΩ	C ₅ = 100nF	C ₁₀ = 100nF	C ₁₅ = 100pF
R ₄ as required	C ₆ = 100nF	C ₁₁ = 33pF	C ₁₆ = 100nF
C ₁ = 100nF	C ₇ = 100nF	C ₁₂ = 1.0μF	X ₁ = 4.000MHz
C ₂ = 100nF			

Tolerances – Capacitors ±20%

Figure 2 - Recommended External Components

Notes

- Xtal/clock operation**
 Operation of any MX-COM IC without a Xtal or clock input may cause device damage. To minimize damage in the event of a Xtal/drive failure, you should install a current limiting device (resistor or fast-reaction fuse) on the power input (V_{DD}).
- SAT Output**
 It is possible, due to the impedance of this output, that an external buffer amplifier will be required when interfacing or mixing with other cellular system sections.
- TX Mix Gain**
 The value of R₄ should be chosen with R₃/C₁₅ in order to provide the required gain.

AMPS/NAMPS Cellular System Interfaces

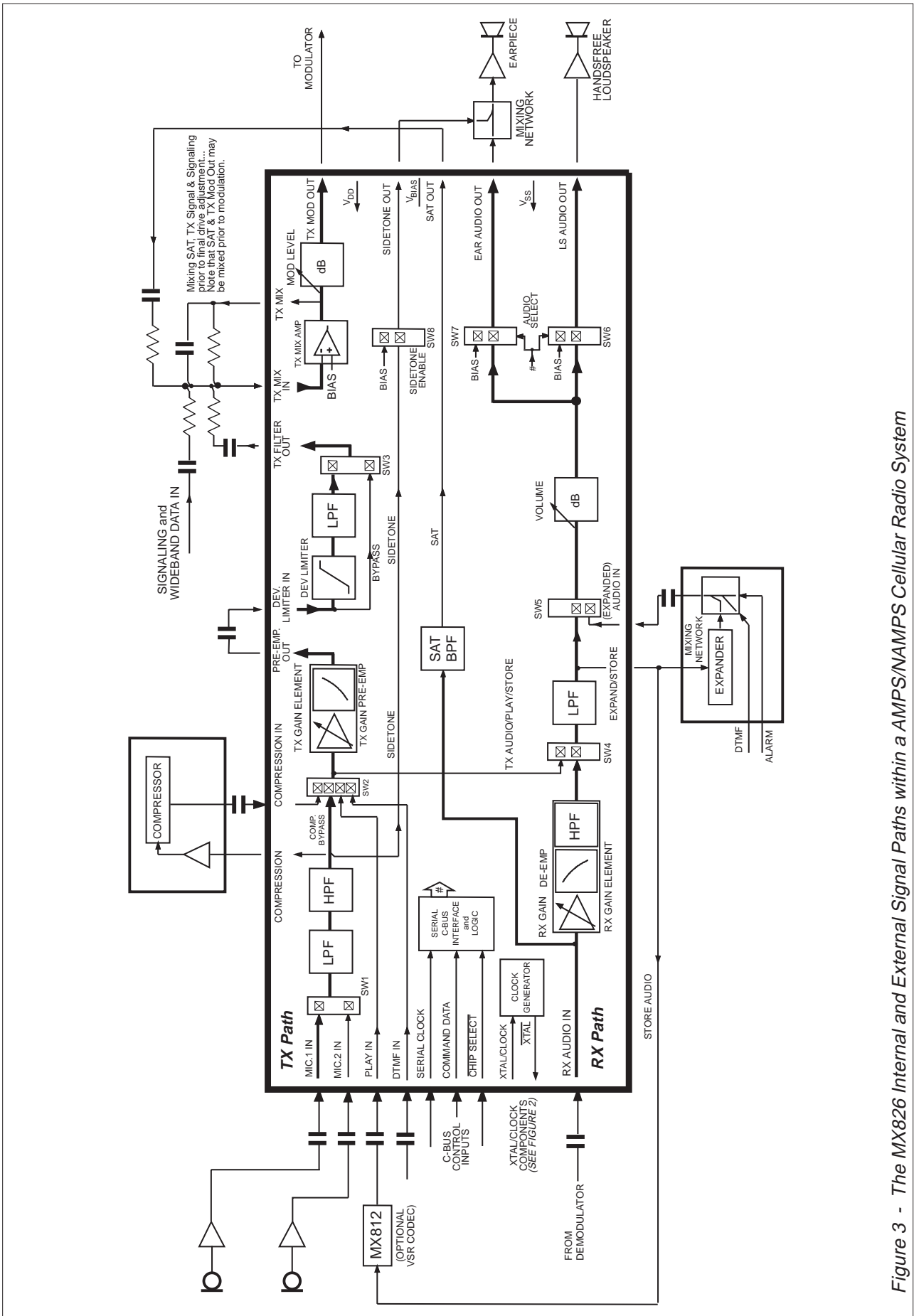

Figure 3 - The MX826 Internal and External Signal Paths within a AMPS/NAMPS Cellular Radio System

The Controlling System: C-BUS Hardware Interface

C-BUS is MX-COM's proprietary standard for the transmission of commands and data between a μ Controller and MX-COM's New Generation integrated circuits. C-BUS has been designed for a low IC pin-count, flexibility in handling variable amounts of data, and simplicity of system design and μ Controller software.

It may be used with any μ Controller, and can, if desired, take advantage of the hardware serial I/O functions built into many types of μ Controller. Because of this flexibility and because the BUS data-rate is determined solely by the μ Controller, the system designer has complete freedom to choose a μ Controller appropriate to the overall system processing requirements.

Control of the functions and levels within the MX826 is by a group of Address/Commands and appended data instructions from the system μ Controller to set/adjust the functions and elements of the device. The use of these instructions is detailed in the following paragraphs and tables.

Command Assignment	Address/Command (A/C) Byte				Command Data	Table
	Hex	MSB	Binary	LSB		
General Reset	01	0	0 0 0 0 0 0 0 1			
Configuration Command	10	0	0 0 0 1 0 0 0 0	+	1 byte	2
TX Gain & Mod. Command	11	0	0 0 0 1 0 0 0 1	+	1 byte	3
RX Gain & Vol. Command	12	0	0 0 0 1 0 0 1 0	+	1 byte	4
Powersave Command	13	0	0 0 0 1 0 0 1 1	+	1 byte	5

Table 1 "C-Bus" Address/Commands

In C-BUS protocol the audio processor is allocated Address/Command (A/C) values 10_H to 13_H. Configuration, TX/RX Gains, Powersave assignments and data requirements are given in Table 1. Each instruction consists of an Address/Command (A/C) byte followed by a data instruction formulated from the following tables.

Commands and Data are only to be loaded in the group configurations detailed, as the C-BUS interface recognizes the

first byte after Chip Select (logic "0") as an Address/Command. Function or Level control data, which is detailed in Tables 2, 3, 4 and 5, is acted upon at the end of the loaded instruction. See Timing Diagrams, Figures 5 and 6.

Upon Power-Up the value of the "bits" in this device will be random (either "0" or "1"). A **General Reset Command (01_H)** will be required to set all MX826 registers to 00_H.

Configuration Command *(Preceded by A/C 10_H)*

Setting	Control Bits
MSB Bit 7	Transmitted First Sw8 Sidetone
0	Sidetone Bias
1	Sidetone Enabled
6	Sw6/7 RX Audio
0	Ear Enabled, LS Bias
1	LS Enabled, Ear Bias
5	Sw5 Expander
0	Expander By-Pass
1	Expander Route
4	Sw4 TX/RX Audio
0	Tx Store/Audio
1	Rx Store/Audio
3	Sw3 Dev. Limiter
0	Dev. Limiter Bypass
1	Dev. Limiter Route
2	Sw1 Mic. Inputs
0	Mic. 1 Input
1	Mic.2 Input
1 0	Sw2 TX Function
0 0	DTMF In
0 1	Compressor Bypass
1 0	Compressor In
1 1	Play In

Table 2 Configuration Commands

TX Gain & Mod. Command *(Preceded by A/C 11_H)*

Setting	Gain (dBs)
MSB	Transmitted First Tx Mod. Level
7 6 5 4	OFF (Low Z to V _{BIAS})
0 0 0 0	-5.6
0 0 0 1	-5.2
0 0 1 0	-4.8
0 0 1 1	-4.4
0 1 0 0	-4.0
0 1 0 1	-3.6
0 1 1 0	-3.2
0 1 1 1	-2.8
1 0 0 0	-2.4
1 0 0 1	-2.0
1 0 1 0	-1.6
1 0 1 1	-1.2
1 1 0 0	-0.8
1 1 0 1	-0.4
1 1 1 0	0
3 2 1 0	TX Input Gain
0 0 0 0	-2.65
0 0 0 1	-2.05
0 0 1 0	-1.50
0 0 1 1	-0.95
0 1 0 0	-0.45
0 1 0 1	0
0 1 1 0	0.45
0 1 1 1	0.85
1 0 0 0	1.25
1 0 0 1	1.65
1 0 1 0	2.05
1 0 1 1	2.40
1 1 0 0	2.70
1 1 0 1	3.05
1 1 1 0	3.35
1 1 1 1	3.65

Table 3 TX Gain & Mod. Commands

The Controlling System

RX Gain & Vol. Command *(Preceded by A/C 12_H)*

Setting				Gain (dBs)	
MSB				Transmitted First RX Volume OFF (Low Z to V _{BIAS})	
7	6	5	4		
0	0	0	0		-28.0
0	0	0	1		-26.0
0	0	1	0		-24.0
0	0	1	1		-22.0
0	1	0	0		-20.0
0	1	0	1		-18.0
0	1	1	0		-16.0
0	1	1	1		-14.0
1	0	0	0		-12.0
1	0	0	1		-10.0
1	0	1	0		-8.0
1	0	1	1		-6.0
1	1	0	0		-4.0
1	1	0	1		-2.0
1	1	1	0		0
1	1	1	1		
3					RX Input Gain
0	0	0	0		
0	0	0	1	4.30	
0	0	0	1	4.80	
0	0	1	1	5.30	
0	1	0	0	5.80	
0	1	0	1	6.20	
0	1	1	0	6.55	
0	1	1	1	7.05	
1	0	0	0	7.40	
1	0	0	1	7.80	
1	0	1	0	8.15	
1	0	1	1	8.50	
1	1	0	0	8.80	
1	1	0	1	9.10	
1	1	1	0	9.40	
1	1	1	1	9.70	

Table 4 - RX Gain and Vol. Commands

Powersave Command *(Preceded by A/C 13_H)*

Setting							Control Bits
MSB							Transmitted First
7	6	5	4	3	2	1	
0	0	0	0	0	0	0	All must be a logic "0"
0							Powersave Setting Powersave MX826 Enable MX826
1							

Table 5 - Powersave Command

Reference Signal Levels

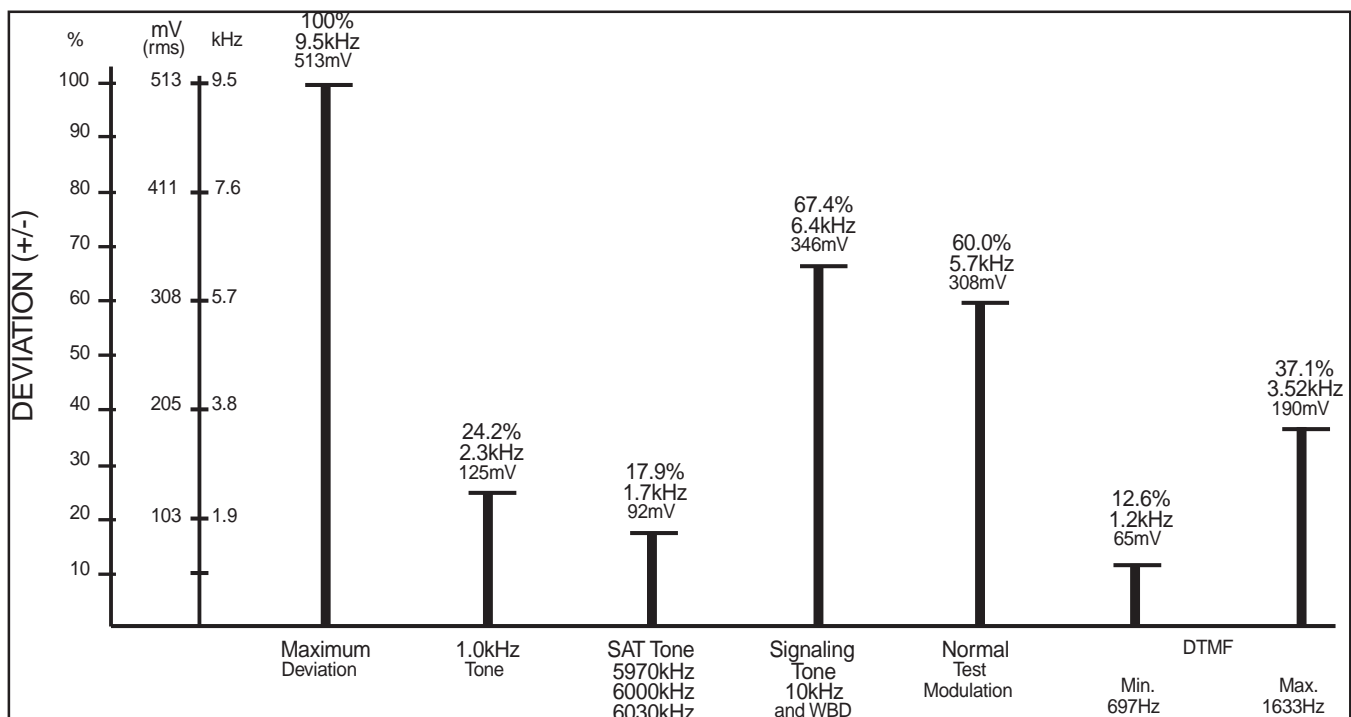

Figure 4 - Signal Deviation Levels and corresponding TX Mod Outputs with the Mod Level set to 0dB

Control Timing Information

Characteristics	See Note	Min.	Typ.	Max.	Unit
t_{CSE}	"CS-Enable to Clock-High"	1	2.0	—	μ s
t_{CSH}	Last "Clock-High to CS-High"	1	4.0	—	μ s
t_{CSOFF}	"CS-High" Time between transactions	1, 2	2.0	—	μ s
t_{CK}	"Clock-Cycle" Time	1	2.0	—	μ s
t_{NXT}	"Inter-Byte" Time	1	4.0	—	μ s
t_{CH}	"Serial Clock-High" Period		500	—	ns
t_{CL}	"Serial Clock-Low" Period		500	—	ns
t_{CDS}	"Command Data Set-Up" Time		250	—	ns
t_{CDH}	"Command Data Hold" Time		0	—	ns

Notes

1. These Minimum Timing values are altered during operation of the MX812 VSR Codec.
2. Chip Select must be taken to a logic "1" between each individual transaction.

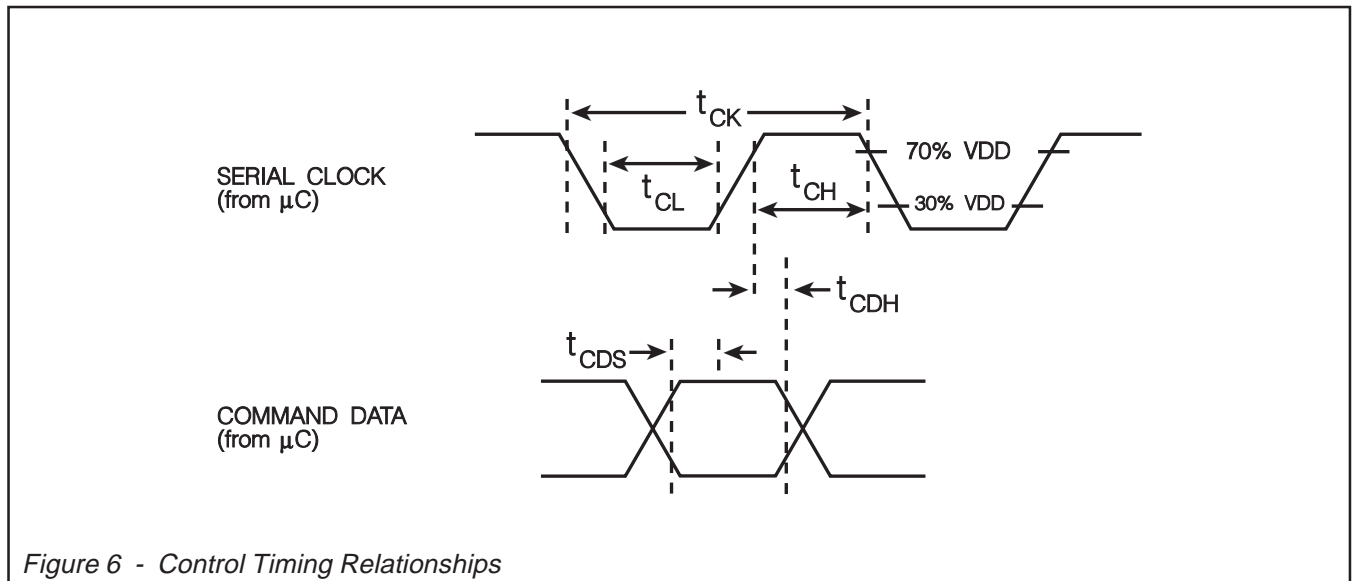
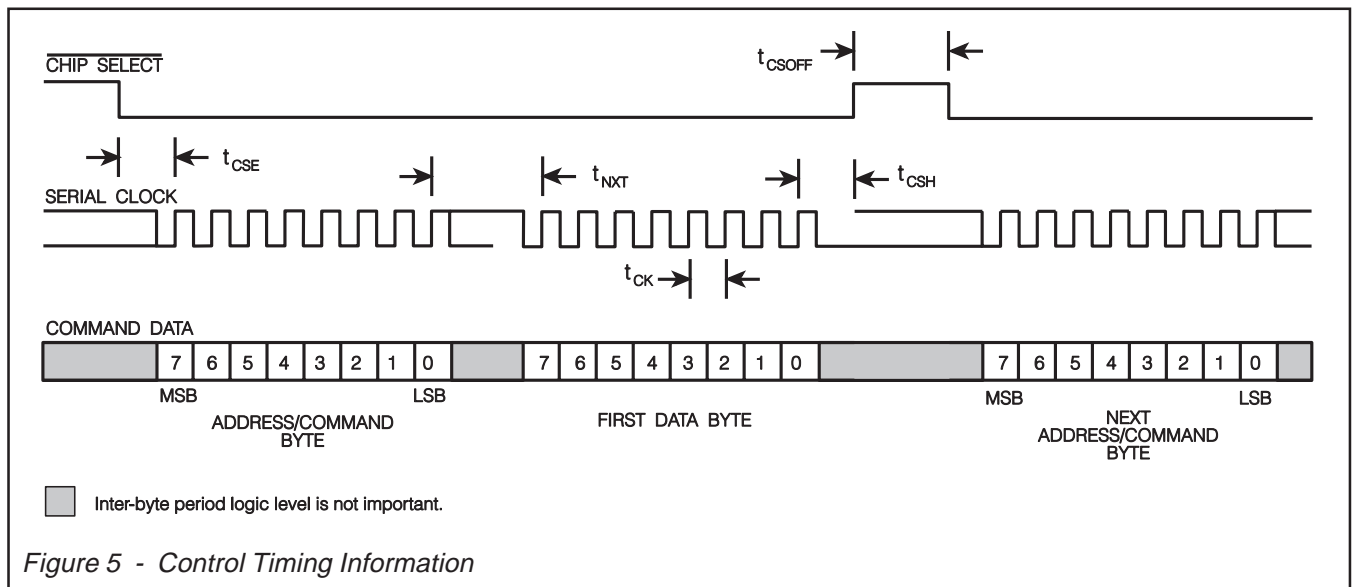

Frequency Responses

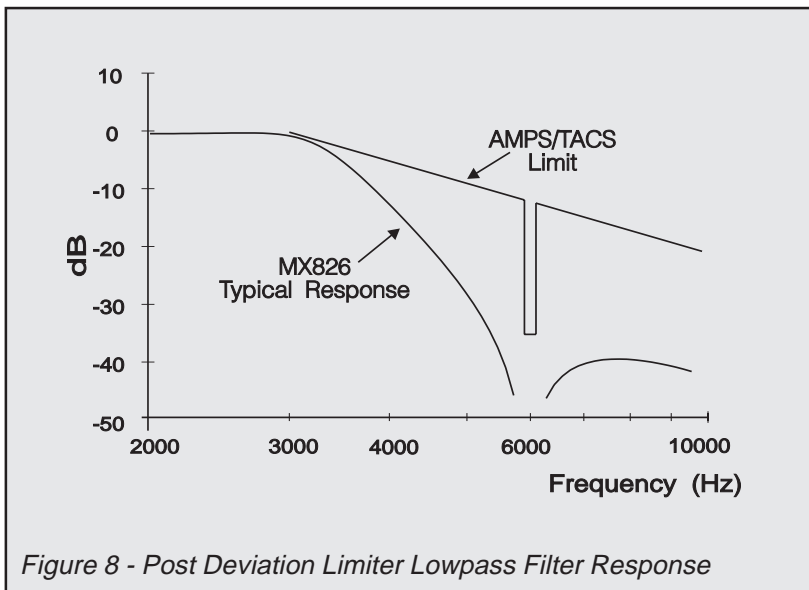
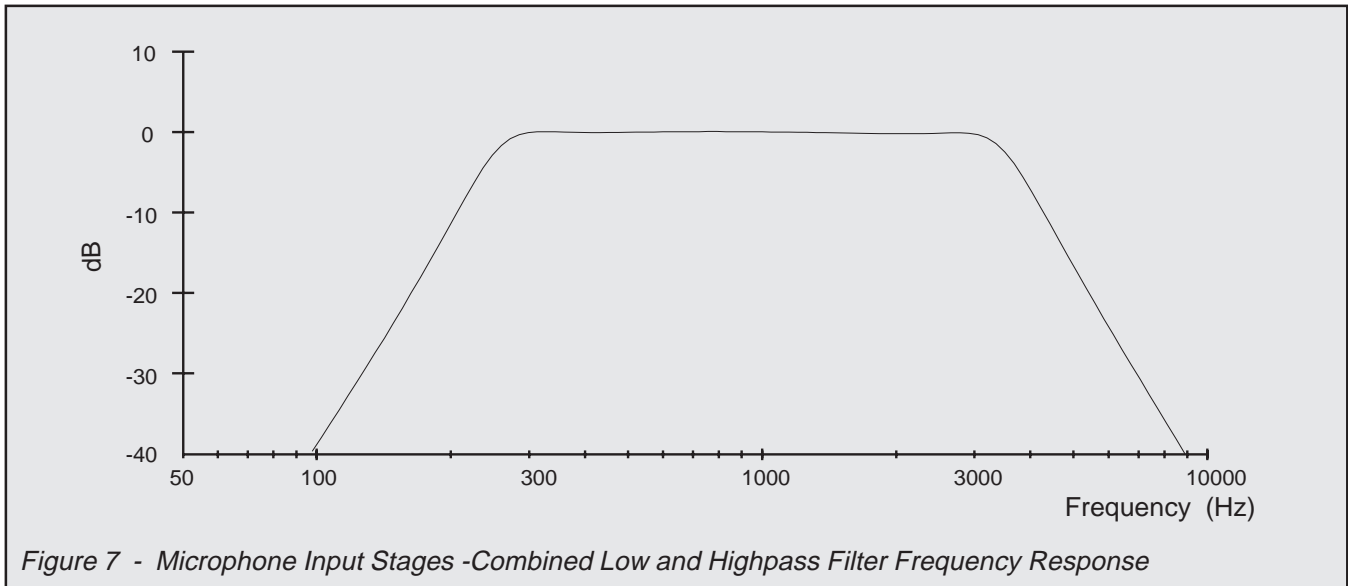

Figure 7
Mic.1/2 In to Compression Out

V_{DD} = 5.0V
Signal Input Level = 55.0mVrms

Figure 8
Dev Limiter In to TX Filter Out

V_{DD} = 5.0V
Signal Input Level = 55.0mVrms

Figure 9

RX Audio In to SAT out

V_{DD} = 5.0V
Signal Input Level = 100mVrms

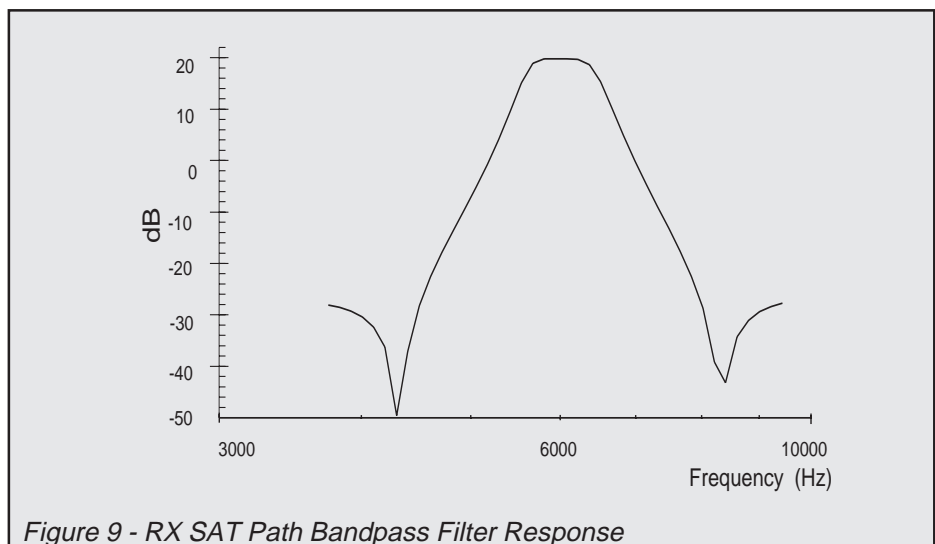

Specifications

Absolute Maximum Ratings

Exceeding the maximum rating can result in device damage. Operation of the device outside the operating limits is not suggested.

Supply Voltage	-0.3 to 7.0 V
Input Voltage at any pin (Ref $V_{SS} = 0V$)	-0.3V to ($V_{DD} + 0.3V$)
Sink/source Current (Supply pins)	±30mA
(Other pins)	±20mA
Total Device Dissipation @ $T_{AMB} 25^{\circ}C$	800mW max.
Derating	10mW/ $^{\circ}C$
Operating Temperature	-40 $^{\circ}C$ to +85 $^{\circ}C$
Storage Temperature	-55 $^{\circ}C$ to +125 $^{\circ}C$

Operating Limits

All devices were measured under the following conditions unless otherwise noted.

$$V_{DD} = 5.0V$$

$$T_{AMB} = 25^{\circ}C$$

$$\text{Xtal/clock } f_{XTAL} = 4.0MHz$$

$$\text{Audio level } 0dB \text{ ref.} = 308mV_{rms} @ 1kHz$$

Characteristics	See Note	Min.	Typ.	Max.	Unit
Static Values					
Supply Voltage		4.5	5.0	5.5	V
Supply Current					
Operating		–	6.5	–	mA
Powersave		–	0.5	–	mA
Alias Frequency		–	63.0	–	kHz
On-Chip Xtal Oscillator					
R_{IN}		10.0	–	–	M Ω
R_{OUT}		–	10.0	–	k Ω
Inverter d.c. Voltage Gain		–	10.0	–	V/V
Gain/Bandwidth Product		–	10.0	–	MHz
TX Mix Amp (Open Loop Gain)		–	50.0	–	dB
(Bandwidth)		20.0	–	–	kHz
Analog Input Impedances					
Mic.1 & 2		–	500	–	k Ω
Play		–	500	–	k Ω
Comp In		–	500	–	k Ω
DTMF In		–	500	–	k Ω
Dev. Limiter In		–	100	–	k Ω
(Expanded) Audio In		–	47.0	–	k Ω
TX Mix In		10.0	–	–	M Ω
RX Audio In		–	100	–	k Ω
Analog Output Impedances					
Pre-Emp Out		–	600	–	Ω
TX Mod Out		–	600	–	Ω
Expand/Store		–	600	–	Ω
LS and Ear Audio		–	1.0	–	k Ω
SAT Out	3	–	1.0	–	k Ω
TX Filter Out		–	600	–	Ω
Comp Out		–	600	–	Ω
Sidetone Out		–	2.0	–	k Ω
TX Mix (Open Loop)		–	6.0	–	k Ω
(Closed Loop)		–	600	–	Ω
Switches – ON		–	1.0	–	k Ω
– OFF		10.0	–	–	M Ω

Characteristics	See Note	Min.	Typ.	Max.	Unit
Control Interface Parameters					
Input Logic Levels					
Logic "1"	1	3.5	–	–	V
Logic "0"	1	–	–	1.5	V
I _{IN} (logic "1" or "0")	1	-1.0	–	1.0	μA
Input Capacitance	1	–	–	7.5	pF
Channel Performances					
TX Path					
Filter Specifications					
Pre-Compression L/HPF Combination					
Passband		300		3000	Hz
Slope - below 300Hz		+24.0	–	–	dB/oct.
above 3000Hz		-24.0	–	–	dB/oct.
TX Gain Pre-Emphasis					
Gain at 1.0kHz		–	0	–	dB
Slope (300Hz - 3000Hz)		–	6.0	–	dB/oct.
Post Deviation Limiter LPF					
Attenuation Relative to 1.0kHz					
3.0kHz - 5.9kHz		-	40 log(f/3000)	-	dB
5.9kHz - 6.1kHz		-	35.0	-	dB
6.1kHz - 15kHz		-	40 log(f/3000)	-	dB
>15kHz		-	28.0	-	dB
Analog Signal Input Levels					
Mic. 1 and 2	2	–	0	–	dB
Play	2	–	0	–	dB
DTMF	2	–	0	–	dB
Comp. In	2	–	0	–	dB
TX Mix In	2	–	0	–	dB
Analog Signal Output Levels					
Pre-Emp Out	2	–	0	–	dB
TX Filter Out	2	–	0	–	dB
TX Mod Out	2	–	0	–	dB
Sidetone Out	2	–	0	–	dB
Path Gains/Levels					
TX Gain – 11_H					
Nominal Adjustment Range		-2.65	–	3.65	dB
Error of any Setting		-0.2	–	0.2	dB
Dev Limiter					
Threshold		–	1086	–	mVp-p
Symmetry		–	7.0	–	%
Mod Level Attenuation – 11_H					
Nominal Adjustment Range		-5.6		0	dB
Step Size		0.2	0.4	0.6	dB
Error of any Setting		-1.0	–	1.0	dB
Overall					
TX Distortion		–	-40.0	-32.0	dBp
TX Hum and Noise		–	-40.0	-20.0	dB
RX Signal Path					
Filter Specifications					
RX Gain De-Emphasis					
Gain at 1.0kHz		–	3.75	–	dB
Slope (300Hz - 3000Hz)		–	-6.0	–	dB/oct.
RX Channel Bandpass					
Passband		300		3000	Hz
Slope - below 300Hz		+24.0	–	–	dB/oct.
above 3000Hz		-36.0	–	–	dB/oct.

Characteristics	See Note	Min.	Typ.	Max.	Unit
RX Signal Path (cont'd)					
Analog Signal Levels					
RX Audio Input Level	2	–	-7.0	–	dB
LS/Ear Audio Output Level	2	–	0	–	dB
Path Gains/Levels					
RX Gain – 12_H					
Nominal Adjustment Range		3.75		9.70	dB
Error of any Setting		-0.2	–	0.2	dB
Volume – 12_H					
Nominal Adjustment Range		-28.0		0	dB
Step Size		1.5	2.0	2.5	dB
Error of any Setting		-1.0	–	1.0	dB
Overall					
RX Distortion		–	-40.0	-32.0	dBp
RX Hum and Noise		–	-40.0	-34.0	dB
SAT Signal Path					
Bandpass Filter					
Frequency Range		5970		6030	Hz
Gain		19.0	20.0	21.0	dB

Notes

- Serial Clock, Command Data and Chip Select inputs.
- Levels equivalent to ± 3.0 kHz deviation with the settings below:
TX Gain = 0dB *Mod Level = 0dB*
RX Gain = 7.05dB *Volume = 0dB*
 Other levels can be achieved by adjusting the above variable gain blocks in accordance with Tables 1 to 5.
- Recommended load $>10.0k\Omega$.

Package Outline

The MX826 packages available are shown below. Pin 1 is marked with an indent spot. Pins on both package styles number counter-clockwise when viewed from the top (marked side).

Handling Precautions

The MX826 is a CMOS LSI circuit which includes input protection. However precautions should be taken to prevent static discharges which may cause damage.

Fig.10 MX826DW 28-pin Small Outline I.C. Package

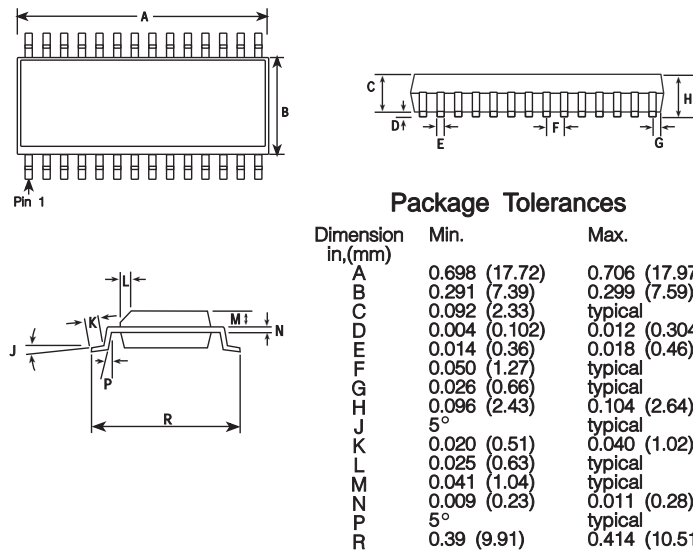

Fig.11 MX826J 28-pin Ceramic Dual In-Line Package

