



MX93521

ALL DIGITAL VOICE RECORDER MACHINE BASED ON THE MX93521 VOCODER CHIP

1. FEATURES

- Excellent sound quality by adopting 4800bps CELP speech compression algorithm.
- Silent Compression algorithm to further compress silence between speech.
- Flash Memory Management algorithm to manage down-graded Flash Memory to store compressed speech data. With silent compression, one 4Mbit flash memory could store up to 18 minutes speech.
- Support 4/8/16/32 Mbit Samsung Flash Memory or its compatible parts
- Support both parallel and serial microprocessor interface.
- Codec Interface circuit (support both TP3054 and MX93000)
- Host controllable LCD Module Interface
- Host writable message header (4 bytes) for identification or index purpose
- Powerful Editing Function
- Varieties of operating function including Rewind, Fast Forward, Repeat and message editing etc.
- Voice activated recording
- Use Flash memory to store user data (data bank)
- Upload/Download speech message data from/to HOST
- VOCODER mode (VOICE COMPRESSOR/ DECOMPRESSOR)
- Direct CODEC Play Mode (Play PCM/u-Law data received from HOST)
- Play Voice Prompt from ROM/FLASH memory
- DTMF tone generator

2. GENERAL DESCRIPTION

This document describes how to implement an all-digital voice recorder using the MX93521 chip. The MX93521 is a Digital Recorder Data Pump which is controlled by an external microprocessor to perform various recorder function.

The MX93521 is fully controlled by a HOST controller through a simple HOST interface protocol. The HOST could initiate many digital recording functions such as record, play, repeat, search, skip, insertion, message managing and self-diagnosis. Also, HOST could set MX93521 in VOCODER mode and use MX93521 as a speech compression/decompression data pump. The functions supported by MX93521 are listed as followed.

MODE	FUNCTION PATH
RECORD	CODEC-->(COMPRESS)-->FLASH
PLAY	CODEC-->(DECOMPRESS)<--FLASH
RECORD (VOCODER)	CODEC-->(COMPRESS)-->HOST
PLAY (VOCODER)	CODEC-->(DECOMPRESS)<--HOST
DIRECT CODEC PLAY MODE	CODEC-->(PCM/u-Law)<--HOST
DOWNLOAD MESSAGE	FLASH(MSG)-->HOST
UPLOAD MESSAGE	FLASH(MSG)<--HOST
DATABANK ACCESS	FLASH(DATA)<-->HOST



3. PIN CONFIGURATIONS

3.1 Pinout Assignments for MX93521 100-Pin PQFP (Parallel Mode)

100-LQFP PIN ASSIGNMENT_iG

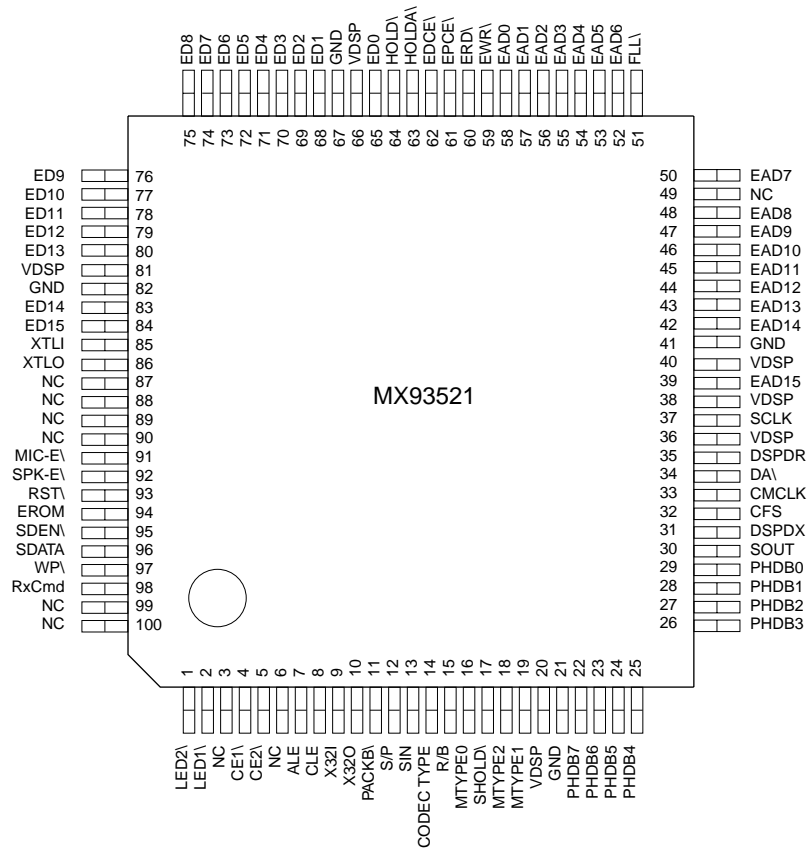



MX93521

100-PQFP PIN ASSIGNMENT_{iG}

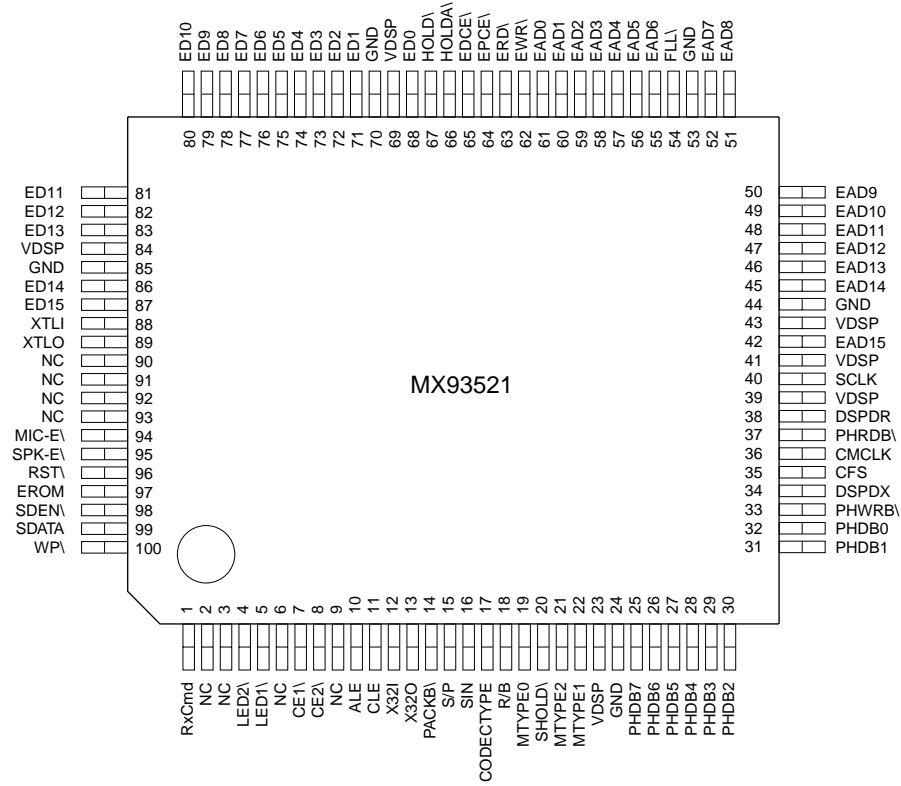

3.2 Pinout Assignments for MX93521 100-Pin TQFP (Serial Mode)

100-LQFP PIN ASSIGNMENT_iG

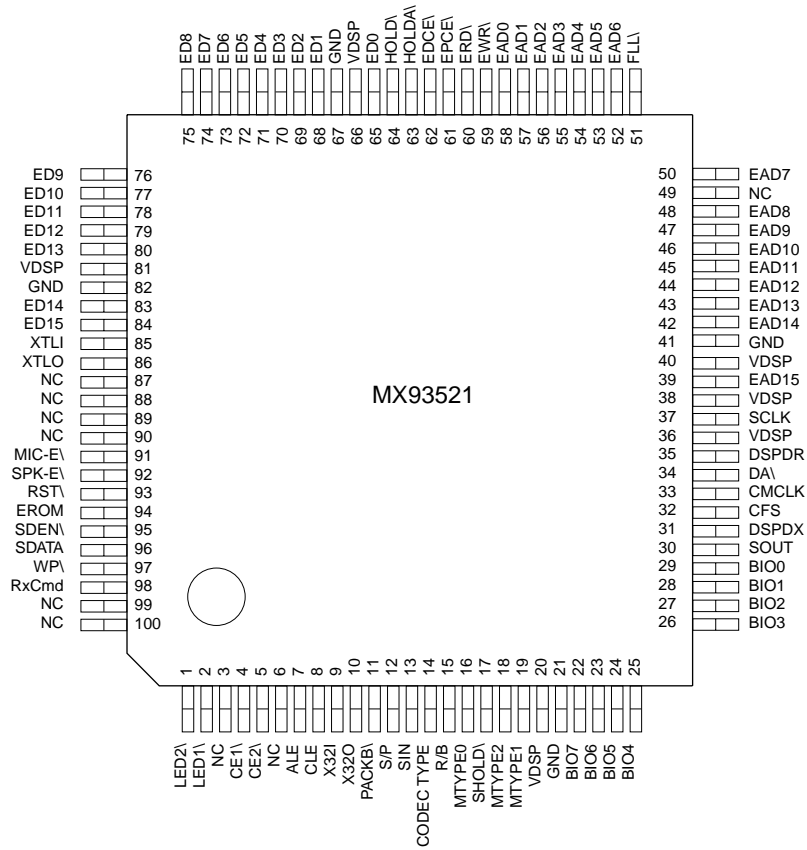



MX93521

100-PQFP PIN ASSIGNMENT_{iG}

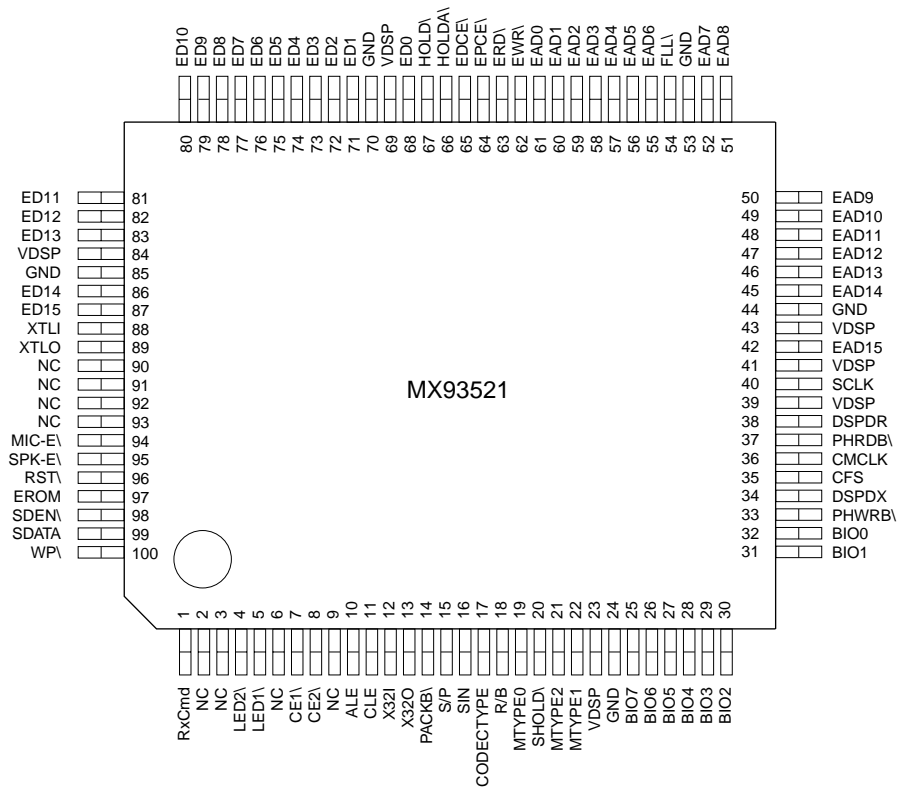



4. PIN DESCRIPTION

4.1 DSP BASIC (22 PINS)

SYMBOL	TYPE	PIN # (PQFP)	PIN # (LQFP)	DESCRIPTION
VDSP		23,43,69,84,41,39	20,40,66,81,38,36	5V power source
GND		24,44,53,70,85	21,41,67,82	Ground
FLL\	I	54	51	FLL\ low to set MX93521 running from single low crystal
XTLI		88	85	32.256Mhz Crystal input
XTLO		89	86	32.256Mhz Crystal output
RST\	I	96	93	Power on Reset, Schmite triggered
PACKB\	OA	14	11	In serial mode, PACKB\ is N.C. In parallel mode, PACKB\ becomes low when MX93521 write data to BIO and high when HOST read from BIO.
HOLD\	I	67	64	Hold DSP clock down and release bus
HOLDA\	OA	66	63	Ack to HOLD\ signal
EROM	I	97	94	Disable internal ROM, use external ROM only
SCLK	I	40	37	Transmit/receive data clock
X32O	OA	13	10	32.768Khz Crystal output
X32I		12	9	32.768Khz Crystal input

4.2 DSP EXTERNAL MEMORY(40 pins)

SYMBOL	TYPE	PIN # (PQFP)	PIN # (LQFP)	DESCRIPTION
EAD0-EAD15	OB	61~55,52~45,42	58~52,50,48~42,39	Address Bus
ED0~ED15	I/OB	68,71~83,86~87	65,68~80,83~84	Data Bus
EDCE\	OB	65	62	External data chip enable
EPCE\	OB	64	61	Reserved for future use
ERD\	OB	63	60	Flash external read
EWR\	OB	62	59	Flash external write
NC		90~93	87~90	No connection

4.3 uP INTERFACE(10 pins)

4.3.1 Serial Interface:(UPMODX=1)

SYMBOL	TYPE	PIN # (PQFP)	PIN # (LQFP)	DESCRIPTION
DA\	OC	37	34	Data Available (Output port OPT17)
SOUT	OC	33	30	Serial Data Out (Output port OPT16)
BIO(7..0)	OB	25~32	22~29	Drive LCD Display

**4.3.2 Parallel Interface:(UPMODX=0)**

SYMBOL	TYPE	PIN # (PQFP)	PIN # (LQFP)	DESCRIPTION
PHRDB\	I	37	34	Host read
PHWRB\	I	33	30	Host write
PHDB(7:0)	B	25~32	22~29	Host data bus

4.4 CODEC (4 pins)

SYMBOL	TYPE	PIN # (PQFP)	PIN # (LQFP)	DESCRIPTION
CFS	OB	35	32	Codec frame sync, 8Khz
CMCLK	OB	36	33	Codec master clock, 1.536Mhz
DSPDX	OA	34	31	Codec data transmit
DSPDR	I	38	35	Codec data receive

4.5 OPT:OUT PORT(16 pins)

SYMBOL	TYPE	PIN # (PQFP)	PIN # (LQFP)	DESCRIPTION
CLE	OC	11	8	Flash memory command latch enable
ALE	OC	10	7	Flash memory address latch enable
N.C.		6,9	3,6	
CE2\	OC	8	5	Chip enable 2
CE1\	OC	7	4	Chip enable 1
LED1\	OC	5	2	LED1 enable
LED2\	OC	4	1	LED2 enable
N.C. ^{DR-V5}		2,3		
RxCmd ^{DR-V5}	OC	1	98	Received Command (toggle when received command from HOST)
WP\	OC	100	97	Flash memory write protection
SDATA	OC	99	96	Serial data transfer (for MX93000)
SDEN\	OC	98	95	Serial data enable (for MX93000)
SPK-E	OC	95	92	Speaker enable,Hi-active
MIC-E\	OC	94	91	Microphone enable



4.6 IPT:INPUT PORT(8 pins)

SYMBOL	TYPE	PIN # (PQFP)	PIN # (LQFP)	DESCRIPTION
MTYPE1	I	22	19	Memory type select 1
MTYPE2	I	21	18	Memory type select 2
SHOLD\	I	20	17	Power down detect
MTYPE0	I	19	16	Memory type select 0
R/B	I	18	15	Flash memory Ready/Busy
CODECTYPE	I	17	14	Codec select (TP3054B or MX93000)
SIN	I	16	13	Serial data input
S/P\	I	15	12	Serial/parallel interface

NOTE:OA:2mA,OB:4mA,OC:16mA output current

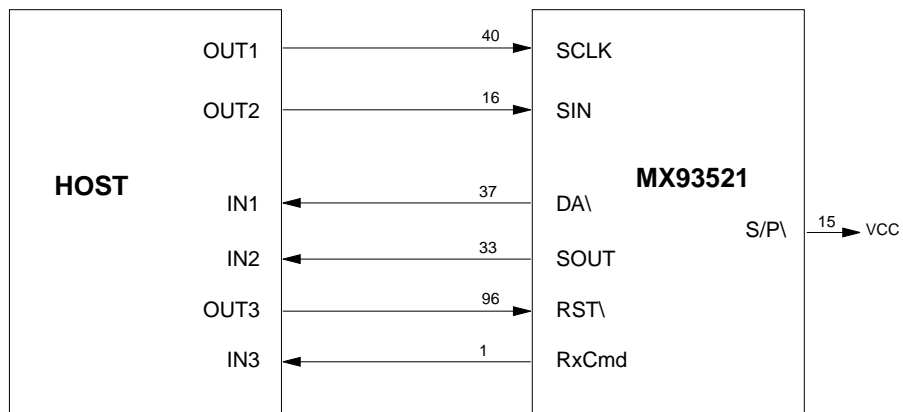
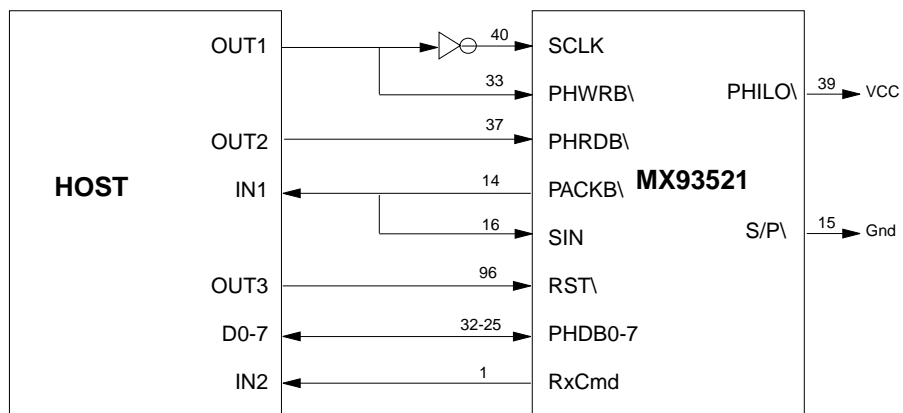
5. HOST CONTROLLER INTERFACE
5.1 HOST CONTROLLER INTERFACE
5.1.1 Configuration

SERIAL MODE

PARALLEL MODE

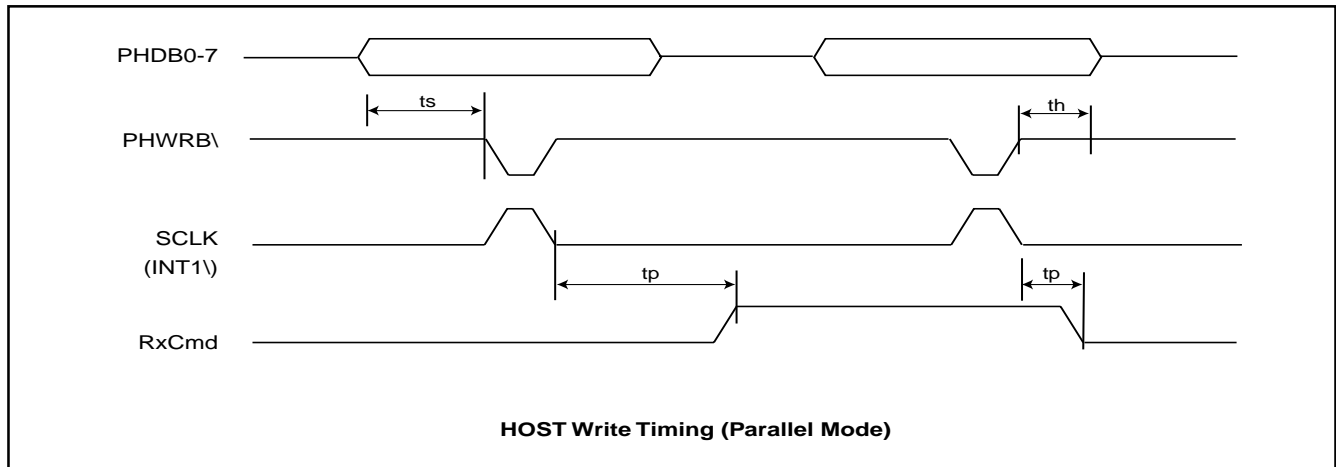
5.1.2 Timing Diagrams

HOST Write Timing (Parallel Mode)



HOST should cycle PHWRB\ after writing data to PHDB0-7.
 MX93521 will read data from PHDB0-7 on the falling edge of SCLK (rising edge of PHWRB\).
 Rxcmd will be toggled if command byte has been processed by MX93521

The PHWRB\ signal will cause MX93521 to latch data from bus PHDB0-7 to MX93521 internal register. The inverted signal of PHWRB\ will trigger MX93521 INT1\ to read and process the received data byte from internal register. Due to the interrupt contention, there might be an up to 50 us delay between the rising edge of PHWRB\ and INT1\ actually being served. To keep from command overrun, HOST should check if RxCmd toggled or wait 50 usec before sending next command byte to MX93521.

HOST Read Timing (Parallel Mode)

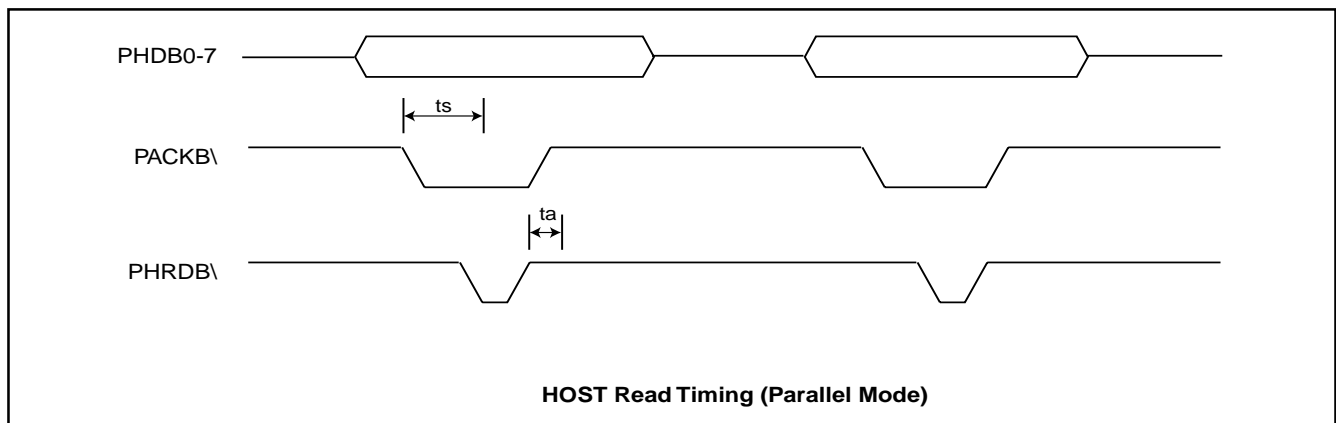

When MX93521 write data to PHDB0-7, PACKB\ will become low. HOST needs to poll the status of PACKB\ continuously. When HOST detect low state on PACKB\, HOST should read out data from PHDB0-7. After HOST read the data from PHDB0-7, PACKB\ will be reset to high.

The maxima delay between MX93521 write data to PHDB0-7 and PACKB\ become low is 10 ns.

The maxima delay between rising edge of PHRDB\ and PACKB\ become high is also 10 ns.

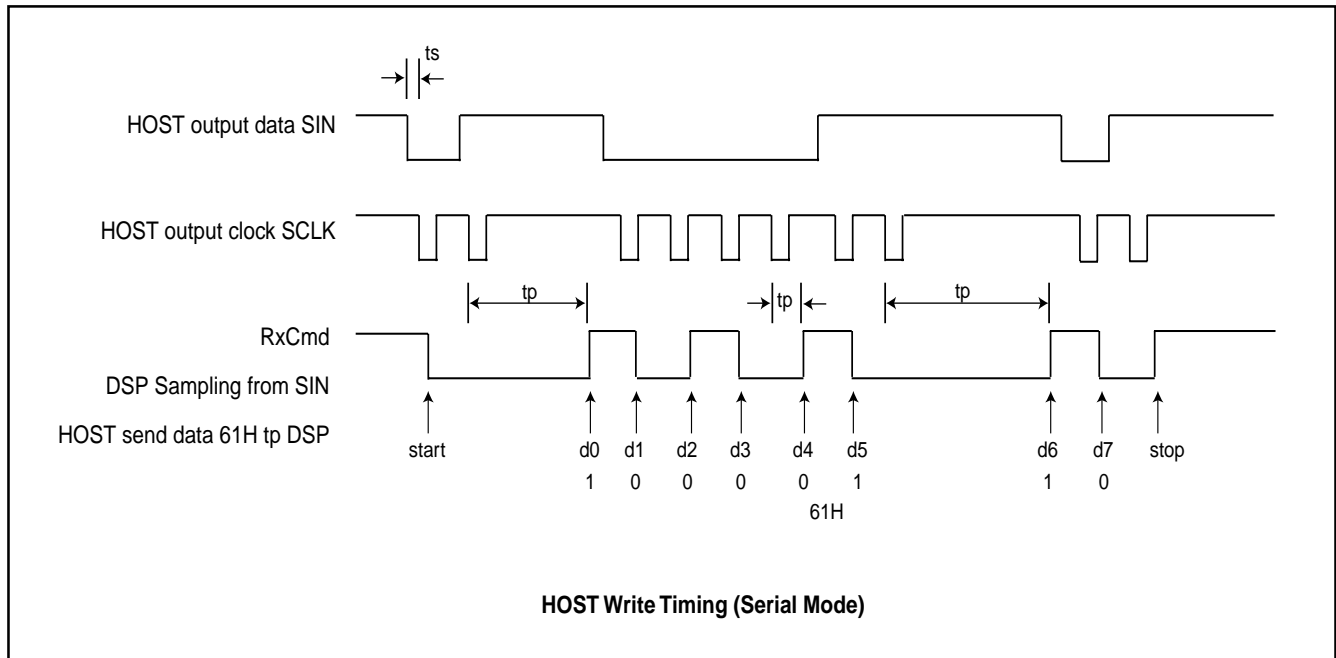
HOST Write Timing (Serial Mode)

RxCmd become low when start bit is received from HOST and toggle state when MX93521 received each following data bit or stop bit from HOST. Thus, instead of waiting for a fixed period of time (50us) to send a command bit, HOST could send the following command bit as soon as RxCmd toggled from previous state. The delay between the falling edge of SCLK and the RxCmd toggling time is range from 1 us to 50 us

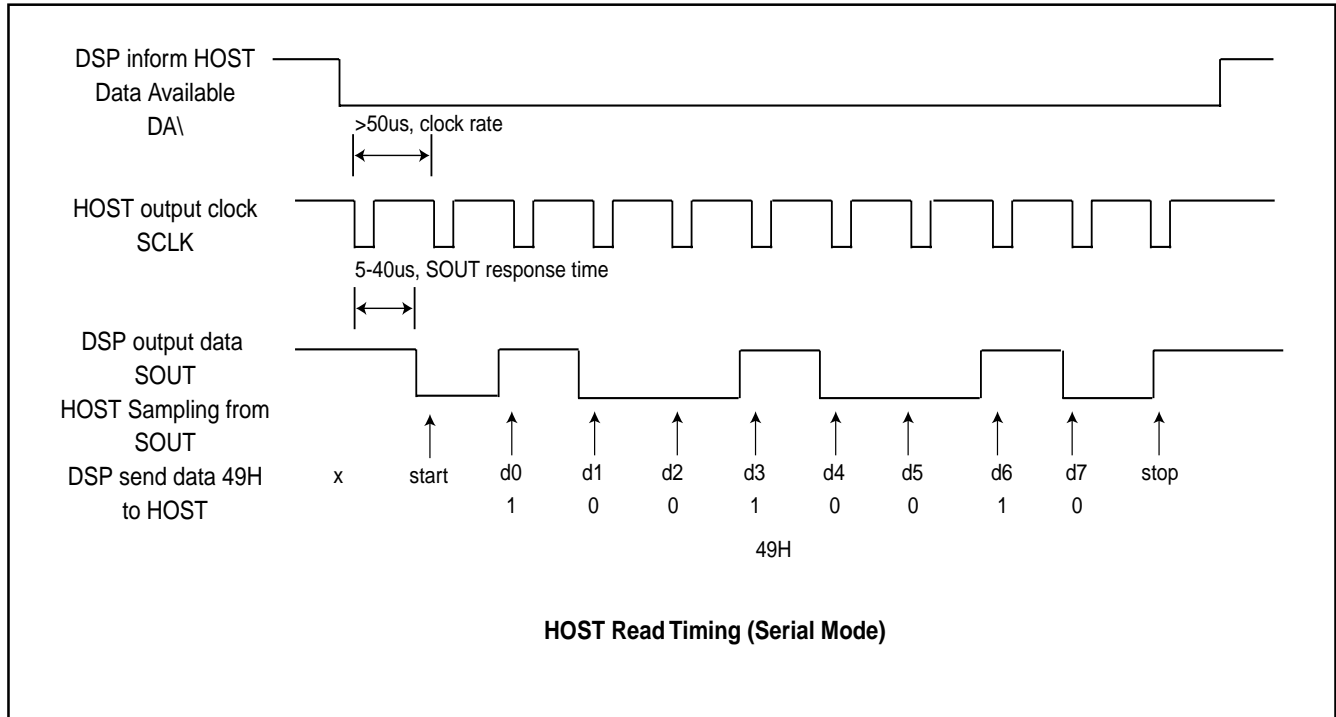
HOST Read Timing (Serial Mode)

SOUT response time is 5-40us from the falling edge of SCLK
 It is recommended that HOST sample SOUT right before the falling edge of SCLK

uP Interface Timing:

	Min	Max
Data setup time (ts)	10ns	
Data hold time (th)	2ns	
Data process time (tp)	1us	50us
PACKB\ acknowledge time (ta)		5ns



5.2 MX93521 IO INTERFACE

5.2.1 Output Port

		PIN		Power down state
LED1\	O	5	LED1 CONTROL	High
LED2\	O	4	LED2 CONTROL	High
UO0*	O	3	User Programmable Output Port	High
UO1*	O	2	User Programmable Output Port	High
UO2*	O	1	User Programmable Output Port	High

* User Programmable Output Port are only available in DR-V3 and DR-V4 version

5.2.2 Flash Memory Interface

MX93521		PIN	Flash	Power down state
MTYPE1	I	22	GND	0: SAMSUNG
MTYPE2	I	21	GND	0: SAMSUNG
MTYPE0	I	19	Vcc	(1:KM29N16000, 0:KM29N040)
CLE	O	11	CLE	Low
ALE	O	10	ALE	Low
ERD\	O	63	RD\	
CE2\	O	8	CE2\	High
CE1\	O	7	CE1\	High
EWR\	O	62	WR\	
R\B	I	18	R/B\	
WP\	O	100	WP\	Low
ED0	IO	68	IO0	
ED1	IO	71	IO1	
ED2	IO	72	IO2	
ED3	IO	73	IO3	
ED4	IO	74	IO4	
ED5	IO	75	IO5	
ED6	IO	76	IO6	
ED7	IO	77	IO7	

5.2.3 CODEC Interface

MX93521		PIN		Power down state
CODECTYPE	I	17	(1: MX93000, 0:TP3054)	
DSPDR	O	38		
DSPDX	O	34		
CFS	O	35		
CMCLK	O	36		
SDATA	O	99		High
SDEN\	O	98		High
SPK_E	O	95		Low
MIC_E\	O	94		High

5.2.4 uP Serial Mode Interface

MX93521		uP	LCD
RxCmd	O	IN3	(optional) MX93521 Rxd Command Indicator
S/P\	I	Vcc	High, Serial Mode
SCLK	I	OUT1	Serial Clock
DA\	O	IN1	Data Available
SOUT	O	IN2	Serial Data Output
SHOLD\	I	OUT3	DSP HOLD
SIN	I	OUT2	Serial Data Input
RST\	I	OUT4	DSP RESET
BIO2	O		E
BIO3	O		RS
BIO4	O		D4
BIO5	O		D5
BIO6	O		D6
BIO7	O		D7

5.2.5 uP Parallel Mode Interface

MX93521		uP	LCD
S/P\	I	GND	Low, Parallel Mode
SCLK	I	OUT1\	
PHRDB\	I	OUT2	Read
PHWRB\	I	OUT1	Write
SHOLD\	I	OUT3	DSP HOLD
RST\	I	OUT4	DSP RESET
PHILO\	I	Vcc	High, Byte Mode
SIN	I	IN1	SIN should be connected to PACKB\ externally
PACKB\	O	IN1	Acknowledge
RxCmd	O	IN2	(optional) MX93521 Rxd Command Indicator
PHDB0	I/O	D0	
PHDB1	I/O	D1	
PHDB2	I/O	D2	
PHDB3	I/O	D3	
PHDB4	I/O	D4	
PHDB5	I/O	D5	
PHDB6	I/O	D6	
PHDB7	I/O	D7	

When SHOLD\ is low, MX93521 will go to power down mode.

When SHOLD\ change from low to high, DSP will power up and send ACK0 to HOST



6. HOST INTERFACE SOFTWARE COMMAND SET SUMMARY

6.1 HOST TO MX93521 COMMANDS

When MX9521 received a command from HOST, it will always respond the command with a acknowledge. The valid commands and corresponded acknowledge are described as below.

D7	D6	D5	D4	D3	D2	D1	D0		
0	0	0	0	1	B	B	B	008H	POINT TO SPECIFIC MESSAGE
0	0	0	1	0	B	B	B	010H	GET CURRENT MESSAGE INFOMATION
0	0	0	1	1	B	B	B	018H	DELETE MESSAGE(S)
0	0	1	0	0	B	B	B	020H	REC/PLAY MISC. FUNCTION
0	0	1	0	1	B	B	B	028H	RECORD MESSAGE
0	0	1	1	0	B	B	B	030H	PLAY MESSAGE
0	0	1	1	1	B	B	B	038H	SKIP FORWARD/BACKWARD PLAY
0	1	0	0	0	B	B	B	040H	MISC. FUNCTION
0	1	0	0	1	B	B	B	048H	tone GENERATOR
0	1	0	1	1	B	B	B	058H	MX93000 CODEC MISC. FUNCTION
0	1	1	0	0	B	B	B	060H	LED DISPLAY
0	1	1	0	1	B	B	B	068H	WRITE COMPRESSED VOICE DATA TO MX93521
0	1	1	1	0	B	B	B	070H	LCD COMMAND
0	1	1	1	1	B	B	B	078H	LCD DATA
1	0	0	0	0	B	B	B	080H	OUTPUT COUNTER
1	0	0	0	1	B	B	B	088H	Download/Upload Message ^{DR-V5}
1	0	0	1	0	B	B	B	090H	Set Silence level ^{DR-V4}
1	0	0	1	1	B	B	B	098H	Set ROM/RAM wait state ^{DR-V5}
1	0	1	0	0	B	B	B	0A0H	Read/Write RAM ^{DR-V4}
1	0	1	0	1	B	B	B	0A8H	Read ROM ^{DR-V5}
1	0	1	1	x	B	B	B	0BxH	Data Bank Functions ^{DR-V4}
1	1	0	0	x	B	B	B	0CxH	Data Bank Functions ^{DR-V4}
1	1	0	1	0	B	B	B	0D0H	Data Bank Functions ^{DR-V4}
1	1	1	1	1	B	B	B	0F8H	Play Voice Prompt ^{DR-V4}

BBB:BYTES SEND FOLLOWING THIS COMMAND

MX93521 TO HOST ACKNOWLEDGES (OK Messages)

ACK0: 0A0H, NO DATA ACCOMPNIED THIS ACKNOWLEDGE

ACK1: 0A1H, 1 DATA ACCOMPNIED THIS ACKNOWLEDGE

ACK2: 0A2H, 2 DATA ACCOMPNIED THIS ACKNOWLEDGE

ACK6: 0A6H, 6 DATA ACCOMPNIED THIS ACKNOWLEDGE

MX93521 TO HOST ACKNOWLEDGES (ERROR Messgaes)

ERR0(0E0H): Command ERROR

ERR1(0E1H): Out of memory, MX93521 cannot perform RECORD function

ERR2(0E2H): No message found, MX93521 cannot perform PLAY function

ERR3(0E3H): No Flash Memory Detected when power on

ERR4(0E4H): MX93521 Busy

ERR5(0E5H): Vocoder Mode, Play buffer full, data rejected

ERR6(0E6H): No previous or next message found

ERR7(0E7H): MX93000 Command Busy

ERR8(0E8H): No empty block could be allocated for data bank usage ^{DR-V4}

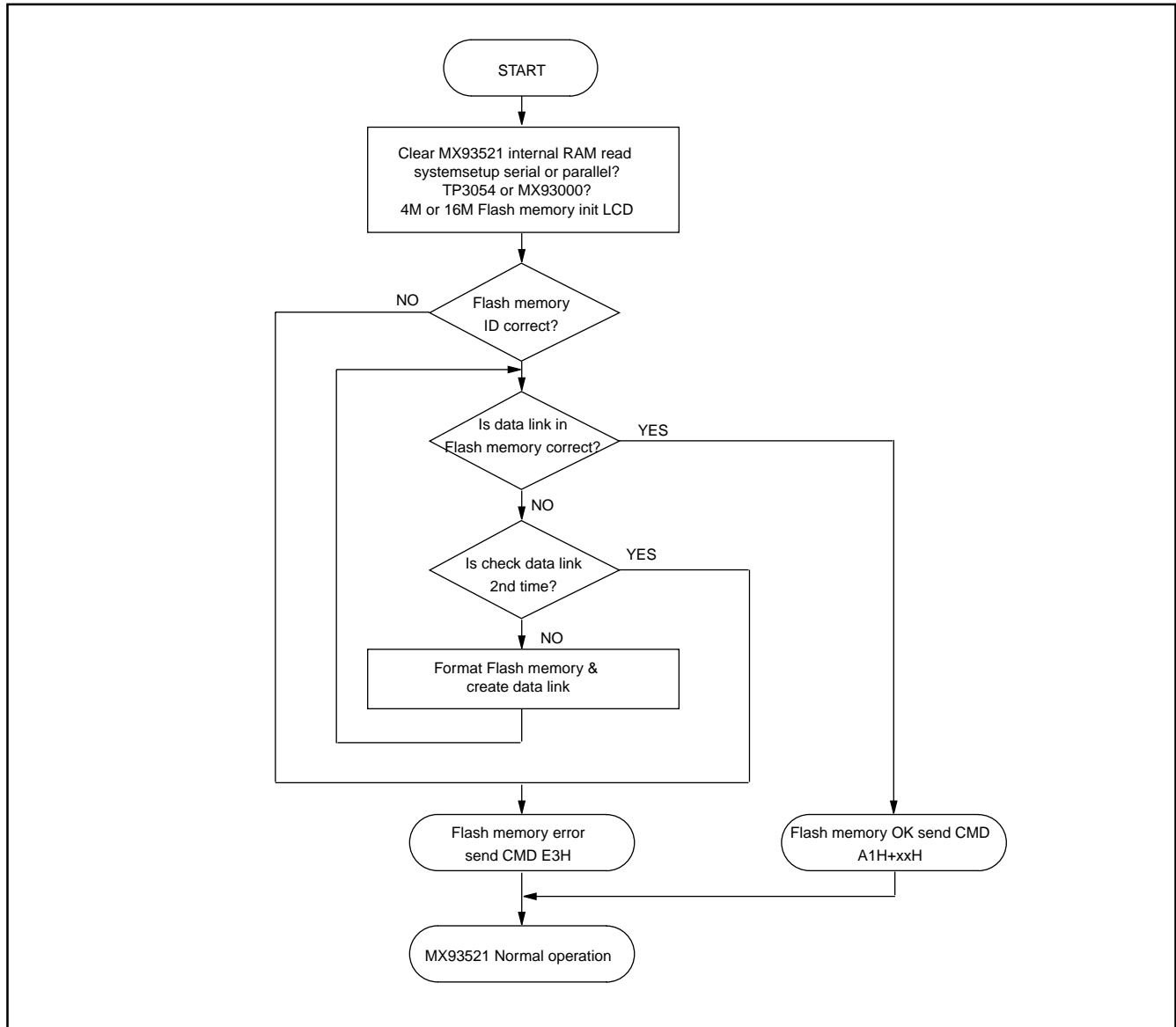
6.2 MX93521 Power On Initialization Flow Chart

0A1H+000H	DETECT SAMSUNG KM29N040 FLASH MEMORY
0A1H+001H	DETECT SAMSUNG KM29N16000 FLASH MEMORY
0A1H+002H	RESERVED
0A1H+003H	RESERVED
0A1H+004H	RESERVED
0A1H+005H	RESERVED
0A1H+006H	RESERVED
0A1H+007H	RESERVED
ERR3(0E3H)	NO MEMORY DETECTED

6.3 HOSTTO MX93521 COMMAND DESCRIPTIONS
COMMAND 09H

FUNCTION: Move Message Pointer
 RETURN: ACK0
 RETURN: ERR6, IF REACH THE FIRST OR THE LAST MESSAGE IN THE MEMORY

DB7	DB6	DB5	DB4	DB3	DB2	DB1	DB0
0	0	0	0	1	0	0	1
D	M	M	M	M	M	M	M

IF CURRENT MESSAGE NUMBER IS N, D=0, JUMP FORWARD M=001H, POINT TO THE MESSAGE (N+1) M=002H, POINT TO THE MESSAGE (N+2) M=07FH, POINT TO THE LAST MESSAGE	D=1, JUMP BACKWARD M=001H, POINT TO THE MESSAGE (N-1) M=002H, POINT TO THE MESSAGE (N-2) M=07FH, POINT TO THE FIRST MESSAGE
---	--

COMMAND 0AH^{DR-V5}

FUNCTION: Point to specific message
 RETURN: ACK0
 RETURN: ERR2, If no such message found in the FLASH memory

DB7	DB6	DB5	DB4	DB3	DB2	DB1	DB0	
0	0	0	0	1	0	1	0	
M	M	M	M	M	M	M	M	Message Number (High Byte)
M	M	M	M	M	M	M	M	Message Number (Low Byte)

*The message pointer is point to the last message in the flash memory upon power on.

SAMPLES:

Forward to the next message	09H	01H	
Rewind to the previous message	09H	81H	
Forward to the last message	09H	7FH	
Rewind to the the first message	09H	FFH	
Move Message Pointer to message #258 (102H)	0AH	01H	02H



COMMAND 10H

FUNCTION: GET CURRENT MESSAGE INFORMATION
RETURN: ACK6, DATA1, DATA2, DATA3, DATA4, DATA5, DATA6 or ACK0

DB7	DB6	DB5	DB4	DB3	DB2	DB1	DB0
0	0	0	1	0	0	0	0

DATA1: HIGH BYTE OF CURRENT MESSAGE NUMBER
DATA2: LOW BYTE OF CURRENT MESSAGE NUMBER
DATA3: USER DATA #1
DATA4: USER DATA #2
DATA5: USER DATA #3
DATA6: USER DATA #4

*RETURN ACK0 WHEN NO MESSAGE IN THE MEMORY

SAMPLES:

GET CURRENT MESSAGE INFORMATION	10H
---------------------------------	-----

- COMMAND 11H**
- COMMAND 12H**
- COMMAND 13H**
- COMMAND 14H**

FUNCTION: ATTACH USER DATA TO CURRENT MESSAGE
RETURN: ACK0 or ERR0

DB7	DB6	DB5	DB4	DB3	DB2	DB1	DB0
0	0	0	1	0	B	B	B
							USER DATA #1
							USER DATA #2
							USER DATA #3
							USER DATA #4

- * The USER DATA is default to 0FFH
- * Any data written with this command will be AND with previous data
- * When USER DATA #1 is 055H. If write data 0AAH to it again, USER DATA #1 will become 0H
- * If no message in the FLASH memory, MX93521 will return ERR0

SAMPLES:

ATTACH DATA 12H TO CURRENT MESSAGE	11H	12H		
ATTACH DATA 12H/34H TO CURRENT MESSAGE	12H	12H	34H	
ATTACH DATA 12H/34H/56H TO CURRENT MESSAGE	13H	12H	34H	56H
ATTACH DATA 12H/34H/56H/78H TO CURRENT MESSAGE	14H	12H	34H	56H 78H



COMMAND 19H

FUNCTION: DELETE MESSAGE(S)
RETURN: ACK0 after deletion completed

Table with 8 columns (DB7-DB0) and 3 rows showing bit patterns and mask values for the delete command.

IF CURRENT MESSAGE NUMBER IS N

D=0, DELETE FORWARD

M=001H, DELETE ONE MESSAGE AFTER MESSAGE #N (MSG #N WILL BE DELETED)

M=002H, DELETE TWO MESSAGES AFTER MESSAGE #N (MSG #N, #N+1 WILL BE DELETED)

M=07FH, DELETE ALL MESSAGES AFTER MESSAGE #N (MSG #N, #N+1,..., #LAST WILL BE DELETED)

D=1, DELETE BACKWARD

M=001H, DELETE ONE MESSAGE BEFORE MESSAGE #N (MSG #N WILL BE DELETED)

M=002H, DELETE TWO MESSAGES BEFORE MESSAGE #N (MSG #N, #N-1 WILL BE DELETED)

M=07FH, DELETE ALL MESSAGES BEFORE MESSAGE #N (MSG #N, #N-1,..., #1 WILL BE DELETED)

SAMPLES:

Table with 3 columns: Command description, Hex value, and Mask value. Rows include delete current message, delete current & next message, delete current & previous message, delete all messages after & include current message, and delete all messages before & include current message.

COMMAND 21H

FUNCTION: REC/PLAY MISC FUNCTION

RETURN:

Table with 8 columns (DB7-DB0) and 3 rows showing bit patterns and mask values for the REC/PLAY command.

* THIS COMMAND ONLY VALID WHEN IN RECORD/PLAY MODE

Table with 4 columns: M, Function, Acknowledge, and Mode. Rows list various functions like Stop Recording, Stop Playing, REC/PLAY PAUSE ON/OFF, Turn on counter display on LCD, Delete playing message, Set REPEAT start/end point, Disable REPEAT mode, and Set Mark.

If HOST send command 21H/04H after REC or PLAY start, MX93521 will automatically display a 5-digit REC or PLAY counter MM:SS at current LCD cursor. MM is minute. SS is second.



COMMAND 28H
COMMAND 29H
COMMAND 2AH
COMMAND 2BH
COMMAND 2CH

FUNCTION : RECORD MSG

BBB = 000, 001, 010, 011, 100

RETURN : ACK2, MSGNUM_H, MSGNUM_L

RETURN : ACK1, FORMAT (VOCODER mode, FORMAT=81H when recording with new format)
(VOCODER mode, FORMAT=80H when recording with old format)

RETURN: ERR1, WHEN OUT OF FLASH MEMORY, CANNOT PERFORM RECORD

DB7	DB6	DB5	DB4	DB3	DB2	DB1	DB0	
0	0	1	0	1	B	B	B	
								USER DATA #1
								USER DATA #2
								USER DATA #3
								USER DATA #4

* USER DATA will be stored in the flash memory

* When RECORD, MX93521 will not switch MIC on automatically, HOST must turn on MIC before RECORD and turn off MIC after RECORD STOP

SAMPLES:

RECORD MESSAGE WITHOUT USER DATA	28H				
RECORD MESSAGE WITH 1 USER DATA 12H	29H	12H			
RECORD MESSAGE WITH 2 USER DATA 12H, 34H	2AH	12H	34H		
RECORD MESSAGE WITH 3 USER DATA 12H, 34H, 56H	2BH	12H	34H	56H	
RECORD MESSAGE WITH 4 USER DATA 12H, 34H, 56H, 78H	2CH	12H	34H	56H	78H

COMMAND 30H
COMMAND 31H

FUNCTION: PLAY MESSAGE

RETURN: ACK2, MSGNUM_H, MSGNUM_L, ACK0(Vocoder mode)

RETURN: ERR2, No Message to play

DB7	DB6	DB5	DB4	DB3	DB2	DB1	DB0	
0	0	1	1	0	0	0	1	
M	M	M	M	M	M	M	M	LENGTH (sec / unit)

M=000H, PLAY TILL THE END OF MESSAGE

M=001H, PLAY CURRENT MESSAGE FOR 1 SEC

M=080H, PLAY CURRENT MESSAGE FOR 128 SEC OR REACH THE END OF MESSAGE

M=0FFH, PLAY CURRENT MESSAGE FOR 255 SEC OR REACH THE END OF MESSAGE

* When PLAY, MX93521 will not switch SPKR on automatically, HOST must turn on SPKR before PLAY and turn off SPKR after PLAY STOP

SAMPLES:

PLAY MESSAGE TILL THE END OF MESSAGE	30H	
PLAY MESSAGE TILL THE END OF MESSAGE	31H	00H
PLAY FIRST 3 SEC OF CURRENT MESSAGE	31H	03H



COMMAND 32H

FUNCTION: Skip first M frames in the message with playback

RETURN: ACK2,MSGNUM_H,MSGNUM_L

DB7	DB6	DB5	DB4	DB3	DB2	DB1	DB0	
0	0	0	1	1	0	1	0	
H	H	H	H	H	H	H	H	Frame number (Hi-byte)
L	L	L	L	L	L	L	L	Frame number (Lo-byte) , 20ms/unit

SAMPLES:

PLAY THIS MESSAGE WITH SKIP FIRST 200 ms	32H	00H	0AH
--	-----	-----	-----

* This setting will be clear after play end of this message.

COMMAND 39H

FUNCTION: JUMP TO MARK

RETURN: ACK0

DB7	DB6	DB5	DB4	DB3	DB2	DB1	DB0
0	0	1	1	1	0	0	1
D	M	M	M	M	M	M	M

D=0, FORWARD

D=1, BACKWARD

M=00H, Normal Playing

M=01H, Forward/Rewind to the 1st found mark from current position

M=02H, Forward/Rewind to the 2nd found mark from current position

..

M=7FH, Forward/Backward to the 127th found mark from current position

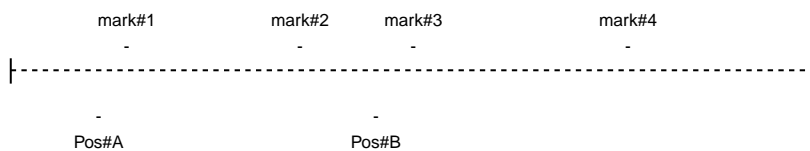

If current playing position is at Pos#A,

- command 39H/01H will forward to mark#1
- command 39H/02H will forward to mark#2
- command 39H/03H will forward to mark#3
- command 39H/04H will forward to mark#4
- command 39H/05H will forward to the end of message
- command 39H/81H will rewind to the head of message

If current playing position is at Pos#B,

- command 39H/01H will forward to mark#3
- command 39H/02H will forward to mark#4
- command 39H/03H will forward to the end of message
- command 39H/81H will rewind to mark#2
- command 39H/82H will rewind to mark#1
- command 39H/83H will rewind to the head of message

* If two marks are set too close to each other(<2 second), the second mark will be ignored.



COMMAND 3AH

FUNCTION: FAST FORWARD/BACKWARD PLAYING
RETURN: ACK0

Table with 8 columns (DB7-DB0) and 4 rows of bit data. Includes a note 'Unit Length (20ms/unit)'.

D=0, FORWARD

- M=00H, PLAY 1 UNIT, SKIP 0 UNIT (NORMAL PLAY SPEED)
M=01H, PLAY 1 UNIT, SKIP 1 UNIT (2x SPEED)
M=02H, PLAY 1 UNIT, SKIP 2 UNIT (3x SPEED)
M=03H, PLAY 1 UNIT, SKIP 3 UNIT (4x SPEED)
M=07H, PLAY 1 UNIT, SKIP 7 UNIT (8x SPEED)
..
M=7FH, PLAY 1 UNIT, SKIP 127 UNIT (128x SPEED)

D=1, BACKWARD

- M=01H, PLAY 1 UNIT, REWIND 1 UNIT (REPEAT SAME UNIT)
M=02H, PLAY 1 UNIT, REWIND 2 UNIT (1x SPEED REWIND)
M=03H, PLAY 1 UNIT, REWIND 3 UNIT (2x SPEED REWIND)
M=05H, PLAY 1 UNIT, REWIND 5 UNIT (4x SPEED REWIND)
..
M=7FH, PLAY 1 UNIT, REWIND 127 UNIT (126x SPEED)

SAMPLES:

Table with 4 columns: Description, 3AH, 00H, 01H. Lists various playback scenarios like 'NORMAL PLAYING', 'FORWARD TO THE 1ST FOUND MARK', etc.

COMMAND 41H

FUNCTION: MISC FUNCTION

RETURN:

DB7	DB6	DB5	DB4	DB3	DB2	DB1	DB0
0	1	0	0	0	0	0	1
M	M	M	M	M	M	M	M

M	Function	ACKNOWLEDGE	REMARK
01H	Toggle VOCODER mode	ACK0	
02H	Append Recording	ACK0	
03H	Overwrite Recording	ACK0	
04H	Toggle SPKR on/off	ACK0	valid only when using TP3054
05H	Voice Activated Recording ^{DR-V4}	ACK0	
06H	Linear mode codec interface ^{DR-V4}	ACK0	
07H	u-law mode codec interface ^{DR-V4}	ACK0	
08H	Toggle MIC on/off	ACK0	valid only when using TP3054
09H	Play accross message boundary ^{DR-V4}	ACK0	
0AH	Play within message boundary ^{DR-V4}	ACK0	
0BH ⁴	Direct CODEC Access ^{DR-V5}	ACK0	
0CH ⁵	Old data format ^{DR-V5}	ACK0	
0DH ⁵	New data format ^{DR-V5}	ACK0	
10H ¹	Erase all message	ACK0	ack after erase complete
11H ²	Hard erase flash memory ^{DR-V4}	ACK0	ack after erase complete
12H	Reinitial flash memory	ACK0	ack after erase complete
20H	Check busy/Idle status	ACK0 / ERR4	
40H	Check available block	ACK2,BLKCNT_H, BLKCNT_L	
41H	Check total block ^{DR-V4}	ACK2,BLKCNT_H, BLKCNT_L	
42H	Check available time ^{DR-V4}	ACK2,MIN,SEC	
43H	Check total time ^{DR-V4}	ACK2,MIN,SEC	
44H	Check message length ^{DR-V4}	ACK2,MIN,SEC	
80H ³	Overrun counter	ACK2,CNT_H,CNT_L	VOCODER mode
81H ³	Get Message Checksum ^{DR-V4}	ACK2,CS_H,CS_L	VOCODER mode

¹ The command 41H/10H erase all data in good blocks. After block erase, the flash management data will be written back to the flash memory. If HOST use flash memory as speech data memory and data bank memory. The command 41H/10H will erase both of the memory. To erase only speech memory, use command 19H. To erase data bank memory, use command 0CAH. The commands to control data bank memory are described from command 0B0H to command 0D6H

² Prior Samsung ship their flash memory to customer, they will test the parts and randomly write data 00H to those bad blocks. During the first power on, MX93521 will scan flash memory and create a good/bad table accordingly. After that, MX93521 will search the good/bad table during power on initialization. Unless good/bad table is missing, MX93521 will not do flash memory initialization again.



We call command 41H/11H is hard erase flash memory. Because this command will erase all data in both good and bad blocks. It is possible to erase the data in those bad blocks and turn the bad blocks into good block. In this case, the original bad blocks could be unstable during normal operation. So, we are not recommend to use this command unless it is necessary.

After send command 41H/11H, HOST should issue a hardware reset by toggling RST\.

³ Command 41H/80H & 41H/81H are only valid after recording in VOCODER mode.

⁴ HOST could send PCM or u-law format data to CODEC directly. In this mode, MX93521 send PCM/u-Law data received from HOST to CODEC (MX93000 or TP3054). MX93521 could store up to 512 samples data internally. If inetrnal buffer is empty, MX93521 will disable this mode automatically and send CMD 10H to HOST. At the beginning of Direct CODEC Access mode, MX93512 will not send data to CODEC until MX93521 received 384 samples from HOST.

⁵ Old data format is the data format used in MX93510 and MX93521 V3. New data format is used in MX93521 V4 and V5. New format supports silence compression. It is always set to use new data format in MX93521 V4. MX93521 V5 will reset to use new data format after power on, RECORD or PLAY. So, if HOST want to RECORD or PLAY message using old data format, HOST needs to send command 41H/0CH every time before sending RECORD or PLAY command to MX93521.

COMMAND 42H

FUNCTION: DETECT M FRAMES SILENCE ON THE PLAY/RECORD MODE

RETURN: ACK0

DB7	DB6	DB5	DB4	DB3	DB2	DB1	DB0	
0	0	1	0	0	0	1	0	
H	H	H	H	H	H	H	H	Silence Frame number (Hi-byte)
L	L	L	L	L	L	L	L	Frame number (Lo-byte) , 20ms/unit

SAMPLES:

DETECT 500 ms SILENCE ON THE PLAY/RECORD MODE	42H	00H	19H
---	-----	-----	-----

* This setting will be clear after play end of this message.

* When detect the silence condition , mx93521 will response the data of 28H

COMMAND 48H^{DR-V5}

FUNCTION: Tone Off

RETURN: ACK0

DB7	DB6	DB5	DB4	DB3	DB2	DB1	DB0	
0	1	0	0	1	0	0	0	Tone Off

COMMAND 49H

FUNCTION: BEEP GENERATOR

RETURN: ACK0

DB7	DB6	DB5	DB4	DB3	DB2	DB1	DB0	
0	1	0	0	1	0	0	1	1000Hz TONE (100ms on / 100ms off)
C	C	C	C	C	G	G	G	GAIN

CCCCC: BEEP COUNT, MAXIMUM 31 BEEPS



COMMAND 4BH

FUNCTION: TONE GENERATOR

RETURN: ACK0

DB7	DB6	DB5	DB4	DB3	DB2	DB1	DB0	
0	1	0	0	1	0	1	1	TONE
L	L	L	L	L	G	G	G	LENGTH (100ms/unit) & GAIN
F15	F14	F13	F12	F11	F10	F9	F8	TONE FREQ (HIGH BYTE)
F7	F6	F5	F4	F3	F2	F1	F0	TONE FREQ (LOW BYTE)
GGG: 000	GAIN= -18		dB,		100	GAIN= -42		dB
001	GAIN= -24		dB,		101	GAIN= -48		dB
010	GAIN= -30		dB,		110	GAIN= -56		dB
011	GAIN= -36		dB,		111	GAIN= -62		dB

COMMAND 4EH^{DR-V5}

COMMAND 4FH^{DR-V5}

FUNCTION: DUAL TONE GENERATOR

RETURN: ACK0

DB7	DB6	DB5	DB4	DB3	DB2	DB1	DB0	
0	1	0	0	1	1	1	0	
F15	F14	F13	F12	F11	F10	F9	F8	TONE#1 FREQ (HIGH BYTE)
F7	F6	F5	F4	F3	F2	F1	F0	TONE#1 FREQ (LOW BYTE)
F15	F14	F13	F12	F11	F10	F9	F8	TONE#2 FREQ (HIGH BYTE)
F7	F6	F5	F4	F3	F2	F1	F0	TONE#2 FREQ (LOW BYTE)
G1	G1	G1	G1	G1	G1	G1	G1	Scale for TONE#1
G2	G2	G2	G2	G2	G2	G2	G2	Scale for TONE#2

DB7	DB6	DB5	DB4	DB3	DB2	DB1	DB0	
0	1	0	0	1	1	1	1	
F15	F14	F13	F12	F11	F10	F9	F8	TONE#1 FREQ (HIGH BYTE)
F7	F6	F5	F4	F3	F2	F1	F0	TONE#1 FREQ (LOW BYTE)
F15	F14	F13	F12	F11	F10	F9	F8	TONE#2 FREQ (HIGH BYTE)
F7	F6	F5	F4	F3	F2	F1	F0	TONE#2 FREQ (LOW BYTE)
G1	G1	G1	G1	G1	G1	G1	G1	Scale for TONE#1
G2	G2	G2	G2	G2	G2	G2	G2	Scale for TONE#2
L	L	L	L	L	L	L	L	Length (10ms/unit)



$$F = (\text{FREQ}/8000) * 65536$$

TONE (#)	FREQ (HZ)	F (DECIMAL)	F (HEX)	F (HIGH)	F (LOW)
C5	523.25	4286.464	10BEH	10H	BEH
D5	587.33	4811.407	12CBH	12H	CBH
E5	659.26	5400.658	1519H	15H	19H
F5	698.46	5721.784	165AH	16H	5AH
G5	783.99	6422.446	1916H	19H	16H
A5	880.00	7208.960	1C29H	1CH	29H
B5	987.77	8091.812	1F9CH	1FH	9CH
C6	1046.50	8572.928	217DH	21H	7DH
D6	1174.66	9622.815	2597H	25H	97H
E6	1328.51	10883.154	2A83H	2AH	83H
F6	1396.91	11443.487	2CB3H	2CH	B3H
G6	1567.98	12844.892	322DH	32H	2DH
A6	1760.00	14417.920	3852H	38H	52H
B6	1975.53	16183.542	3F38H	3FH	38H
C7	2093.00	17145.856	42FAH	42H	FAH

DTMF	F1 (Hz)	F1 (Dec)	F1 (Hex)	F2 (Hz)	F2 (Dec)	F2 (Hex)
1	1209	9904.1	26B0H	697	5709.8	164EH
2	1336	10944.5	2AC1H	697	5709.8	164EH
3	1477	12099.6	2F44H	697	5709.8	164EH
A	1633	13377.5	3442H	697	5709.8	164EH
4	1209	9904.1	26B0H	770	6307.8	18A4H
5	1336	10944.5	2AC1H	770	6307.8	18A4H
6	1477	12099.6	2F44H	770	6307.8	18A4H
B	1633	13377.5	3442H	770	6307.8	18A4H
7	1209	9904.1	26B0H	852	6979.6	1B44H
8	1336	10944.5	2AC1H	852	6979.6	1B44H
9	1477	12099.6	2F44H	852	6979.6	1B44H
C	1633	13377.5	3442H	852	6979.6	1B44H
*	1209	9904.1	26B0H	941	7708.7	1E1DH
0	1336	10944.5	2AC1H	941	7708.7	1E1DH
#	1477	12099.6	2F44H	941	7708.7	1E1DH
D	1633	13377.5	3442H	941	7708.7	1E1DH

*For command 49H, 4BH, 4EH and 4FH. HOST have to make sure SPKR is on when using this commands.

*User could use scale factor in command 4EH&4FH combined with CODEC gain setting to set the desirable DTMF tone level



SAMPLES:

PLAY 2 BEEPS W/ -42DB GAIN	49H	14H		
PLAY TONE #C5 (523HZ) W/ -36DB GAIN FOR 2 SECOND	4BH	A3H	10H	BEH
PLAY TONE #E5 (659HZ) W/ -48DB GAIN FOR 1 SECOND	4BH	55H	15H	19H
Play DTMF-1 (High tone is 6 dB higher than low tone)	4EH	26H	B0H	16H 4EH FFH 7FH
Play DTMF-0 (High tone is 6 dB lower than low tone) 100ms	4FH	2AH	C1H	1EH 1DH 3FH 7FH 0AH
STOP PLAYING DTMF TONE	48H			

COMMAND 51H

FUNCTION: WRITE OUTPUT PORT UO0-2

RETURN: ACK0

DB7	DB6	DB5	DB4	DB3	DB2	DB1	DB0
0	1	0	1	0	0	0	1
X	X	X	X	X	UO2	UO1	UO0

*CMD 51H is only available in version DR-V3 and DR-V4

COMMAND 5AH

FUNCTION: MX93000 CODEC MISC. FUNCTION

RETURN: ACK0 or ERR7

DB7	DB6	DB5	DB4	DB3	DB2	DB1	DB0
0	1	0	1	1	0	1	0
X	X	X	X	X	A2	A1	A0
D7	D6	D5	D4	D3	D2	D1	D0

*Please reference to MX93000 data sheet for the definition of the MX93000 registers

SAMPLES:

Turn on MX93000 MIC path	5AH	00H	48H
Turn off MX93000 MIC path	5AH	00H	01H
Set MIC to maxima gain	5AH	02H	0FH
Set MIC to minima gain	5AH	02H	00H
Turn on MX93000 SPKR path	5AH	00H	03H
Turn off MX93000 SPKR path	5AH	00H	01H
Set SPKR to maxima gain	5AH	03H	00H
Set SPKR to minima gain	5AH	03H	0FH



COMMAND 61H

FUNCTION: LED DISPLAY FUNCTION

RETURN: ACK0

DB7	DB6	DB5	DB4	DB3	DB2	DB1	DB0
0	1	1	0	0	0	0	1
LED2	LED1	T	T	T	T	T	T

LED1=1, LED1 ON (MX93521 PIN5 LOW)

LED2=1, LED2 ON (MX93521 PIN4 LOW)

TTTTTT=0, NO FLASH

TTTTTT¹0, FLASH TIMER (64ms/unit)

SAMPLES:

LED1 STAY ON	61H	40H
LED2 STAY ON	61H	80H
LED1 FLASH (512ms ON / 512ms OFF)	61H	48H
LED2 FLASH (1024ms ON / 1024ms OFF)	61H	90H
LED1 & LED2 FLASH (128ms ON / 128ms OFF)	61H	C2H
LED1 & LED2 OFF	61H	00H



COMMAND 6AH

COMMAND 6CH

COMMAND 6EH

FUNCTION: WRITE COMPRESSED VOICE DATA TO MX93521 FOR PLAYING (VOCODER mode)

RETURN: ACK0 / ERR5

BBB = 010, 100, 110

DB7	DB6	DB5	DB4	DB3	DB2	DB1	DB0	
0	1	1	0	1	B	B	B	WRITE DATA TO MX93521
								BYTE#1
								BYTE#2
								BYTE#3
								BYTE#4
								BYTE#5
								BYTE#6

MX93521 equipped a 64 words PLAY BUFFER, HOST should keep feeding compressed voice data to MX93521 when doing PLAY function. Once PLAY BUFFER have no enough data to play, MX93521 will stop playing and send command 10H to HOST. When the PLAY BUFFER is full, MX93521 will response ERR5. If this is the case, HOST should re-send this command later. HOST must feed MX93521 at least 12 bytes data per 20 mini-second. When HOST send command 30H, MX93521 will not start to play until received first 60 bytes data.

The procedure to do PLAY function in VOCODER mode:

STEP1: Turn on VOCODER mode (send command 41H/01H)

STEP2: Turn on SPKR

STEP3: Set PLAY mode (Send command 30H)

STEP4: Send Compressed Voice data to MX93521 (Send command 6?H+BYTE+BYTE+..)

STEP5: If received ACK0, goto STEP4 to send next 6AH/6CH/6EH command

 If received ERR5, wait 20-180 ms, then go back to STEP4 to re-send previous command

 If HOST want to stop PLAY function or HOST reach the end of message, then goto STEP6

 If received 10H, goto STEP7 (HOST did not send data to MX93521 fast enough)

STEP6: Wait until MX93521 play out data in PLAY BUFFER (receiveing command 10H from MX93521)

STEP7: Turn off SPKR

STEP8: Turn off VOCODER mode (send command 41H/01H).



- COMMAND 70H**
- COMMAND 71H**
- COMMAND 72H**
- COMMAND 73H**
- COMMAND 74H**
- COMMAND 75H**
- COMMAND 76H**
- COMMAND 77H**

FUNCTION: WRITE LCD DATA
BBB = 000, 001, 010, 011, 100, 101, 110, 111
RETURN: ACK0

DB7	DB6	DB5	DB4	DB3	DB2	DB1	DB0	
0	1	1	1	0	B	B	B	LCD DATA
								BYTE#1
								BYTE#2
								BYTE#3
								BYTE#4
								BYTE#5
								BYTE#6
								BYTE#7

* THIS COMMAND ONLY VALID WHEN MX93521 SET TO SERIAL INTERFACE MODE

SAMPLES:

DISPLAY [ABCD] ON LCD LINE 1	74H	41H	42H	43H	44H
------------------------------	-----	-----	-----	-----	-----

COMMAND 79H

FUNCTION: WRITE LCD COMMAND
RETURN: ACK0

DB7	DB6	DB5	DB4	DB3	DB2	DB1	DB0	
0	1	1	1	1	0	0	1	
C7	C6	C5	C4	C3	C2	C1	C0	

* THIS COMMAND ONLY VALID WHEN MX93521 SET TO SERIAL INTERFACE MODE



LCD COMMAND SET:

C7	C6	C5	C4	C3	C2	C1	C0		
0	0	0	0	0	0	0	1	01H	Clear Display
0	0	0	0	0	0	1	X	02H	Cursor return Home
0	0	0	0	0	1	0	0	04H	Cursor-1, no shift
0	0	0	0	0	1	0	1	05H	Cursor-1, shift
0	0	0	0	0	1	1	0	06H	Cursor+1, no shift
0	0	0	0	0	1	1	1	07H	Cursor+1, shift
0	0	0	0	1	0	0	0	08H	Display off
0	0	0	0	1	1	0	0	0CH	Display on, Cursor off, Blink off
0	0	0	0	1	1	0	1	0DH	Display on, Cursor off, Blink on
0	0	0	0	1	1	1	0	0EH	Display on, Cursor on, Blink off
0	0	0	0	1	1	1	1	0FH	Display on, Cursor on, Blink on
0	0	0	1	0	0	X	X	10H	Move Cursor left
0	0	0	1	0	1	X	X	14H	Move Cursor right
0	0	0	1	1	0	X	X	18H	Display shift left
0	0	0	1	1	1	X	X	1CH	Display shift right
1	X	X	X	X	X	X	X	80H-FFH	Set DD RAM address
1	0	0	0	0	0	0	0	80H	Set cursor to the start of 1st line
1	1	0	0	0	0	0	0	C0H	Set cursor to the start of 2nd line

SAMPLES:

CLEAR LCD DISPLAY	79H	01H
SET CURSOR TO THE START OF LINE 1	79H	80H
SET CURSOR TO THE START OF LINE 2	79H	C0H
SET CURSOR TO THE LINE 2, 3RD COLUMN	79H	C2H
MOVE CURSOR LEFT	79H	10H
MOVE CURSOR RIGHT	79H	14H

EXAMPLE:

To Display [RECORD] at line #1 & [MM:SS] at line #2

CLEAR LCD DISPLAY & RETURN CURSOR TO HOME	79H	01H					
DISPLAY [RECORD] AT LCD LINE 1	76H	52H	45H	43H	4FH	52H	44H
SET CURSOR TO THE LINE 2, 4TH COLUMN	79H	C3H					
TURN ON COUNTER DISPLAY ON LCD	21H	04H					



COMMAND 8CH DR-V5

FUNCTION: Upload Data
RETURN: ACK0

DB7	DB6	DB5	DB4	DB3	DB2	DB1	DB0	
1	0	0	0	1	1	0	0	
D	D	D	D	D	D	D	D	High Byte
D	D	D	D	D	D	D	D	Low Byte
D	D	D	D	D	D	D	D	High Byte
D	D	D	D	D	D	D	D	Low Byte

COMMAND 8EH DR-V5

FUNCTION: Upload Data
RETURN: ACK0

DB7	DB6	DB5	DB4	DB3	DB2	DB1	DB0	
1	0	0	0	1	1	1	0	
D	D	D	D	D	D	D	D	High Byte
D	D	D	D	D	D	D	D	Low Byte
D	D	D	D	D	D	D	D	High Byte
D	D	D	D	D	D	D	D	Low Byte
D	D	D	D	D	D	D	D	High Byte
D	D	D	D	D	D	D	D	Low Byte

COMMAND 91H DR-V4

FUNCTION: Set Silence Level
RETURN: ACK0

DB7	DB6	DB5	DB4	DB3	DB2	DB1	DB0	
1	0	0	1	0	0	0	1	
x	x	x	x	L	L	L	L	Level

LLLL=0000 (Level 0) Set Highest silence threshold (Some of the speech will be treated as silence)
LLLL=0011 (Level 3) Default value
LLLL=1111 (Level 15) Set Lowest silence threshold (All signal are treated as speech, No silence compression at all)

COMMAND 98H DR-V5

FUNCTION: Read ROM/RAM wait state setting
RETURN: ACK2, WSTH,WSTL

DB7	DB6	DB5	DB4	DB3	DB2	DB1	DB0	
1	0	0	1	0	0	0	0	



COMMAND 99H^{DR-V5}

FUNCTION: Set ROM/RAM wait state

RETURN: ACK0

DB7	DB6	DB5	DB4	DB3	DB2	DB1	DB0	
1	0	0	1	0	0	0	1	
0	0	0	0	A	A	A	A	Wait State
0000: RAM Wait State			AAAA: ROM Wait State					

COMMAND A2H^{DR-V4}

FUNCTION: Read MX93521 RAM

RETURN: ACK2, DATA_H, DATA_L

DB7	DB6	DB5	DB4	DB3	DB2	DB1	DB0	
1	1	0	1	0	0	1	0	
								Address (High)
								Address (Low)

COMMAND A4H^{DR-V4}

FUNCTION: Write MX93521 RAM

RETURN: ACK0

DB7	DB6	DB5	DB4	DB3	DB2	DB1	DB0	
1	1	0	1	0	1	0	0	
								Address (High)
								Address (Low)
								Data (High)
								Data (Low)

* Only for testing purpose, user should not change any data in the RAM area

COMMAND AAH^{DR-V5}

FUNCTION: Read MX93521 internal ROM

RETURN: ACK2, DATA_H, DATA_L

DB7	DB6	DB5	DB4	DB3	DB2	DB1	DB0	
1	1	0	1	0	0	1	0	
								Address (High)
								Address (Low)



COMMAND B0H^{DR-V4}

FUNCTION: Output all blocks which are used as data bank block

RETURN: ACK0

DB7	DB6	DB5	DB4	DB3	DB2	DB1	DB0
1	0	1	1	0	0	0	0

MX93521 return block number by sending command 32H/34H/36H and ended with command 30H

32H, BLK_H, BLK_L

34H, BLK_H, BLK_L, BLK_H, BLK_L

36H, BLK_H, BLK_L, BLK_H, BLK_L, BLK_H, BLK_L

30H

COMMAND B1H^{DR-V4}

FUNCTION: Read Flash Memory

RETURN: ACK0

DB7	DB6	DB5	DB4	DB3	DB2	DB1	DB0
1	0	1	1	0	0	0	1

Counter (read 1-255 byte from flash memory)

COMMAND B2H^{DR-V4}

FUNCTION: Read Flash Memory

RETURN: ACK0

DB7	DB6	DB5	DB4	DB3	DB2	DB1	DB0
1	0	1	1	0	0	1	0

CNT_H

CNT_L (read 1-65535 bytes from flash memory)

When continuously read flash memory, MX93521 will send data with command 3XH to HOST & ended with command 30H. The address pointer will point to the next byte of the last byte read. HOST could send another continuous read command 0B1H or 0B2H to read out following data from flash memory.

COMMAND B8H^{DR-V4}

FUNCTION: Request for data bank block

RETURN: ACK2, BLK_H, BLK_L

DB7	DB6	DB5	DB4	DB3	DB2	DB1	DB0
1	0	1	1	1	0	0	0



COMMAND CAH^{DR-V4}

FUNCTION: Erase Block (Release data block)

RETURN: ACK0 or ERR0

DB7	DB6	DB5	DB4	DB3	DB2	DB1	DB0
1	1	0	0	1	0	1	0
							Block (High)
							Block (Low)

COMMAND D4H^{DR-V4}

FUNCTION: Read 1 word data from flash memory

RETURN: ACK2, DATA_H, DATA_L

DB7	DB6	DB5	DB4	DB3	DB2	DB1	DB0
1	1	0	1	0	1	0	0
							Block (High)
							Block (Low)
							Address (High)
							Address (Low)

COMMAND D5H^{DR-V4}

FUNCTION: Write 1 byte data to flash memory

RETURN: ACK0

DB7	DB6	DB5	DB4	DB3	DB2	DB1	DB0
1	1	0	1	0	1	0	1
							Block (High)
							Block (Low)
							Address (High)
							Address (Low)
							Data

COMMAND D6H^{DR-V4}

FUNCTION: Write 1 word (2 bytes) data to flash memory

RETURN: ACK0

DB7	DB6	DB5	DB4	DB3	DB2	DB1	DB0
1	1	0	1	0	1	0	1
							Block (High)
							Block (Low)
							Address (High)
							Address (Low)
							Data (High)
							Data (Low)



COMMAND FAH^{DR-V5}

FUNCTION: Play Voice Prompt From ROM
RETURN: ACK0

DB7	DB6	DB5	DB4	DB3	DB2	DB1	DB0	
1	1	1	1	1	0	0	1	
								Voice Prompt ROM Starting address High Byte
								Voice Prompt ROM Starting address Low Byte

COMMAND FCH^{DR-V5}

FUNCTION: Play Voice Prompt from FLASH memory
RETURN: ACK0

DB7	DB6	DB5	DB4	DB3	DB2	DB1	DB0	
1	1	1	1	1	0	0	1	
								Flash Memory Block # (High Byte)
								Flash Memory Block # (Low Byte)
								Flash Memory Pointer (High Byte)
								Flash Memory Pointer (Low Byte)

Flash Memory Pointer range from 10H to 0FFE H

* When MX93521 received command 0FAH or 0FCH from HOST, MX93521 start to play voice prompt from ROM/FLASH. After playing out all data, MX93521 will send command 10H to HOST. The voice prompt data are compressed speech data which is ended with one 0000H or six 0FFFFH in the data stream.



6.4 MX93521 TO HOST COMMANDS

MX93521 will always respond a ACK if received a command from HOST. Besides that, MX93521 will send command to notify HOST that a specific event has happened. HOST could do action according to the command received.

COMMAND 10H

FUNCTION: Play mode, Reach the end of the playing message

DB7	DB6	DB5	DB4	DB3	DB2	DB1	DB0
0	0	0	1	0	0	0	0

COMMAND 18H

FUNCTION: Play mode, Reach the start of the playing message

DB7	DB6	DB5	DB4	DB3	DB2	DB1	DB0
0	0	0	1	1	0	0	0

COMMAND 20H

FUNCTION: Record mode, out of flash memory

DB7	DB6	DB5	DB4	DB3	DB2	DB1	DB0
0	0	1	0	0	0	0	0

COMMAND 42H

FUNCTION: MX93521 outputs record / play counter

DB7	DB6	DB5	DB4	DB3	DB2	DB1	DB0	
0	1	0	0	0	0	1	0	
M	M	M	M	M	M	M	M	Minute
S	S	S	S	S	S	S	S	Second

COMMAND 52H^{DR-V4}

FUNCTION: MX93521 outputs Message Number

DB7	DB6	DB5	DB4	DB3	DB2	DB1	DB0
0	1	0	1	0	0	1	0

Message number (high byte)

Message number (low byte)



- COMMAND 30H**^{DR-V4}
- COMMAND 31H**^{DR-V4}
- COMMAND 32H**
- COMMAND 33H**^{DR-V4}
- COMMAND 34H**^{DR-V4}
- COMMAND 35H**^{DR-V4}
- COMMAND 36H**
- COMMAND 37H**^{DR-V4}

FUNCTION: MX93521 outputs data with command 3XH and ending the function with command 30H

COMMAND 32H

FUNCTION: Vocoder record mode, MX93521 outputs compressed voice data (silence frame)

DB7	DB6	DB5	DB4	DB3	DB2	DB1	DB0
0	0	1	1	0	0	1	0
							BYTE #1
							BYTE #2

COMMAND 36H

FUNCTION: Vocoder record mode, MX93521 outputs compressed voice data (speech frame)

DB7	DB6	DB5	DB4	DB3	DB2	DB1	DB0
0	0	1	1	0	1	1	0
							BYTE #1
							BYTE #2
							BYTE #3
							BYTE #4
							BYTE #5
							BYTE #6

When in VOCODER mode, MX93521 use this command to send compressed voice data to HOST.
MX93521 equipped with 64 byte buffer internally. If buffer is full, data will be discarded.

**7. DC Characteristics**; $T_A=0$ to 70°C , $V_{CC}=5\text{V}\pm 10\%$ Storage temperature range; $T_G=55^{\circ}\text{C} - 150^{\circ}\text{C}$

SYMBOL	PARAMETER	CONDITION	MIN	TYP	MAX	UNIT
VCC	supply voltage		4.5	5.0	5.5	Volt
GND	ground			0		Volt
TTL LEVEL INPUT (IT)						
VIH	Input high voltage		2.0			V
VIL	Input low voltage				0.8	V
SCHMITT TRIGGER INPUT (IS)						
VIH	Input high voltage		$0.7 \cdot V_{CC}$			V
VIL	Input low voltage				$0.3 \cdot V_{CC}$	V
8mA OUTPUT (OA)						
VOH	Onput high voltage	$I_{OH}=-8\text{mA}$	2.4			
VOL	Onput low voltage	$I_{OL}=8\text{mA}$			0.4	V
16mA OUTPUT (OB)						
VOH	Onput high voltage	$I_{OH}=-16\text{mA}$	2.4			V
VOL	Onput low voltage	$I_{OL}=16\text{mA}$			0.4	V
SUPPLY CERRENT						
ICC	NORMAL			45	70	mA
ICC	HOLD MODE			10		mA
ICC	POWER DOWN			3	6	mA

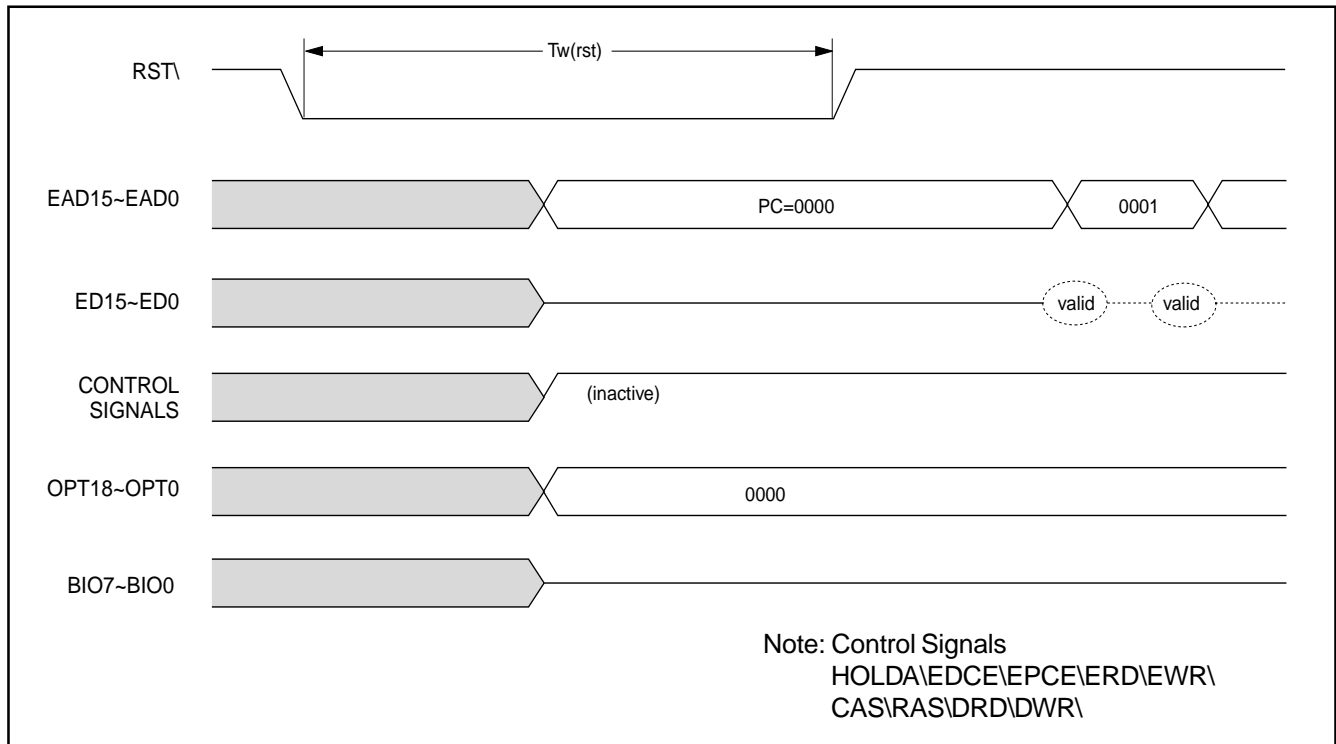
8.AC TIMING AND CHARACTERISTICS:
RESET TIMING

SYMBOL	PARAMETER	MIN	NOM	MAX	UNIT
Tw(rst)	Reset low pulse width	2*46.5ns			

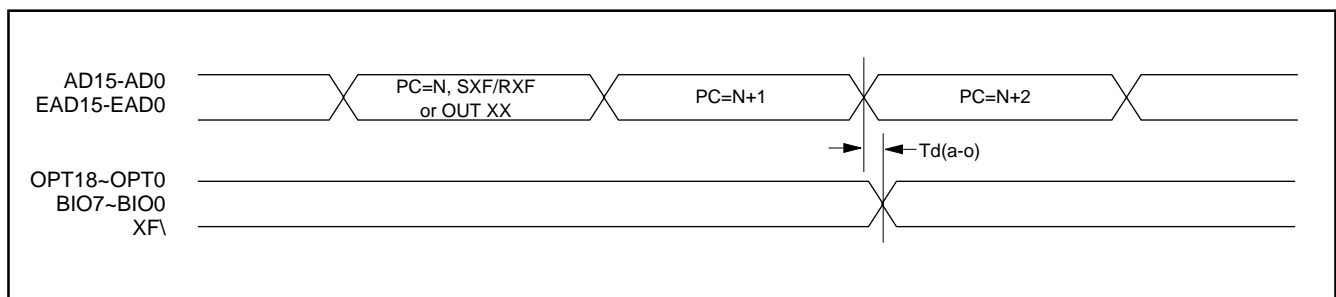
OUTPUT PORT TIMING

OUTPUT PORTS AND EXTERNAL FLAG(XF) TIMING

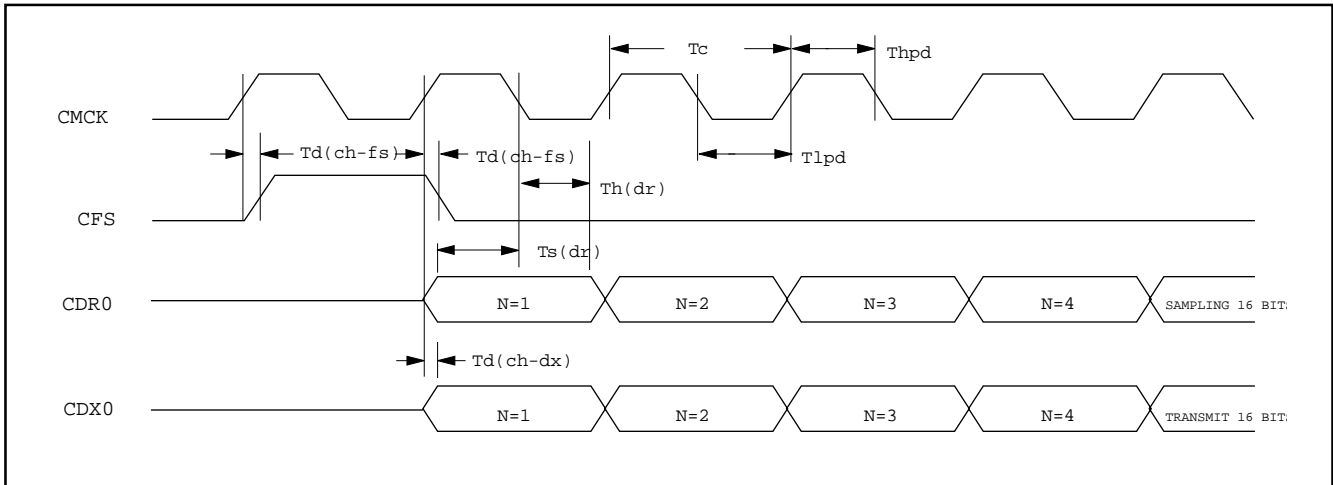
SYMBOL	PARAMETER	MIN	NOM	MAX	UNIT
Td(a-o)	Address to output ports delay time	0		10	ns

CODEC TRANSMIT AND RECEIVE TIMING

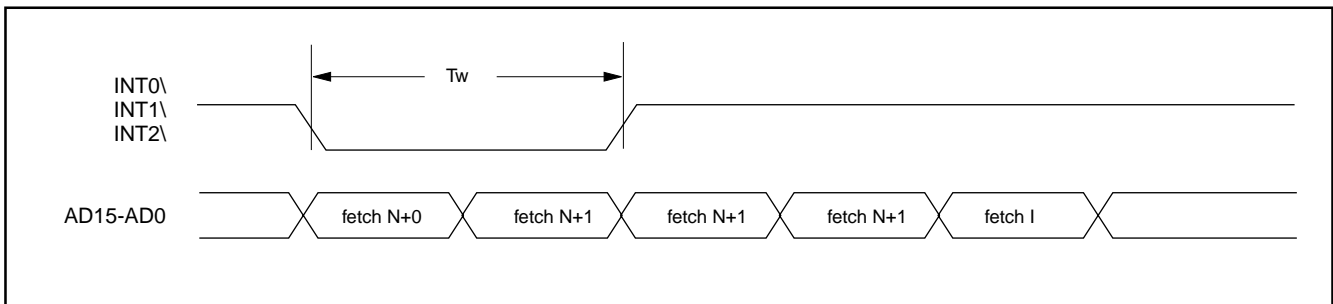
SYMBOL	PARAMETER	MIN	NOM	MAX	UNIT
Tc	CMCK cycle time		650		ns
Tlpd	CMCK low pulse duration	315		335	ns
Thpd	CMCK high pulse duration	315		335	ns
Td(ch-fs)	CMCK to CFS delay time			20	ns
Td(ch-dx)	CMCK rising edge to Dx valid			10	ns
Ts(dr)	DR set-up time before CMCK falling edge	10			ns
Th(dr)	DR hold time before CMCK falling edge	10			ns

INTERRUPT TIMING

SYMBOL	PARAMETER	MIN	NOM	MAX	UNIT
Tw	INT\ low pulse duration	3Q*			ns

NOTE: Q=15.5 ns

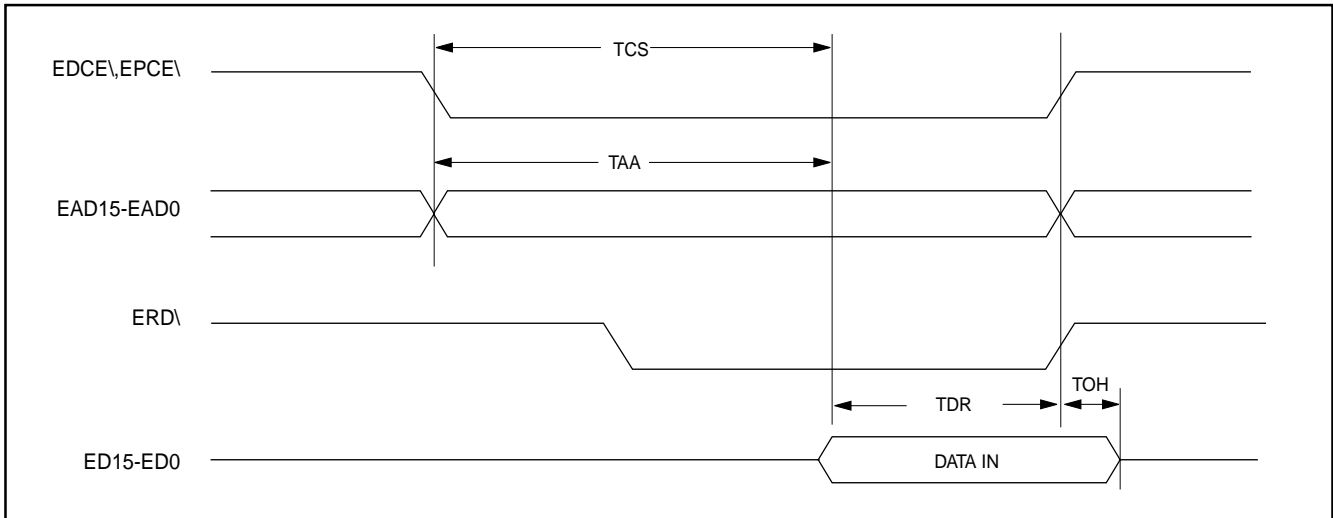
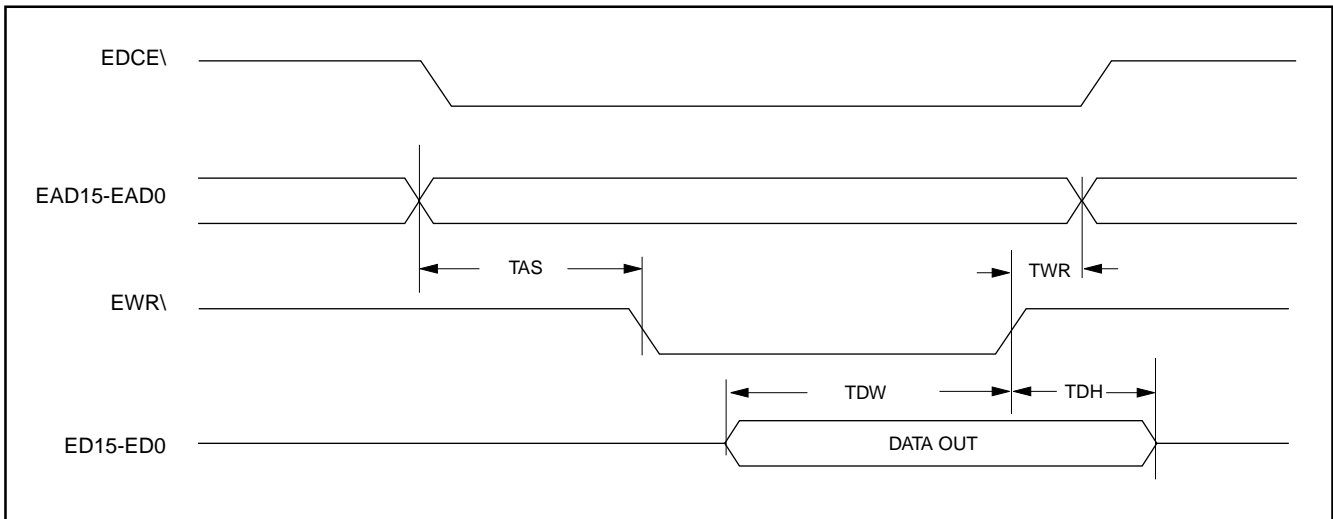
SRAM/ROM READTIMING

SRAM WRETTIMING

SYMBOL	PARAMETER	MIN	NOM	MAX	UNIT
TCS	Chip select access time			26.5+WxT	ns
TAA	Address access time			26.5+WxT	ns
TDR	Data read setup time	12			ns
TOH	Data hold from end of read	0			ns
TAS	Address setup time	0		5	ns
TDW	Data to EWR\ low overlap			12	ns
TDH	Data hold from end of write	0			ns
TWR	Write recovery time	0			ns

*NOTE: T=31ns

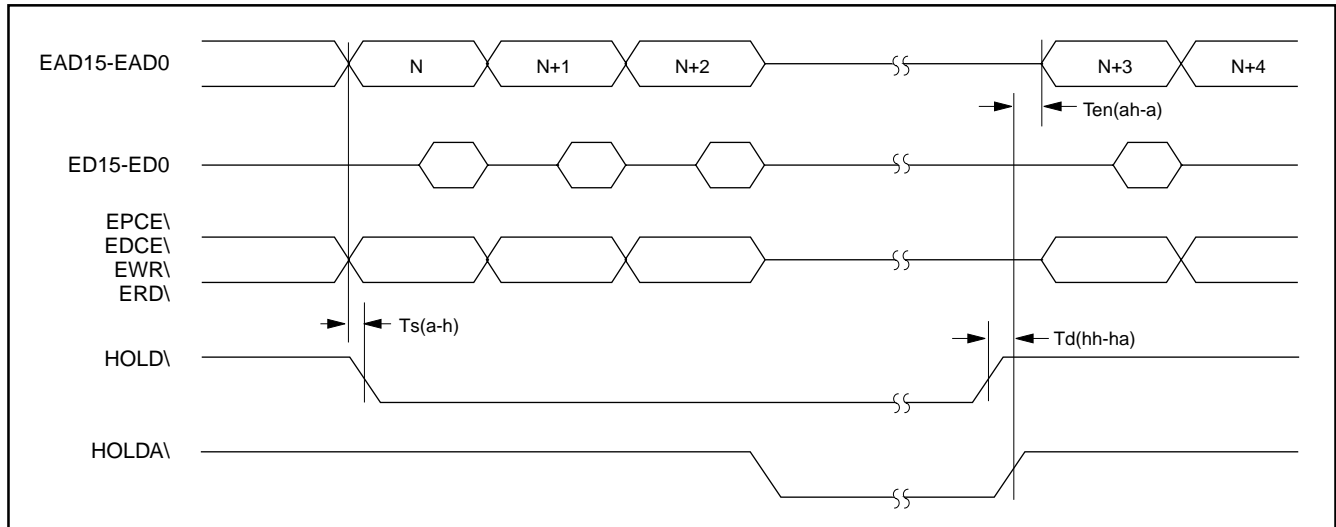
W:Wait state number

HOLD TIMING

SYMBOL	PARAMETER	MIN	NOM	MAX	UNIT
Ts(a-h)	Address set-up time before HOLD\ low	5		3Q-10	ns
Td(hh-ha)	HOLD\ high to HOLDA\ high	0	1Q	1Q+10	ns
Ten(ah-a)	Address driven after HOLDA\ high	1Q-10	1Q	2Q	ns

*NOTE: Q=15.5n

9.PACKAGE INFORMATION
100-PIN LQFP

ITEM	MILLIMETERS	INCHES
A	16.00 ± .05	.630 ± .002
B	14.00 ± .05	.551 ± .002
C	14.00 ± .05	.551 ± .002
D	16.00 ± .05	.630 ± .002
E	12.00 [REF]	.472 [REF]
F	.60 [REF]	.024 [REF]
G	.60 [REF]	.024 [REF]
H	.16 [Typ.]	.006 [Typ.]
I	.50 [Typ.]	.020 [Typ.]
J	1.00 [Typ.]	.039 [Typ.]
K	0.60 [Typ.]	.024 [Typ.]
L	.25 [Typ.]	.010 [Typ.]
M	.10 max.	.004 max.
N	1.4 ± .05	.055
O	.10 min.	.004 min.
P	1.50 max.	.059 max.

NOTE: Each lead centerline is located within .25mm [.01 inch] of its true position [TP] at a maximum material condition.

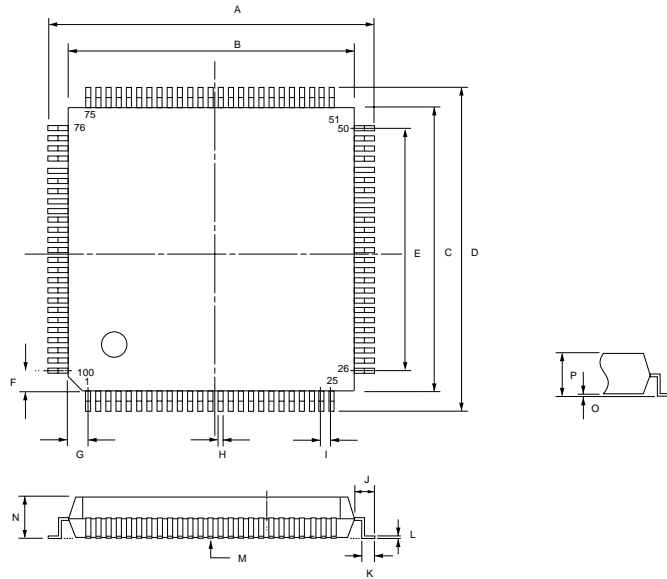
100-PIN PQFP

ITEM	MILLIMETERS	INCHES
A	24.80 ± .40	.976 ± .016
B	20.00 ± .13	.787 ± .005
C	14.00 ± .13	.551 ± .005
D	18.80 ± .40	.740 ± .016
E	12.35 [REF]	.486 [REF]
F	.83 [REF]	.033 [REF]
G	.58 [REF]	.023 [REF]
H	.30 [Typ.]	.012 [Typ.]
I	.65 [Typ.]	.026 [Typ.]
J	2.40 [Typ.]	.094 [Typ.]
K	1.20 [Typ.]	.047 [Typ.]
L	.15 [Typ.]	.006 [Typ.]
M	.10 max.	.004 max.
N	2.75 ± .15	.108 ± .006
O	.10 min.	.004 min.
P	3.30 max.	.103 max.

NOTE: Each lead centerline is located within .25mm [.01 inch] of its true position [TP] at a maximum material condition.

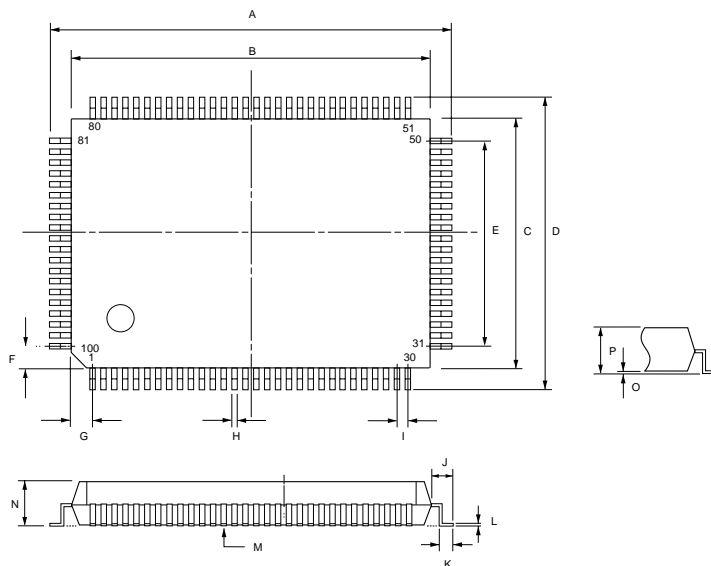



10. Ordering Information

PART NO.	PACKAGE
MX93521FC	PQFP
MX93521UC	LQFP

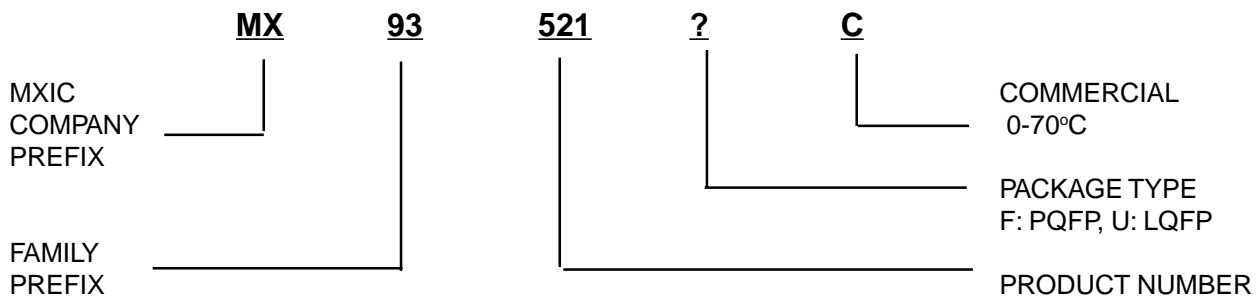

Appendix 1. New added Features Compared with DR-V4

New features in dr-v5

- 1.Support both format used in v3 (without silence compression) and v4 (with silence compression)
- 2.Add version number and date information at rom address 10h-13h
- 3.Add direct codec accessing function
- 4.Add command 0AH (point to specific message)
- 5.Add DTMF tone generator
- 6.Add upload message from host to mx93521 function
- 7.Add command 99H (change rom/ram wait state)
- 8.Add play voice prompt from flash memory function
- 9.Change silence threshold setting

New features in dr-v6

- 1.Add silence detection function
- 2.New codec.asm that improve tone response
- 3.Add safe_chip_erase function (erase only good blocks)
- 4.Improve find_empty_blk subroutine
- 5.Add skip frames function in play mode

Appendix 2. Sample Flow Chart for HOST to Implement uP Serial Interface

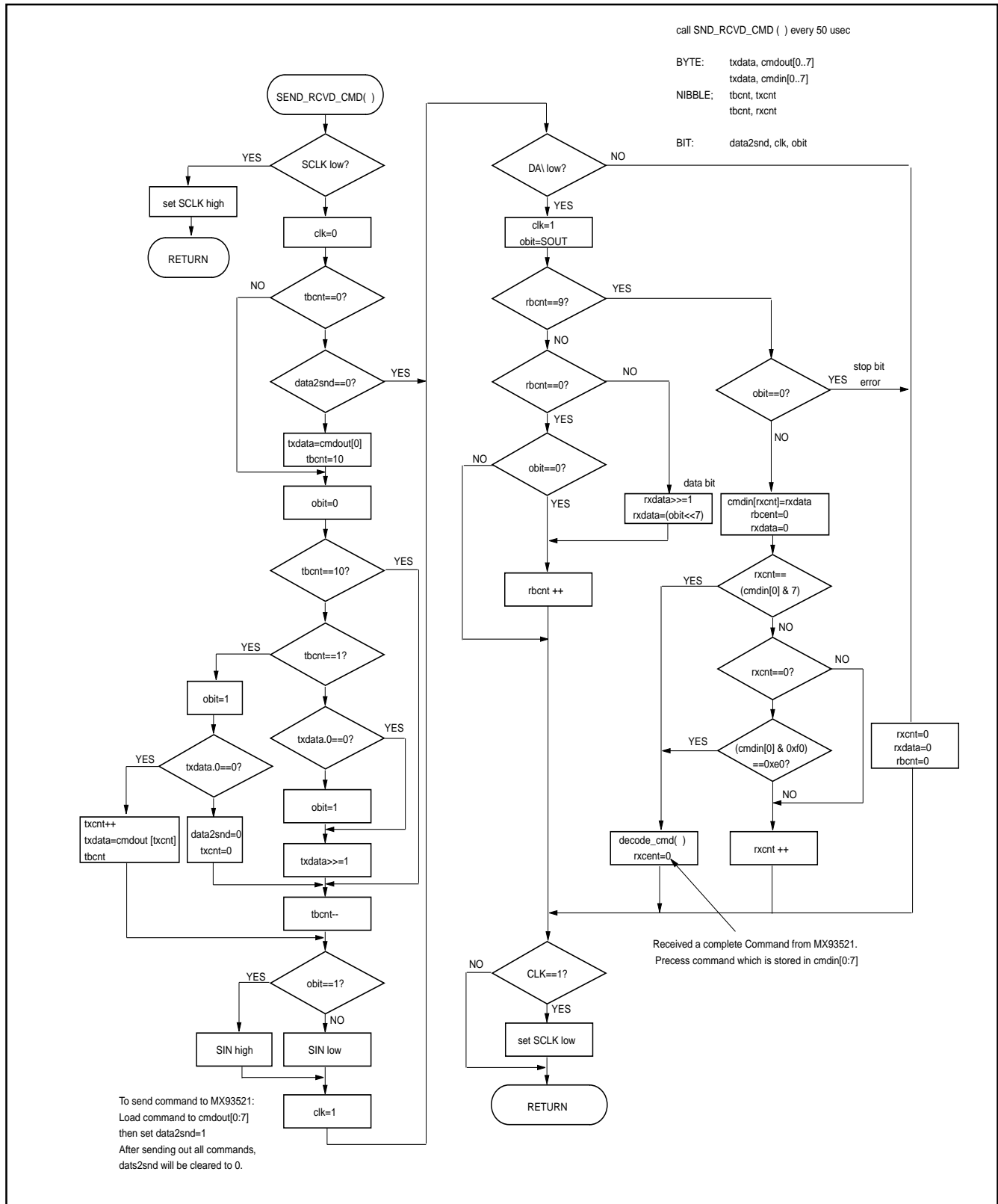

**Appendix 3. Recommend commands sequence to implement a digital recorder**

(star* means function is optional)

A3.1 Record Message (TP3054):

Functions	HOST send	MX93521 Acknowledge
* Turn on SPKR	41H/04H	ACK0
* Beep	49H/0AH	ACK0
* Turn off SPKR	41H/04H	ACK0
Turn on MIC	41H/08H	ACK0
* LED #1 flash	61H/48H	ACK0
* Append Recording	41H/02H	ACK0
* Overwrite Recording	41H/03H	ACK0
* Turn on Voice Activated Mode	41H/05H	ACK0
Start to Record	28H	ACK2,MSG#_H,MSG#_L
* Clear LCD	79H/01H	ACK0
* Display [RECORD] on LCD	76H/52H/45H/43H/4FH/52H/44H	ACK0
* Move cursor to line #2, col #3	79H/C3H	ACK0
* Turn on message counter display on LCD	21H/04H	ACK0

A3.2 Stop Recording (TP3054):

Functions	HOST send	MX93521 Acknowledge
Stop Recording	21H/01H	ACK2,CHKSUM_H, CHKSUM_L
Turn off MIC	41H/08H	ACK0
* LED #1 off	61H/00H	ACK0
* Turn on SPKR	41H/04H	ACK0
* Beep	49H/0AH	ACK0
* Turn off SPKR	41H/04H	ACK0

A3.3 Out of Memory, Received command 20H from MX93521 during Recording (TP3054):

Functions	HOST send	MX93521 Acknowledge
Turn off MIC	41H/08H	ACK0
* LED #1 off	61H/00H	ACK0
* Turn on SPKR	41H/04H	ACK0
* Beep	49H/0AH	ACK0
* Turn off SPKR	41H/04H	ACK0

**A3.4 Play Message (TP3054):**

Functions	HOST send	MX93521 Acknowledge
Move message pointer to specific message	09H/xxH	ACK0/ERR6
Turn on SPKR	41H/04H	ACK0
* Beep	49H/0AH	ACK0
* LED #2 flash	61H/88H	ACK0
Start to Play	30H	ACK2,MSG#_H,MSG#_L
* Send msg counter to HOST every 512 ms	81H/04H	ACK0
* Clear LCD	79H/01H	ACK0
* Display [PLAY] on LCD	74H/50H/4CH/41H/59H	ACK0
* Move cursor to line #2, col #3	79H/C3H	ACK0
* Turn on message counter display on LCD	21H/04H	ACK0

A3.5 Function During Playing Message

Functions	HOST send	MX93521 Acknowledge
* Fast Forward Playing (2x)	3AH/01H/01H	ACK0
* Rewind Playing (2x)	3AH/81H/01H	ACK0
* Set REPEAT start point	21H/10H	ACK0
* Set REPEAT end point	21H/20H	ACK0
* Disable REPEAT mode	21H/40H	ACK0

A3.6 Stop Playing Message (TP3054):

Functions	HOST send	MX93521 Acknowledge
Stop Playing	21H/01H	ACK0
* LED #2 off	61H/00H	ACK0
* Beep	49H/0AH	ACK0
Turn off SPKR	41H/04H	ACK0

A3.7 End of Message, Received command 10H from MX93521 during Playing (TP3054):

Functions	HOST send	MX93521 Acknowledge
* LED #2 off	61H/00H	ACK0
* Beep	49H/0AH	ACK0
Turn off SPKR	41H/04H	ACK0



A3.8 Message Search

	Functions	HOST send	MX93521 Acknowledge
1	Turn on SPKR	41H/04H	ACK0
2	Move message pointer to the 1st msg	09H/FFH	ACK0/ERR6
3	Play current message for 3 second	31H/03H	ACK0
4			10H
5	Move message pointer to the next message	09H/01H	ACK0/ERR6
6	if received ACK0, goto Step #3		
	if received ERR6, goto Step #7		
7	Turn off SPKR	41H/04H	ACK0

A3.9 Message Found

	Functions	HOST send	MX93521 Acknowledge
1	Stop playing	21H/01H	ACK0
2	Play current message	30H	ACK0
3	Turn off SPKR	41H/04H	ACK0

A3.10 The procedure for using flash memory as data bank memory

		HOST SEND	MX93521 RESPONSE
1	Request a empty block to be used as data block	0B8H	0A2H, BLK_H, BLK_L
2	Set continuous read start address	0BCH, BLK_H, BLK_L, ADR_H, ADR_L	0A0H
3	Continuous Read 20 bytes	0B1H, 14H	0A0H 037H,D1,D2,D3,D4,D5,D6,D7 037H,D1,D2,D3,D4,D5,D6,D7 036H,D1,D2,D3,D4,D5,D6 030H
	Continuous Read 298 bytes	0B2H, 01H,2AH	0A0H 037H,D1,D2,D3,D4,D5,D6,D7 037H,D1,D2,D3,D4,D5,D6,D7 034H,D1,D2,D3,D4 030H
4	Continuous Write 7 bytes	0C7H,D1,D2,D3,D4,D5,D6,D7	0A0H
	Continuous Write 6 bytes	0C6H,D1,D2,D3,D4,D5,D6	0A0H
	Continuous Write 5 bytes	0C5H,D1,D2,D3,D4,D5	0A0H
	Continuous Write 4 bytes	0C4H,D1,D2,D3,D4	0A0H
	Continuous Write 3 bytes	0C3H,D1,D2,D3	0A0H
	Continuous Write 2 bytes	0C2H,D1,D2	0A0H
	Continuous Write 1 bytes	0C1H,D1	0A0H
5	Erase Block	CAH, BLK_H, BLK_L	0A0H
6	Read 1 word from flash memory	0D4H, BLK_H, BLK_L, ADR_H, ADR_L	0A2H, DATA1, DATA2
7	Write 1 byte to flash memory	0D5H, BLK_H, BLK_L, ADR_H, ADR_L, D1	0A0H
8	Write 2 bytes to flash memory	0D6H, BLK_H, BLK_L, ADR_H, ADR_L, D1, D2	0A0H

Each block in flash memory is 4K byte. The first 16 bytes are reserved for MX93521 as data link data, HOST could read but could not write data to it. So, the host usable data are from address 10H-0FFFFH.

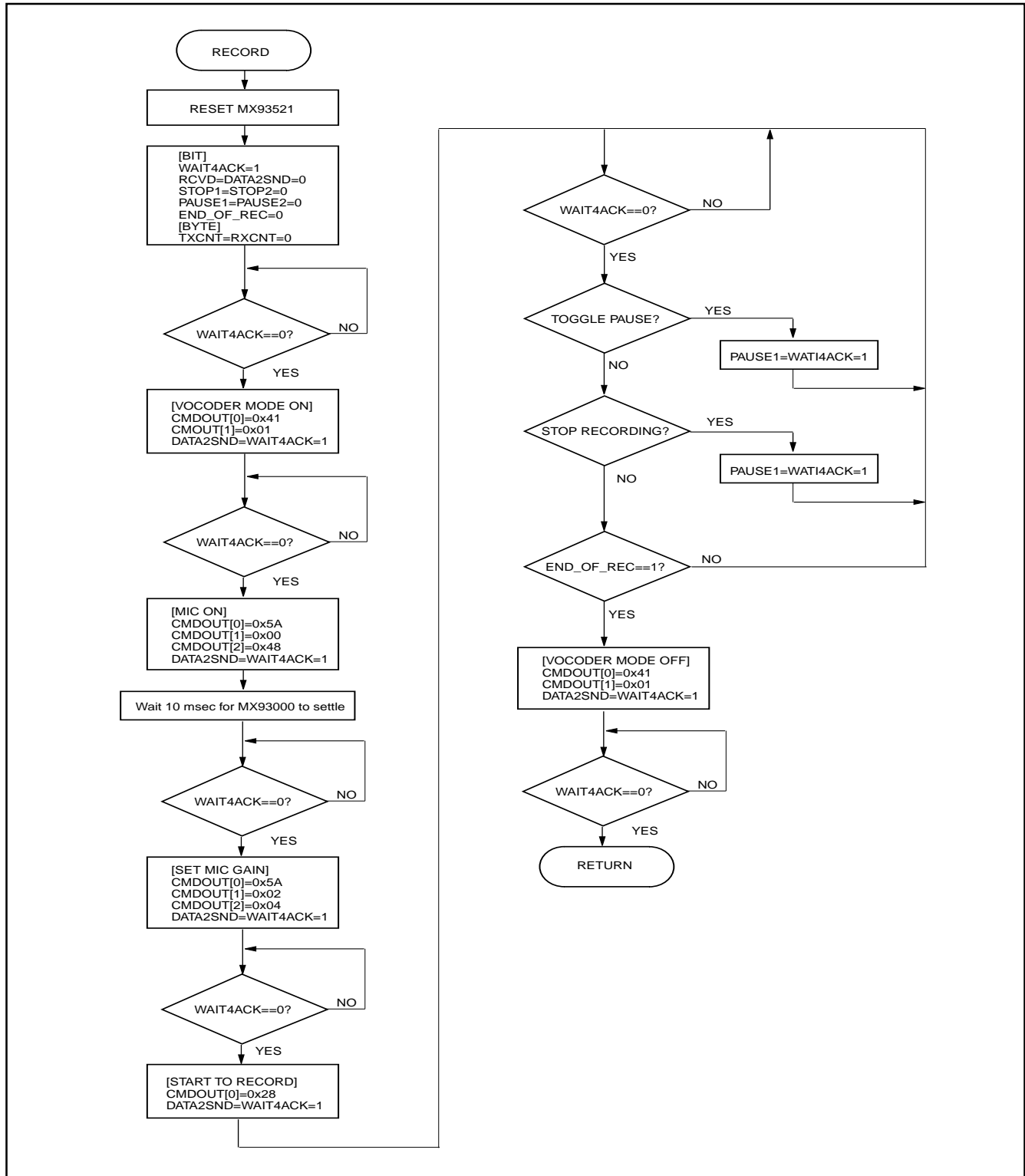
Appendix 4. Flow Chart of using MX93521 in VOCODER mode (Parallel Interface)
A4.1 Record mode (Background)

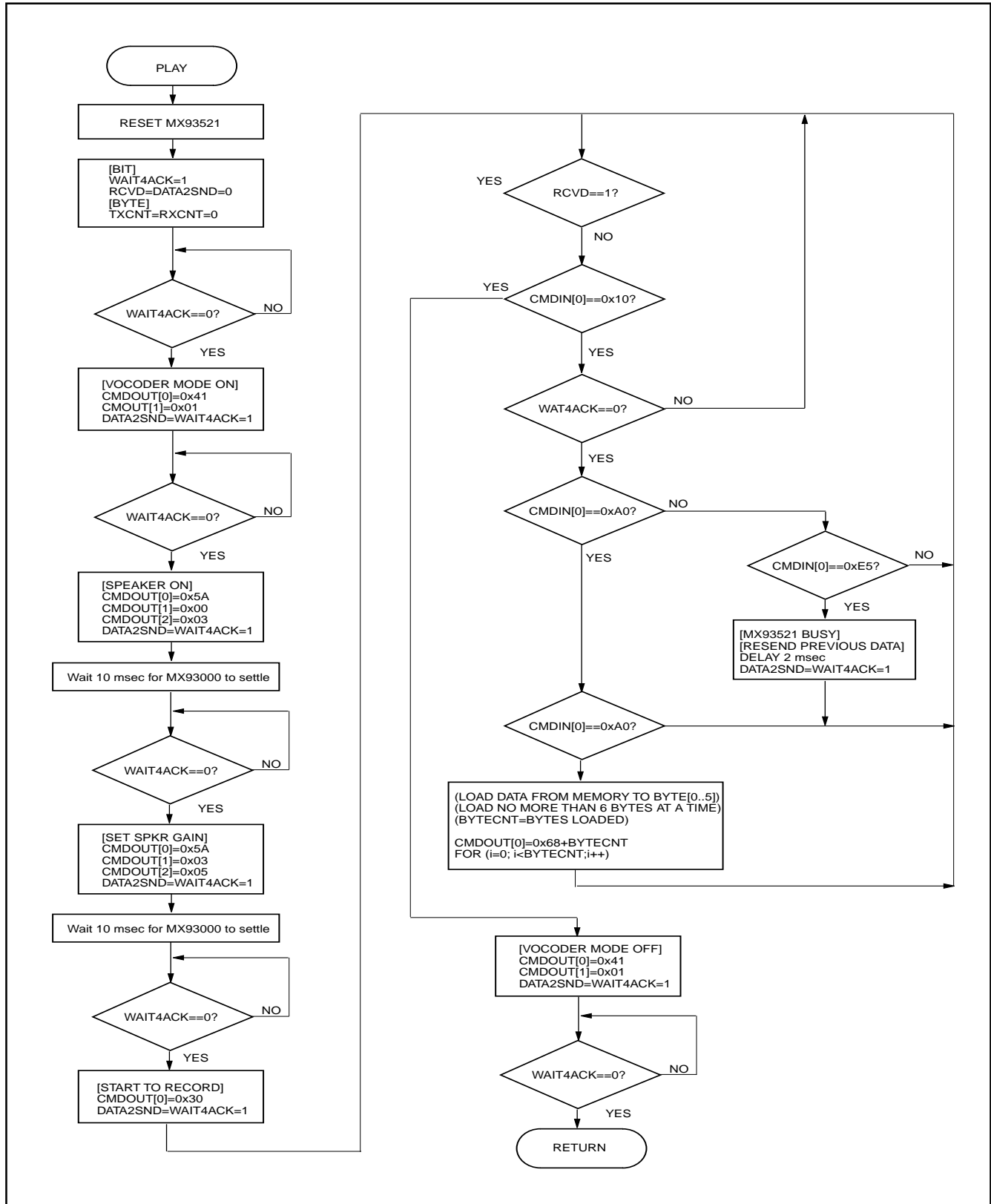
A4.2 Play mode (Background)

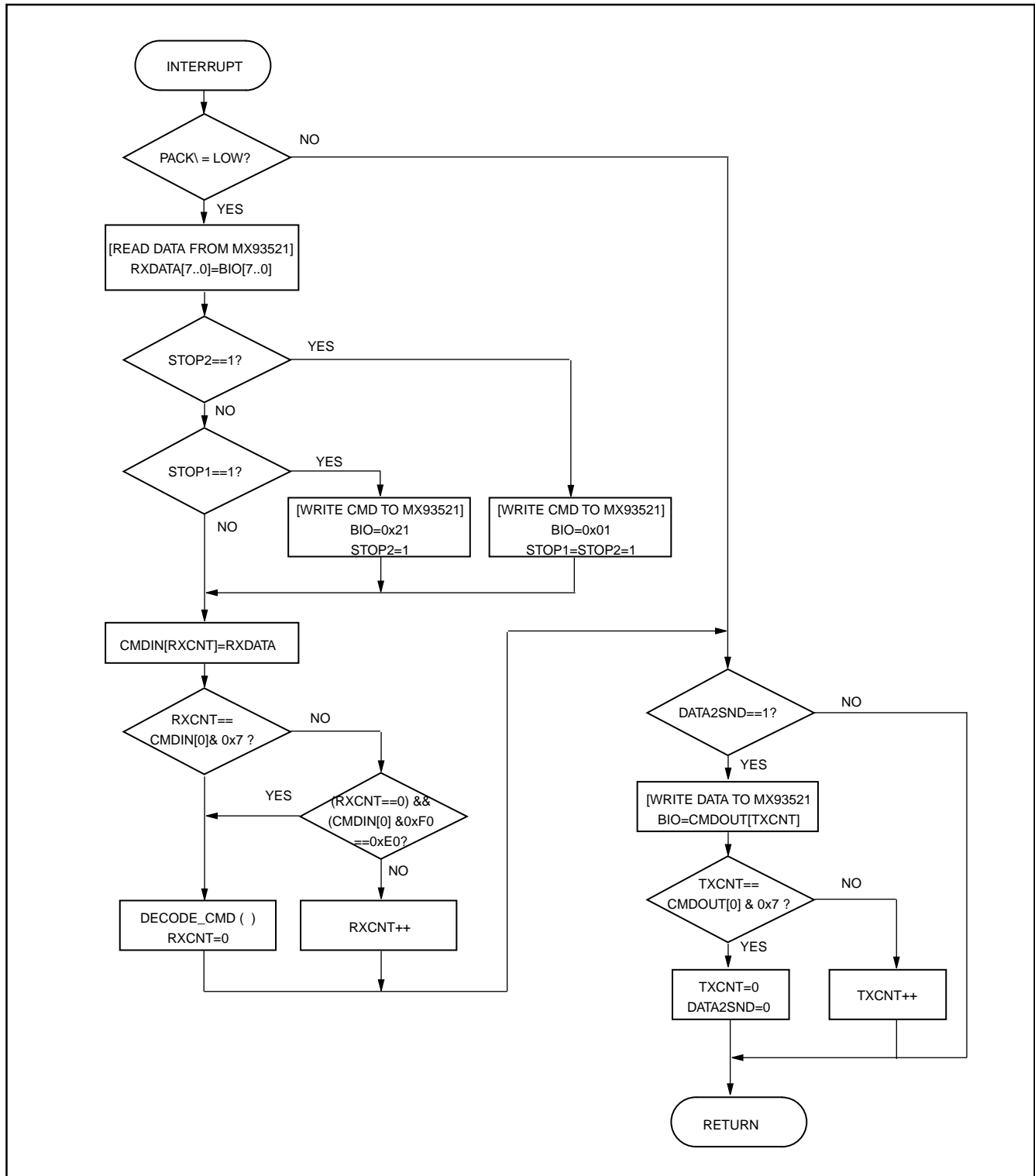
A4.3 Command/Data Send/Receive Handling Routine (Interrupt)

A4.4 Received Command Interpretation Routine (Interrupt)

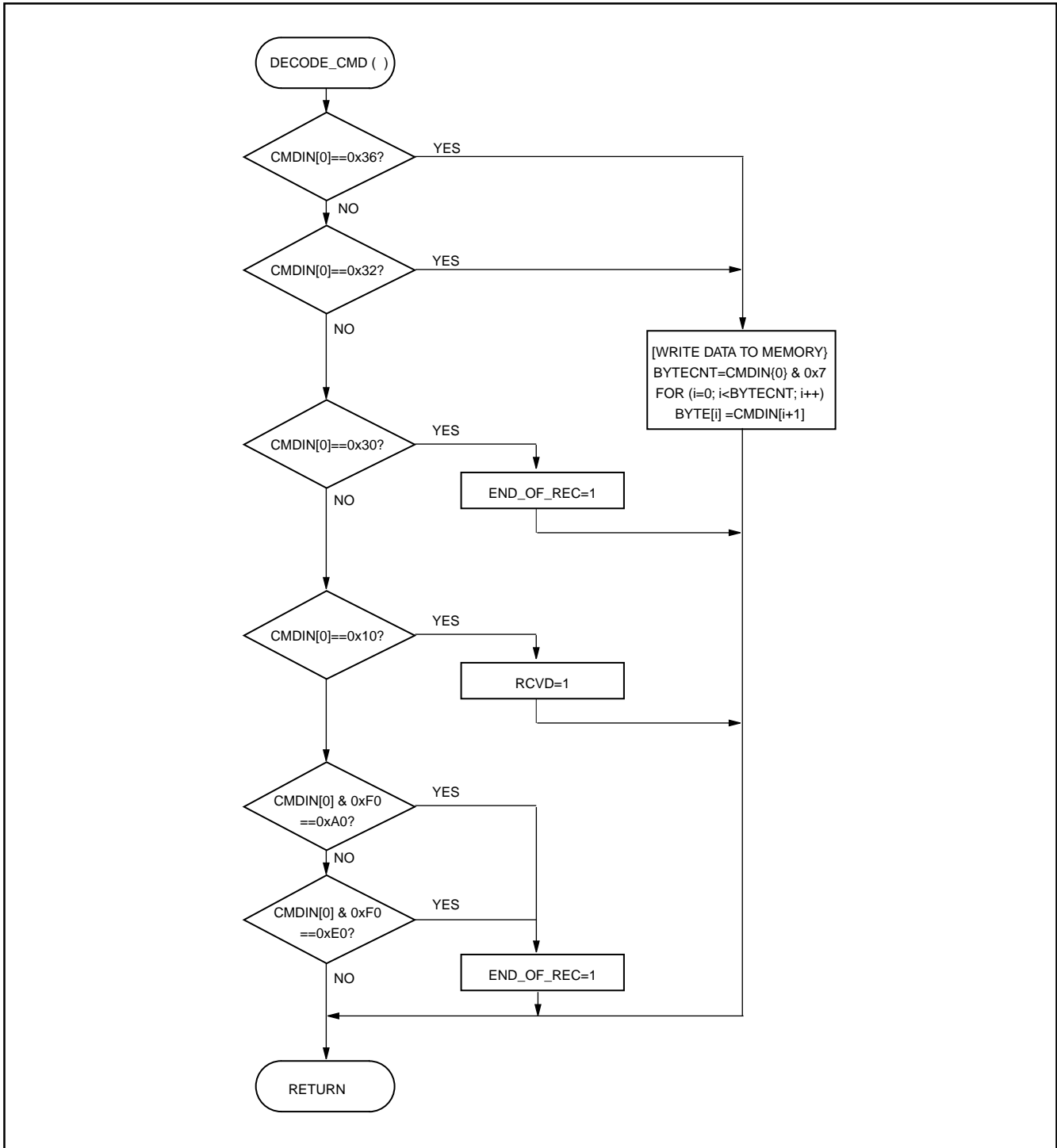



MX93521

MACRONIX INTERNATIONAL Co., LTD.

HEADQUARTERS:

TEL:+886-3-578-8888

FAX:+886-3-578-8887

EUROPE OFFICE:

TEL:+32-2-456-8020

FAX:+32-2-456-8021

JAPAN OFFICE:

TEL:+81-44-246-9100

FAX:+81-44-246-9105

SINGAPORE OFFICE:

TEL:+65-747-2309

FAX:+65-748-4090

TAIPEI OFFICE:

TEL:+886-3-509-3300

FAX:+886-3-509-2200

MACRONIX AMERICA, INC.

TEL:+1-408-453-8088

FAX:+1-408-453-8488

CHICAGO OFFICE:

TEL:+1-847-963-1900

FAX:+1-847-963-1909

[http : //www.macronix.com](http://www.macronix.com)
