



# MX97102

## ISDN S/T CONTROLLER

### FEATURES

- Pin-to-Pin and Register-to-Register compatible with Siemens 2186
- Full duplex 2B+D ISDN S/T Transceiver according to CCITT I.430
- GCI digital interface
- 3 types of 8-bit CPU interface
- Receive timing recovery with adaptively switched thresholds
- E-channel Monitoring

- Programmable SDS1, SDS2
- D-channel access control
- LAPD(HDLC) support with FIFO(2x64) buffers
- Activation/Deactivation
- Multiframe with S and Q bit access
- CPU access to B and IC channels
- Watchdog timer
- Package types : P-LCC-44, P-LQFP-64

### GENERAL DESCRIPTIONS

MX97102 implements the 4-wire S/T interface used to link voice/data terminals to an ISDN. It is designed for the user site of the ISDN-basic access, two 64kbit/s B channels and a 16kbit/s D channel.

multiframe S and Q channels, and D-channel access and priority control for communicating with remote equipments.

MX97102 can be mainly divided into three portions according to their interfaces. Except these three interface functions, it also provides the LAPD controller which handles the HDLC packets of the ISDN D-channel for the associated microprocessor.

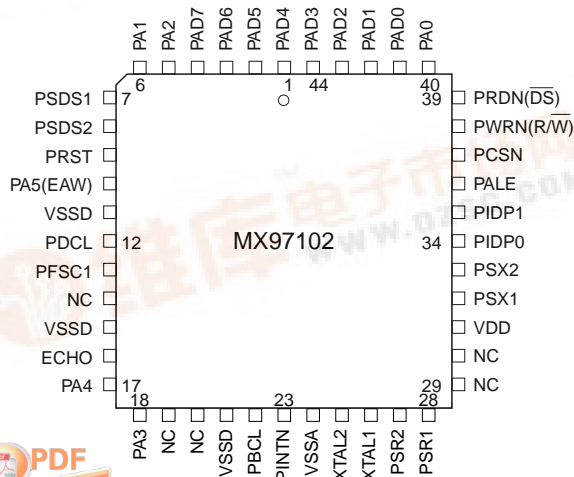
The Second is the microprocessor interface controller which offers the registers compatible with Siemens PSB2186, provides three types of microprocessor interface, such as Motorola bus mode, Intel multiplexed mode and Intel non-multiplexed mode.

The first, S/T interface controller, provides all electrical and logical functions of the S/T interface, such as S/T transceiver, activation/deactivation, timing recovery,

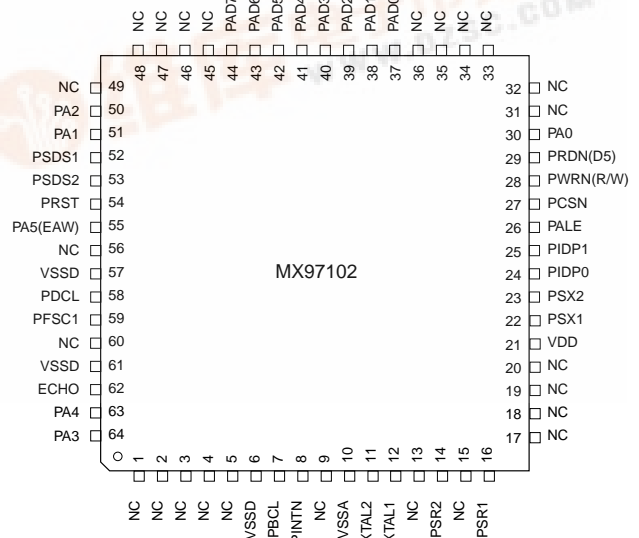
The last portion is the GCI interface controller which is used to connect different voice/data application modules for local digital data exchangements.

### PIN CONFIGURATION

#### 44-PLCC



#### 64-PLQFP



BLOCK DIAGRAM

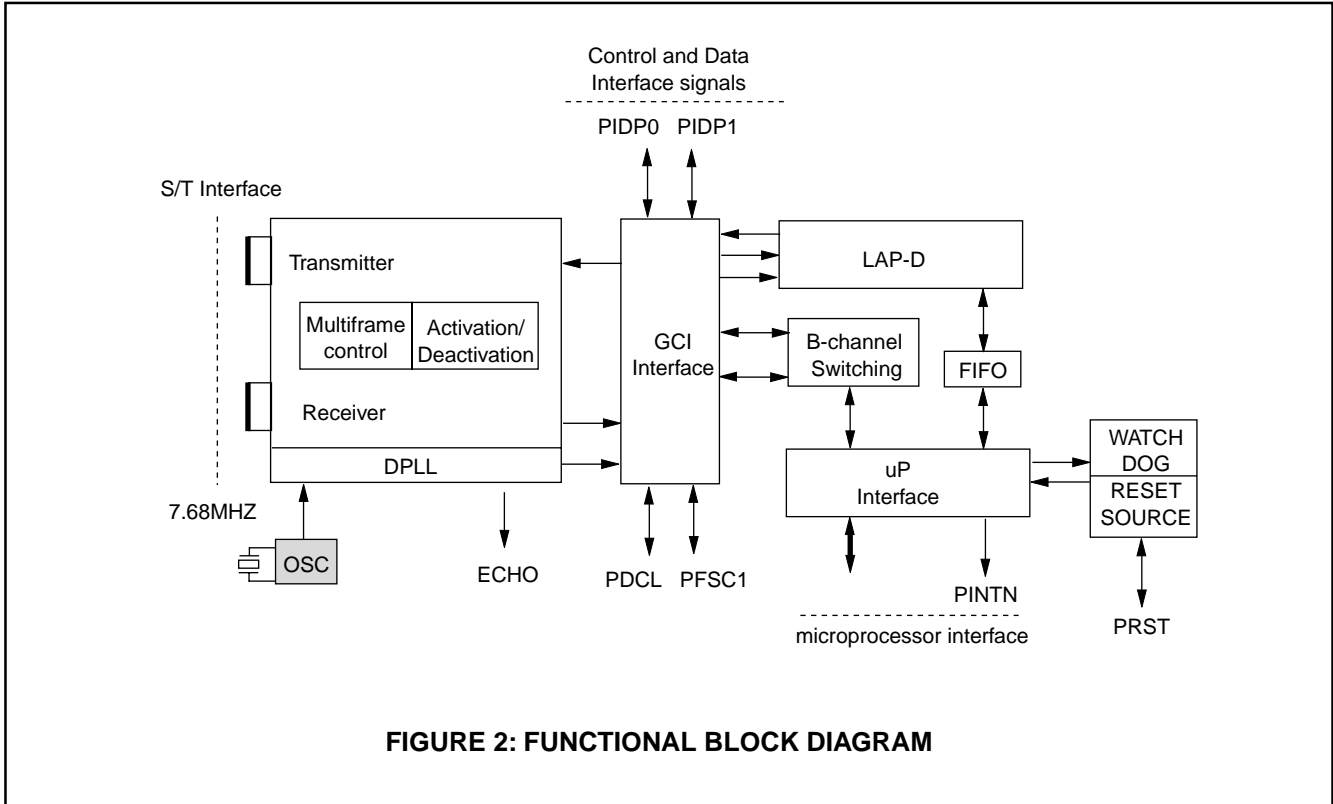


FIGURE 2: FUNCTIONAL BLOCK DIAGRAM



**PIN DESCRIPTION (44-PIN)**

**TABLE 1: MX97102 PIN DESCRIPTIONS**

LQFP	PLCC			
PAD#	PAD#	PIN NAME	I/O	DESCRIPTION
37	41	PAD0(D0)		Multiplexed Bus Mode:Address/data bus from the CPU system to this device
38	42	PAD1(D1)		,and data between the CPU system and this device.
39	43	PAD2(D2)		Non-Multiplexed Bus Mode:Data bus between the CPU system and this
40	44	PAD3(D3)	I/O	device.
41	1	PAD4(D4)		
42	2	PAD5(D5)		
43	3	PAD6(D6)		
44	4	PAD7(D7)		
27	37	PCSN	I	ChipSelect:A logic "LOW" enable this device for a read/write operation.
28	38	PWRN( $\bar{R}/\bar{W}$ )	I	Read/Write:A logic "HIGH" indicates a valid read operation by CPU. A logic "LOW" indicates a valid write operation by CPU.(Motorola bus mode) Write:A logic "LOW" indicates a write operation.(Intel bus mode)
29	39	PRDN( $\bar{DS}$ )	I	Data Strobe: The rising edge marks the end of a valid read or write operation (Motorola bus mode). Read:A logic "LOW" indicates a read operation.(Intel bus mode)
8	23	PINTN		Open Interrupt Request:The signal is a logic "LOW" when this device requests an Drain interrupt. It is an open drain output.
1~5, 9,13,15 17~20 31~36 45~49 56,60	14 19,20 29,30	NC		No used.
26	36	PALE	I	Address Latch Enable:A logic "HIGH" indicates an address on the address/data bus(Multiplexed bus type only). ALE also selects the micro-processor interface type (multiplexed or non-multiplexed).
54	9	PRST	I/O	Reset:A logic "HIGH" on this input forces this device into reset state. The minimum pulse length is four DCL-clock periods or four ms. If the terminal specific functions are enabled,this device may also output a reset signal.
59	13	PFSC1	O(I)	Frame Sync 1:Frame sync output. Logic "HIGH" during channel 0 on the GCI interface. This pin becomes Input if Test Mode is programmed (register ADF1).
58	12	PDCL	O(I)	Data Clock:Clock of frequency, 1536kHz output, equals to twice the GCI data rate. This pin becomes Input if Test Mode is programmed (register ADF1)
62	16	ECHO	O	This pin output the Echo bit from the receiving line.



**TABLE 1: MX97102 PIN DESCRIPTIONS(Continued)**

LQFP	PLCC			
PAD#	PAD#	PIN NAME	I/O	DESCRIPTION
(non-multiplexed bus mode)				
30	40	PA0	I	Address Bit 0
51	6	PA1	I	Address Bit 1
50	5	PA2	I	Address Bit 2
64	18	PA3	I	Address Bit 3
63	17	PA4	I	Address Bit 4
55	10	PA5(EAW)	I	Address Bit 5; External Awake, when terminal specific function enabled, this pin is used as an external awake line. If a falling edge on this input is detected, it generates an interrupt and a reset pulse.
7	22	PBCL	O	Bit Clock:Clock of frequency 768kHz equal to the GCI data rate.
52,53	7,8	PSDS1,2	O	Serial Data Strobe 1&2 : programmable strobe signals, selecting either one or two B or IC channels on GCI interface, is supplied via this line. (registers ADF2,4)
6,57,61	11, 15			
	21	VSSD	-	Digital ground
10	24	VSSA	-	Analog ground
21	31	VDD	-	Power supply (5V±5%)
12	26	PXTAL1	I	Connection for crystal or external clock input.
11	25	PXTAL2	O	Connection for external crystal. Left unconnected if external clock is used.
14	27	PSR2		
16	28	PSR1	I	S-Bus Receiver Input
22	32	PSX1		S-Bus Transmitter Output(positive)
23	33	PSX2	O	S-Bus Transmitter Output(negative)
24	34	PIDP0(DD)		GCI-Data Port 0 (DD)
25	35	PIDP1(DU)	I/O	GCI-Data Port 1 (DU) Open drain without internal pull-up resistor or push-pull.

**ABSOLUTE MAXIMUM RATINGS**

**TABLE 2: ABSOLUTE MAXIMUM RATINGS**

RATING	VALUE
Maximum Supply Voltage (VDD)	6V
DC Input Voltage on any pin	-0.4Vto VDD+0.4V
Storage Temperature Range	-55°C to 150°C
Operating Free Air Temperature Range	0°C to 70°C

**DC CHARACTERISTICS**
**TABLE 3: DC CHARACTERISTICS**

Temperature from 0 to 70°C; VDD = 5V±5%, VSSA = 0V, VSSD = 0V

Symbol	Parameter	Conditions	Min. Value	Max. Value	Unit	Remarks
VIL	L-input voltage		-0.4	0.8	V	
VIH	H-input voltage		2.0	VDD+0.4	V	All pins except
VOL	L-output voltage	IOL= 2mA		0.45	V	PSX1, PSX2,
VOL1	L-output voltage (IDP0)	IOL= 7mA		0.45	V	PSR1, PSR2
VOH	H-output voltage	IOH= -400uA	2.4		V	
VOH	H-output voltage	IOH= -100uA		VDD-0.75	V	
ILI	Input leakage current	0<VIN<VDD to 0V		±10		All pins except BCL, PSX1,2,
ILO	Output leakage current	0<VOUT<VDD to 0V		±10	uA	PSR1,2, PA0, PA1, PA3, PA4
ILIPD	Input leakage current, internal pull-down	0<VIN<VDD to 0V		120	uA	PA0, PA1, PA3, PA4, BCL
VX	Absolute value of output pulse amplitude (VSX2 - VSX1)	RL = 50ohm RL = 400ohm	2.03 2.35	2.31 2.65	V	PSX1, PSX2
IX	Transmitter out- put current	RL = 5.6ohm	7.5	13.4	mA	
RX	Transmitter out- put impedance	Inactive or during binary one during binary zero RL = 50ohm	10 0	kohm ohm		
VSR1	Receiver output voltage	IO < 5uA	2.35	2.63	V	PSR1, PSR2
VTR	Receiver threshold voltage (VSR2 - VSR1)	Dependent on peak level	225	375	mV	

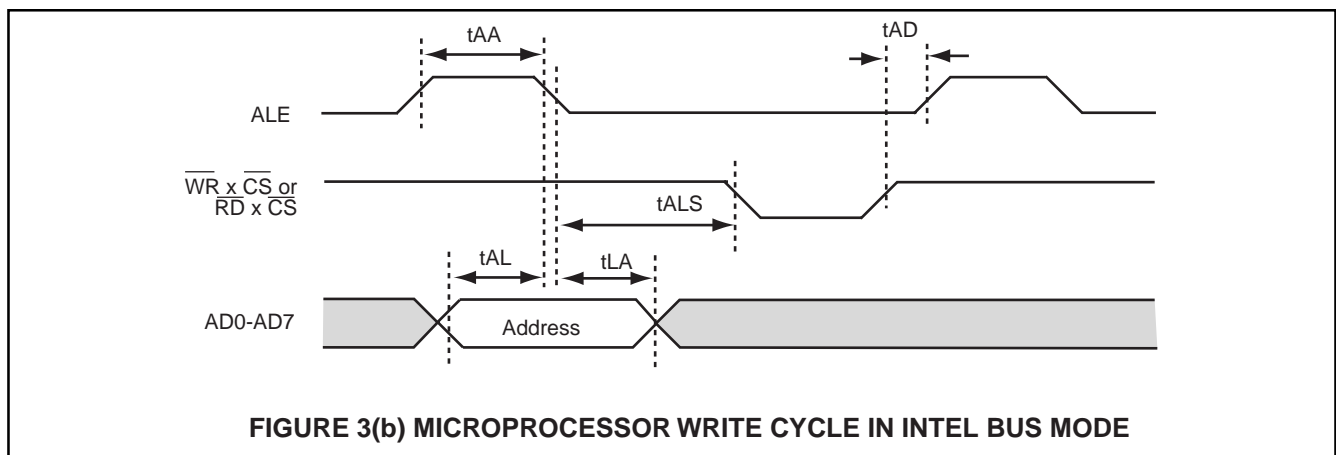
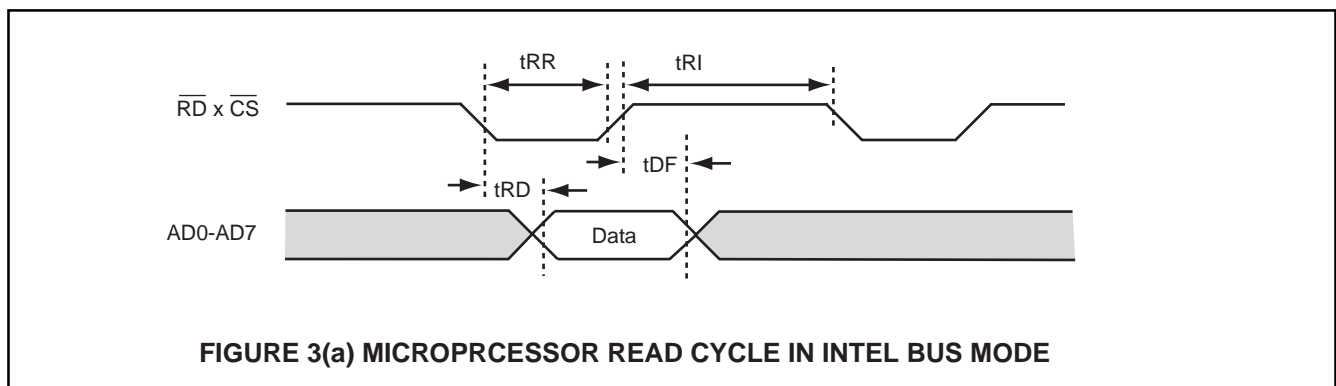
**AC CHARACTERICS**
**TABLE 4: CRYSTAL SPECIFICATION**

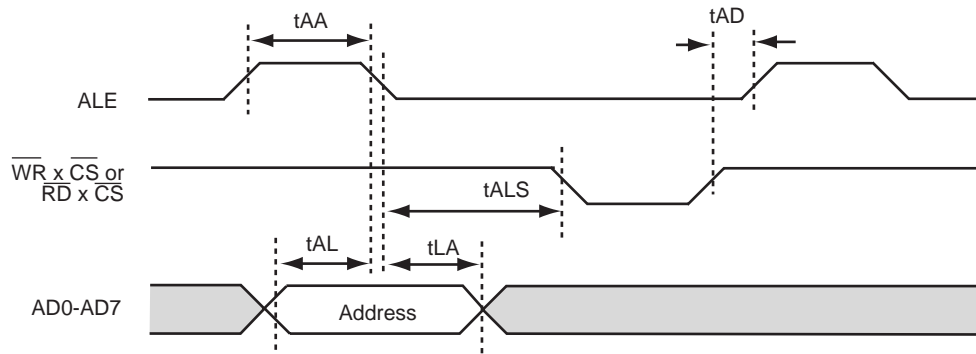
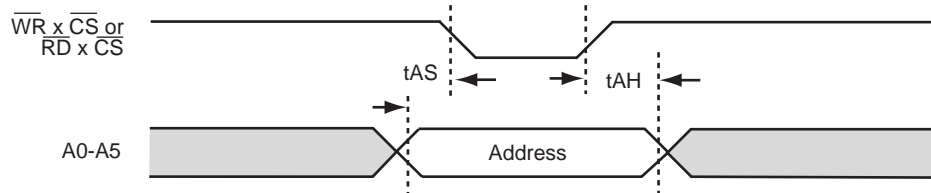
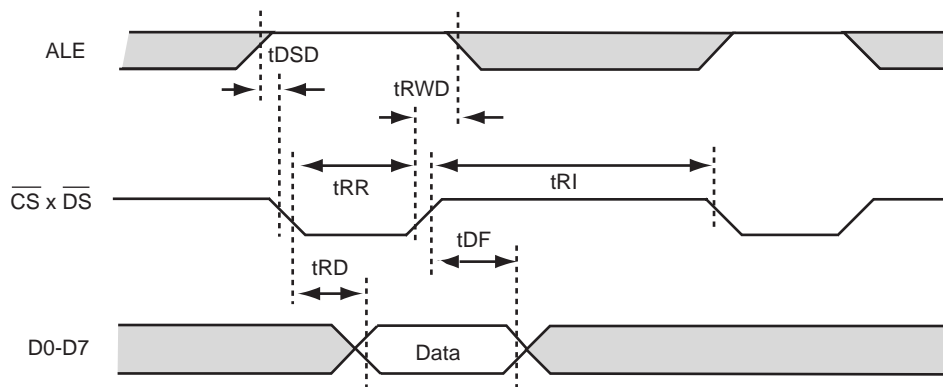
PARAMETER	SYMBOL	Limit values	UNIT
Frequency	f	7.680	MHz
Frequency calibration tolerance		max. 100	ppm
Load capacitance	CL	max. 50	pF
Oscillator mode		fundamental	

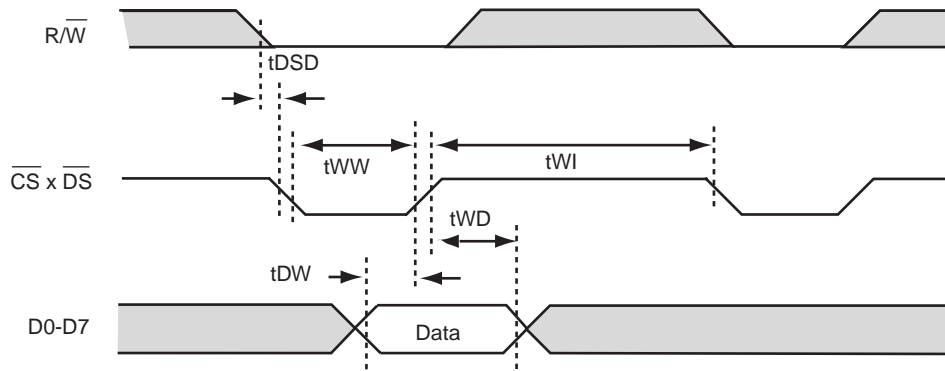
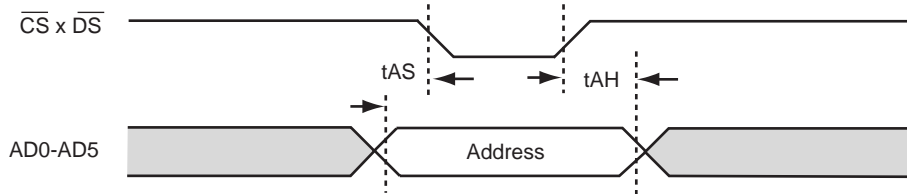
**XTAL1 Clock Characteristics (external oscillator input)**
**TABLE 5: CLOCK CHARACTERISTICS**

Parameter	Limit values	
	min.	max.
Duty cycle	1:2	2:1

Temperature from 0 to 70°C, VDD = 5V±5%  
 Inputs are driven to 2.4V for a logical "1" and to 0.4V for a logical "0". Timing measurements are made at 2.0V for a logical "1" and 0.8V for a logical "0". The AC-testing output is loaded with a 150pF capacitor.

**TIMING WAVE FORM**
**MICROPROCESSOR INTERFACE TIMING----INTERL BUS MODE**



**FIGURE 3(c) MULTIPLEXED ADDRESS TIMING IN INTEL BUS MODE**

**FIGURE 3(d) NON-MULTIPLEXED ADDRESS TIMING IN INTEL BUS MODE**
**MOTOROLA BUS MODE**

**FIGURE 4(a) MICROPROCESSOR READ TIMING IN MOTOROLA BUS MODE**


**FIGURE 4(b) MICROPROCESSOR WRITE TIMING IN MOTOROLA BUS MODE**

**FIGURE 4(c) NON-MULTIPLEXED ADDRESS TIMING IN MOTOROLA BUS MODE**
**TABLE 6: PARAMETERS FOR MICROPROCESSOR INTERFACE TIMING**

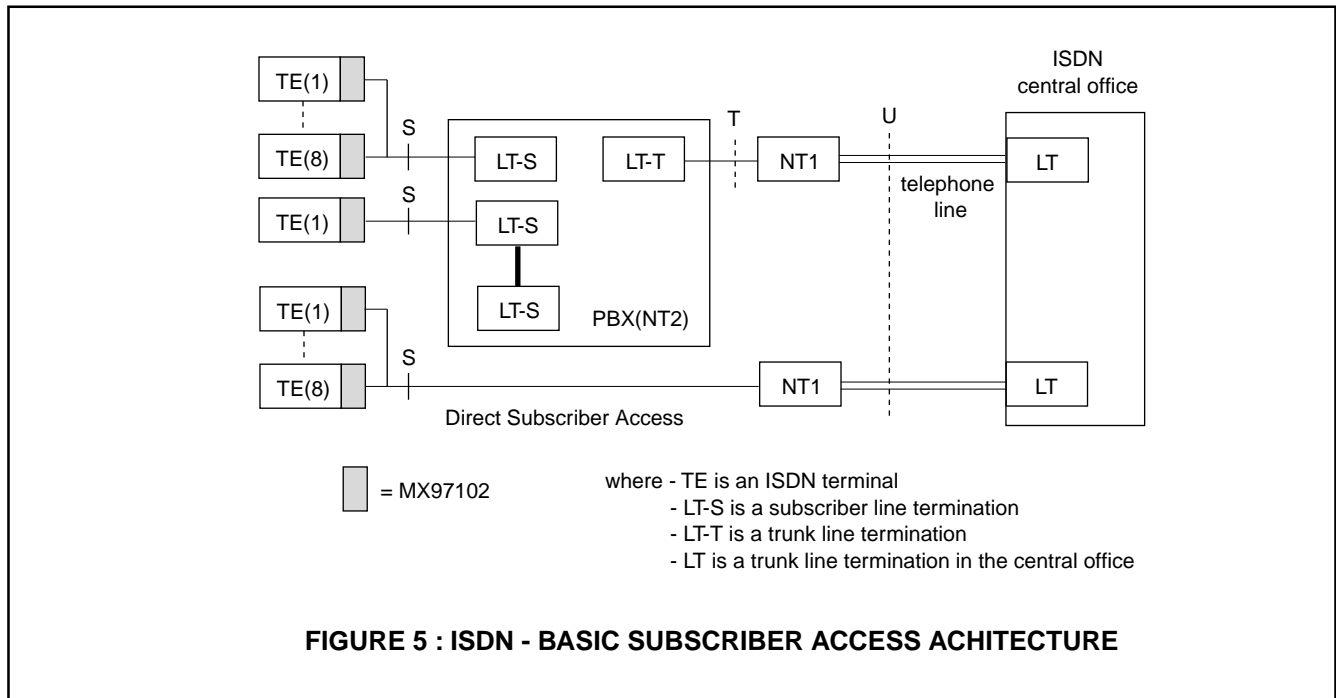
PARAMETER	SYMBOL	Limit Value		UNIT
		min.	max.	
ALE pulse width	tAA	40		ns
Address setup time to ALE	tAL	10		ns
Address hold time to ALE	tLA	10		ns
Address latch setup time to $\overline{WR}$ , $\overline{RD}$	tALS	0		ns
Address setup time	tAS	10		ns
Address hold time	tAH	10		ns
ALE guard time	tAD	15		ns
$\overline{DS}$ delay after $\overline{RW}$ setup	tDSD	0		ns
$\overline{RD}$ pulse width	tRR	50		ns
Data output delay from $\overline{RD}$	tRD		50	ns
Data float from $\overline{RD}$	tDF		52	ns
$\overline{RD}$ control interval	tRI	50		ns
$\overline{W}$ pulse width	tWW	50		ns
Data setup time to $\overline{W}$ , CS	tDW	10		ns
Data hold time from $\overline{W}$ , CS	tWD	10		ns
$\overline{W}$ control interval	tWI	50		ns



**Functional and Operational Description**
**ISDN ACCESS ARCHITECTURE**

MX97102 is designed especially for subscriber terminal equipment with S/T interfaces, Four wire, two pairs for transmission and reception separately, are connected to the NT equipment at the user site. Via the NT equipment, subscribers could dial up to the wide-area network with the traditional telephone line. The NT serves a converter between the U interface at the ex-

change and the S interface at the user premises. The NT may be either an NT1 only or an NT1 together with an NT2 connected via the T interface which is physically identical to the S interface. NT2 may include higher level functions like multiplexing and switching as in a PBX. Figure 5 illustrates the connections between the user site to the public domain of central office.



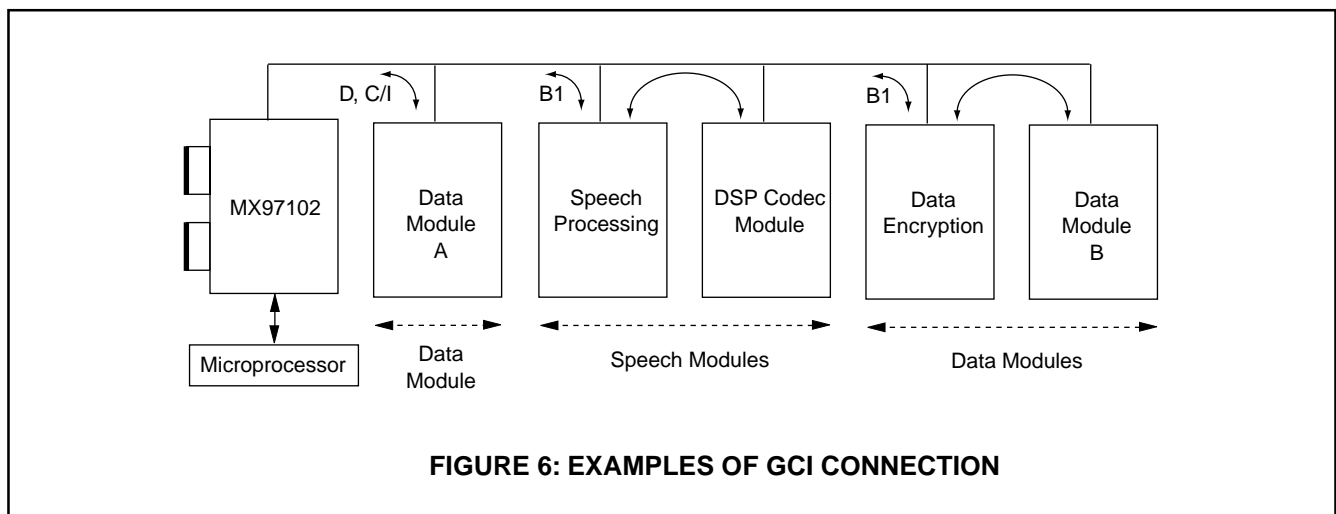
MX97102 is based on the ISDN basic access, 192kbit/s, which consists of two circuit-switched 64 kbit/s B channels and a message oriented 16kbit/s D channel for packetized data, signaling and telemetry information. The D channel is processed by the LAPD controller contained in the MX97102 and routed via a parallel CPU interface to the terminal processor. The high level support of the LAPD protocol which is implemented by the MX97102 allows the use of a low cost processor in cost sensitive applications.

**GCI CONNECTION**

With the GCI interface, MX97102 could connect different voice/data (V/D) application modules. Up to eight D-channel components may be connected to the D and C/I (Command/Indication) channels (TIC-bus). TIC-bus arbitration is also implemented in MX97102.

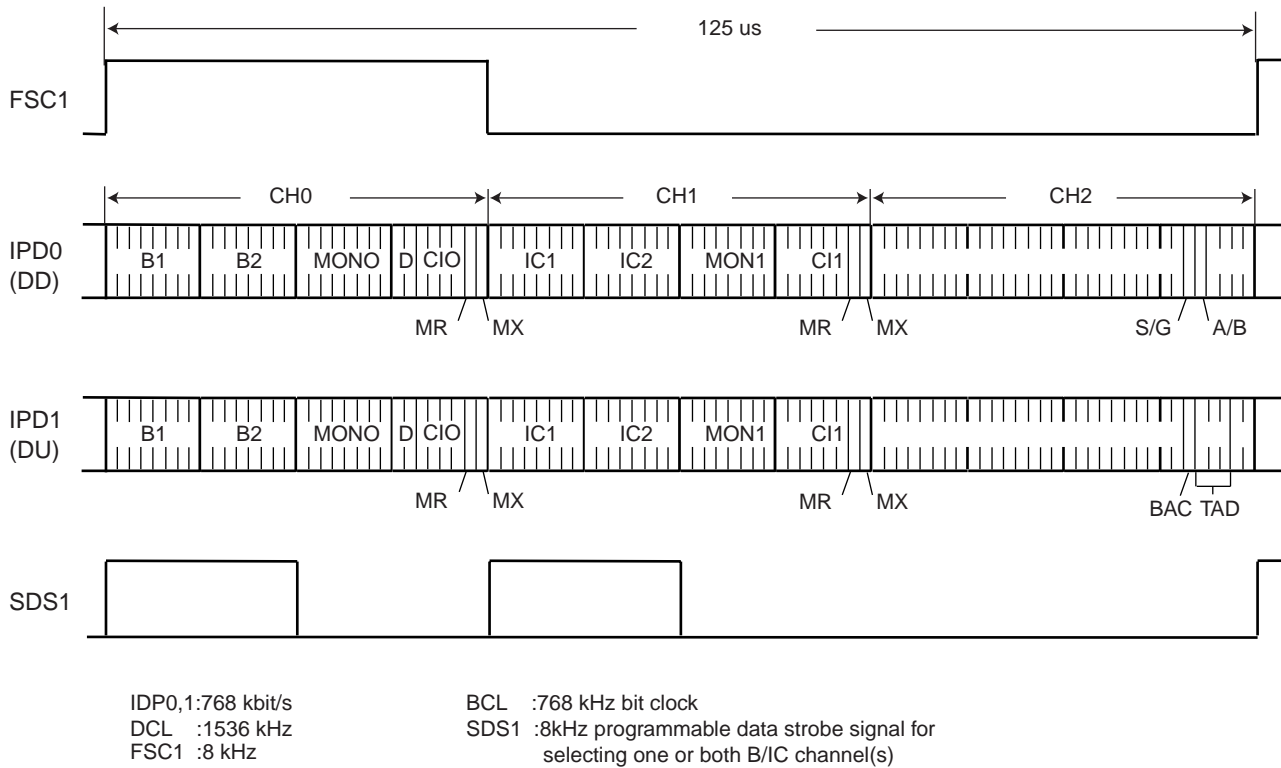
Data transfers between the MX97102 and the V/D modules are done with the help of the GCI MONITOR channel protocol. Each V/D module can be accessed by an

individual address. Two intercommunication channels IC1 and IC2 allow a 2\*64kbit/s transfer rate between voice/data modules. Figure 6 shows one GCI connection, data module A uses D-channel for data transfer, a voice processor is connected to a programmable digital processing codec filter via IC1 and a data encryption module to a data device via IC2. Meanwhile, B1 is used for voice communication, B2 for data communication.


**GCI FUNCTIONS**

In terminal applications, the GCI constitutes a powerful backplane bus offering intercommunication and sophisticated control capabilities for peripheral modules. GCI frame is composed of three channels ( see Figure 6-1 below):

- Channel 0 contains 144kbit/s (for 2B+D) plus MONITOR and command/indication channels for the layer-1 device.
- Channel 1 contains two 64kbit/s intercommunication channels plus MONITOR and command/indication channels for other GCI devices.
- Channel 2 is used for GCI-bus arbitration. Only the command/indication are used in channel 2.



**Figure 6-1 Frame structure of GCI**

The GCI interface is operated in the “open drain” mode in order to take advantage of the bus capability. In this case pull-up resistors (1kohm-5kohm) are required on PIDP0 and PIDP1.

**GCI OFF Function**

In GCI terminal mode (SPCR:SPM=0) the GCI interface can be switched off for external devices via IOF bit in ADF1 register. If IOF=1, the interface is switched off. Thus, DCL, FSC1, IDP0/1 and BCL are high impedance.

**GCI Direction Control**

For test applications, the direction of IDP0 (DD) and IDP1 (DU) can be reversed during certain time-slots within the GCI frame. This is performed via the IDC bit in the SQXR register. For normal operation SQXR:IDC should be set to “0”.

GCI has the 12-byte frame structure consisting of channels 0, 1 and 2. (see figure 6-1 above)

- IDP0 carries the 2B+D channels from the S/T interface, and the MONITOR 0 and C/I 0 channels coming from the S/T controller;
- IDP1 carries the MONITOR 0 and C/I 0 channels to the layer-1.

Channel 1 of GCI interface is used for internal communication in terminal applications. Two cases have to be distinguished, according to whether the MX97102 is operated as a master device or as a slave device.

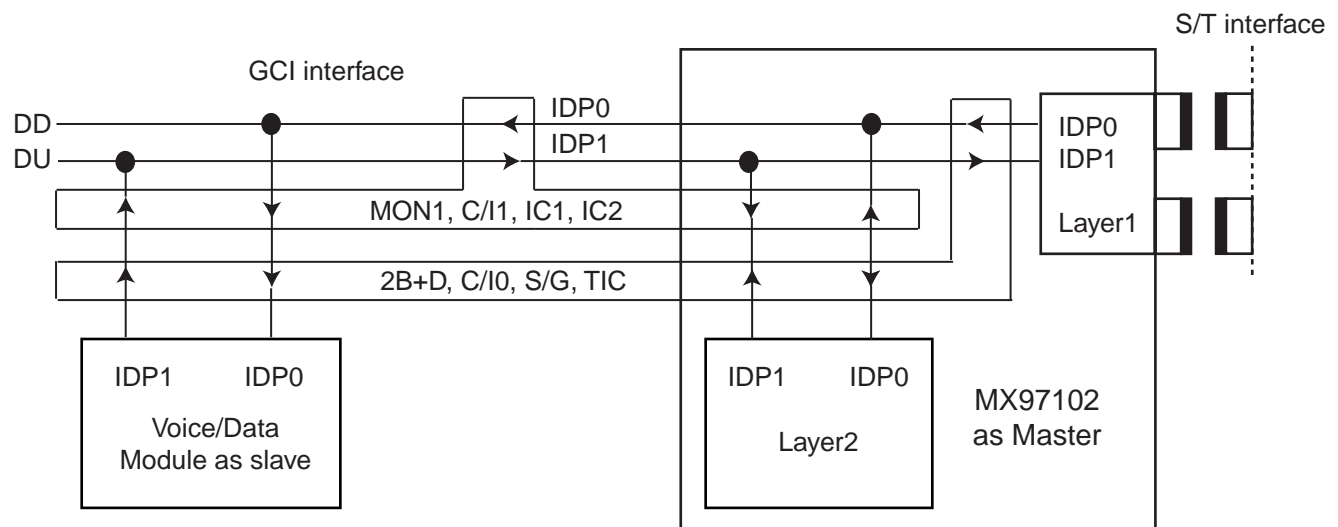
If IDC is set to "0" (master mode):

- IDP0 carries the MONITOR 1 and C/I 1 channels as output to peripheral (voice/data) devices;
- IDP0 also carries the IC channels as output to other devices, if programmed (Cx C1-0=01 in register SPCR).

If IDC is set to "1" (slave mode):

- IDP1 carries the MONITOR 1 and C/I 1 channels as output to a master device;
- IDP0 carries the IC channels as output to other devices, if programmed (Cx C1-0=01 in register SPCR).

Figure 6-2 shows the connection in a multifunctional terminal with the MX97102 as a master and a Voice/Data module as a slave device.



**Figure 6-2 GCI port connection and Data direction**

If GCI-0 of MODE register is programmed, bit 5 of the last byte in channel 2 on IDP0 can be used to indicate the S-bus state (stop/go bit) and bit 2 to 5 of the last byte are used for TIC-bus access arbitration.

**Microprocessor Access to B and IC Channels**

The microprocessor can access the B and IC channels at the GCI interface by reading the B1CR/B2CR or by reading and writing the C1R/C2R registers. Furthermore it is possible to loop back the B channels from/to the S/T interface or to loop back the IC channels from/to the GCI interface without CPU intervention.

Four different functions are selected by the bits CxC1 and CxC0 in the SPCR register. Moreover, each channel, B channel 0/1 and IC channel 0/1, is programmed individually. Table7-1 shows the configurations.

CxC1	CxC0	CxR Read	CxR Write	BxCR Read	Output to GCI	Applications
0	0	ICx	-	Bx	-	Bx, ICx monitoring
0	1	ICx	ICx	Bx	ICx	Bx monitoring, ICx looping from/to GCI
1	0	-	Bx	Bx	Bx	Bx access from/to S; transmission of a constant value in Bx channel to S
1	1	Bx	Bx	-	Bx	Bx looping from S; transmission of a variable pattern in Bx channels to S

Table 7-1 CPU access to B/IC channels by SPCR register

Note: x=1 for channel 1 or x=2 for channel 2

If the B-channel access is used for transferring 64kbit/s voice/data information directly from the CPU port to the ISDN S/T interface, the access can be synchronized to the GCI interface by means of a synchronous transfer interrupt programmed in the STCR register.

The general sequence of operations to access the B/IC channels is:

1. Program synchronous interrupt (ST0) which causes the device to generate an SIN interrupt at the beginning of an GCI frame.
2. Read or write register (BxCR, CxR)
3. Set SC0 bit in the STCR to acknowledge SIN interrupt.

repeat this sequence from 1 to 3.

Same procedure could be used at ST1 and SC1 bits in the STCR register. The only difference is ST1 generates an SIN interrupt at the middle of an GCI frame instead of at the beginning.

When CPU accesses B channels, we can set the IOF bit to switch off the GCI function. Thus, external B-channel sources (voice/data modules) can not disturb the B-channel access on the GCI interface.

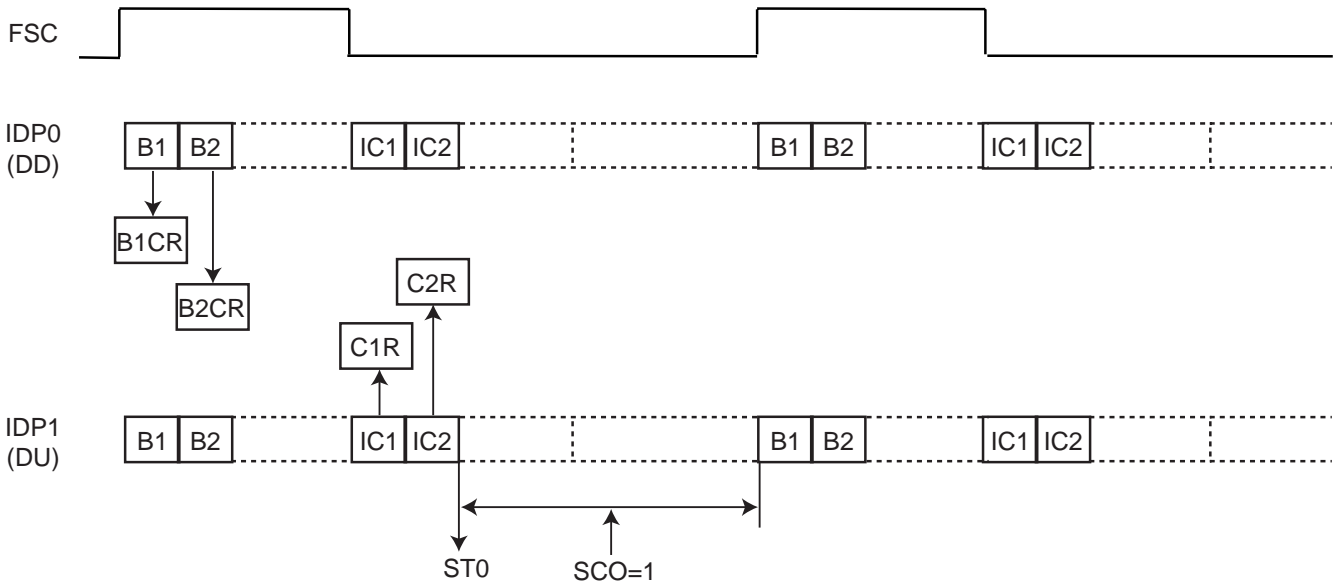
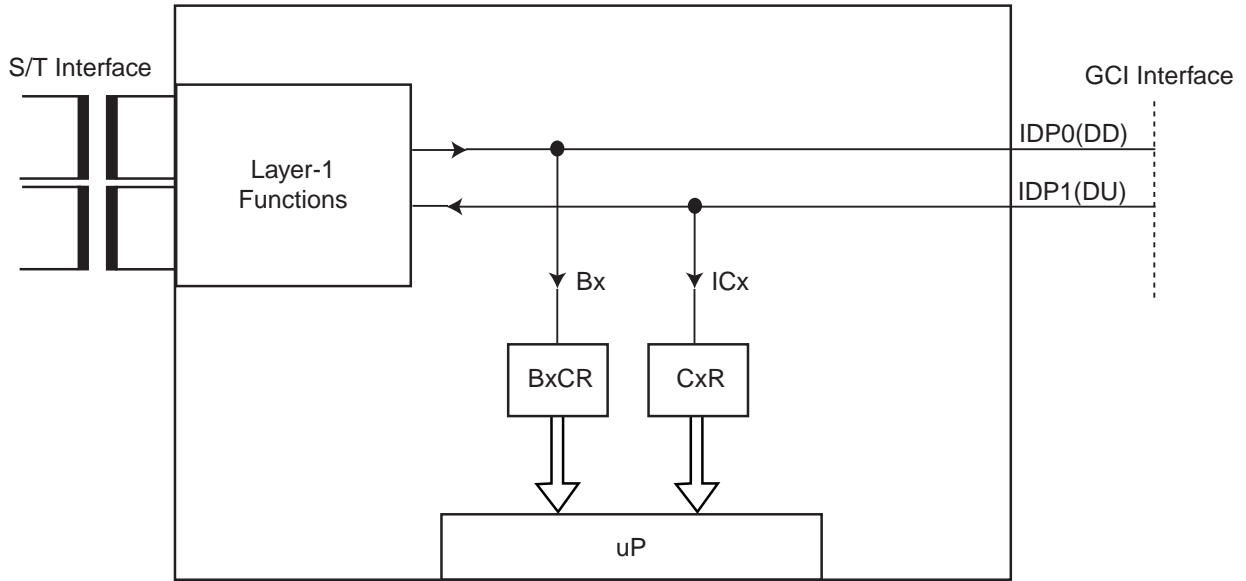
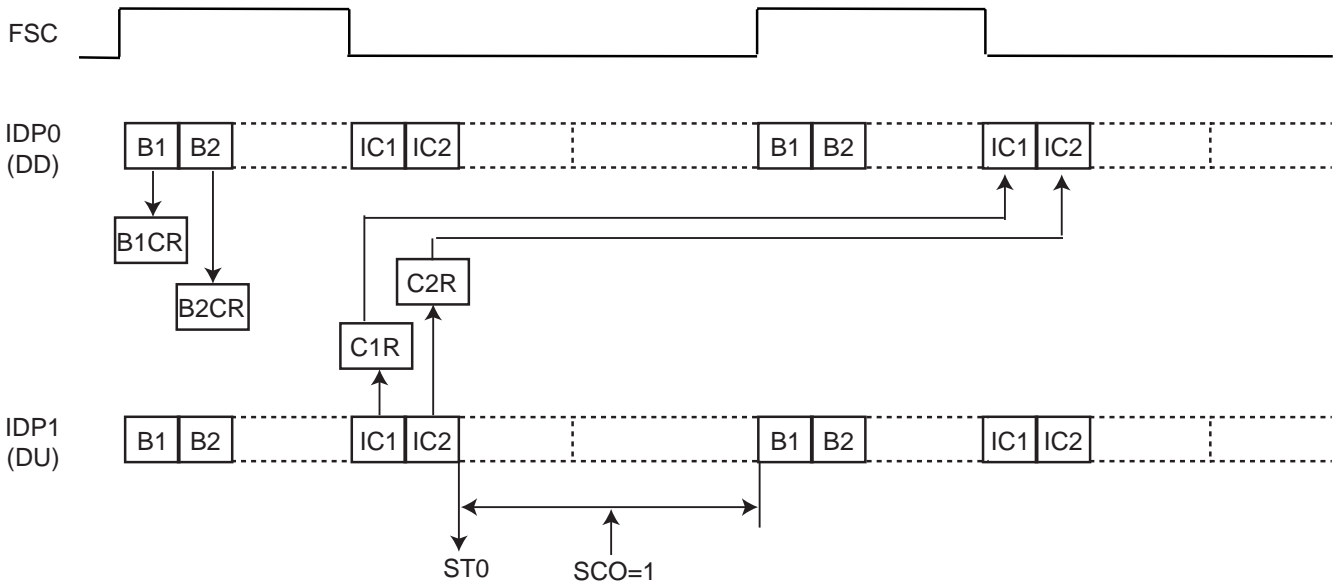
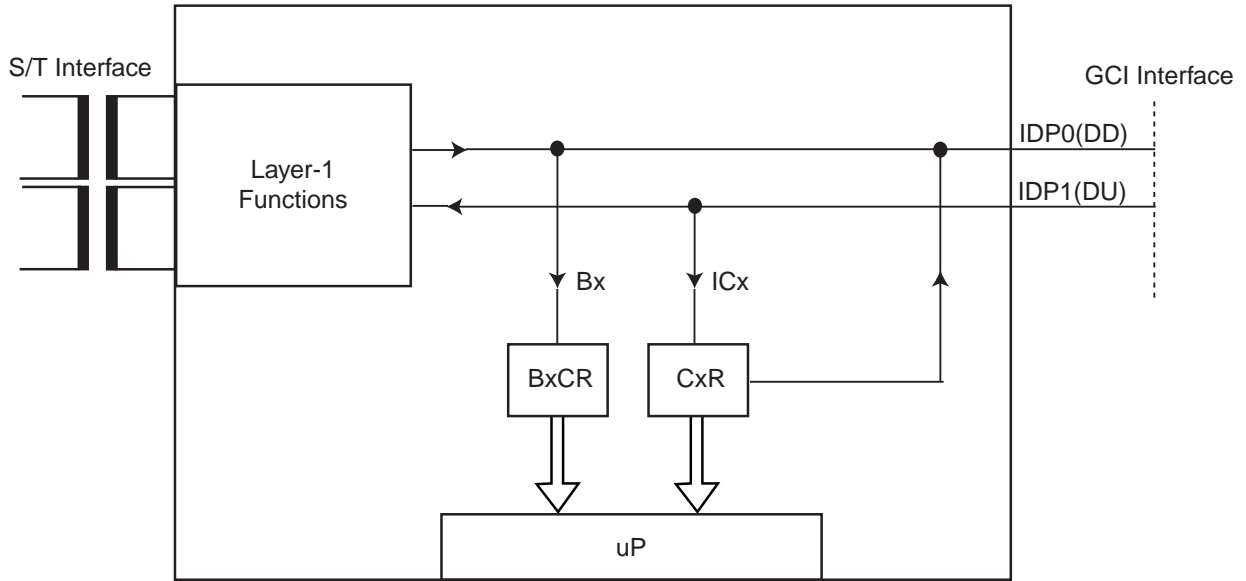
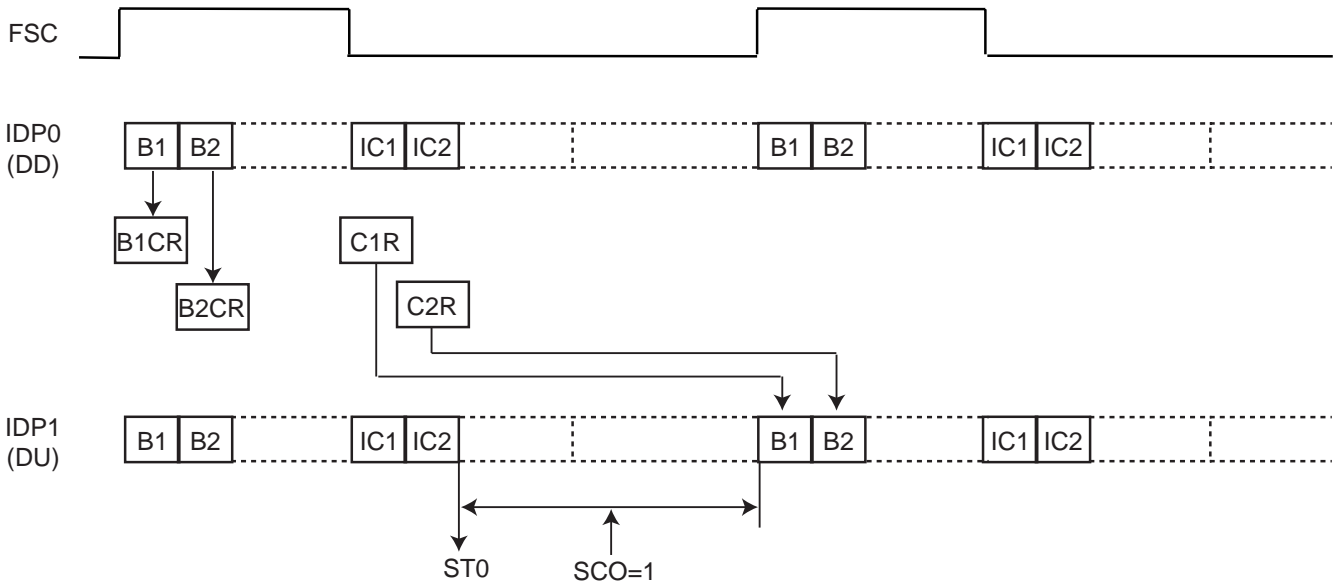
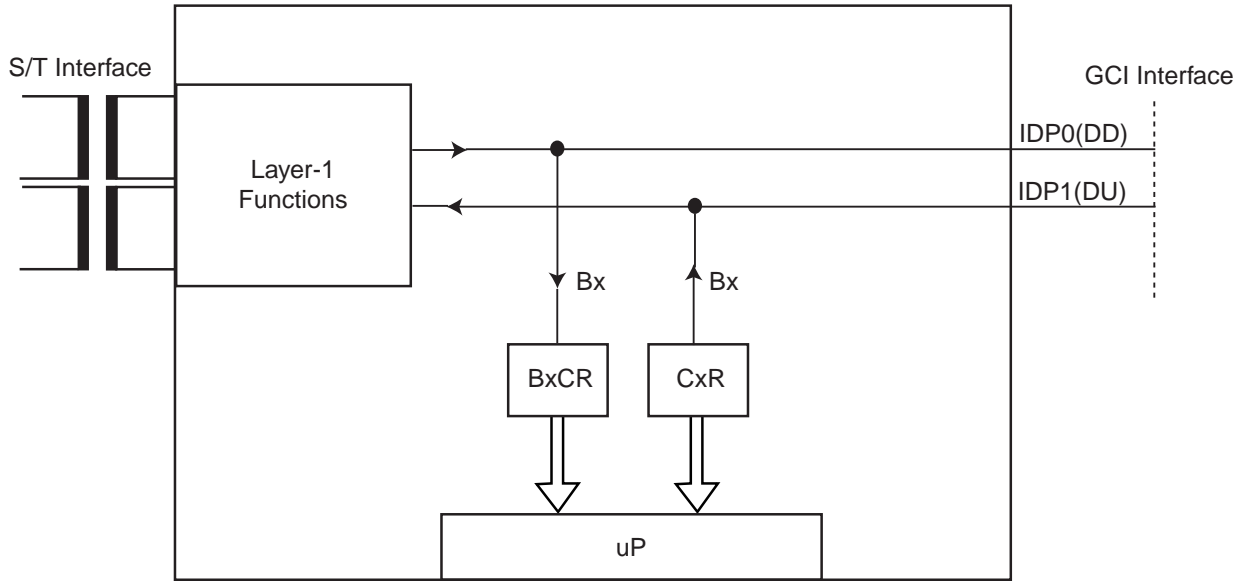


Figure 6-3(a) SPCR : (CxC1, CxC0) = (0,0) Bx and ICx monitoring

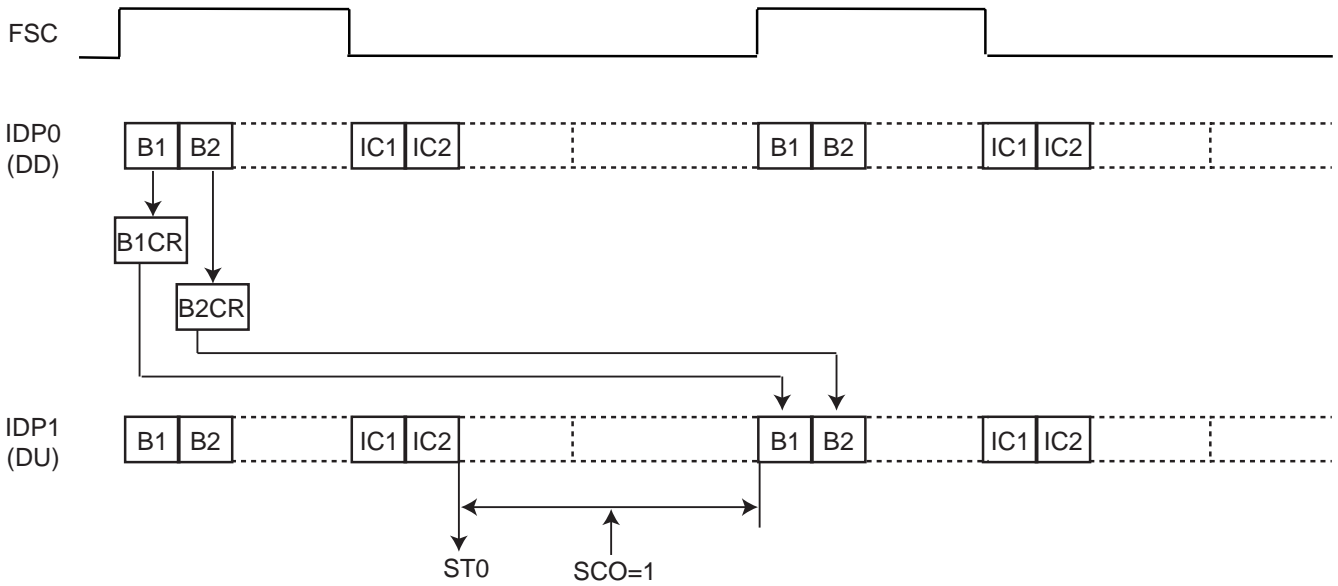
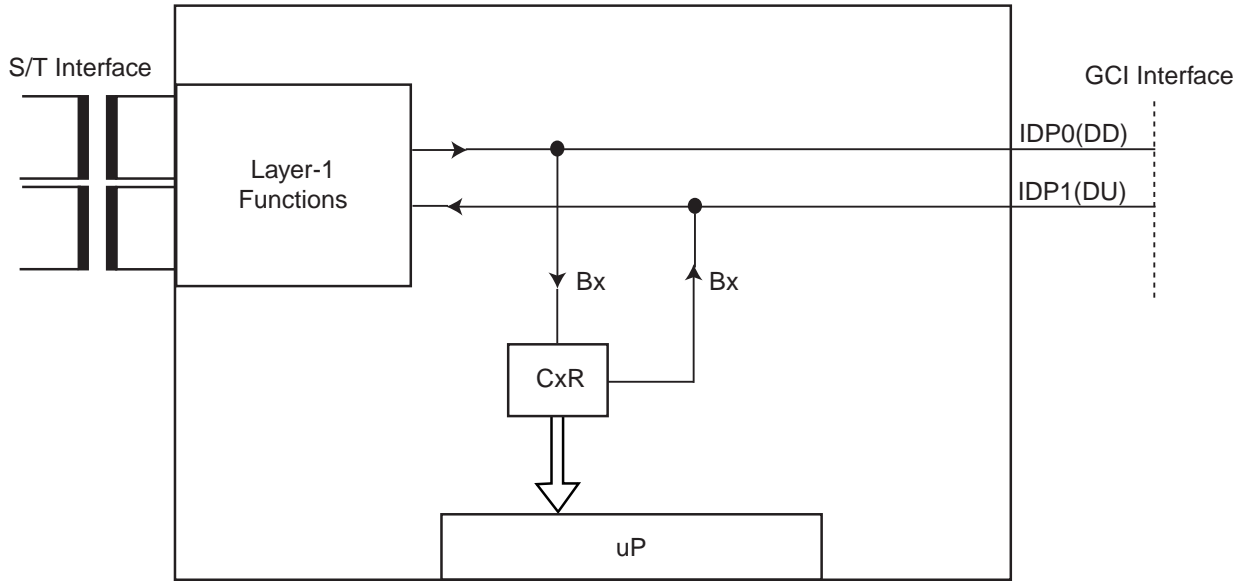


**Figure 6-3(b) SPCR : (Cx<sub>C1</sub>, Cx<sub>C0</sub>) = (0,0) Bx and ICx monitoring, ICx looping (SQXR : IDC = 0)**



**Figure 6-3(c) SPCR : (Cx<sub>C1</sub>, Cx<sub>C0</sub>) = (1,0) Bx access from/to S/T transmission of constant value of S/T**





**Figure 6-3(c) SPCR : (Cx<sub>C1</sub>, Cx<sub>C0</sub>) = (1,1) Bx looping from/to S/T transmission of variable pattern of S/T**

### MONITOR channel handling

The MONITOR channel protocol is a handshake protocol used for high speed information exchange between the MX97102 and other devices.

The usage of the MONITOR channel protocol (see Figure 6-4 below):

- For programming and controlling devices attached to the GCI. Examples of such devices are layer-1 transceivers (using MONITOR channel 0), and peripheral V/D modules that do not need a parallel microcontroller interface (by using MONITOR channel 1), such as the Audio Ringing Codec Filter.

- For data exchange between two microcontroller systems attached to two different devices on one GCI backplane. Use of the MONITOR channel avoids the necessity of a dedicated serial communication path between the two systems. This simplifies the system design of terminal equipments.

Note: MX97102 does not support the “MONITOR channel 0” operation. The implemented MONITOR handler can however be used with external layer-1 transceivers in case only the ICC part of this device is used (ADF1: TEM, PFS).

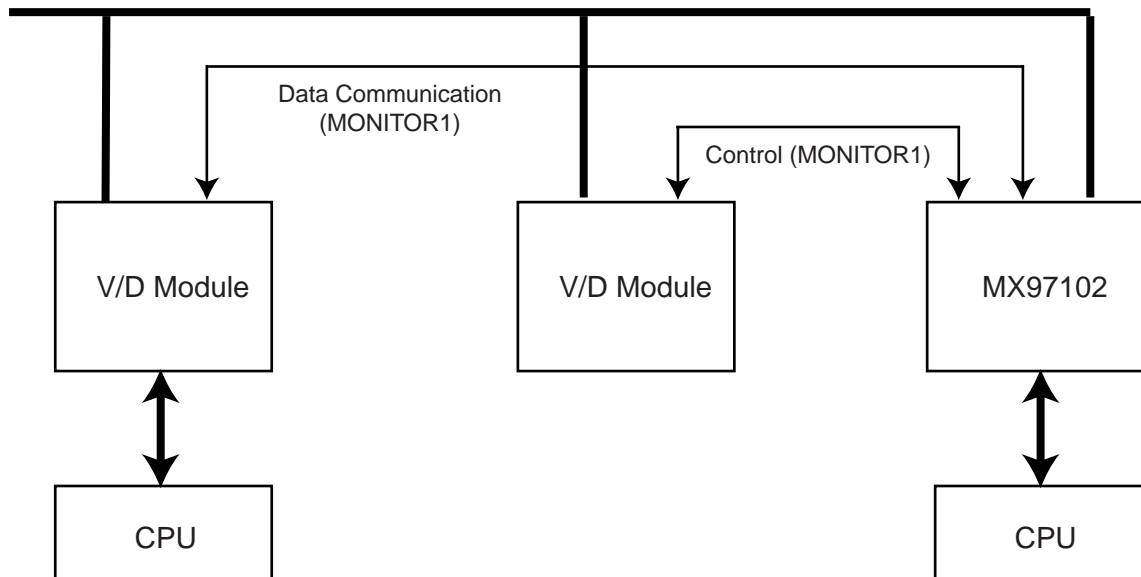


Figure 6-4 MONITOR channel applications in GCI interface

The MONITOR channel operates on an asynchronous basis. While data transfers on the bus take place synchronized to frame sync, the flow of data is controlled by a handshake procedure using the MONITOR Channel Receive (MR0 or MR1) and MONITOR Channel Transmit (MX0 or MX1) bits. For example: data is placed onto the MONITOR channel and the MX bit is activated. The data will be transmitted repeatedly once per 8kHz frame until the transfer is acknowledge via the MR bit.

The microprocessor may either enforce a "1" in MR, MX by setting the control bit MRC1, MRC0 or MXC1, MXC0 of the MOCR register to logic 0, or enable the control of these bits internally by the MX97102 according to the MONITOR channel protocol. Thus, before a data exchange can begin, the control bit MRC(1,0) or MXC(1,0) should be set to "1" by the microprocessor.

### MONITOR handshake procedure

#### - Idle

The MX and MR pair being held inactive for two or more frames constitutes the channel being idle in that direction.

#### - Start of transmission

Before starting a transmission, the CPU should verify that the transmitter is inactive, i.e. that a possible previous transmission has been terminated. This is indicated by a "0" in the MONITOR Channel Active (MAC) status bit. After having written the MONITOR Data Transmit (MOX) register, the microprocessor sets the MONITOR Transmit Control bit (MXC) to "1". This enables the MX bit to go active (0), indicating the pres-

ence of valid MONITOR data (contents of MOX) in the corresponding frame and remains active until an inactive-to-active transition (MDA) of MR is received, indicating the receiver has read the data off the bus. As a result, the receiving device stores the MONITOR byte in its MONITOR Receive register (MOR) and generates an MDR interrupt status.

There are two different cases, general case and maximum speed case, of the MONITOR handshake protocol. Bit MAX0(1) in the ADF3 register is set to "1" for selecting the maximum speed case of MONITOR 0(1).

\* As a general case (MAX=0):

The next byte is placed on the bus after the inactive to active transmission of MR as early as the next frame (there is no limit to the maximum number of frames). At the time that the second byte is transmitted, MX is returned inactive for one frame time (MX inactive for more than one frame time indicates an end of message). In response to MX going active, MR will be deactivated for one frame time (the MX inactive to MR inactive delay can be any number of frame times) after MOR is read. This procedure is repeated for each additional byte. (see Figure6-5)

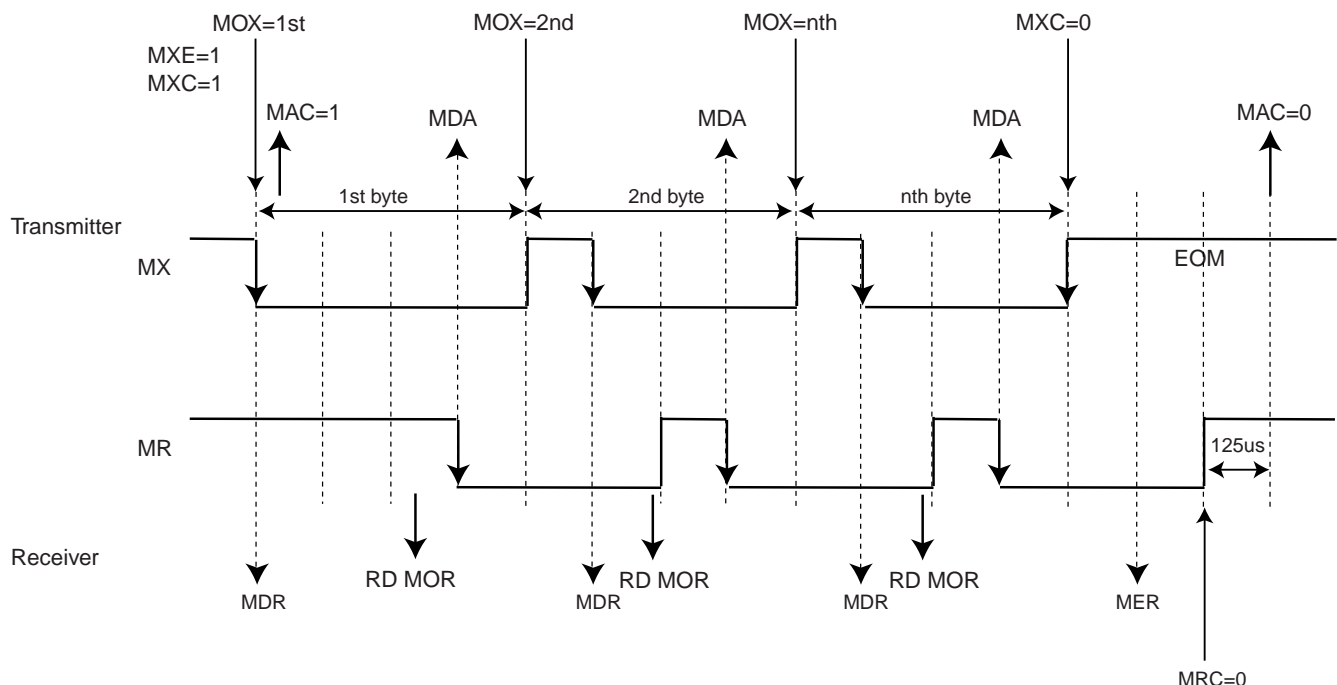
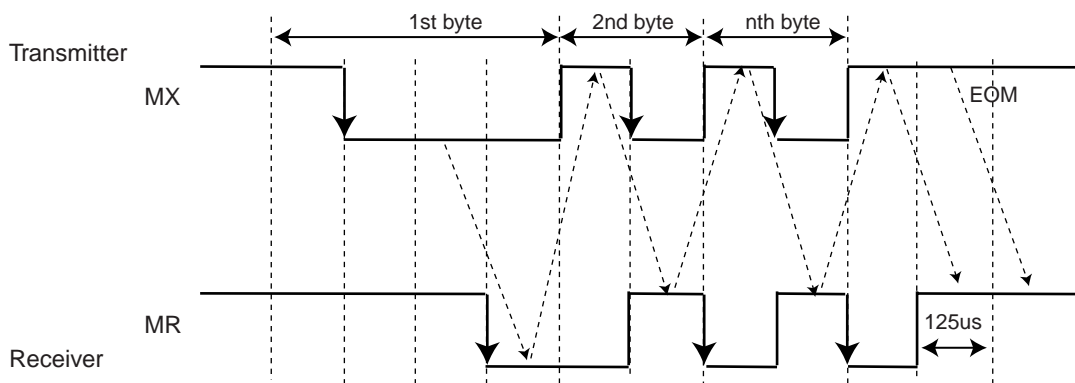


Figure 6-5 Timing chart of general case

As a maximum speed case (MAX=1):

The transmitter can be designed for a higher data throughput than is provided by the general case described above. The transmitter can deactivate MX and transmit new data one frame time after MR is deactivated. In this way, the transmitter is anticipating that

MR will be reactivated one frame time after it is deactivated, minimizing the delay between bytes (see Figure 6-6). Note that MR being held inactive for two or more frame times indicates an abort is being signaled by the receiver.



\* Transmitter anticipates the falling edge of the receiver's acknowledgment  
 \* Signals from/to CPU are the same with general case (Figure 6-8)

**Figure 6-6 Timing chart of maximum speed case**

**- First byte reception**

At the time the receiver sees the the first byte, indicated by the inactive-to-active transition of MX (MDR), MR is by definition inactive. In response to the activation of MX, microprocessor reads the MONITOR Receive (MOR) register. When it is ready to accept data (e.g. based on the value in MOR, which in a point-to-multipoint application might be the address of the destinating device), it sets the MR control bit (MRC) to "1" to enable the receiver to store succeeding MONITOR channel bytes and acknowledge them according to the MONITOR channel protocol. In addition, it enables other MONITOR channel interrupts by setting MONITOR Interrupt Enable (MRE) to "1".

**- Subsequent reception**

Data is received from the bus on each falling edge of MX, and a MDR is generated. Note that the data may actually be valid at the time that MX went inactive, one frame time prior to going active. MR is deactivated after the data is read and reactivated one frame time later. The transmitter will detect MR going inactive and anticipate its reactivation one frame time later. The transmission of the next data byte will begin at the same time that MR is going active.

This "MDA interrupt - write data - MDR interrupt - read data - MDA interrupt" handshake is repeated as long as the transmitter has data to send.

**-End of transmission (EOM)**

When the last byte has been acknowledged by the receiver, the microprocessor sets the MONITOR Transmit Control bit (MXC) to "0". This enforces an inactive "1" state in the MX bit. Two frames of MX inactive signifies the end of a message. Thus, a MONITOR Channel End of Reception (MER) interrupt status is generated by the receiver when the MX bit is received in the inactive state in two consecutive frames. As a result, the microprocessor sets the MRC to 0, which in turn enforces an inactive state in the MR bit. This marks the end of the transmission, making the MONITOR Channel Active (MAC) bit return to "0".

**- Abort**

During a transmission process, it is possible for the receiver to ask a transmission to be aborted by sending an inactive MR bit value in two consecutive frames. This is effected by the microprocessor writing the MRC bit to "0". An aborted transmission is indicated by a MONITOR Channel Data Abort (MAB) interrupt status at the transmitter.

## C/I-Channel Handling & TIC-Bus Access

The command/indication channel carries real-time status information between the MX97102 and another device connected to the GCI.

- One C/I channel (called C/I 0) conveys the commands and indications between the layer-1 and the layer-2 parts of the MX97102. It can be accessed by an external layer-2 device e.g. to control the layer-1 activation/deactivation procedures. C/I 0 channel access may be arbitrated via the TIC bus access protocol. In this case the arbitration is done in C/I channel 2.

The C/I 0 code is four bits long, could be read from CIR0 (layer-1 to layer-2) and write to CIX0 (layer-2 to layer-1).

In the receive direction, the code from layer-1 is continuously monitored, with an interrupt being generated any time a change occurs (CISQ). A new code must be found in two consecutive GCI frames to be considered valid and to trigger a C/I code change interrupt status (double last look criterion).

- A second C/I channel (called C/I 1) can be used to convey real time status information between the MX97102 and various non-layer-1 peripheral devices such as ARCOFI. The channel consists of six bits in each direction.

The C/I 1 channel is accessed via registers CIR1 and CIX1. A change in the received C/I 1 code is indicated by an interrupt status without double last look criterion.

The TIC-bus arbitration mechanism implemented in the last octet of GCI channel 2 of the GCI allows the access of external communication controller (up to 7) to the layer-1 functions provided in the MX97102 and to the D channel. To this effect the outputs of the controllers are wired-and connected to pin IDP1. The inputs of the ICCs are connected to pin IDP0. External pull-up resistors on IDP0/1 are required. The arbitration mechanism must be activated by setting MODE: DIM2-0=001.

An access request to the TIC bus may either be generated by software (CPU access to the C/I channel) or by the MX97102 itself (transmission of an HDLC frame). A software access request to the bus is effected by setting the BAC bit (CIX0 register) to "1".

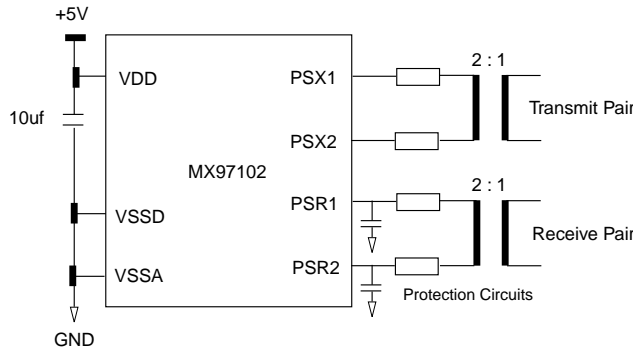
In the case of an access request, the MX97102 checks the Bus Accessed-bit (bit 5 of IDP1 last octet of CH2, see Figure6-1) for the status "bus free", which is indicated by a logical "1". If the bus is free, the MX97102 transmits its individual TIC-bus address programmed in the STCR register. The TIC bus is occupied by the device which sends its address error-free. If more than one device attempt to seize the bus simultaneously, the one with the lowest address value wins.

When the TIC bus is seized by the MX97102, the BAC-bit on IDP1 is "0" until the access request is withdrawn. After a successful bus access, the MX97102 is automatically set into lower priority class, that is, a new bus access cannot be performed until the status "bus free" is indicated in two successive frames.

If none of the devices connected to the GCI interface request access to the D and C/I channels, the TIC-bus address 7 will be present. The device with this address will therefore have access, by default, to the D and C/I channels. The availability of the S/T interface D channel is indicated in bit5 "Stop/Go" (S/G=1: stop, S/G=0: go) of the IDP0 last octet of C/I channel (Figure6-1).

## S/T interface

Line transceiver functions for the S/Y interface follow the electrical specifications of CCITT I.430. According to this standard, pseudo-ternary encoding with 100% pulse width is used on the S/T interface. For both receive and transmit direction, a 2:1 transformer is used to connect the MX97102 transceiver to the 4 wire S/T interface.



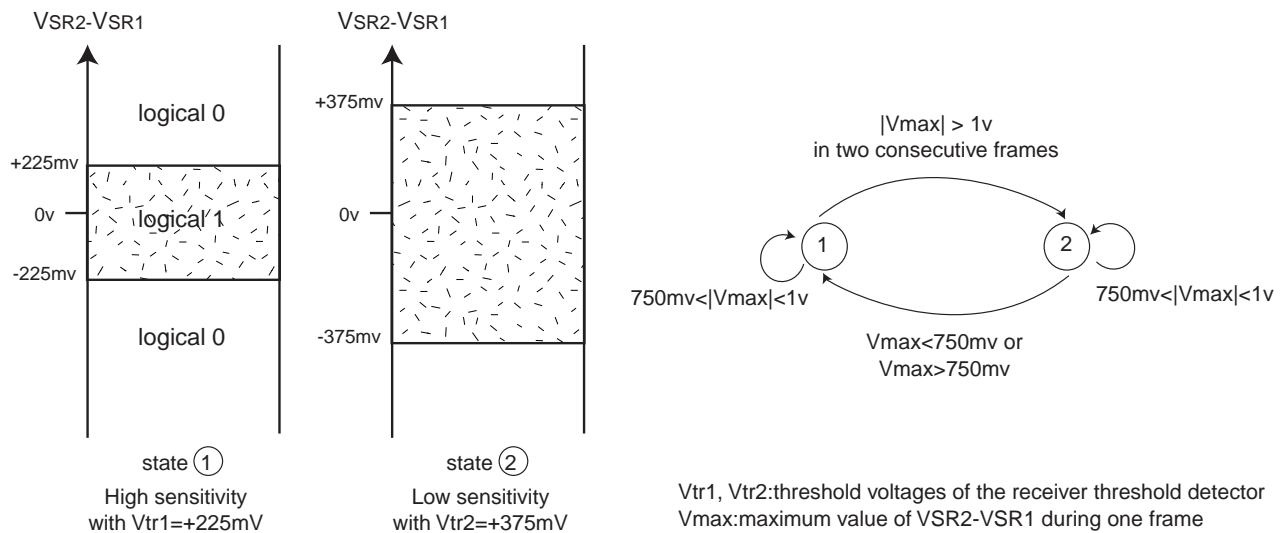
**FIGURE 6-7: MX97102 EXTERNAL S-INTERFACE CIRCUITRY**

### - Pre-Filter Compensation

To compensate for the extra delay introduced into the received signal by a filter, the sampling of the receive signal can be delayed by programming bits TEM and PFS in the ADF1 register as shown below.

TEM	PFS	
0	0	no delay
0	1	delay 650ns
1	1	advance 390ns
1	0	test mode

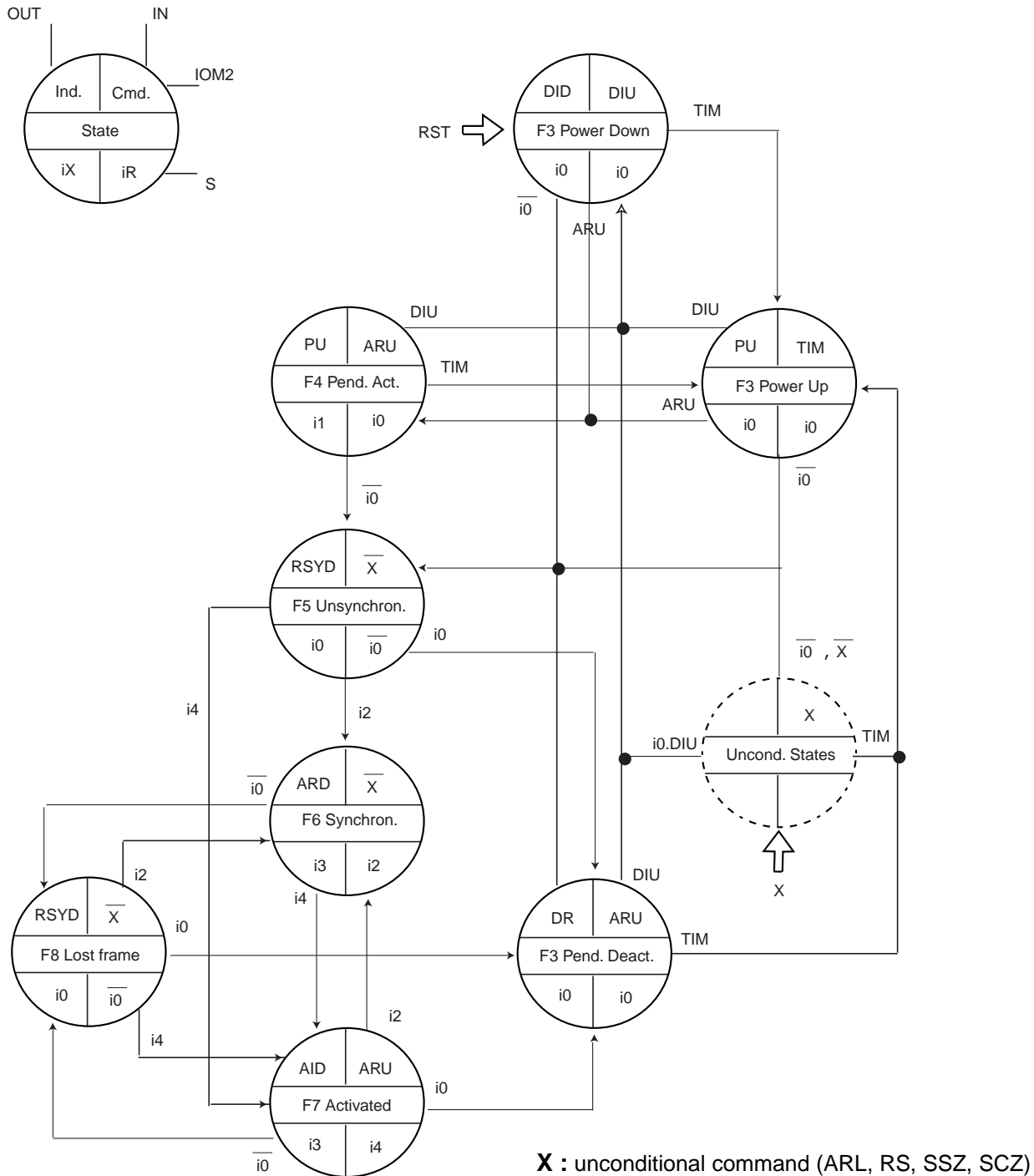
The receiver is designed as a threshold detector with adaptively switched threshold levels. Pin PSR1 delivers 2.5V as an output, which is the virtual ground of the input signal on pin PSR2. The detector controls the switching of the receiver between two sensitivity levels (see Figure6-8).

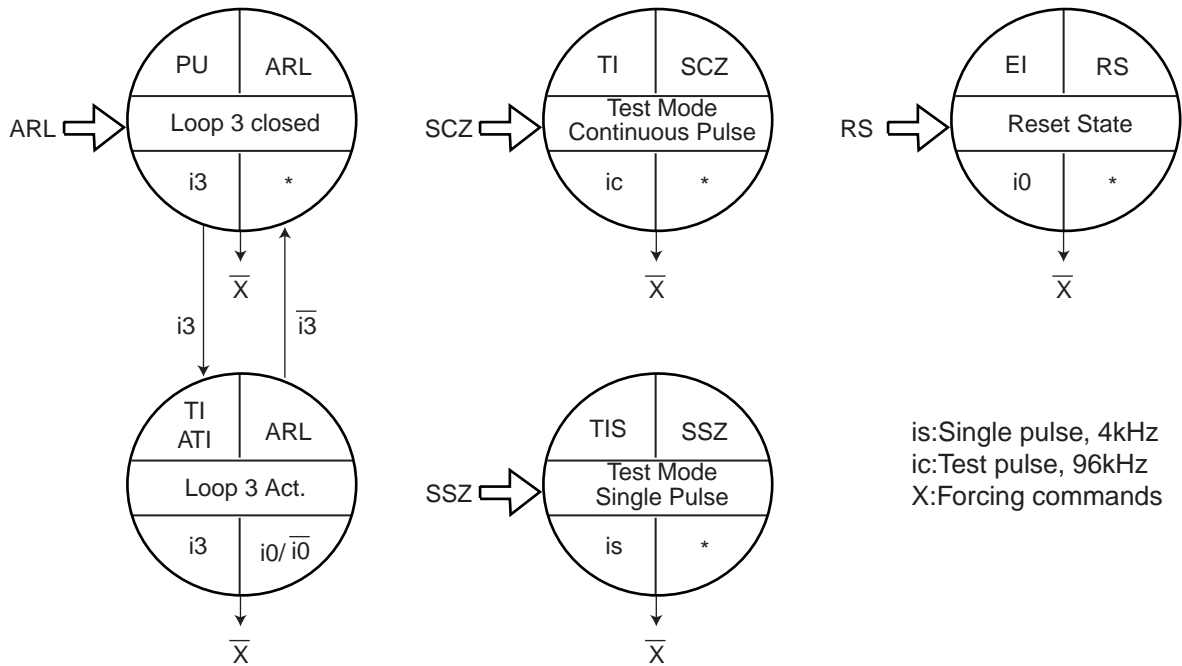


**Figure 6-8 State diagram of the adaptive receiver**

**Activation/Deactivation**

An incorporated finite state machine controls ISDN layer-1 activation/deactivation according to CCITT I.430. Figure 6-9 shows the state diagrams. Table 7-2 and Table 7-3 indicate the command and indication code descriptions.


**Figure 6-9(a) State diagram**


**Figure 6-9(b) State diagram : unconditional transitions**

Command (upstream)	Abbr.	Code	Reamrks
Timing	TIM	0000	Activation of all output clocks is requested
Reset	RS	0001	(X)
Send continuous zeros	SCZ	0100	Transmission of pseudo-ternary pulses at 96kHz frequency (X)
Send single zeros	SSZ	0010	Transmission of pseudo-ternary pulses at 2kHz (X)
Activate request set priority 8	AR8	1000	Activation command, set D-channel priority to 8
Activate request set priority 10	AR10	1001	Activation command, set D-channel priority to 10
Activate request loop	ARL	1010	Activation of test loop 3 (X)
Deactivate indication upstream	DIU	1111	GCI-interface clocks can be disabled

Table 7-2 C/I command code descriptions





Note: When in the activated state (AI8/AI10) the 2B+D channels are only transferred from the GCI to the S/T interface if an "Activate Request" command is written to the CIX0 register.

Indication	Abbr.	Code	Reamrks
Power up	PU	0111	GCI clocking is provided
Deactivate request	DR	0000	Deactivation request by S interface
Error indication	EI	0110	Either : (pin PRST = 1 and bit CFS = 0) or RS
Level detected	RSYD	0100	Signal received, receiver not synchronous
Activate request downstream	ARD	1000	Info 2 received
Test indication	TI	1010	Test loop 3 activated or continuous zeros transmitted
Awake test indication	ATI	1011	Level detected during test loop
Activate indication with priority class 8	AI8	1100	Info 4 received, D-channel priority is 8 or 9
Activate indication	AI10	1101	Info 4 received, D-channel priority is 10 or 11
Deactivate indication downstream	DID	1111	Clocks will be disabled in MX97102, quiescent state
Single zero transmitted	TIS	0101	Send single zeros at 2kHz frequency

Table 7-3 C/I command code descriptions

**Level Detection Power Down**

In power down state, only an analog level detector is active. All clocks, including the GCI interface, are stopped. The data lines are "high" whereas the clocks are "low".

An activation initiated from the exchange side (Info2 in S bus detected) will have the consequence that a clock signal is provided automatically.

From the terminal side an activation must be started by setting and resetting the SPU bit in the SPCR register.

### D-channel Access

The D-channel access procedure according to CCITT I.430 including priority management is fully implemented in the MX97102. By programmed the DIM2-0 (MODE register) to 001 or 011, stop/go bit is evaluated for D-channel access handling, that is, a collision is detected if the corresponding echo-bit value is different from the transmitted D-bit value. When this occurs, D-channel transmission is immediately stopped, and the echo channel is monitored to enable a subsequent D-channel access to be attempted.

The priority class (priority 8 or priority 10) is selected by transferring the appropriate activation command via the command/indication (C/I) channel of the GCI interface to the layer-1 controller.

#### 6.3.10 S- and Q- channel access

Access to the received/transmitted S- or Q- channel is provided via registers. As specified by CCITT I.430, the Q bit is transmitted from TE to NT in the position normally occupied by the auxiliary framing bit (FA) in one frame out of 5, whereas the S bit is transmitted from NT to TE in a spare bit (S). The functions provided by the MX97102 are:

- Synchronization to the received 20 frame multiframe by means of the received M bit pattern. Synchronism is achieved when the M bit has been correctly received during 20 consecutive frames starting from frame number 1 (Table7-4).

- When synchronism is achieved, the four received S bits in frames 1, 6, 11, 16 are stored as SQR1 to SQR4 in the SQRR register if the complete M bit multiframe pattern was correctly received in the corresponding multiframe. A change in any of the received four bits is indicated by an interrupt (CISQ in ISTA and SQC in CIR0).

- When an M bit is observed to have a value different from that expected, the synchronism is considered lost. The SQR bits are not updated until synchronism is regained. The synchronization state is constantly indicated by the SYN bit in the SQRR register.

- When synchronism with the received multiframe is achieved, the four bits SQX1 to SQX4 stored in the SQXR register are transmitted as the four Q bit (FA-bit position) in frames 1, 6, 11, 16 respectively (starting from frame number one). Otherwise the bit transmitted is a mirror of the received FA-bit. At loss of synchronism (mismatch in M bit) the mirroring is resumed starting with the next FA-bit.

- The S/T multiframe synchronization can be disabled in the STAR register (MULT bit).



Frame Number	NT-to-TE FA-Bit position	NT-to-TE M Bit	NT-to-TE S Bit	TE-to-NT FA-Bit position
1	ONE	ONE	S1	Q1
2	ZERO	ZERO	ZERO	ZERO
3	ZERO	ZERO	ZERO	ZERO
4	ZERO	ZERO	ZERO	ZERO
5	ZERO	ZERO	ZERO	ZERO
6	ONE	ZERO	S2	Q1
7	ZERO	ZERO	ZERO	ZERO
8	ZERO	ZERO	ZERO	ZERO
9	ZERO	ZERO	ZERO	ZERO
10	ZERO	ZERO	ZERO	ZERO
11	ONE	ZERO	S3	Q3
12	ZERO	ZERO	ZERO	ZERO
13	ZERO	ZERO	ZERO	ZERO
14	ZERO	ZERO	ZERO	ZERO
15	ZERO	ZERO	ZERO	ZERO
16	ONE	ZERO	S4	Q4
17	ZERO	ZERO	ZERO	ZERO
18	ZERO	ZERO	ZERO	ZERO
19	ZERO	ZERO	ZERO	ZERO
20	ZERO	ZERO	ZERO	ZERO
1	ONE	ONE	S1	Q1
2	ZERO	ZERO	ZERO	ZERO
etc.				

Table 7-4 S- and Q-channel Structure

**Terminal Specific Functions**

The MX97102 provides the following optional functions by setting bit TSF (STCR register) to “1”. When terminal specific functions are activated (TSF=1), bit RSS (CIX0 register) is programmed for selecting Watchdog Function (RSS=1) or External Awake Function (RSS=0). Deactivating the terminal specific functions is only possible with a hardware reset.

**Watchdog Function (TSF=1, RSS=1):**

During every time period of 128ms the processor has to program the WTC1 and WTC2 bits in the sequence, (WTC1, WTC2) = (1, 0) then (0, 1), to reset and restart the watchdog timer. Otherwise, the timer expires and a WOV interrupt (EXIR) together with a 125ms reset pulse is generated.

**External Awake Function**

A 16ms reset signal is generated by either a falling edge on the EAW line (subscriber awake) or a C/I code change (exchange awake). A corresponding interrupt status (SAW or CISQ) is also generated. Moreover, It forces the IDP1 line of the GCI interface to zero. The consequence of this is that the GCI interface and the MX97102 leaves the power-down state.

## Test Functions

The MX97102 provides several test and diagnostic functions which can be grouped as follows:

- digital loop via TLP (Test Loop, SPCR register) command bit: IDP1 is internally connected with IDP0, output from layer 1 (S/T) on IDP0 is ignored; this is used for testing MX97102 functionality excluding layer 1;

- test of layer-2 functions while disabling all layer-1 functions and pins associated with them (including clocking), via bits TEM and PFS (Test Mode in ADF1 register); the MX97102 is then fully compatible to the ICC (Siemens PEB2070) seen at the IOM2 interface.

- loop at the analog end of the S interface;

Test loop 3 is activated with the C/I-channel command Activate Request Loop (ARL). An S interface is not required since INFO3 is looped back to the receiver. When the receiver has synchronized itself to this signal, the message "Test Indication" ( or "Awake Test Indication") is delivered in the C/I channel.

In the test loop mode the S-interface awake detector is enabled i.e. if a level is detected (e.g. Info2 /Info4) this will be reported by the Awake Test Indication (ATI). The loop function is not effected by this condition and the internally generated 192 kHz line clock does not depend on the signal received at the S interface.

## Layer-2 Functions for the ISDN-Basic Access

LAPD, layer 2 of the D-channel protocol (CCITT I.441) includes functions for:

- Provision of one or more data link connections on a D channel (multiple LAP). Discrimination between the data link connections is performed by means of a data link connection identifier (DLCI = SAPI + TEI).

- HDLC framing

- Application of a balanced class of procedure in point-multipoint configuration.

For the support of LAPD the MX97102 contains an HDLC transceiver which is responsible for flag generation/recognition, bit stuffing mechanism, CRC check and address recognition. A powerful FIFO structure with two 64-byte pools for transmit and receive directions and

an intelligent FIFO controller permit flexible transfer of protocol data units to and from the CPU system.

The HDLC controller can be programmed to operate in various modes, which are different in the treatment of the HDLC frame in receive direction. Thus, the receive data flow and the address recognition features can be programmed in a flexible way.

In the auto mode the MX97102 handles elements of procedure of the LAPD (S and I frames) according to CCITT I.441 fully autonomously. For the address recognition the MX97102 contains four programmable registers for individual SAPI and TEI values SAP1-2 and TEI1-2, plus two fixed values for "group" SAPI and TEI, SAPG and TEIG.

There are 5 different operating modes which can be set via the MODE register.

- Auto-mode (MDS2, MDS1 = 00)

Characteristics:

- \* Full address recognition (1 or 2 bytes)
- \* Normal (mod 8) or extended (mod 128) control field format
- \* Automatic processing of numbered frames of an HDLC procedure

If a 2-byte address field is selected, the high address byte is compared with the fixed hex value FE or FC (group address) as well as with two individually programmable values in SAP1 and SAP2 registers. According to the ISDN LAPD protocol, bit 1 of the high byte address will be interpreted as command/response bit (C/R) dependent on the setting of the CRI bit in SAP1, and will be excluded from the address comparison. Similarly, the low address byte is compared with the fixed hex value FF (group TEI) and two compare values programmed in special registers (TEI1, TEI2). A valid address will be recognized in case the high and low byte of the address field match one of the compare values. The MX97102 can be called (addressed) with the following address combination:

- \* SAP1/TEI1
- \* SAP1/FF (hex value)
- \* SAP2/ TEI2
- \* SAP2/FF (hex value)
- \* FE or FC (hex value)/TEI1
- \* FE or FC (hex value)/TEI2
- \* FE or FC (hex value)/FF (hex value)

Only the logical connection identified through the address combination SAP1, TEI1 will be processed in the auto mode, all others are handled as in the non-auto mode. The logical connection handled in the auto-mode must have a window size 1 between transmitted and acknowledged frames. HDLC frames with address fields that do not match with any of the address combinations, are ignored by the MX97102. In case of a 1-byte address, TEI1 and TEI2 will be used as compare registers. According to the X.25 LAPB protocol, the value in TEI1 will be interpreted as command and the value in TEI2 as response. The control field is stored in the RHCR register and the I field in the RFIFO. Additional information is available in the RSTA.

- Non-auto mode (MDS2, MDS1 = 01)

Characteristic:

- \* Full address recognition (1 or 2 bytes)
- \* Arbitrary window size

All frames with valid addresses (address recognition identical to auto mode) are accepted and the bytes following the address are transferred to the CPU via RHCR and RFIFO. Additional information is available in the RSTA.

- Transparent mode 1 (MDS2, MDS1, MDS0 = 101)

Characteristic: TEI recognition

A comparison is performed only on the second byte after the opening flag, with TEI1, TEI2 and group TEI (FF hex value), and the rest of the frame in the RFIFO. Additional information is available in the RSTA.

- Transparent mode 2 (MDS2, MDS1, MDS0 = 110)

Characteristic: No address recognition

Every received frame is stored in the RFIFO (first byte after opening flag to CRC field). Additional information is available in the RSTA.

- Transparent mode 3 (MDS2, MDS1, MDS0 = 111)

Characteristic: SAPI recognition

A comparison is performed on the first byte after the opening flag with SAP1, SAP2 and group SAPI (FE/FC hex value). In the case of match, all the following bytes are stored in the RFIFO. Additional information is available in the RSTA.

### Reception of Frames

A 2\*32 byte FIFO buffer (receive pools) is provided in the receive direction. The control of the data transfer between the CPU and the MX97102 is handled via interrupts.

- RPF (Receive Pool Full) interrupt, indicating that a 32-byte block of data can be read from the RFIFO and the received message is not yet complete.
- RME (Receive Message End) interrupt, indicating that the reception of one message is completed, i.e. either one message \* 32 bytes or the last part of a message > 32bytes is stored in the RFIFO.

The organization of the RFIFO is such that up to two short (\* 32 bytes), successive messages, with all additional information can be stored (see Figure6-13).

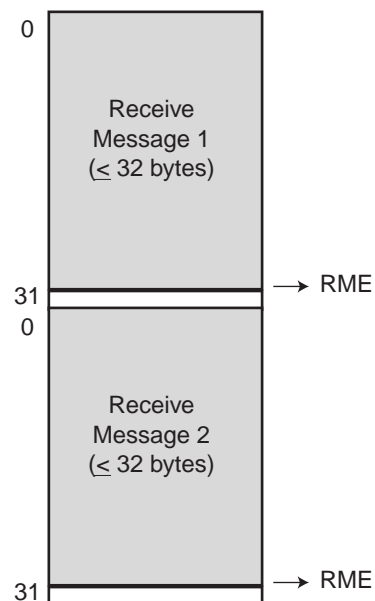
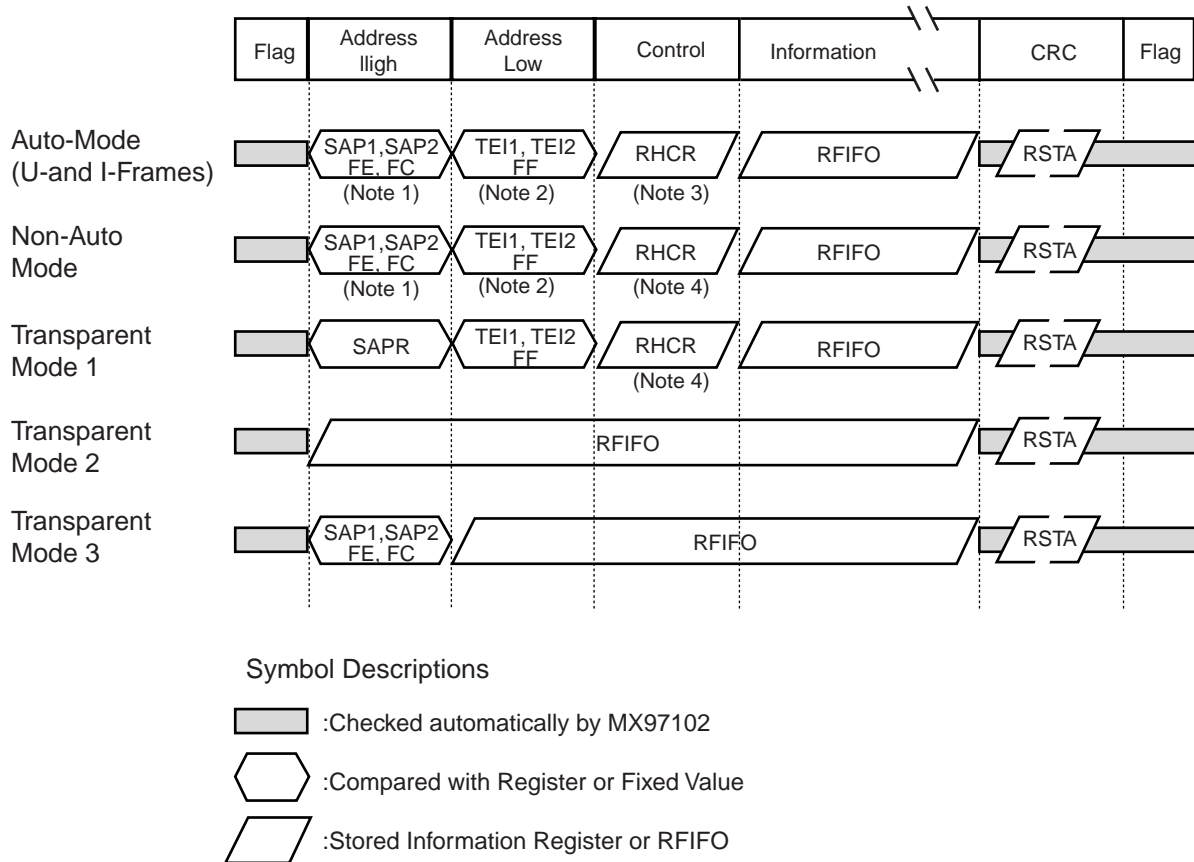


Figure 6-10 Contents of RFIFO (short message)

Depending on the message transfer mode the address and control fields of received frames are processed and stored in the Receive FIFO or in special registers as depicted in Figure 6-11.



**Figure 6-11 Receive Data Flow**

Note 1: Only if a 2-byte address field is defined (MDS0=1 in MODE register).

Note 2: Comparison with Group TEI is only made if a 2-byte address field is defined (MDS0=1).

Note 3: In the case of an extended, modulo 128 control field format (MCS=1 in SAP2 register) the control field is stored in the RHCR in compressed form (I frames).

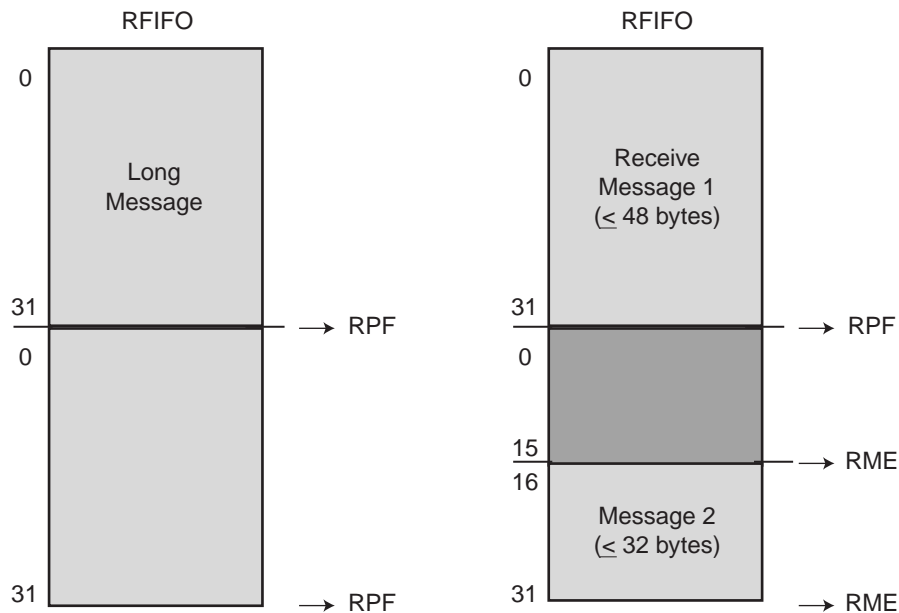
Note 4: In the case of extended control field, only the first byte is stored in the RHCR, the second in the RFIFO.

When 32 bytes of a message longer than that are stored in the RFIFO, the CPU is prompted to read out the data by an RPF interrupt. The CPU must handle this interrupt before more than 32 additional bytes are received, which would cause a "data overflow". This corresponds to a maximum CPU reaction time of 16ms (data rate 16 kbit/s).

After a remaining block of less than or equal to 16 bytes has been stored, it is possible to store the first 16 bytes of a new message (see Figure6-12). The internal memory is now full. The arrival of additional bytes will result in "data overflow" (RSTA:RDO) and a third new

message in "frame overflow" (EXIR:RFO). The generated interrupts are inserted together with all additional information into a queue to be individually passed to the CPU.

After an RPF or RME interrupt has been processed, i.e. the received data has been read from the RFIFO, this must be explicitly acknowledged by the CPU issuing an RMC (Receive Message Complete) command. The MX97102 can then release the associated FIFO pool for new data. If there is an additional interrupt in the queue it will be generated after the RMC acknowledgement.

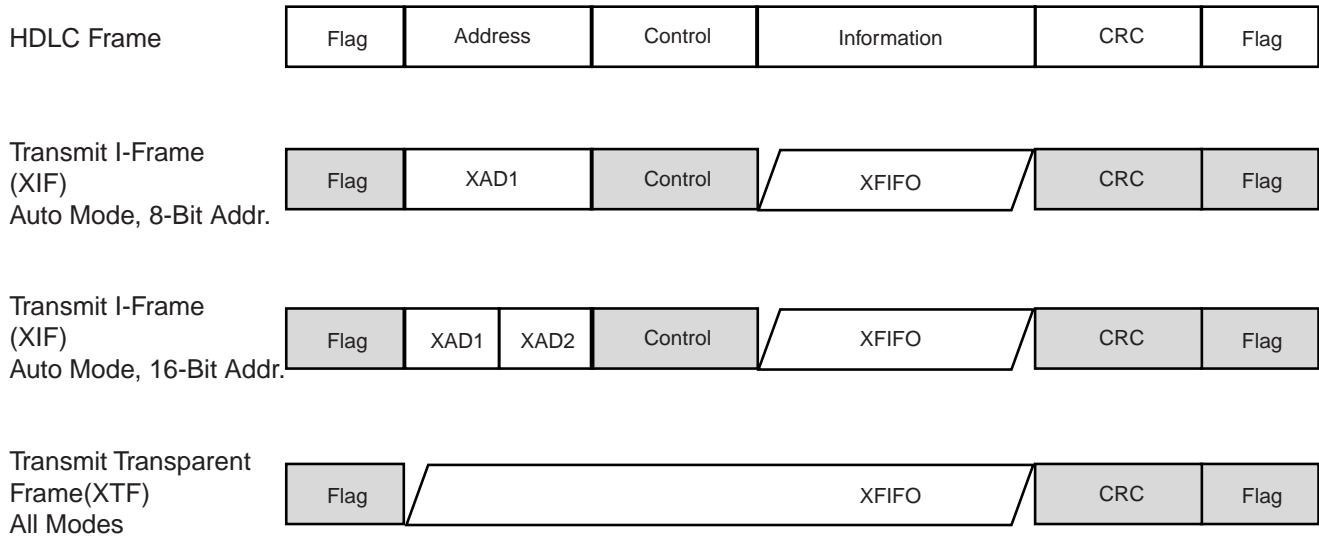





**Figure 6-12 Contents of the RFIFO (long messages)**

### Transmission of Frames

A 2\*32 byte FIFO buffer (transmit pools) is provided in the transmit direction. If the transmit pool is ready (which is true after an XPR interrupt or if the XFW bit in STAR is set), the CPU can write a data block of up to 32 bytes to the transmit FIFO. After this, data transmission can be initiated by command.

Two different frames types can be transmitted : Transparent frame (command: XTF) or I frames (command: XIF) as shown in Figure6-16. For transparent frames, the whole frame including address and control field must be written to the XFIFO.


**Symbol Descriptions**

-  :Generated automatically by MX97102
-  :Written initially by CPU (Info Register)
-  :Loaded (repeatedly) by CPU upon MX97102 request (XPR interrupt)

Note: Length of Control Field is 8 or 16 Bit

**Figure 6-13 Transmit Data Flow**



If a 2-byte address field has been selected, the MX97102 takes the contents of the XAD1 register to build the high byte of the address field, and the XAD2 register to build to low byte of the address field. Additionally the C/R bit (bit 1 of the high byte address, as defined by LAPD protocol ) is set to "1" or "0" dependent on whether the frame is a command or a response. In the case of a 1 byte address, the MX97102 takes either the XAD1 or XAD2 register to differentiate between command or response frame (as defined by X.25 LAPB).

The control field is also generated by the MX97102 including the receive and send sequence number and the poll/final (P/F) bit. For this purpose, the MX97102 internally manages send and receive sequence number counters.

In the auto-mode, S frames are sent autonomously by the MX97102. The transmission of U frames, however, must be done by the CPU. U frames must be sent as transparent frames (CMDR: XTF), i.e. address and control field must be defined by the CPU. Once the data transmission has been initiated by command (CMDR: XTF or XIF), the data transfer between CPU and the MX97102 is controlled by interrupts.

The MX97102 repeatedly requests another data packet or block by means of an ISTA:XPR interrupt, every time no more than 32 bytes are stored in the XFIFO. The processor can then write further data to the XFIFO and enable the continuation of frame transmission by issuing an XIT/XTF command. If the data block which has been written last to the XFIFO completes the current frame, this must be indicated additionally by setting the XME (Transmit Message End) command bit. The MX97102 then terminates the frame properly by appending the CRC and closing flag.

If the CPU fails to respond to an XPR interrupt within the given reaction time, a data underrun condition occurs (XFIFO holds no further valid data). In this case, the MX97102 automatically aborts the current frame by sending seven consecutive "ones" (ABORT sequence). And the CPU is informed about this via an XDU (Transmit Data Underrun) interrupt. It is also possible to abort a message by software by issuing a CMDR:XRES (Transmitter Reset) command, which

causes an XPR interrupt.

After an end of message indication from the CPU (CMDR: XME command), the termination of the transmission operation is indicated differently, depending on the selected message transfer mode and the transmitted frame type.

If the MX97102 is operating in the auto mode, the window size is limited to "1"; therefore an acknowledgement may be provided either by a received S or I frame with corresponding receive sequence number. If no acknowledgement is received within a certain time (programmable), the MX97102 requests an acknowledgement by sending an S frame with the poll bit set (P=1) (RR or RNR). If no response is received again, this process is repeated in total N2 times (retry count, programmable via TIMR register).

The termination of the transmission operation may be indicated either with:

- XPR interrupt, if a positive acknowledgement has been received,
- XMR interrupt, if a negative acknowledgement had been received, i.e. the transmitted message must be repeated (XMR = Transmit Message Repeat),
- TIN interrupt, if no acknowledgement has been received at all after N2 times the expiration of the time period t1 (TIN = Timer INterrupt, XPR interrupt is issued additionally).

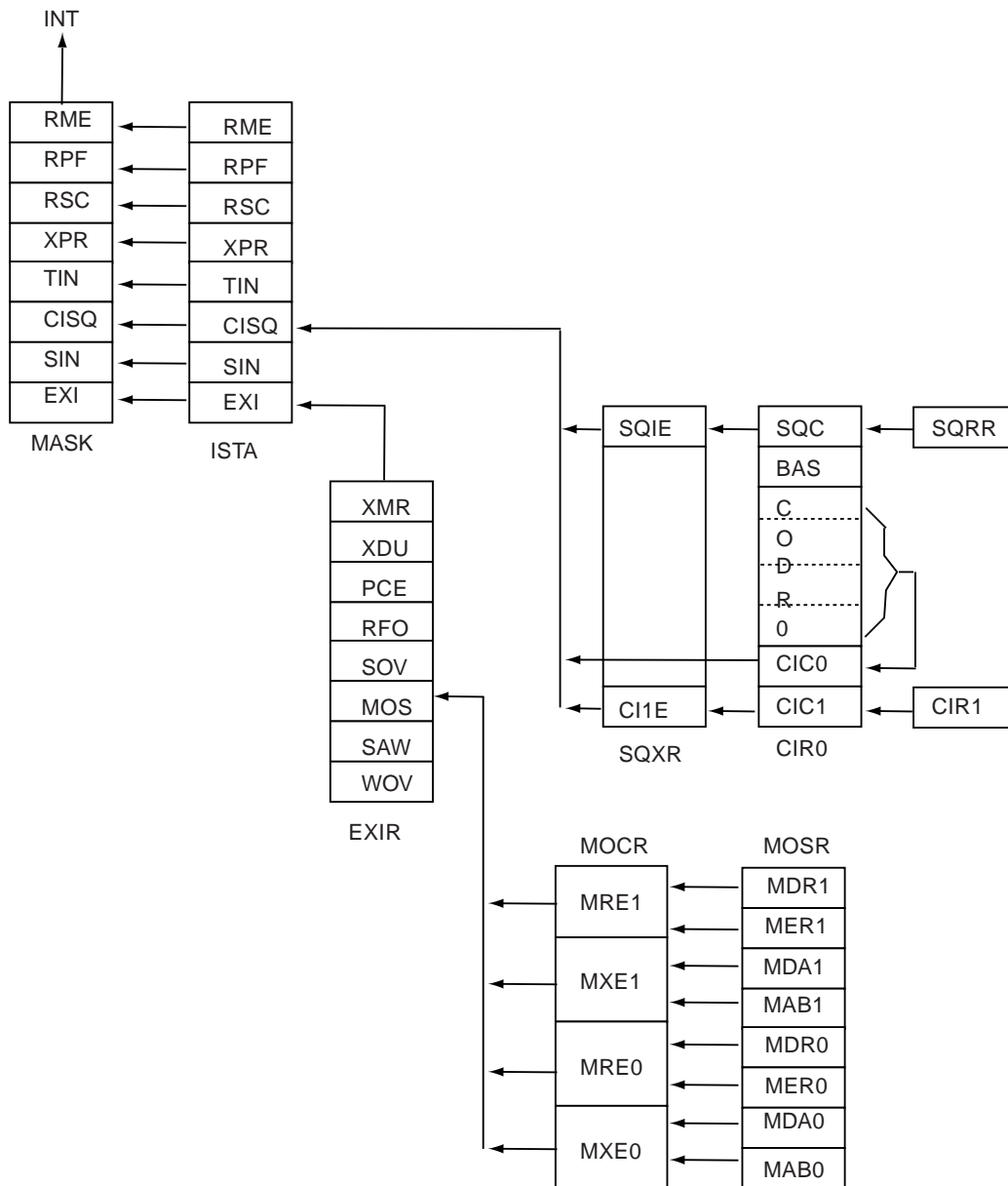
Note: Prerequisite for sending I frames in the auto-mode (XIF) is that the internal operational mode of the timer has been selected in the MODE register (TMD bit = 1).

The transparent transmission of frames (XTF command) is possible in all message transfer mode. The successful termination of a transparent transmission is indicated by an XPR interrupt.

In all cases, collisions which occur on the S-Bus (D channel) before the first XFIFO pool has been completely transmitted and released are treated without CPU interaction. The MX97102 will retransmit the frame automatically. If a collision is detected after the first pool has been released, the MX97102 aborts the frame and requests the processor to repeat the frame with an XMR interrupt.

**Interrupt Structure and Logic**

Since the MX97102 provides only one interrupt request output (INT), the cause of an interrupt is determined by the microprocessor by reading the Interrupt Status Register (ISTA). In this register, seven interrupt sources can be directly read. The LSB of the ISTA points to eight non-critical interrupt sources which are indicated in the Extend Interrupt Register (EXIR). Figure6-16 shows the MX97102 interrupt structure.


**Figure6-14 MX97102 Interrupt Structure**



A read of the ISTA register clears all bits except EXI and CISQ. CISQ is cleared by reading CIR0.

A read of EXIR clears the EXI bit in ISTA as well as the EXIR register. When all bits in ISTA are cleared, the interrupt line (PINTN) is deactivated.

Each interrupt source in ISTA register can be selectively masked by setting to "1" the corresponding bit in MASK. Masked interrupt status bits are not indicated when ISTA is read. Instead, they remain internally stored and pending, until the mask bit is reset to zero. Reading the ISTA while a mask bit is active has no effect on the pending interrupt.

In the event of an extended interrupt and of a C/I or S/Q channel change, EXI and CISQ are set even when the corresponding mask bits in MASK are active, but no interrupt (INT) is generated. Except for CISQ and MOS all interrupt sources are directly determined by a read of ISTA and (possibly) EXIR.

A CISQ interrupt may originate from a change in the received S/Q code (SQC), from a change in the received C/I channel 0 code (CIC0) or from a change in the received C/I channel 1 code (CIC1). These three corresponding status bits SQC, CIC0 and CIC1 are read then cleared in the CIR0 register. SQC and CIC1 can be individually disabled by clearing the enable bit SQIE (SQXR register) or, respectively, CI1E (SQXR register).

An interrupt status is indicated every time a valid new code is loaded in SQRR, CIR0 or CIR1. But in case of a code change, the new code is not loaded until the

previous contents have been read. When this is done and a second code change has already occurred, a new interrupt is immediately generated and the new code replaces the previous one in the register. The code registers are buffered with a FIFO size of two. Thus, if several consecutive codes are detected, only the first and the last code is obtained at the first and second register read, respectively.

The MONITOR Data Receive (MDR) and the MONITOR End of Reception (MER) interrupt status bits have two enable bits, MONITOR Receive interrupt Enable (MRE) and MR bit Control (MRC). The MONITOR channel Data Acknowledged (MDA) and MONITOR channel Data Abort (MAB) interrupt status bits have a common enable bit MONITOR Interrupt Enable (MXE).

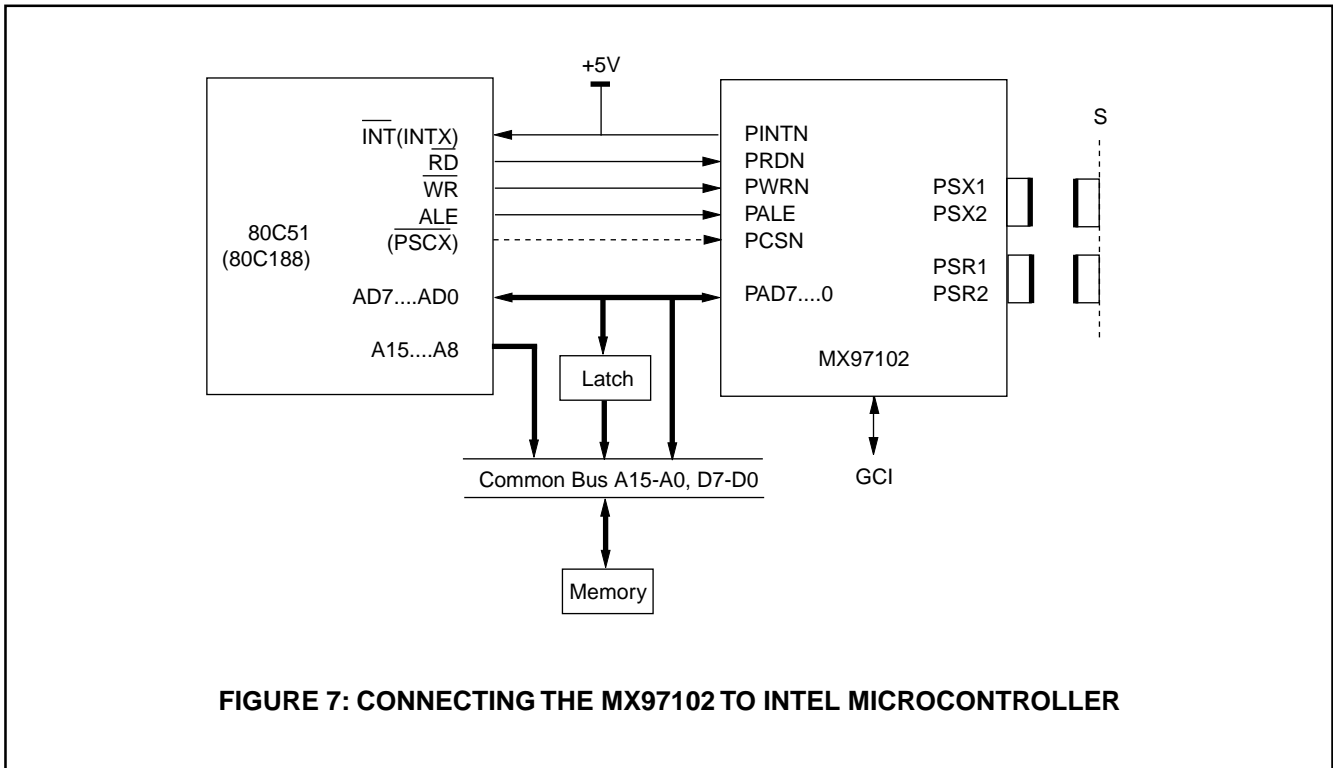
MRE prevents the occurrence of the MDR status, including when the first byte of a packet is received. When MRE is active (1) but MRC is inactive, the MDR-interrupt status is generated only for the first byte of a receive packet. When both MRE and MRC are active, MDR is generated and all received monitor bytes - marked by a 1-to-0 transition in MX bit - are stored.

The INT output is level active. It stays active until all interrupt sources have been serviced. If a new status bit is set while an interrupt serviced, the INT line stays active. This may cause problem if the MX97102 is connected to edge-triggered interrupt controllers. To avoid these problems, it is recommended to mask all interrupts at the end of the interrupt service program and to enable the interrupts again. This is done by writing FF hex value to the MASK register and to write back the old value of the MASK register.

## MICROPROCESSOR INTERFACE CONNECTION

Single-chip microcontroller, such as 8048, 8031 or 8051, can meet the need of MX97102. MX97102 is built in various microprocessor interface, it fits perfectly into almost any 8-bit microprocessor system environment. The microprocessor interface can be selected to be ei-

ther of the Motorola type (with control signals CS, R/W, DS) of the Siemens/Intel non-multiplexed bus type (with control signals CS, WR, RD) or of the Siemens/Intel multiplexed address/data bus type (with WR, RD, ALE).

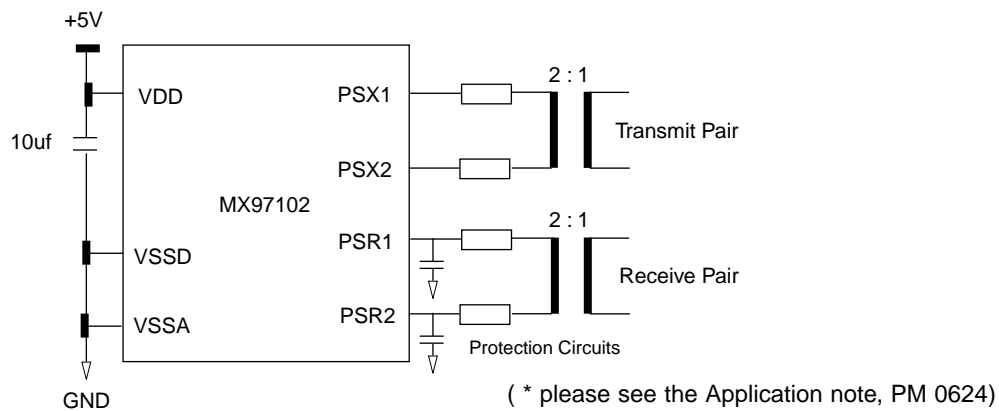


**FIGURE 7: CONNECTING THE MX97102 TO INTEL MICROCONTROLLER**

## S/T INTERFACE

Line transceiver functions for the S/T interface follows the electrical specifications of CCITT1.430. According to this standard, pseudo-ternary encoding with 100% pulse width is used on the S/T interface. For both re-

ceive and transmit direction, a 2:1 transformer is used to connect the MX97102 transceiver to the 4 wire S/T interface.



**FIGURE 8: MX97102 EXTERNAL S-INTERFACE CIRCUITRY**

The receiver is changed as a threshold detector with adaptively switched threshold levels. Pin PSR1 delivers 2.5V as an output, which is the virtual ground of the input signal on pin PSR2.

## E-channel Monitoring

This feature is provided by two ways, one way is to allow cpu to access two serial E-bits in a register, the other way is to get the E-bit signal from one pin of this chip. (please see Application Note PM0624 for details.)

## SDSX Programming

Strobes 1 and 2 are provided, please see the Application Note for details.



**INTERNAL REGISTER**

**TABLE 8 : HDLC OPERATION AND STATUS REGISTERS**

Addr. (hex)	Name	R/W	Bit7	Bit6	Bit5	Bit4	Bit3	Bit2	Bit1	Bit0	Description
00-1F	FIFO	R/W									Tx/Rx FIFO address
20	ISTA	R	RME	RPF	RSC	XPR	TIN	CISQ	SIN	EXI	Interrupt Status Register
20	MASK	W	RME	RPF	RSC	XPR	TIN	CISQ	SIN	EXI	Mask Register
21	STAR	R	XDOV	XFWD	XRNR	RRNR	MBR	MAC1	X	MAC0	Status Register
21	CMDR	W	RMC	RRES	RNR	STI	XTF	XIF	XME	XRES	Command Register
22	MODE	R/W	MDS2	MDS1	MDS0	TMD	RAC	DIM2	DIM1	DIM0	Mode Register
23	TIMR	R/W	CNT	CNT	CNT	V	A	L	U	E	Timer Register
24	EXIR	R	XMR	XDU	PCE	RFO	SOV	MOS	SAW	WOV	Extended Interrupt Register
24	XAD1	W									Transmit Address 1
25	RBCL	R	RBC7	RBC6	RBC5	RBC4	RBC3	RBC2	RBC1	RBC0	Receive Frame Byte Count Low
25	XAD2	W									Transmit Address 2
26	SAPR	R									Received SAPI
26	SAP1	W	SAPI1	SAPI1	SAPI1	SAPI1	SAPI1	SAPI1	CRI	0	Individual SAPI 1
27	RSTA	R	RDA	RDO	CRC	RAB	SA1	SA0	C/R	TA	Receive Status Register
27	SAP2	W	SAPI2	SAPI2	SAPI2	SAPI2	SAPI2	SAPI2	MCS	0	Individual SAPI 2
28	TEI1	W	TEI1	TEI1	TEI1	TEI1	TEI1	TEI1	TEI1	EA	Individual TEI 1
29	RHCR	R									Receive HDLC Control
29	TEI2	W	TEI2	TEI2	TEI2	TEI2	TEI2	TEI2	TEI2	EA	Individual TEI 2
2A	RBCH	R	XAC	VN1	VN0	OV	RBC11	RBC10	RBC9	RBC8	Receive Fram Byte Count High
2B	STAR2	R	0	0	0	0	WFA	MULT	TREC	SDET	Status Register 2
2B	STAR2	W	0	0	0	0	0	MULT	0	0	Status Register 2



**TABLE 9 : SPECIAL PURPOSE REGISTERS**

Addr. (hex)	Name	R/W	Bit7	Bit6	Bit5	Bit4	Bit3	Bit2	Bit1	Bit0	Description
30	SPCR	R/W	SPU	0	0	TLP	C1C1	C1C0	C2C1	C2C0	Serial Port Control Reg.
31	CIR0	R	SQC	BAS	CODR0	CODR0	CODR0	CODR0	CIC0	CIC1	Command/Indication Receive 0
31	CIX0	W	RSS	BAC	CODX0	CODX0	CODX0	CODX0	1	1	Command/Indication Transmit 0
32	MOR0	R									MONITOR Receive 0
32	MOX0	W									MONITOR Transmit 0
33	CIR1	R	CODR1	CODR1	CODR1	CODR1	CODR1	CODR1	MR1	MX1	Command/Indication Receive 1
33	CIX1	W	CODX1	CODX1	CODX1	CODX1	CODX1	CODX1	1	1	Command/Indication Transmit 1
34	MOR1	R									MONITOR Receive 1
34	MOX1	W									MONITOR Transmit 1
35	C1R	R/W									Channel Register 1
36	C2R	R/W									Channel Register 2
37	B1CR	R									B1-Channel Register
37	STCR	W	TSF	TBA2	TBA1	TBA0	ST1	ST0	SC1	SC0	Sync Transfer Control Register
38	B2CR	R									B2-Channel Register
38	ADF1	W	WTC1	WTC2	TEM	PFS	IOF	0	0	ITF	Additional Feature Reg.1
39	ADF2	R/W	IMS	0	0	0	ODS	D1C2	D1C1	D1C0	Additional Feature Reg.2
3A	MOSR	R	MDR1	MER1	MDA1	MAB1	MDR0	MER0	MDA0	MAB0	MONITOR Status Reg.
3A	MOCR	W	MRE1	MRC1	MXE1	MXC1	MRE0	MRC0	MXE0	MXC0	MONITOR Control Reg.
3B	SQRR	R	IDC	CFS	CI1E	SYN	SQR1	SQR2	SQR3	SQR4	S-,Q-Channel Receive Register
3B	SQXR	W	IDC	CFS	CI1E	SQIE	SQX1	SQX2	SQX3	SQX4	S-,Q-Channel Transmit Register
3C	ADF3	R/W	0	0	0	1	STM1	STM0	MAX1	MAX0	Additional Feature Reg.3
3D	EMR	R	0	0	0	0	0	0	EMR1	EMR0	E-channel bits reg.
3D	EDR	W	0	0	0	0	D_SIZER0	D_SFLAGS	D_UNARBEMON		D/E channel Control reg.
3E	ADF4	R/W	IMS	0	0	0	BFWD	D2C2	D2C1	D2C0	B-exchang, SDS2 reg.

**ORDERING INFORMATION**

PART NO.	PACKAGE
MX97102QC	44 PIN PLCC
MX97102UC	64 PIN LQFP



**REVISION HISTORY**

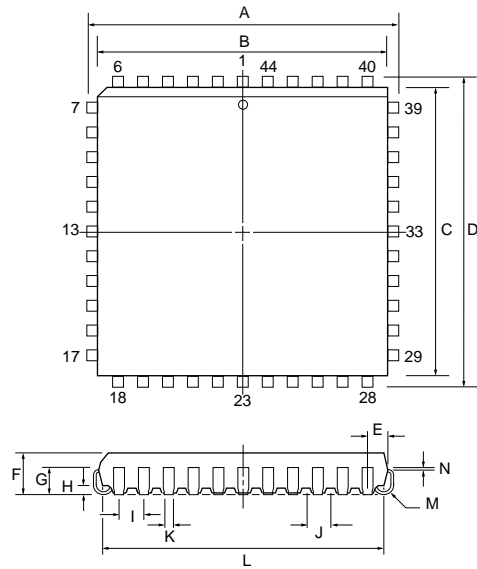
Rev. No.	Description	Page	Date
1.1	Preliminary release		JULY/28/1997
1.2	Change editing Add ordering information and revision history Change words in drawings Add "not used" pins in pin descriptions		NOV/1997
1.3	Page6, Table 3 changed		NOV/1997
1.4	Wording errors		APR/14/1998
1.5	Change feature description		MAY/21/1998
1.6	Storage Temperature Range " -65°C to 125°C" replaced by "-55°C to 150°C"	P4	JUN./15/1998
1.7	Add 64-pin package		AUG/21/1998
1.8	Made for CD-ROM release		SEP/15/1998
1.9	Modify 64-pin package outline data		OCT/20/1998
2.0	64 PIN P-LQFP PACKAGE INFORMATION content changed	P16	OCT/27/1998
2.1	New revision adds E-channel monitoring function, extra SDS2 pin	P1,3,4,	APR/01/1999
2.2	Add one E-bit pin Add LQFP pin description Revise figure 8 Add LQFP package data Add more descriptions	P10~35	DEC/17/1999
2.3	Add Pre-Filter Compensation	P22	JAN/21/2000
2.4	Contents modify	P5,8	APR/28/2000
2.5	Modify state diagram 6-9(a)&6-9(b)	P23,24	SEP/05/2000



**PACKAGE INFORMATION**
**44-PIN PLASTIC LEADED CHIP CARRIER (PLCC)**

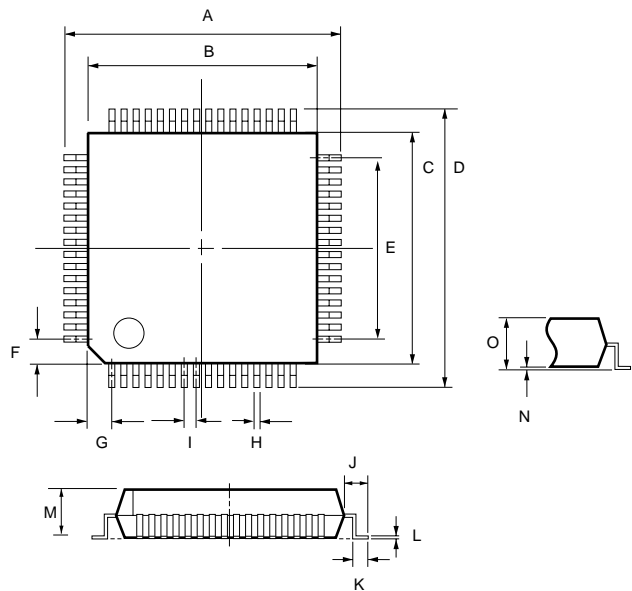
ITEM	MILLIMETERS	INCHES
A	17.53 ± .12	.699 ± .005
B	16.59 ± .12	.653 ± .12
C	16.59 ± .12	.653 ± .12
D	17.53 ± .12	.690 ± .12
E	1.95	.077
F	4.70 max.	.185 max.
G	2.55 ± .25	.100 ± .010
H	.51 min.	.020 min.
I	1.27 [Typ.]	.050 [Typ.]
J	.71 ± .10	.028 ± .004
K	.46 ± .10	.018 ± .004
L	15.50 ± .51	.610 ± .020
M	.53 R	.025 R
N	.25 [Typ.]	.010 [Typ.]

**NOTE:** Each lead centerline is located within .25 mm [.01 inch] of its true position [TP] at maximum material condition.


**64-PIN PLASTIC LOW-PROFILE QUAD FLAT PACKAGE (P-LQFP)**

ITEM	MILLIMETERS	INCHES
A	16	.63
B	14	.55
C	14	.55
D	16	.63
E	12 [Typ.]	.47 [Typ.]
F	1 [Typ.]	.039 [Typ.]
G	1 [Typ.]	.039 [Typ.]
H	.35 ± .05	.014 ± .002
I	0.8	.031
J	1	.039
K	.6 ± .15	.024 ± .006
L	.15 ± .05	.006 ± .002
M	1.4 ± .05	.057 ± .002
N	.1 ± .05	.004 ± .002
O	1.6 [max.]	.063 [max.]

**NOTE:** Each lead centerline is located within .25 mm [.01 inch] of its true position [TP] at maximum material condition.





**MX97102**

---

---

**MACRONIX INTERNATIONAL Co., LTD.**

**HEADQUARTERS:**

TEL:+886-3-578-6688

FAX:+886-3-563-2888

**EUROPE OFFICE:**

TEL:+32-2-456-8020

FAX:+32-2-456-8021

**JAPAN OFFICE:**

TEL:+81-44-246-9100

FAX:+81-44-246-9105

**SINGAPORE OFFICE:**

TEL:+65-348-8385

FAX:+65-348-8096

**TAIPEI OFFICE:**

TEL:+886-2-2509-3300

FAX:+886-2-2509-2200

**MACRONIX AMERICA, INC.**

TEL:+1-408-453-8088

FAX:+1-408-453-8488

**CHICAGO OFFICE:**

TEL:+1-847-963-1900

FAX:+1-847-963-1909

**<http://www.macronix.com>**

---