

# NIKO-SEM

## 5 Bit Programmable Synchronous DC/DC Controller

# N1153

### GENERAL DESCRIPTION

The N1153 is a low-cost, 5 bit TTL-compatible input, digital-to-analog (DAC) programmable, synchronous buck converter controller designed specifically to power the Pentium® II as well as the next generation of P6 family or other high performance core logic in desktop personal computer CPU applications.

Additional features also include temperature compensated voltage reference, triangle wave oscillator, current limits comparator, frequency shift over-current protection, and an accessible, internally compensated error amplifier, power good signal, logic compatible shutdown, and over voltage protection are also provide.

The N1153 operates at a fixed 200KHz, providing an optimum compromise between efficiency, external component size, and cost.

### FEATURES

- High performance and low cost solution
- Synchronous operation with high efficiency
- TTL-compatible 5 bit DAC, output voltage selection from 1.3V to 3.5V programmable
- High current totem pole output, up to 2 A for direct driving of the external N-Channel power MOSFETs.
- 200 KHz fixed frequency internal oscillator
- Fast transient response
- Power-Good output voltage monitor
- Over-Voltage and Over-Current protection

### APPLICATIONS

- Powering Pentium® II, III or Deschutes, K6 and other advanced processor
- Multiple microprocessor supplies
- High power DC to DC controller
- Programmable power supplies

### TYPICAL APPLICATION

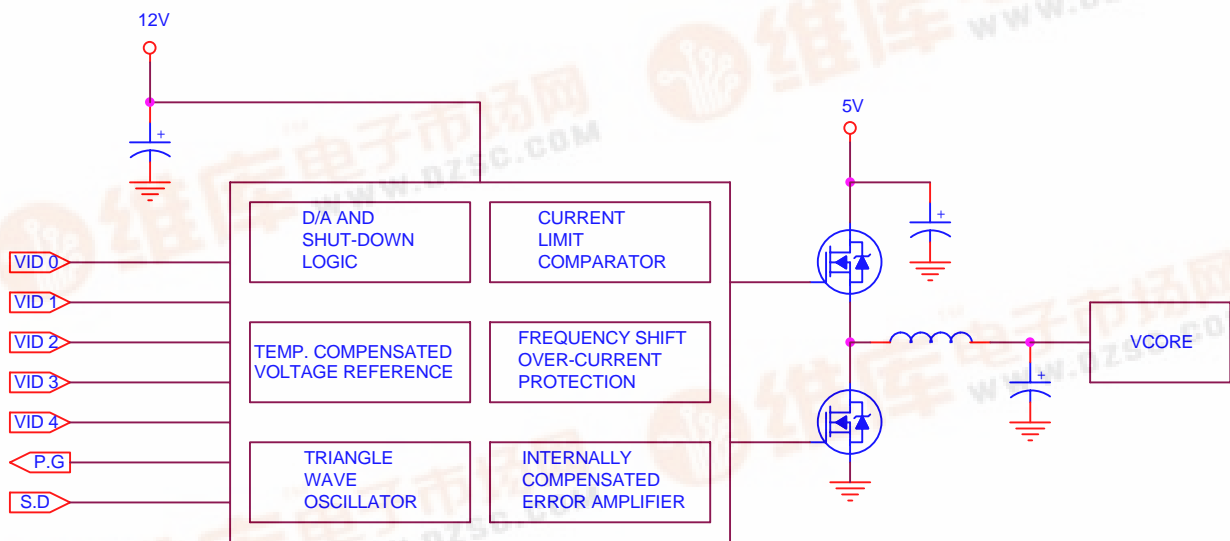

N1153, Motherboard Power Regulation for Computers

**ABSOLUTE MAXIMUM RATINGS**

● $V_{CC}$ to GND, $V_{IN}$	- 0.3V to 7V	● Operating Temperature Range, $T_A$	0 to 70 °C
● BST to GND	-0.3V to 15V	● Operating Junction Temperature Range, $T_J$	0 to 125 °C
● Thermal Resistance Junction to Case, $\theta_{JC}$	30 °C/W	● Storage Temperature Range, $T_{STG}$	-65 to 150 °C
● Thermal Resistance Junction to Ambient, $\theta_{JA}$	90 °C/W	● Lead Temperature, $T_{LEAD}$ (Soldering, 10 Seconds)	300 °C

**ELECTRICAL SPECIFICATIONS**

<Unless specified:  $V_{CC} = 4.75V \sim 5.25V$ ,  $GND = PGND = 0V$ ,  $V_{OSENSE} = V_O$ ,  $0mV < (CS^+ - CS^-) < 60mV$ ,  $T_A = 25^\circ C$ >

PARAMETER	CONDITIONS	MIN	TYP	MAX	UNITS
Supply Voltage	$V_{CC}$	4.2		7	V
Supply Current	$V_{CC} = 5.0V$		5		mA
Output Voltage	$I_O = 2A$	See Table 1.			
Load Regulation	$I_O = 0.3A$ to 15A		1		%
Line Regulation	All VID Codes		0.5		%
Gain ( $A_{OL}$ )	$V_{OSENSE}$ to $V_O$		35		dB
Current Limit Voltage		60	70	80	mV
Oscillator Frequency		180	200	220	KHz
Oscillator Max Duty Cycle		90	95		%
Peak DH Sink/Source Current	BSTH - DH = 4.5V, DH - PGNDH = 2V	1			A
Peak DL Sink/Source Current	BSTL - DL = 4.5V, DL - PGNDL = 2V	1			A
OVP Threshold Voltage			120		%
OVP Source Current	$V_{OVP} = 3.0V$	10			mA
Power-Good Threshold Voltage		85		115	%
Dead Time		100	200		nS

**PIN CONFIGURATIONS**

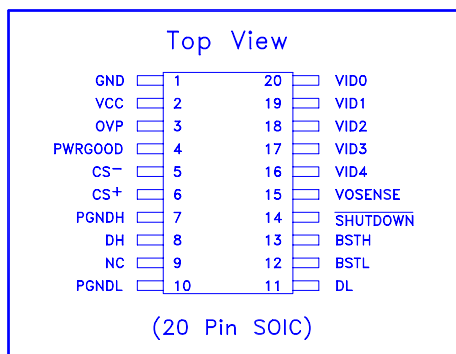

**PIN DEFINITIONS**

Pin #	Pin Name	Pin Function Description
1	GND	Small signal analog and digital ground
2	V <sub>CC</sub>	Input voltage
3	OVP	High signal out if V <sub>O</sub> >set point +20%
4	PWRGOOD*	Open collector logic output, high if V <sub>O</sub> within 10% of set point
5	CS <sup>-</sup>	Current sense input (Negative)
6	CS <sup>+</sup>	Current sense input (Positive)
7	PGNDL	Power ground for high side switch
8	DH	High side driver output
9	NC	No connected
10	PGNDL	Power ground for high side switch
11	DL	Low side driver output
12	BSTL	Supply for low side driver
13	BSTH	Supply for high side driver
14	SHUTDOWN	Logic low shuts down the converter
15	VOSENSE	Top end of internal feedback chain
16	VID4*	Programming input (MSB)
17	VID3*	Programming input
18	VID2*	Programming input
19	VID1*	Programming input
20	VID0*	Programming input (LSB)

\* : All logic level inputs and outputs are open collector TTL compatible.

**OUTPUT VOLTAGE**

<Unless specified:  $V_{CC} = 4.75V \sim 5.25V$ ,  $GND = PGND = 0V$ ,  $V_{OSENSE} = V_o$ ,  $0mV < (CS^+ - CS^-) < 60mV$ ,  $LDOV = 11.4V \sim 12.6V$ ,  $T_A = 25^\circ C$ >

– Table 1 –

VID 4 3 2 1 0	Min. (V)	Typ. (V)	Max. (V)
0 1 1 1 1	1.274	1.300	1.326
0 1 1 1 0	1.323	1.350	1.377
0 1 1 0 1	1.372	1.400	1.428
0 1 1 0 0	1.421	1.450	1.479
0 1 0 1 1	1.470	1.500	1.530
0 1 0 1 0	1.527	1.550	1.573
0 1 0 0 1	1.576	1.600	1.624
0 1 0 0 0	1.625	1.650	1.675
0 0 1 1 1	1.675	1.700	1.726
0 0 1 1 0	1.724	1.750	1.776
0 0 1 0 1	1.773	1.800	1.827
0 0 1 0 0	1.822	1.850	1.878
0 0 0 1 1	1.871	1.900	1.929
0 0 0 1 0	1.921	1.950	1.979
0 0 0 0 1	1.970	2.000	2.030
0 0 0 0 0	2.019	2.050	2.081
1 1 1 1 1	1.940	2.000	2.060
1 1 1 1 0	2.058	2.100	2.142
1 1 1 0 1	2.156	2.200	2.244
1 1 1 0 0	2.254	2.300	2.346
1 1 0 1 1	2.352	2.400	2.448
1 1 0 1 0	2.450	2.500	2.550
1 1 0 0 1	2.548	2.600	2.652
1 1 0 0 0	2.646	2.700	2.754
1 0 1 1 1	2.744	2.800	2.856
1 0 1 1 0	2.842	2.900	2.958
1 0 1 0 1	2.940	3.000	3.060
1 0 1 0 0	3.038	3.100	3.162
1 0 0 1 1	3.136	3.200	3.264
1 0 0 1 0	3.234	3.300	3.366
1 0 0 0 1	3.332	3.400	3.468
1 0 0 0 0	3.430	3.500	3.570

Note:  $I_o = 2.0A$  in Application Circuit

**APPLICATION CIRCUIT**

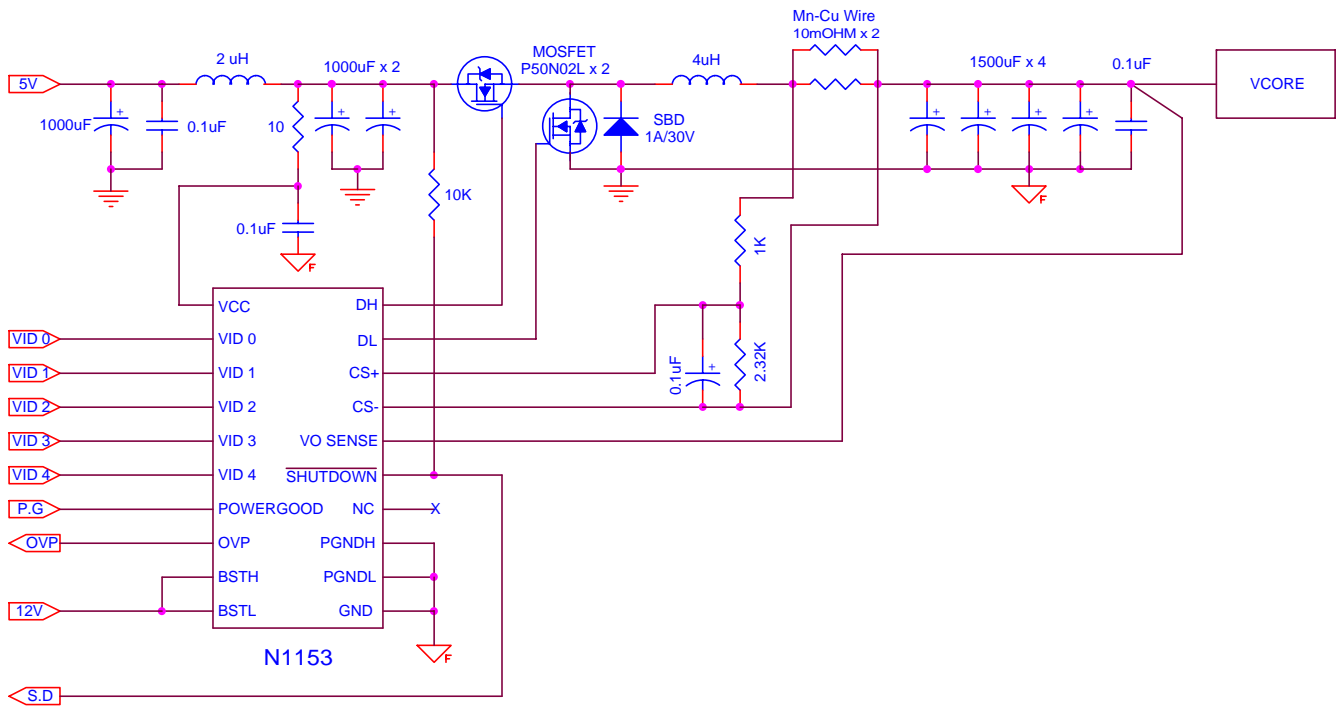

**SOIC-20 (DW) MECHANICAL DATA**

Dimension	mm			Dimension	mm		
	Min.	Typ.	Max.		Min.	Typ.	Max.
A	12.6		13.0	H	0.4		1.27
B	7.3		7.7	I	0.23		0.32
C	10		10.65	J	0.25		0.74
D	0.33		0.51	K	0°		8°
E		1.27		L			
F	2.1	2.3	2.5	M			
G	0.1		0.3	N			

