

TOSHIBA Transistor Silicon PNP Epitaxial Type (PCT Process)

**RN2114,RN2115,RN2116
RN2117,RN2118**

Switching, Inverter Circuit, Interface Circuit
And Driver Circuit Applications

- With built-in bias resistors
- Simplify circuit design
- Reduce a quantity of parts and manufacturing process
- Complementary to RN1114~RN1118

Equivalent Circuit and Bias Resister Values

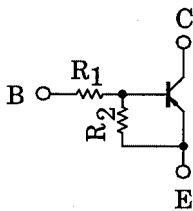

Type No.	R1 (kΩ)	R2 (kΩ)
RN2114	1	10
RN2115	2.2	10
RN2116	4.7	10
RN2117	10	4.7
RN2118	47	10

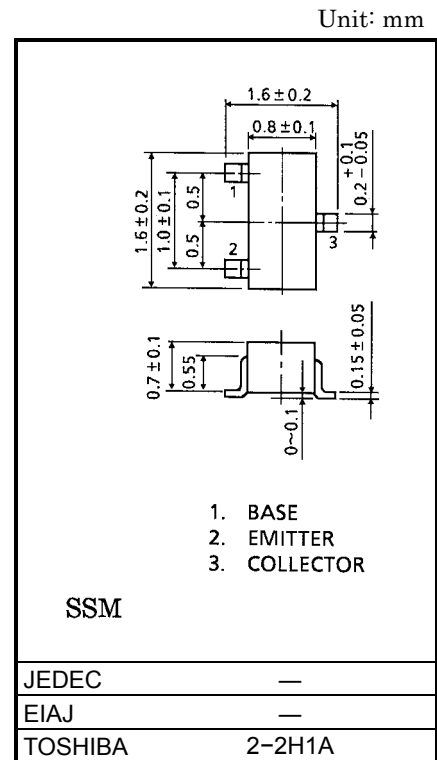

Weight: 2.4mg

Maximum Ratings (Ta = 25°C)

Characteristic	Symbol	Rating	Unit	
Collector-base voltage	RN2114~2118	V_{CB0}	-50	V
Collector-emitter voltage		V_{CEO}	-50	V
Emitter-base voltage	RN2114	V_{EBO}	-5	V
			-6	
			-7	
			-15	
			-25	
Collector current	RN2114~2118	I_C	-100	mA
Collector power dissipation		P_C	100	mW
Junction temperature		T_j	150	°C
Storage temperature range		T_{stg}	-55~150	°C

Electrical Characteristics (Ta = 25°C)

Characteristic		Symbol	Test Circuit	Test Condition	Min	Typ.	Max	Unit
Collector cut-off current	RN2114~2118	I_{CBO}	—	$V_{CB} = -50V, I_E = 0$	—	—	-100	nA
	RN2114~2118	I_{CEO}		$V_{CE} = -50V, I_B = 0$	—	—	-500	nA
Emitter cut-off current	RN2114	I_{EBO}	—	$V_{EB} = -5V, I_C = 0$	-0.35	—	-0.65	mA
	RN2115			$V_{EB} = -6V, I_C = 0$	-0.37	—	-0.71	
	RN2116			$V_{EB} = -7V, I_C = 0$	-0.36	—	-0.68	
	RN2117			$V_{EB} = -15V, I_C = 0$	-0.78	—	-1.46	
	RN2118			$V_{EB} = -25V, I_C = 0$	-0.33	—	-0.63	
DC current gain	RN2114~16 18	h_{FE}	—	$V_{CE} = -5V, I_C = -10mA$	50	—	—	—
	RN2117				30	—	—	
Collector-emitter saturation voltage	RN2114~2118	$V_{CE(sat)}$	—	$I_C = -5mA, I_B = -0.25mA$	—	-0.1	-0.3	V
Input voltage (ON)	RN2114	$V_{I(ON)}$	—	$V_{CE} = -0.2V, I_C = -5mA$	-0.5	—	-2.0	V
	RN2115				-0.6	—	-2.5	
	RN2116				-0.7	—	-2.5	
	RN2117				-1.5	—	-3.5	
	RN2118				-2.5	—	-10.0	
Input voltage (OFF)	RN2114	$V_{I(OFF)}$	—	$V_{CE} = -5V, I_C = -0.1mA$	-0.3	—	-0.9	V
	RN2115				-0.3	—	-1.0	
	RN2116				-0.3	—	-1.1	
	RN2117				-0.3	—	-3.0	
	RN2118				-0.5	—	-5.7	
Transition frequency	RN2114~2118	f_T	—	$V_{CE} = -10V, I_C = -5mA$	—	200	—	MHz
Collector Output capacitance	RN2114~2118	C_{ob}	—	$V_{CB} = -10V, I_E = 0, f = 1MHz$	—	3.0	6.0	pF
Input resistor	RN2114	R1	—	—	0.7	1.0	1.3	kΩ
	RN2115				1.54	2.2	2.86	
	RN2116				3.29	4.7	6.11	
	RN2117				7.0	10.0	13.0	
	RN2118				32.9	47.0	61.1	
Resistor ratio	RN2114	R1/R2	—	—	—	0.1	—	—
	RN2115				—	0.22	—	
	RN2116				—	0.47	—	
	RN2117				—	2.13	—	
	RN2118				—	4.7	—	

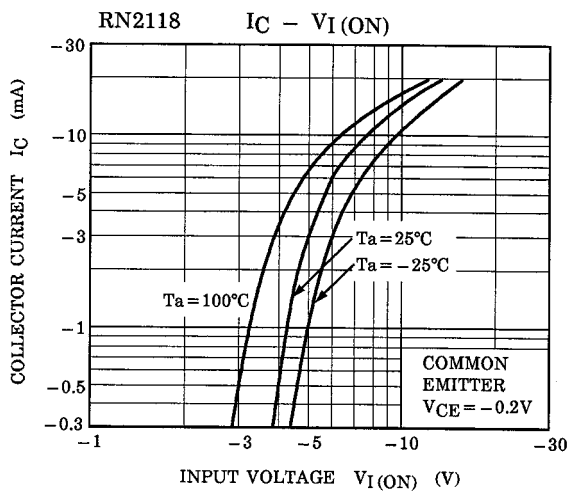
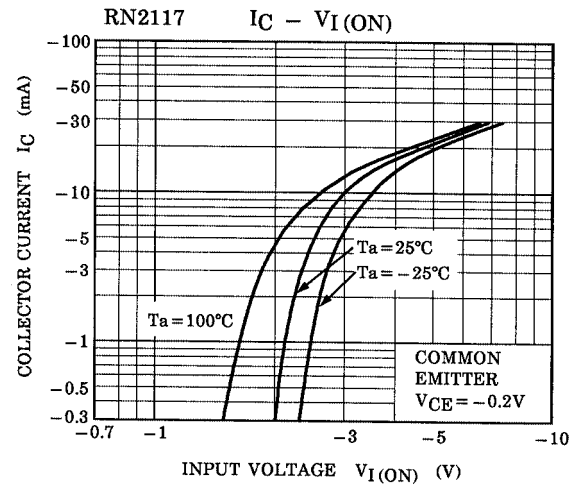
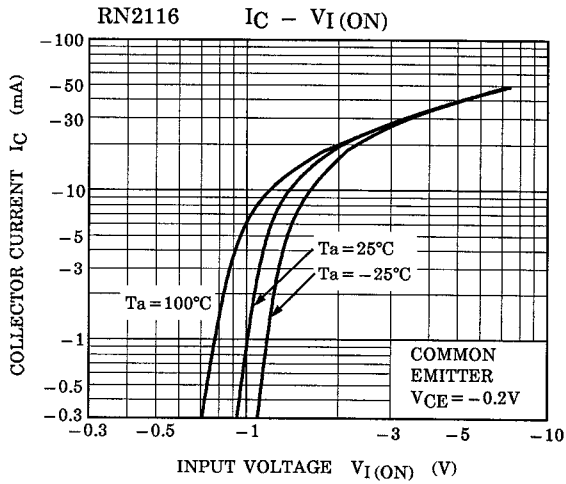
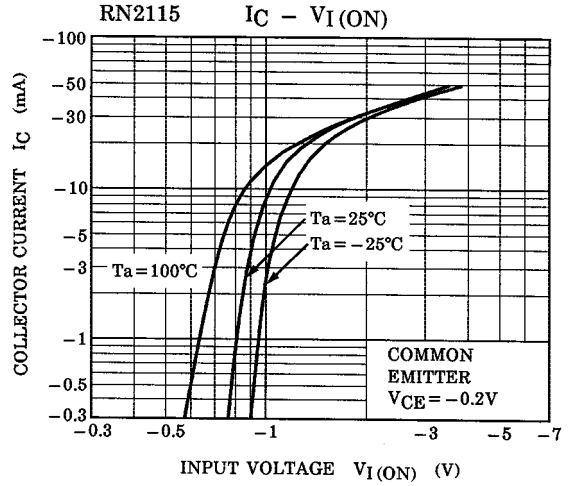
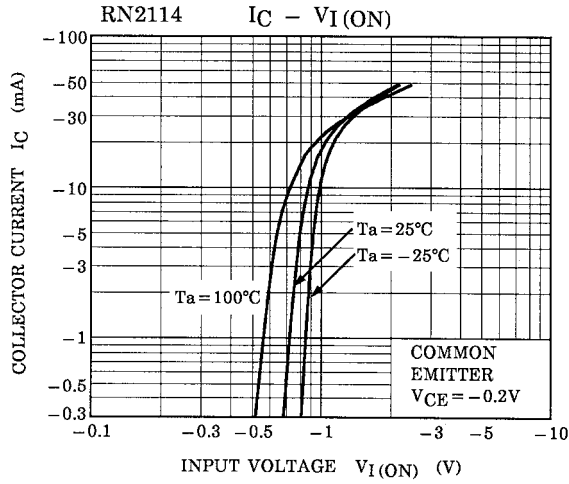

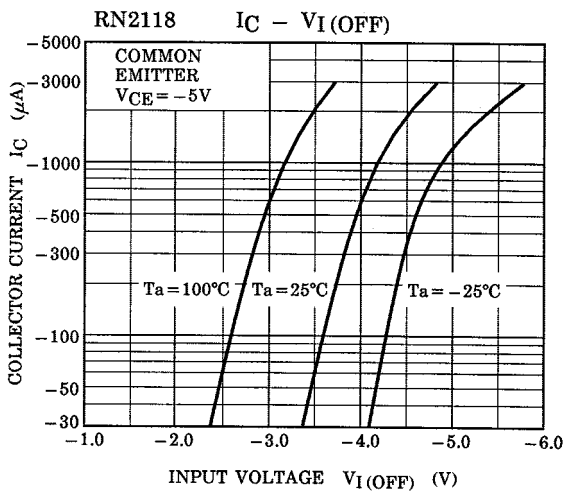
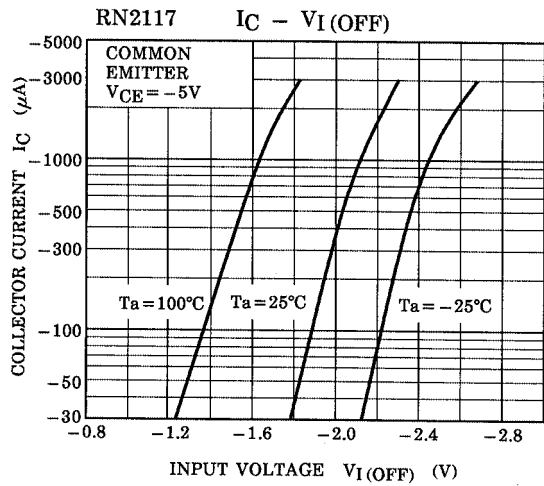
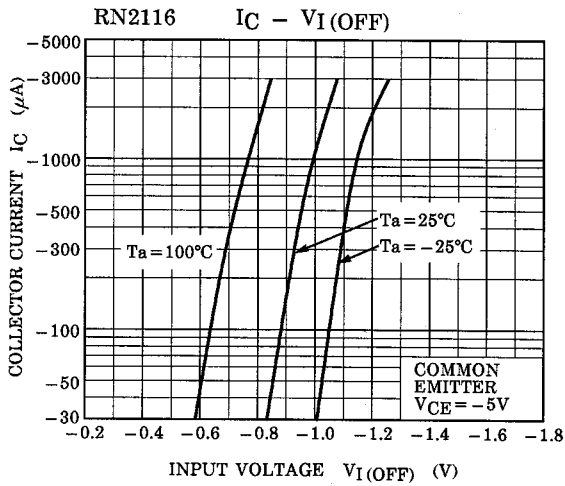
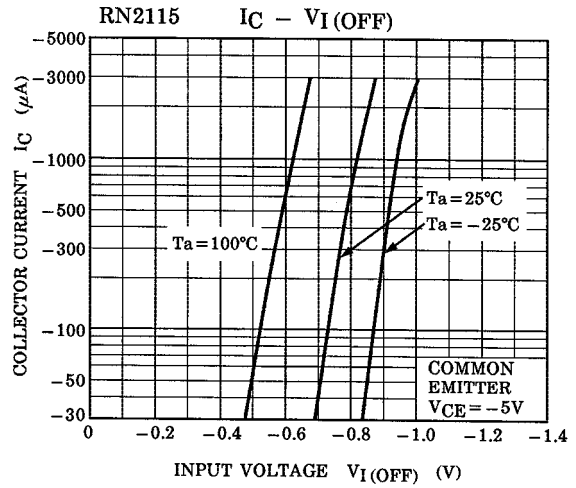
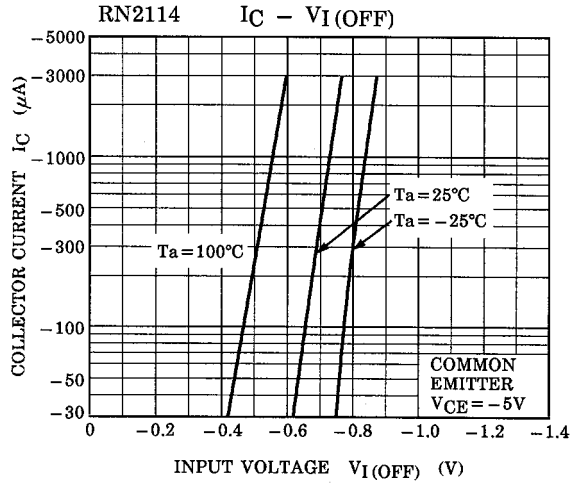

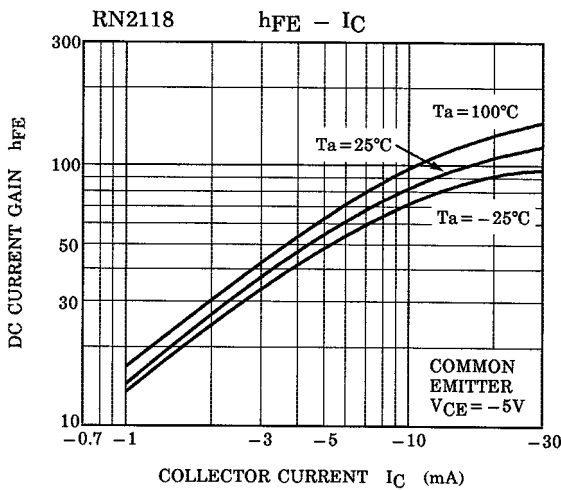
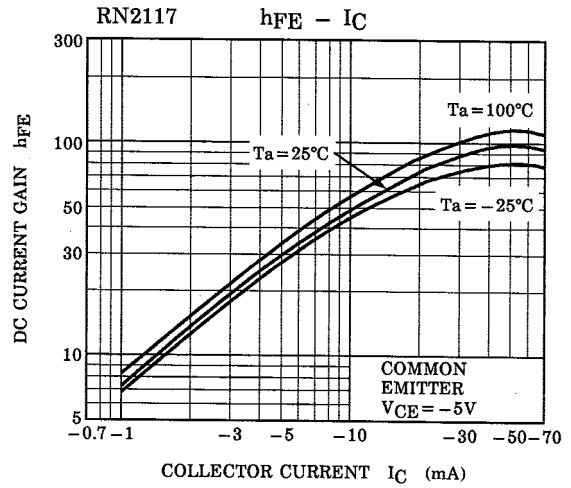
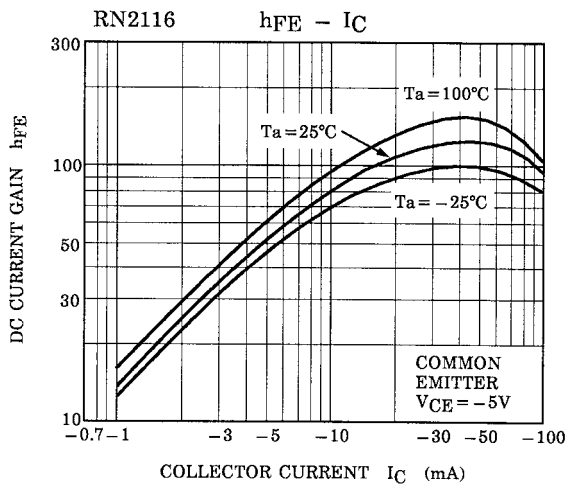
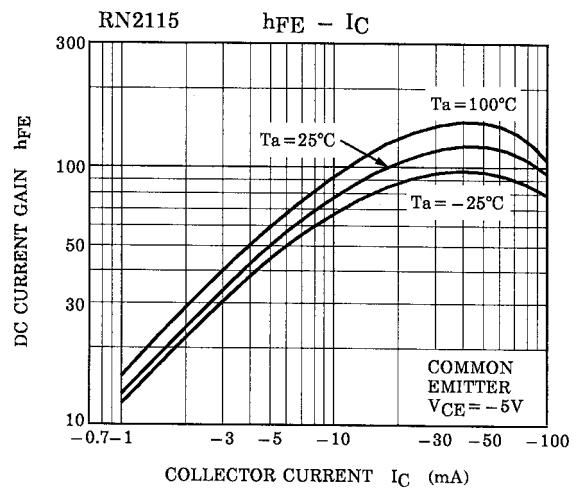
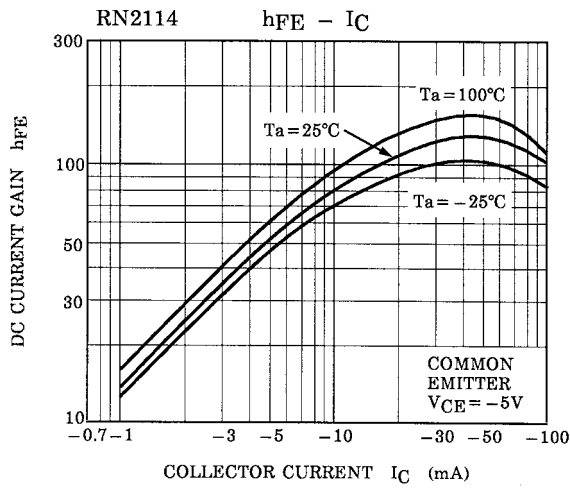

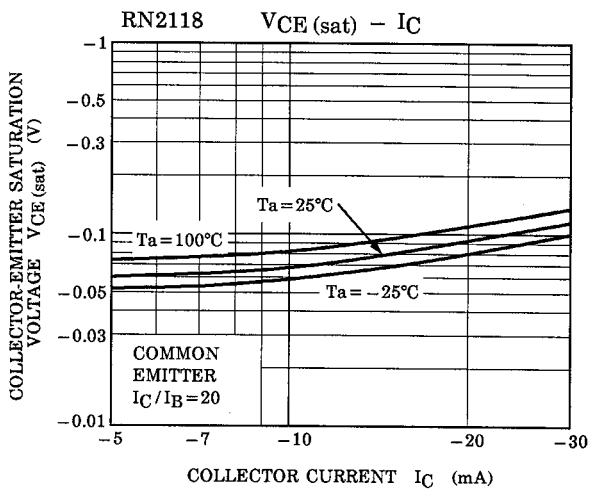
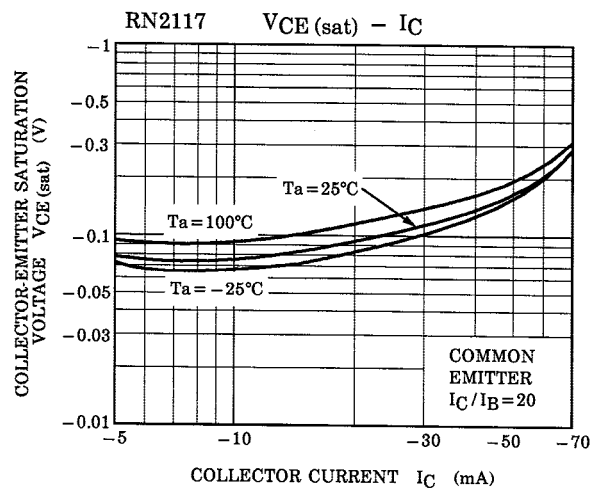
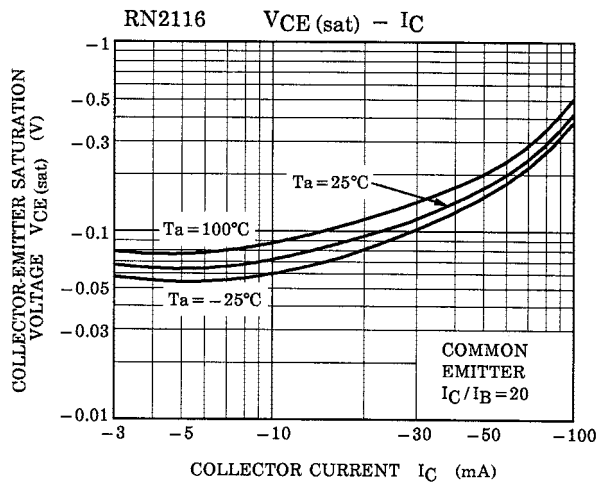
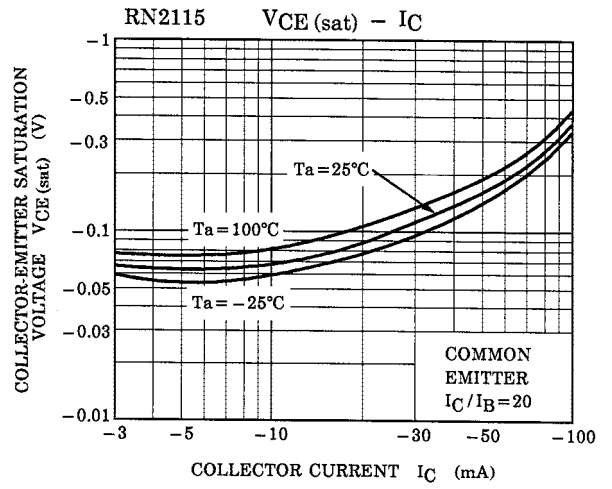
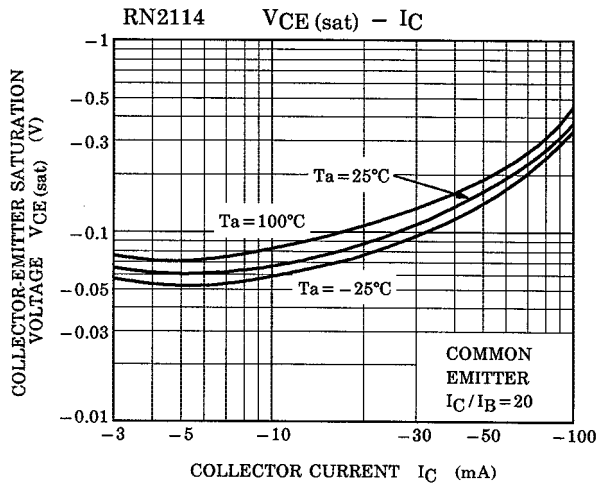

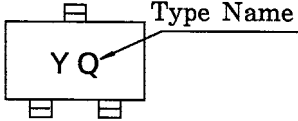
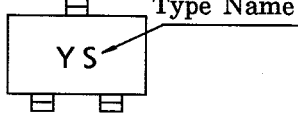
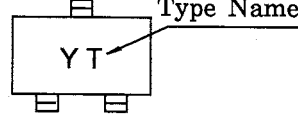
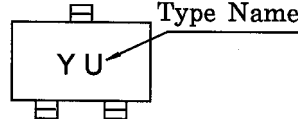
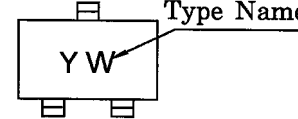
Type Name	Marking
RN2114	
RN2115	
RN2116	
RN2117	
RN2118	

RESTRICTIONS ON PRODUCT USE

000707EAA

- TOSHIBA is continually working to improve the quality and reliability of its products. Nevertheless, semiconductor devices in general can malfunction or fail due to their inherent electrical sensitivity and vulnerability to physical stress. It is the responsibility of the buyer, when utilizing TOSHIBA products, to comply with the standards of safety in making a safe design for the entire system, and to avoid situations in which a malfunction or failure of such TOSHIBA products could cause loss of human life, bodily injury or damage to property.
In developing your designs, please ensure that TOSHIBA products are used within specified operating ranges as set forth in the most recent TOSHIBA products specifications. Also, please keep in mind the precautions and conditions set forth in the "Handling Guide for Semiconductor Devices," or "TOSHIBA Semiconductor Reliability Handbook" etc..
- The TOSHIBA products listed in this document are intended for usage in general electronics applications (computer, personal equipment, office equipment, measuring equipment, industrial robotics, domestic appliances, etc.). These TOSHIBA products are neither intended nor warranted for usage in equipment that requires extraordinarily high quality and/or reliability or a malfunction or failure of which may cause loss of human life or bodily injury ("Unintended Usage"). Unintended Usage include atomic energy control instruments, airplane or spaceship instruments, transportation instruments, traffic signal instruments, combustion control instruments, medical instruments, all types of safety devices, etc.. Unintended Usage of TOSHIBA products listed in this document shall be made at the customer's own risk.
- The information contained herein is presented only as a guide for the applications of our products. No responsibility is assumed by TOSHIBA CORPORATION for any infringements of intellectual property or other rights of the third parties which may result from its use. No license is granted by implication or otherwise under any intellectual property or other rights of TOSHIBA CORPORATION or others.
- The information contained herein is subject to change without notice.

Copyright Each Manufacturing Company.

All Datasheets cannot be modified without permission.

This datasheet has been download from :

www.AllDataSheet.com

100% Free DataSheet Search Site.

Free Download.

No Register.

Fast Search System.

www.AllDataSheet.com