



INA138
INA168

For most current data sheet and other product information, visit www.burr-brown.com

High-Side Measurement CURRENT SHUNT MONITOR

FEATURES

- COMPLETE UNIPOLAR HIGH-SIDE CURRENT MEASUREMENT CIRCUIT
- WIDE SUPPLY AND COMMON-MODE RANGE
- INA138: 2.7V to 36V
- INA168: 2.7V to 60V
- INDEPENDENT SUPPLY AND INPUT COMMON-MODE VOLTAGES
- SINGLE RESISTOR GAIN SET
- LOW QUIESCENT CURRENT (25µA typ)
- SOT23-5 Package

APPLICATIONS

- CURRENT SHUNT MEASUREMENT
Automotive, Telephone, Computers
- PORTABLE & BATTERY BACKUP SYSTEMS
- BATTERY CHARGERS
- POWER MANAGEMENT
- CELL PHONES
- PRECISION CURRENT SOURCE

DESCRIPTION

The INA138 and INA168 are high-side, unipolar, current shunt monitors. Wide input common-mode voltage range, low quiescent current, and tiny SOT-23 packaging enable use in a variety of applications.

Input common-mode and power supply voltages are independent and can range from 2.7V to 36V for the INA138 and 2.7V to 60V for the INA168. Both models draw only 25µA quiescent current, which also permits connecting the power supply to either side of the current measurement shunt with minimal error.

The device converts a differential input voltage to a current output. This current is converted back to a voltage with an external load resistor that sets any gain from 1 to over 100. Although designed for current shunt measurement, the circuit invites creative applications in measurement and level shifting.

Both the INA138 and INA168 are available in SOT23-5 and are specified for the -40°C to +85°C industrial temperature range.

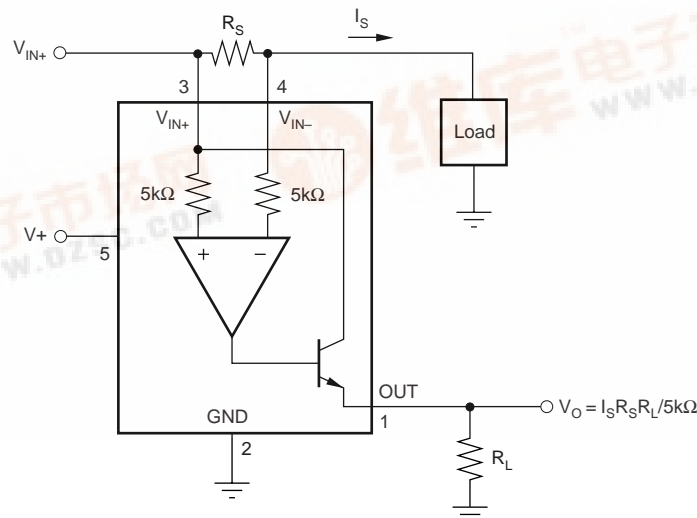

SPECIFICATIONS

At $T_A = -40^\circ\text{C}$ to $+85^\circ\text{C}$, $V_S = 5\text{V}$, $V_{IN+} = 12\text{V}$, $R_{OUT} = 125\text{k}\Omega$, unless otherwise noted.

PARAMETER	CONDITION	INA138			INA168			UNITS
		MIN	TYP	MAX	MIN	TYP	MAX	
INPUT								
Full-Scale Sense Voltage	$V_{SENSE} = V_{IN+} - V_{IN-}$		100	500	*	*	*	mV
Common-Mode Input Range		2.7		36	*			V
Common-Mode Rejection	$V_{IN+} = 2.7\text{V}$ to 40V , $V_{SENSE} = 50\text{mV}$ $V_{IN+} = 2.7\text{V}$ to 60V , $V_{SENSE} = 50\text{mV}$	100	120		100	120		dB
Offset Voltage ⁽¹⁾			± 0.2	± 1		*	*	mV
vs Temperature	T_{MIN} to T_{MAX}		1			*		$\mu\text{V}/^\circ\text{C}$
vs Power Supply	$V_- = 2.7\text{V}$ to 40V , $V_{SENSE} = 50\text{mV}$ $V_- = 2.7\text{V}$ to 60V , $V_{SENSE} = 50\text{mV}$		0.1	10		0.1	10	$\mu\text{V}/\text{V}$
Input Bias Current	V_{IN+} , V_{IN-}		2			*		μA
OUTPUT								
Transconductance	$V_{SENSE} = 10\text{mV} - 150\text{mV}$	198	200	202	*	*	*	$\mu\text{A}/\text{V}$
vs Temperature	$V_{SENSE} = 100\text{mV}$		10			*		$\text{nA}/^\circ\text{C}$
Nonlinearity Error	$V_{SENSE} = 10\text{mV}$ to 150mV		± 0.01	± 0.1		*	*	%
Total Output Error	$V_{SENSE} = 100\text{mV}$		± 0.5	± 2		*	*	%
Output Impedance			1 5			*		$\text{G}\Omega$ pF
Voltage Output						*	*	V
Swing to Power Supply, V_+			$(V_+) - 0.8$	$(V_+) - 1.0$		*	*	V
Swing to Common Mode, V_{CM}			$V_{CM} - 0.5$	$V_{CM} - 0.8$		*	*	V
FREQUENCY RESPONSE								
Bandwidth	$R_{OUT} = 5\text{k}\Omega$		800			*		kHz
	$R_{OUT} = 125\text{k}\Omega$		32			*		kHz
Settling Time (0.1%)	5V Step, $R_{OUT} = 5\text{k}\Omega$		1.8			*		μs
	5V Step, $R_{OUT} = 125\text{k}\Omega$		30			*		μs
NOISE								
Output-Current Noise Density			9			*		$\text{pA}/\sqrt{\text{Hz}}$
Total Output-Current Noise	BW = 100kHz		3			*		nA RMS
POWER SUPPLY								
Operating Range, V_+		2.7		36	*		60	V
Quiescent Current	$V_{SENSE} = 0$, $I_O = 0$		25	45		*	*	μA
TEMPERATURE RANGE								
Specification, T_{MIN} to T_{MAX}		-40		85	*		*	$^\circ\text{C}$
Operating		-55		125	*		*	$^\circ\text{C}$
Storage		-65		150	*		*	$^\circ\text{C}$
Thermal Resistance θ_{JA}			200			*		$^\circ\text{C}/\text{W}$

NOTES: (1) Defined as the amount of input voltage, V_{SENSE} , to drive the output to zero.

PIN CONFIGURATION

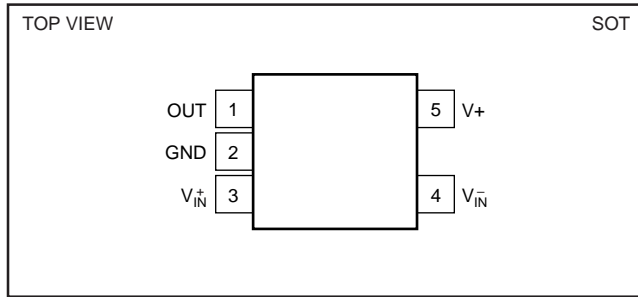

ELECTROSTATIC DISCHARGE SENSITIVITY

This integrated circuit can be damaged by ESD. Burr-Brown recommends that all integrated circuits be handled with appropriate precautions. Failure to observe proper handling and installation procedures can cause damage.

ESD damage can range from subtle performance degradation to complete device failure. Precision integrated circuits may be more susceptible to damage because very small parametric changes could cause the device not to meet its published specifications.

ABSOLUTE MAXIMUM RATINGS⁽¹⁾

Supply Voltage, V+	
INA138	-0.3V to 60V
INA168	-0.3V to 60V
Analog Inputs, V _{IN+} , V _{IN-}	
INA138	
Common Mode	-0.3V to 40V
Differential (V _{IN+}) - (V _{IN-})	-40V to 2V
INA168	
Common Mode	-0.3V to 60V
Differential (V _{IN+}) - (V _{IN-})	-40V to 2V
Analog Output, Out	-0.3V to 40V
Operating Temperature	-55°C to +125°C
Storage Temperature	-55°C to +125°C
Junction Temperature	+150°C
Lead Temperature (soldering, 10s)	+300°C

NOTE: (1) Stresses above these ratings may cause permanent damage. Exposure to absolute maximum conditions for extended periods may degrade device reliability. These are stress ratings only, and functional operation of the device at these or any other conditions beyond those specified is not implied.

PACKAGE/ORDERING INFORMATION

PRODUCT	PACKAGE	PACKAGE DRAWING NUMBER	SPECIFIED TEMPERATURE RANGE	PACKAGE MARKING	ORDERING NUMBER ⁽¹⁾	TRANSPORT MEDIA
INA138NA	SOT-23-5 Surface Mount	331	-40°C to +85°C	"	INA138NA/250	Tape and Reel
"	"	"	"	"	INA138NA/3K	Tape and Reel
INA168NA ⁽²⁾	SOT-23-5 Surface Mount	331	-40°C to +85°C	"	INA168NA/250	Tape and Reel
"	"	"	"	"	INA168NA/3K	Tape and Reel

NOTE: (1) Models with a slash (/) are available only in Tape and Reel in the quantities indicated (e.g., /3K indicates 3000 devices per reel). Ordering 3000 pieces of "INA138NA/3K" will get a single 3000-piece Tape and Reel. (2) INA168 available Q2'00.

TYPICAL PERFORMANCE CURVES

At $T_A = +25^\circ\text{C}$, $V_+ = 5\text{V}$, $V_{IN} = 12\text{V}$, $R_L = 125\text{k}\Omega$, unless otherwise noted.

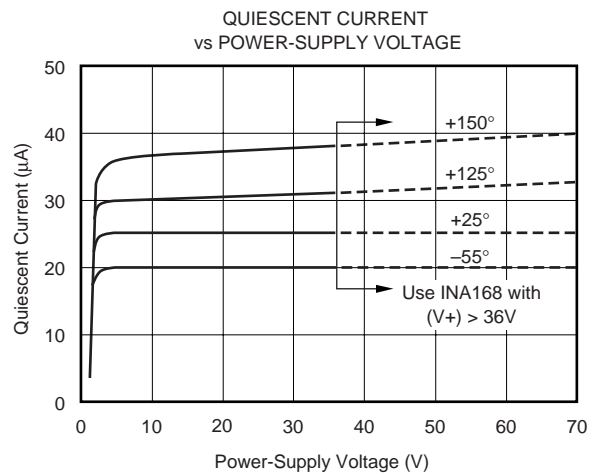
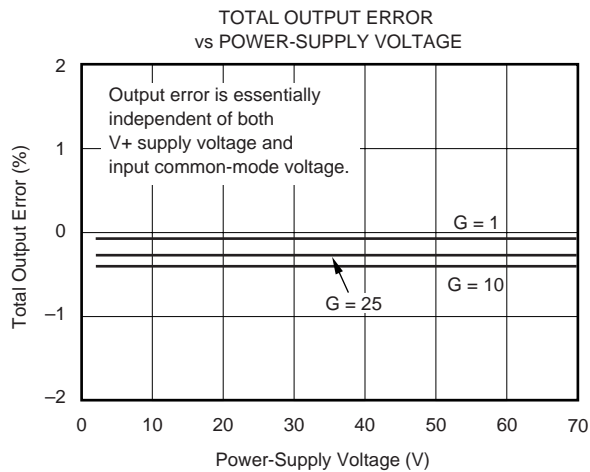
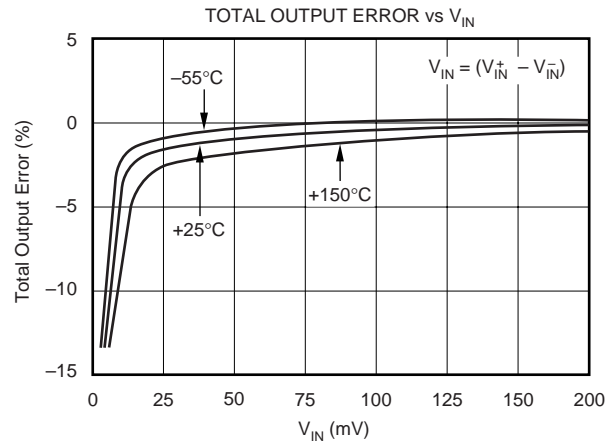
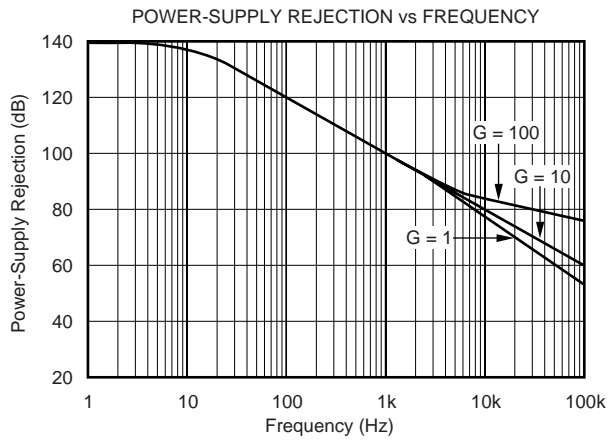
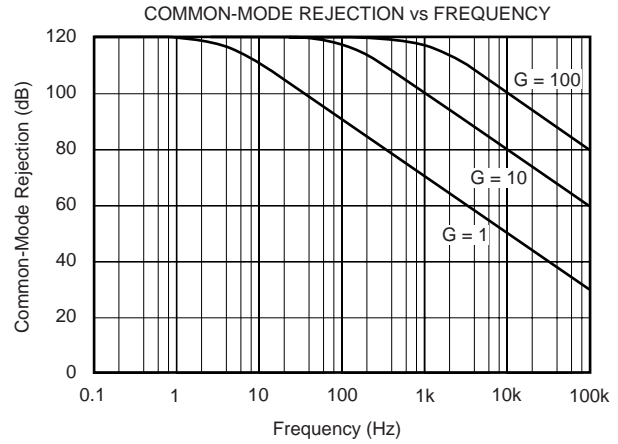
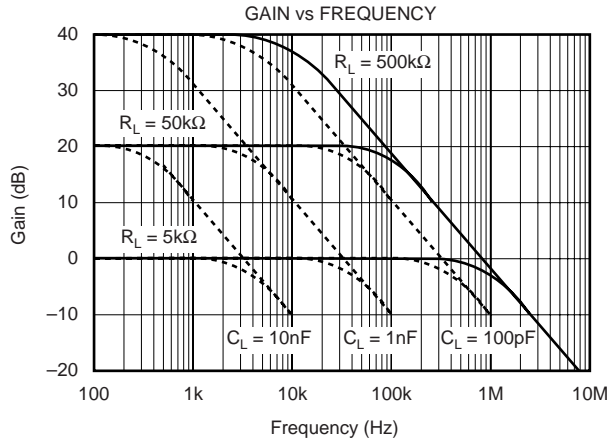

TYPICAL PERFORMANCE CURVES (Cont.)

At $T_A = +25^\circ\text{C}$, $V_+ = 5\text{V}$, $V_{IN} = 12\text{V}$, $R_L = 125\text{k}\Omega$, unless otherwise noted.

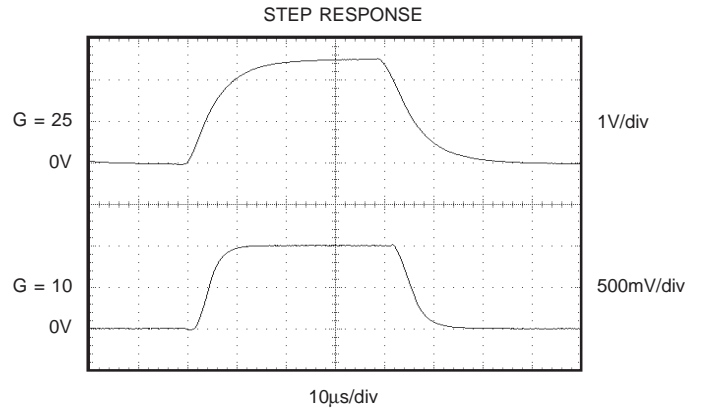
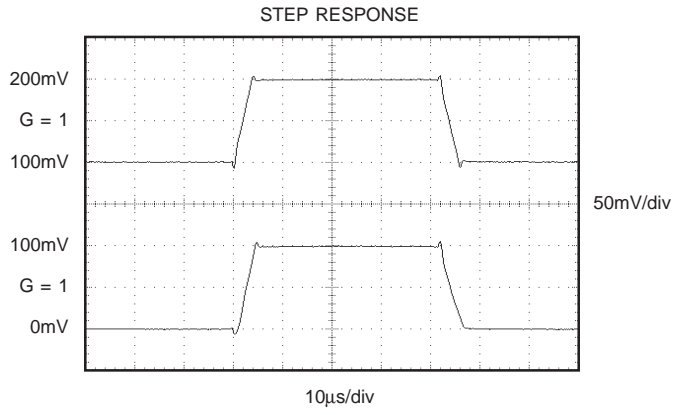

OPERATION

Figure 1 shows the basic circuit diagram for both the INA138 and INA168. Load current, I_S , is drawn from supply, V_S , through shunt resistor, R_S . The voltage drop in the shunt resistor, V_S , is forced across R_{G1} by the internal op-amp, causing current to flow into the collector of Q1. External resistor, R_L , converts the output current to a voltage, V_{OUT} , at the Out pin.

The transfer function for the INA138 is:

$$I_O = g_m (V_{IN}^+ - V_{IN}^-) \quad (1)$$

$$\text{where } g_m = 200\mu\text{A/V} \quad (2)$$

In the circuit of Figure 1, the input voltage, $(V_{IN}^+ - V_{IN}^-)$, is equal to $I_S \cdot R_S$ and the output voltage, V_{OUT} , is equal to $I_O \cdot R_L$. The transconductance, g_m , of the INA138 is $200\mu\text{A/V}$. The complete transfer function for the current measurement amplifier in this application is:

$$V_{OUT} = (I_S) (R_S) (200\mu\text{A/V}) (R_L) \quad (3)$$

The maximum differential input voltage for accurate measurements is 0.5V, which produces a $100\mu\text{A}$ output current. A differential input voltage of up to 2V will not cause damage. Differential measurements (pins 3 and 4) must be unipolar with a more-positive voltage applied to pin 3. If a more-negative voltage is applied to pin 3, the output current, I_O , will be zero, but it will not cause damage.

BASIC CONNECTION

Figure 1 shows the basic connection of the INA138. The input pins, V_{IN}^+ and V_{IN}^- , should be connected as closely as possible to the shunt resistor to minimize any resistance in series with the shunt resistance. The output resistor, R_L , is shown connected between pin 1 and ground. Best accuracy is achieved with the output voltage measured directly across R_L . This is especially important in high-current systems where load current could flow in the ground connections, affecting the measurement accuracy.

No power supply bypass capacitors are required for stability of the INA138. However, applications with noisy or high impedance power supplies may require de-coupling capacitors to reject power supply noise. Connect bypass capacitors close to the device pins.

POWER SUPPLIES

The input circuitry of the INA138 can accurately measure beyond its power supply voltage, $V+$. For example, the $V+$ power supply can be 5V while the load power supply is voltage is up to +36V (or +60V with INA168). However, the output voltage range of the Out terminal is limited by the lesser of the two voltages (see "Output Voltage Range").

SELECTING R_S AND R_L

The value chosen for the shunt resistor, R_S , depends on the application and is a compromise between small-signal accuracy and maximum permissible voltage loss in the measurement line. High values of R_S provide better accuracy at

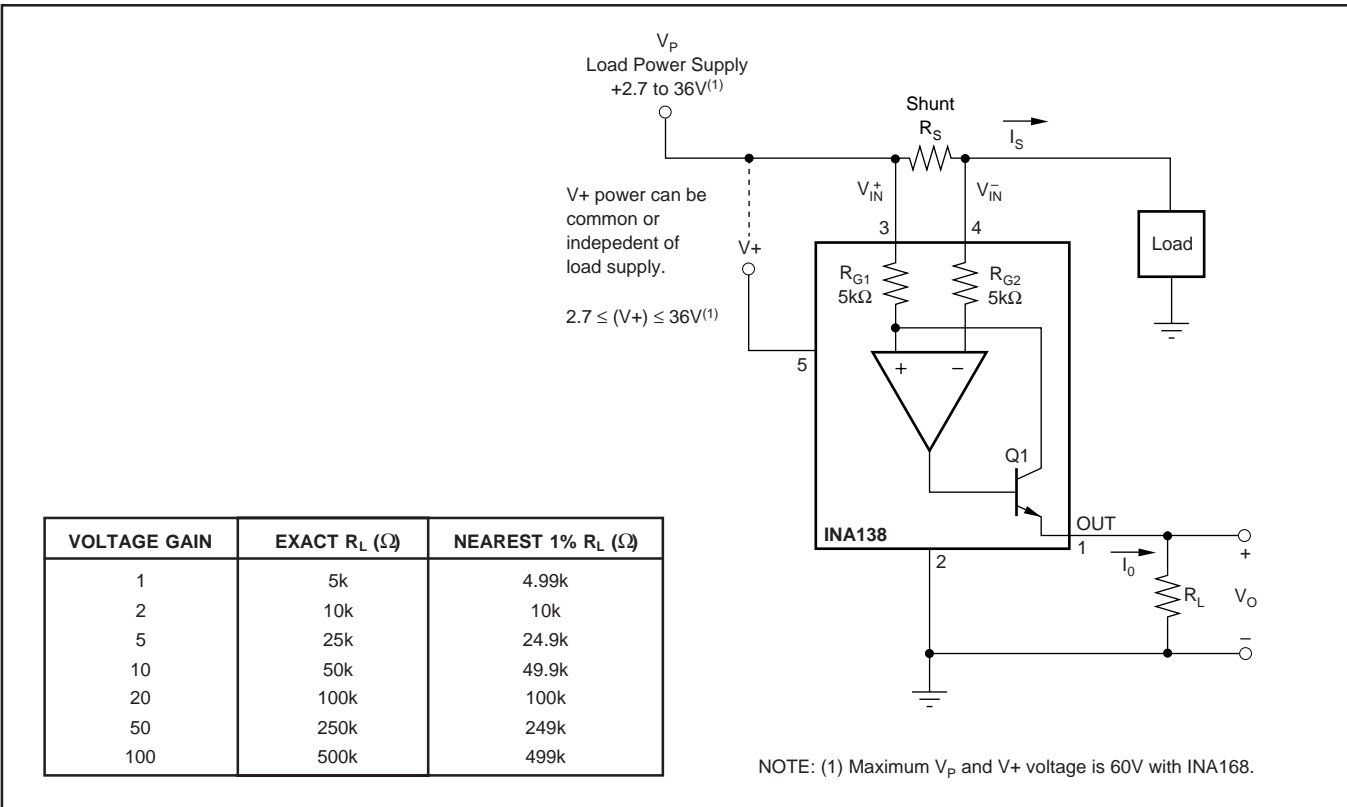

FIGURE 1. Basic Circuit Connections.

lower currents by minimizing the effects of offset, while low values of R_S minimize voltage loss in the supply line. For most applications, best performance is attained with an R_S value that provides a full-scale shunt voltage of 50mV to 100mV. Maximum input voltage for accurate measurements is 500mV.

R_L is chosen to provide the desired full-scale output voltage. The output impedance of the INA138 Out terminal is very high which permits using values of R_L up to 500k Ω with excellent accuracy. The input impedance of any additional circuitry at the output should be much higher than the value of R_L to avoid degrading accuracy.

Some A/D converters have input impedances that will significantly affect measurement gain. The input impedance of the A/D converter can be included as part of the effective R_L if its input can be modeled as a resistor to ground. Alternatively, an op-amp can be used to buffer the A/D converter input. See Figure 1 for recommended values of R_L .

OUTPUT VOLTAGE RANGE

The output of the INA138 is a current, which is converted to a voltage by the load resistor, R_L . The output current remains accurate within the *compliance voltage range* of the output circuitry. The shunt voltage and the input common-mode and power supply voltages limit the maximum possible

output swing. The maximum output voltage compliance is limited by the lower of the two equations below:

$$V_{out\ max} = (V+) - 0.7V - (V_{IN}^+ - V_{IN}^-) \quad (4)$$

or

$$V_{out\ max} = V_{IN}^- - 0.5V \quad (5)$$

(whichever is lower)

BANDWIDTH

Measurement bandwidth is affected by the value of the load resistor, R_L . High gain produced by high values of R_L will yield a narrower measurement bandwidth (see Typical Performance Curves). For widest possible bandwidth, keep the capacitive load on the output to a minimum. Reduction in bandwidth due to capacitive load is shown in the Typical Performance Curves.

If bandwidth limiting (filtering) is desired, a capacitor can be added to the output, as shown in Figure 3. This will not cause instability.

APPLICATIONS

The INA138 is designed for current shunt measurement circuits as shown in Figure 1, but its basic function is useful in a wide range of circuitry. A creative engineer will find many unforeseen uses in measurement and level shifting circuits. A few ideas are shown.

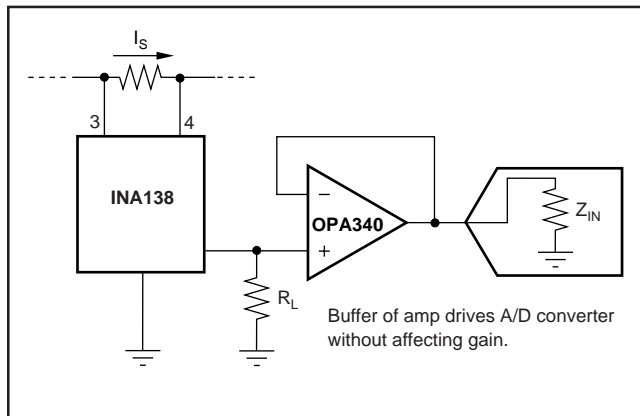

FIGURE 2. Buffering Output to Drive A/D Converter.

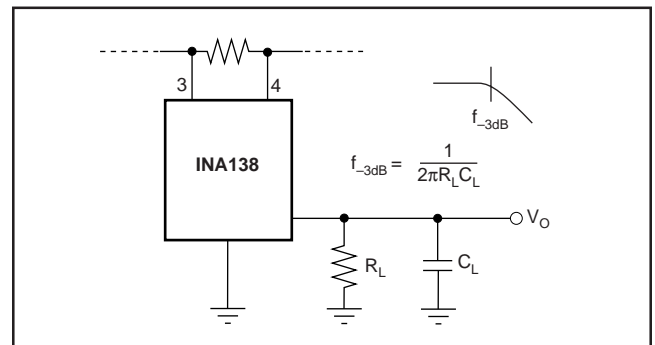

FIGURE 3. Output Filter.

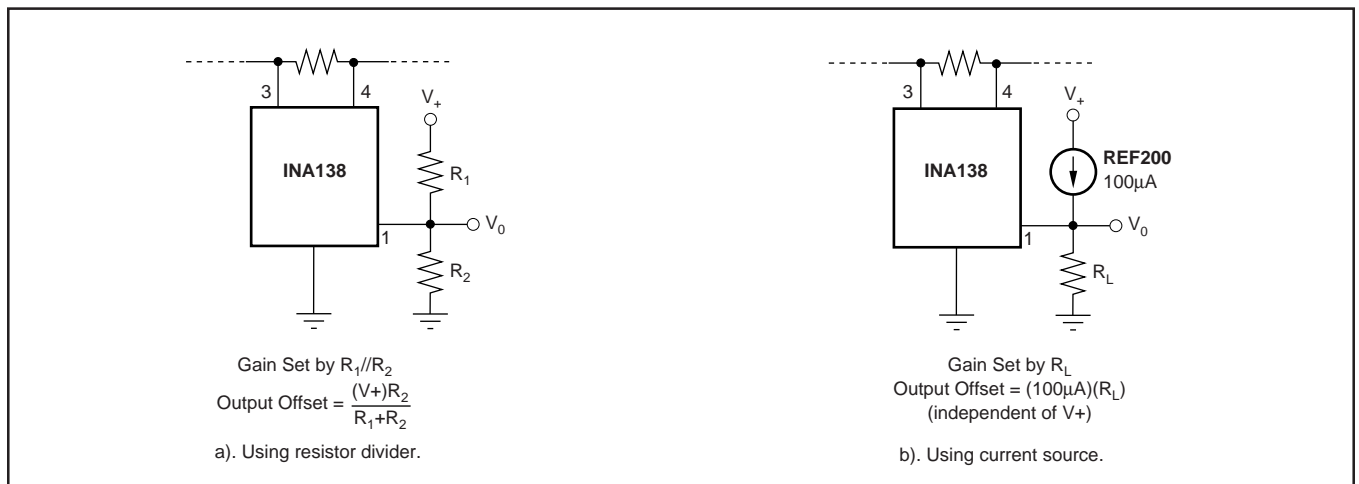

FIGURE 4. Offsetting the Output Voltage