



INA2132

Dual, Low Power, Single-Supply DIFFERENCE AMPLIFIER

FEATURES

- DESIGNED FOR LOW COST
- LOW QUIESCENT CURRENT:
160µA per Amplifier
- WIDE POWER SUPPLY RANGE:
Single Supply: 2.7V to 36V
Dual Supplies: ±1.35V to ±18V
- LOW GAIN ERROR: ±0.05% max
- LOW NONLINEARITY: 0.001% max
- HIGH CMRR: 90dB
- HIGHLY VERSATILE CIRCUIT
- EASY TO USE
- SO-14 PACKAGE

APPLICATIONS

- DIFFERENTIAL INPUT AMPLIFIER
- INSTRUMENTATION AMPLIFIER
BUILDING BLOCK
- UNITY-GAIN INVERTING AMPLIFIER
- G = 1/2 AMPLIFIER
- G = 2 AMPLIFIER
- SUMMING AMPLIFIER
- DIFFERENTIAL CURRENT RECEIVER
- VOLTAGE-CONTROLLED CURRENT SOURCE
- BATTERY-POWERED SYSTEMS
- GROUND LOOP ELIMINATOR

DESCRIPTION

The INA2132 is a dual low power, unity-gain difference amplifier offering excellent value at very low cost. Each channel consists of a precision op amp with a laser-trimmed precision resistor network, providing accurate gain and high common-mode rejection. Excellent TCR tracking of the resistors maintains gain accuracy and common-mode rejection over temperature. The internal op amp's common-mode range extends to the negative supply—ideal for single-supply applications.

The difference amplifier is the foundation of many commonly used circuits. The INA2132 provides this circuit function without using an expensive precision resistor network. The INA2132 is available in the SO-14 surface-mount package and is specified for operation over the extended industrial temperature range, -40°C to +85°C.

A single version of this product with similar specifications is also available. See the INA132 data sheet for details.

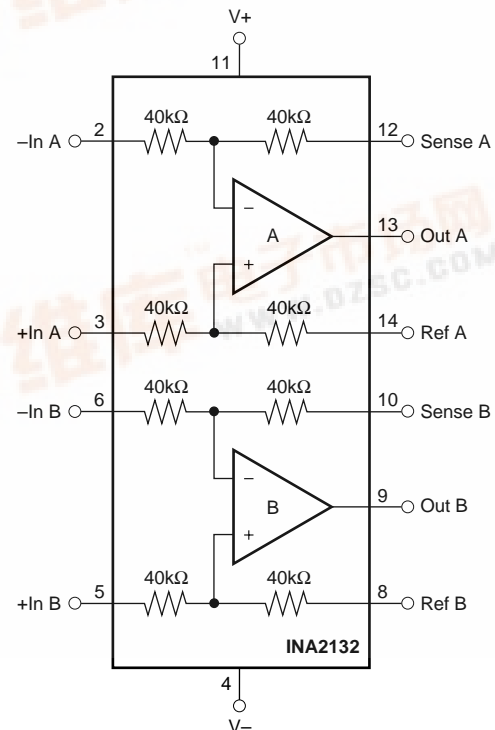

SPECIFICATIONS: $V_S = \pm 15V$

At $T_A = +25^\circ C$, $R_L = 10k\Omega$ connected to ground, and reference pins connected to ground unless otherwise noted.

PARAMETER	CONDITIONS	INA2132U			INA2132UA			UNITS
		MIN	TYP	MAX	MIN	TYP	MAX	
OFFSET VOLTAGE⁽¹⁾	RTO							
Initial V_{OS}			± 75	± 250		*	± 500	μV
vs Temperature dV_{OS}/dT			± 1	± 5		*	± 10	$\mu V/^\circ C$
vs Power Supply PSRR	$V_S = \pm 1.35V$ to $\pm 18V$		± 5	± 30		*	*	$\mu V/V$
vs Time			0.3			*		$\mu V/mo$
Channel Separation ⁽²⁾	dc		0.04			*		$\mu V/V$
INPUT IMPEDANCE⁽³⁾								
Differential			80			*		k Ω
Common-Mode			40			*		k Ω
INPUT VOLTAGE RANGE								
Common-Mode Voltage Range ⁽⁴⁾	$V_O = 0V$	2 (V-)		2 (V+) -2	*		*	V
Common-Mode Rejection Ratio CMRR	$V_{CM} = -30V$ to $28V$, $R_S = 0\Omega$	80	90		74	*		dB
OUTPUT VOLTAGE NOISE⁽⁵⁾	RTO							
f = 0.1Hz to 10Hz			1.6			*		$\mu Vp-p$
f = 1kHz			65			*		nV/\sqrt{Hz}
GAIN								
Initial			1			*		V/V
Error	$V_O = -14V$ to $13.5V$		± 0.01	± 0.05		*	± 0.1	%
vs Temperature			± 1	± 10		*	*	ppm/ $^\circ C$
Nonlinearity	$V_O = -14V$ to $13.5V$		± 0.0001	± 0.001		*	± 0.002	% of FS
OUTPUT								
Voltage, Positive	$R_L = 100k\Omega$ to Ground	(V+) -1	(V+) -0.8		*	*		V
Negative	$R_L = 100k\Omega$ to Ground	(V-) +0.5	(V-) +0.15		*	*		V
Positive	$R_L = 10k\Omega$ to Ground	(V+) -1.5	(V+) -0.8		*	*		V
Negative	$R_L = 10k\Omega$ to Ground	(V-) +1	(V-) +0.25		*	*		V
Current Limit, per Amplifier	Continuous to Common		± 12			*		mA
Capacitive Load (stable operation)			10			*		nF
FREQUENCY RESPONSE								
Small-Signal Bandwidth	-3dB		300			*		kHz
Slew Rate	SR		0.1			*		V/ μs
Settling Time: 0.1%	$V_O = 10V$ Step		85			*		μs
0.01%	$V_O = 10V$ Step		88			*		μs
Overload Recovery Time	50% Overdrive		7			*		μs
POWER SUPPLY								
Rated Voltage	V_S		± 15			*		V
Voltage Range		± 1.35		± 18	*		*	V
Quiescent Current (per amplifier) I_Q	$I_O = 0mA$		± 160	± 185		*	*	μA
TEMPERATURE RANGE								
Specification		-40		+85	*		*	$^\circ C$
Operation		-55		+125	*		*	$^\circ C$
Storage		-55		+125	*		*	$^\circ C$
Thermal Resistance θ_{JA}			100			*		$^\circ C/W$

* Specifications the same as INA2132U.

NOTES: (1) Includes effects of amplifier's input bias and offset currents. (2) Measured output offset change of one channel for a full-scale swing ($V_O = -14V$ to $13.5V$) on the opposite channel. (3) $40k\Omega$ resistors are ratio matched but have $\pm 20\%$ absolute value. (4) $2 (V-) -V_{REF} < V_{CM} < 2 ((V+) -1) -V_{REF}$. For more detail, see Applications Information section. (5) Includes effects of amplifier's input current noise and thermal noise contribution of resistor network.

The information provided herein is believed to be reliable; however, BURR-BROWN assumes no responsibility for inaccuracies or omissions. BURR-BROWN assumes no responsibility for the use of this information, and all use of such information shall be entirely at the user's own risk. Prices and specifications are subject to change without notice. No patent rights or licenses to any of the circuits described herein are implied or granted to any third party. BURR-BROWN does not authorize or warrant any BURR-BROWN product for use in life support devices and/or systems.

SPECIFICATIONS: $V_S = +5V$ Single Supply

At $T_A = +25^\circ\text{C}$, $R_L = 10\text{k}\Omega$ connected to $V_S/2$, and reference pin connected to $V_S/2$, unless otherwise noted.

PARAMETER	CONDITIONS	INA2132U			INA2132UA			UNITS
		MIN	TYP	MAX	MIN	TYP	MAX	
OFFSET VOLTAGE⁽¹⁾	RTO							
Initial V_{OS}			± 150	± 500		*	± 750	μV
vs Temperature dV_{OS}/dT			± 2			*		$\mu\text{V}/^\circ\text{C}$
INPUT VOLTAGE RANGE								
Common-Mode Voltage Range ⁽²⁾		-2.5		+5.5	*		*	V
Common-Mode Rejection CMRR	$V_{CM} = -2.5\text{V to } +5.5\text{V}$, $R_S = 0\Omega$	80	90		74	*		dB
OUTPUT								
Voltage, Positive	$R_L = 100\text{k}\Omega$ to Ground	(V+) -1	(V+) -0.75		*	*		V
Negative	$R_L = 100\text{k}\Omega$ to Ground	+0.25	+0.06		*	*		V
Positive	$R_L = 10\text{k}\Omega$ to Ground	(V+) -1	(V+) -0.8		*	*		V
Negative	$R_L = 10\text{k}\Omega$ to Ground	+0.25	+0.12		*	*		V
POWER SUPPLY								
Rated Voltage V_S			+5			*		V
Voltage Range		+2.7		+36	*		*	V
Quiescent Current I_Q	$I_Q = 0\text{mA}$		± 155	± 185		*	*	μA

* Specifications the same as INA2132U.

NOTE: (1) Includes effects of amplifier's input bias and offset currents. (2) $2(V-) - V_{REF} < V_{CM} < 2((V+) - 1) - V_{REF}$. For more detail, see Applications Information section.

PIN CONFIGURATION

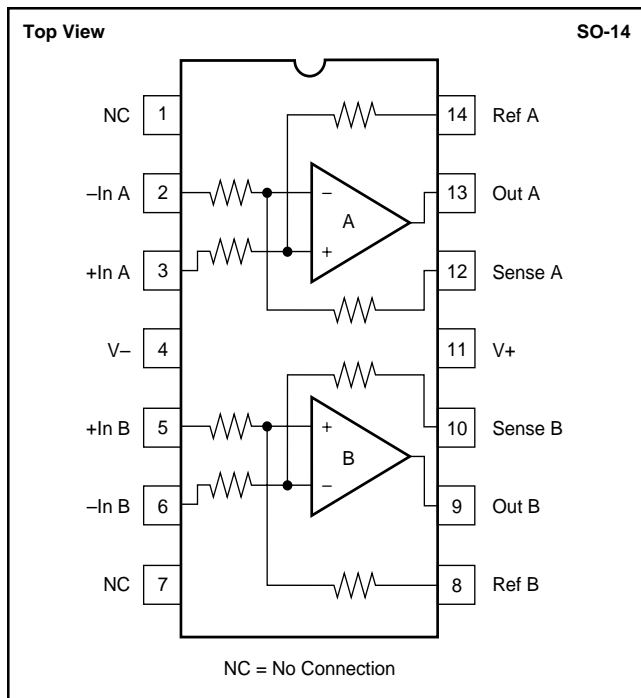

ABSOLUTE MAXIMUM RATINGS

Supply Voltage, $V+$ to $V-$	36V
Input Voltage Range	$\pm 80\text{V}$
Output Short-Circuit (to ground)	Continuous
Operating Temperature	$-55^\circ\text{C to } +125^\circ\text{C}$
Storage Temperature	$-55^\circ\text{C to } +125^\circ\text{C}$
Junction Temperature	$+150^\circ\text{C}$
Lead Temperature (soldering, 10s)	$+300^\circ\text{C}$



ELECTROSTATIC DISCHARGE SENSITIVITY

This integrated circuit can be damaged by ESD. Burr-Brown recommends that all integrated circuits be handled with appropriate precautions. Failure to observe proper handling and installation procedures can cause damage.

ESD damage can range from subtle performance degradation to complete device failure. Precision integrated circuits may be more susceptible to damage because very small parametric changes could cause the device not to meet its published specifications.

PACKAGE/ORDERING INFORMATION

PRODUCT	PACKAGE	PACKAGE DRAWING NUMBER ⁽¹⁾	SPECIFIED TEMPERATURE RANGE	PACKAGE MARKING	ORDERING NUMBER ⁽²⁾	TRANSPORT MEDIA
INA2132U	SO-14 Surface-Mount	235	$-40^\circ\text{C to } +85^\circ\text{C}$	INA2132U	INA2132U	Rails
"	"	"	"	"	INA2132U/2K5	Tape and Reel
INA2132UA	SO-14 Surface-Mount	235	$-40^\circ\text{C to } +85^\circ\text{C}$	INA2132UA	INA2132UA	Rails
"	"	"	"	"	INA2132UA/2K5	Tape and Reel

NOTES: (1) For detailed drawing and dimension table, please see end of data sheet, or Appendix C of Burr-Brown IC Data Book. (2) Models with a slash (/) are available only in Tape and Reel in the quantities indicated (e.g., /2K5 indicates 2500 devices per reel). Ordering 2500 pieces of "INA2132U/2K5" will get a single 2500-piece Tape and Reel. For detailed Tape and Reel mechanical information, refer to Appendix B of Burr-Brown IC Data Book.

TYPICAL PERFORMANCE CURVES

At $T_A = +25^\circ\text{C}$ and $V_S = \pm 15\text{V}$, unless otherwise noted.

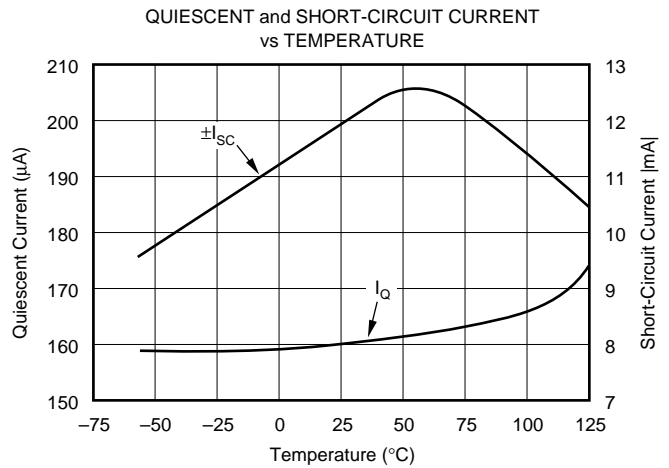
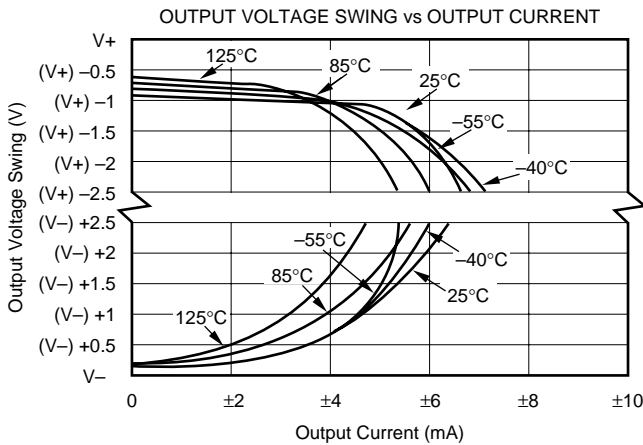
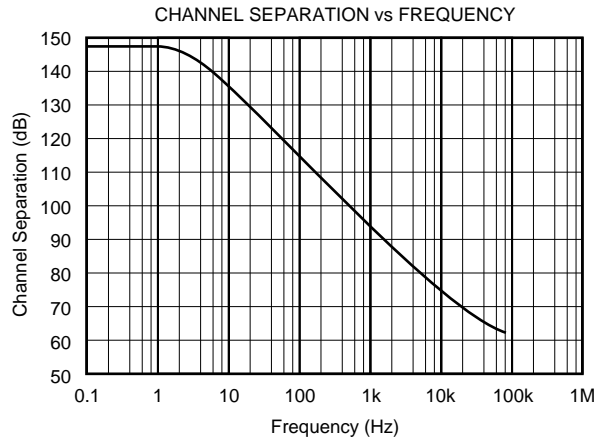
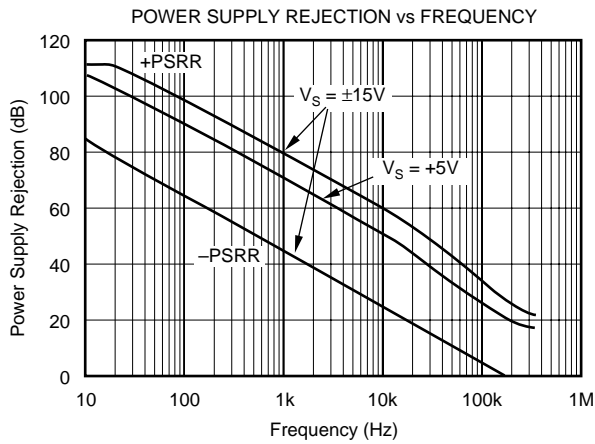
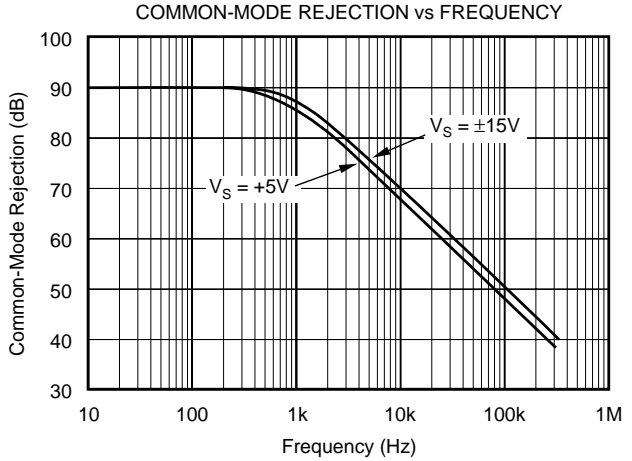
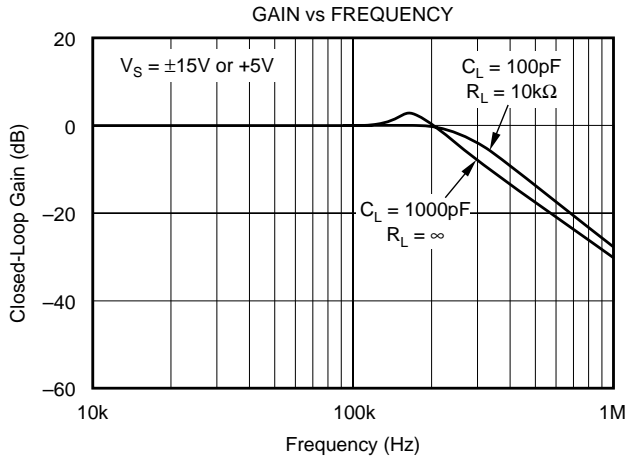

TYPICAL PERFORMANCE CURVES (CONT)

At $T_A = +25^\circ\text{C}$ and $V_S = \pm 15\text{V}$, unless otherwise noted.

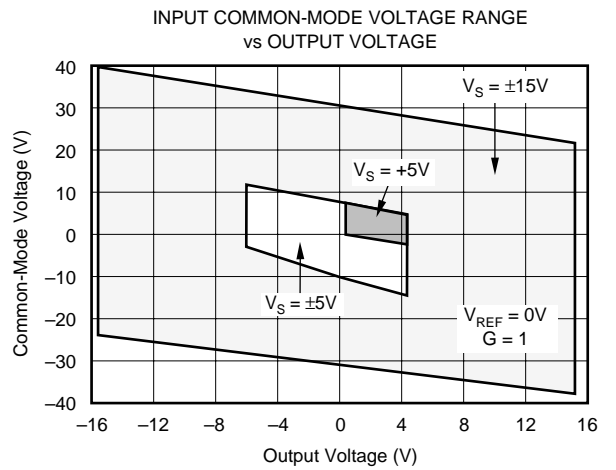
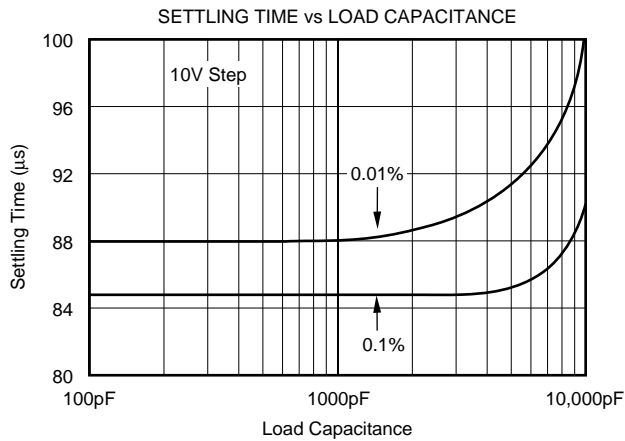
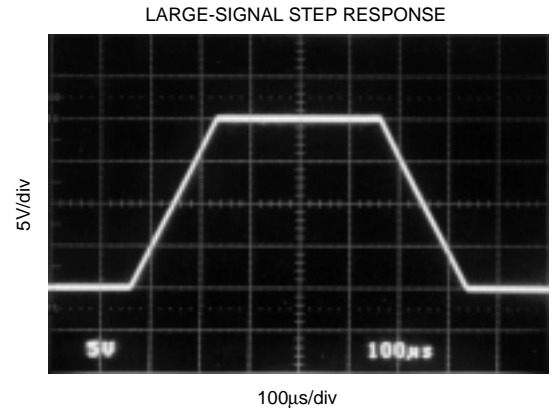
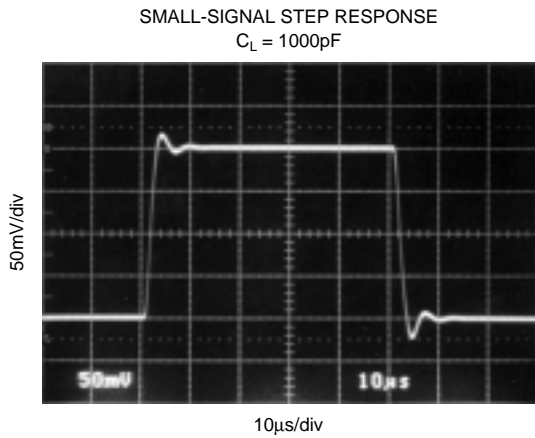
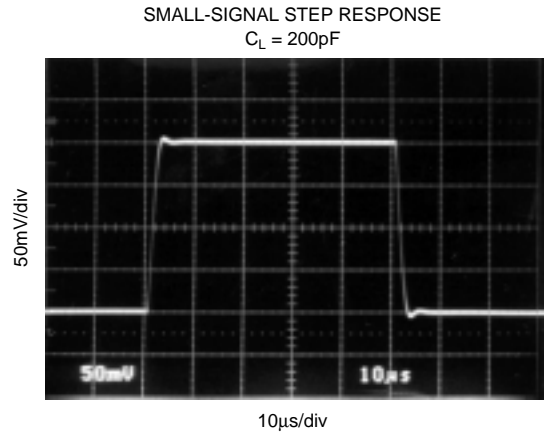
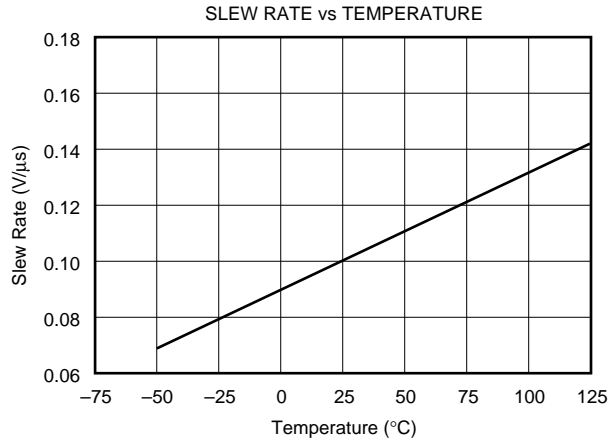

TYPICAL PERFORMANCE CURVES (CONT)

At $T_A = +25^\circ\text{C}$ and $V_S = \pm 15\text{V}$, unless otherwise noted.

0.1Hz to 10Hz PEAK-TO-PEAK
VOLTAGE NOISE

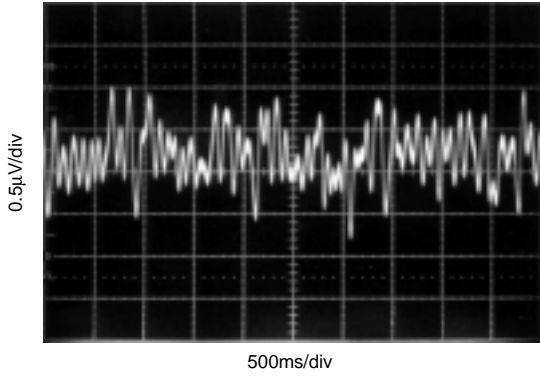

OFFSET VOLTAGE
PRODUCTION DISTRIBUTION

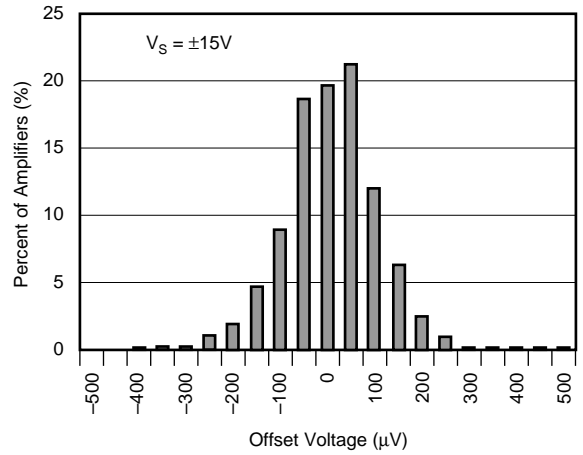

OFFSET VOLTAGE
PRODUCTION DISTRIBUTION

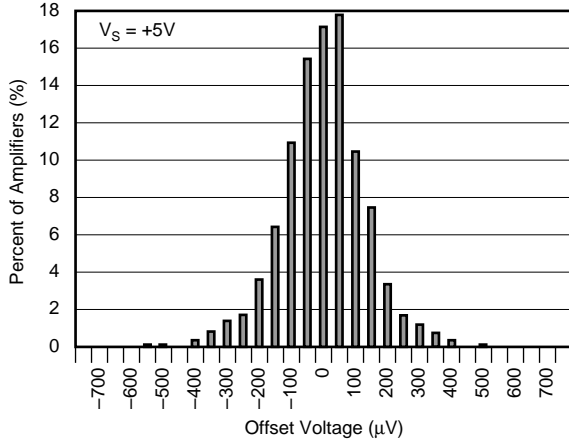

OFFSET VOLTAGE DRIFT
PRODUCTION DISTRIBUTION

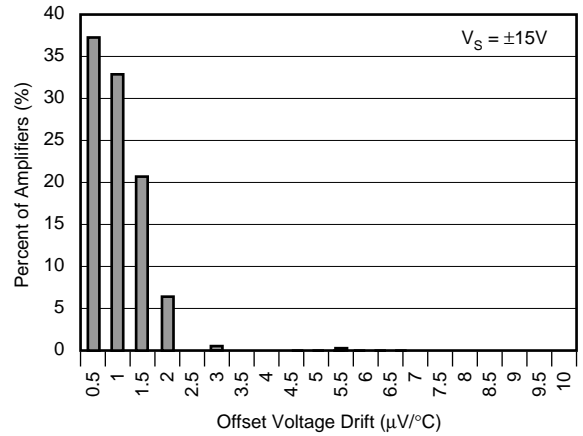

APPLICATIONS INFORMATION

Figure 1 shows the basic connections required for operation of the INA2132. Power supply bypass capacitors should be connected close to the device pins.

The differential input signal is connected to pins 2 and 3 (or pins 6 and 5) as shown. The source impedances connected to the inputs must be nearly equal to assure good common-mode rejection. An 8Ω mismatch in source impedance will degrade the common-mode rejection of a typical device to approximately 80dB. Gain accuracy will also be slightly affected. If the source has a known impedance mismatch, an additional resistor in series with one input can be used to preserve good common-mode rejection.

Do not interchange pins 3 and 14 (or pins 5 and 8) or pins 2 and 12 (or pins 6 and 10), even though nominal resistor values are equal. These resistors are laser-trimmed for precise resistor ratios to achieve accurate gain and highest CMRR. Interchanging these pins may not provide specified performance. As shown in Figure 1, sense line should be connected as close to the load as possible.

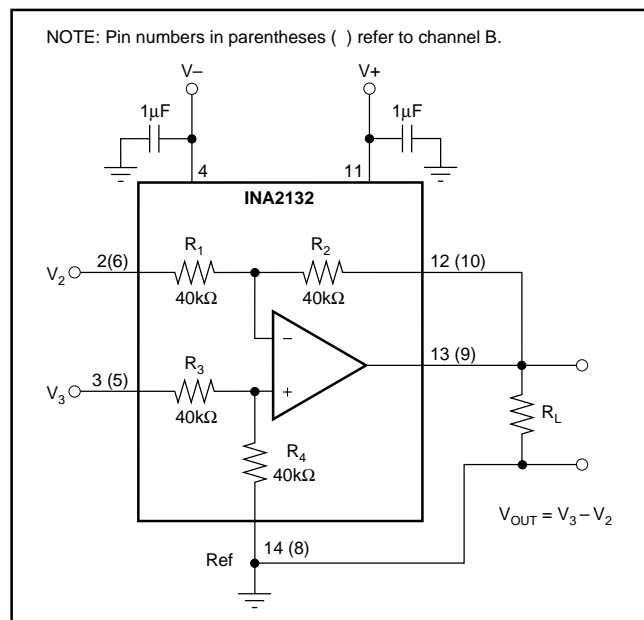

FIGURE 1. Basic Power Supply and Signal Connections.

To ensure valid operation of the differential amplifier, please note the following points:

- 1) $V_{OUT} = V_3 - V_2 + V_{REF}$
- 2) V_{OUT} must be within the specified linear range. For example, with $\pm 15V$ supplies and a $100k\Omega$ load, the output will be defined by:

$$(V-) + 0.15V < V_{OUT} < (V+) - 0.8V$$

- 3) Input common-mode range at the nodes of the op amp must be $V- \leq V_{CM} \leq (V+) - 1$. To ensure that the inputs to the differential amp (+In and -In) meet this criteria, limit the common-mode voltage inputs to:

$$2 \cdot (V-) - V_{REF} < V_{CM} < 2 \cdot ((V+) - 1) - V_{REF}$$

In the case where V_{REF} is grounded, the equation simplifies to:

$$2 \cdot (V-) < V_{CM} < 2 \cdot ((V+) - 1)$$

For more information, see the typical performance curve titled “Input Common-Mode Voltage Range vs Output Voltage.”

OPERATING VOLTAGE

The INA2132 operates from single ($+2.7V$ to $+36V$) or dual ($\pm 1.35V$ to $\pm 18V$) supplies with excellent performance. Specifications are production tested with $+5V$ and $\pm 15V$ supplies. Most behavior remains unchanged throughout the full operating voltage range. Parameters which vary significantly with operating voltage are shown in the Typical Performance Curves.

The INA2132 can accurately measure differential signals that are beyond the power supply rails. Linear common-mode range extends to twice the negative power supply voltage and nearly twice the positive power supply voltage. Output phase reversal does not occur when the inputs to the internal operational amplifier are overloaded to either rail. See typical performance curve, “Common-Mode Range vs Output Voltage.”

OFFSET VOLTAGE TRIM

The INA2132 is laser-trimmed for low offset voltage and drift. Most applications require no external offset adjustment. Figure 2 shows an optional circuit for trimming the output offset voltage. The output is referred to the output reference terminal (pin 14 or pin 8), which is normally grounded. A voltage applied to the Ref terminal will be summed with the output signal. This can be used to null offset voltage. The source impedance of a signal applied to the Ref terminal should be less than 8Ω to maintain good common-mode rejection. To assure low impedance at the Ref terminal, the trim voltage can be buffered with an op amp, such as the OPA277.

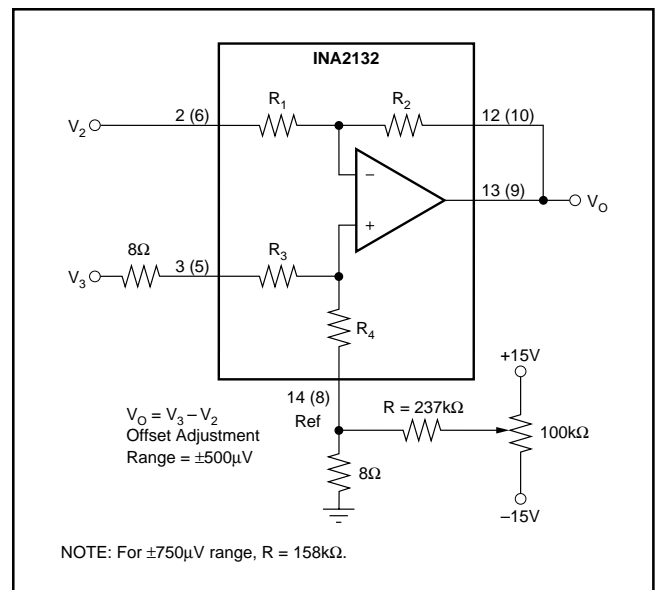

FIGURE 2. Offset Adjustment.

CAPACITIVE LOAD DRIVE CAPABILITY

The INA2132 can drive large capacitive loads, even at low supplies. It is stable with a 10nF load. Refer to the “Small-Signal Step Response” and “Settling Time vs Load Capacitance” typical performance curves.

CHANNEL CROSSTALK

The two channels of the INA2132 are completely independent, including all bias circuitry. At dc and low frequency, there is virtually no signal coupling between channels. Crosstalk increases with frequency and is dependent on source impedance and signal characteristics. See the typical performance curve “Channel Separation vs Frequency” for more information.

Most crosstalk is produced by capacitive coupling of signals from one channel to the input section of the other channel. To minimize coupling, separate the input traces as far as practical from any signals associated with the opposite channel. A grounded guard trace surrounding the inputs helps reduce stray coupling between channels. Run the differential inputs of each channel parallel to each other or

directly adjacent on the top and bottom sides of a circuit board. Stray coupling then produces a common-mode signal which is rejected by the INA2132’s input.

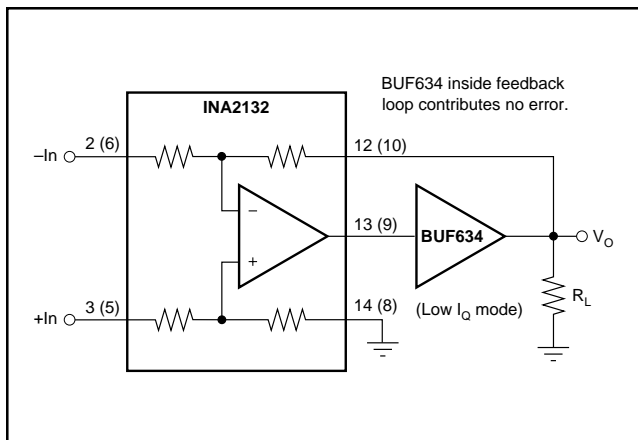

FIGURE 3. Low Power, High Output Current Precision Difference Amplifier.

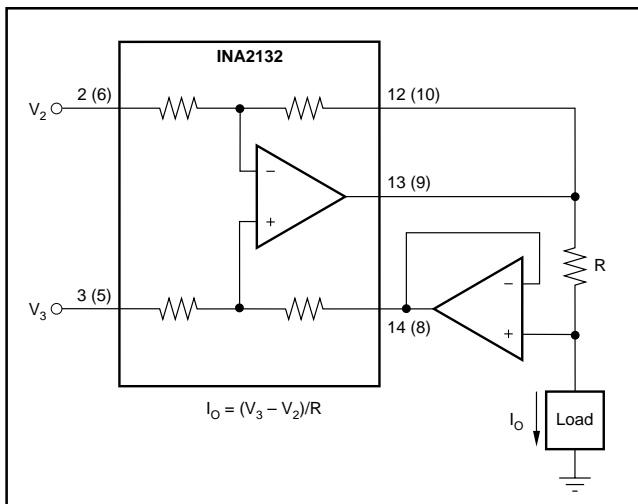

FIGURE 4. Differential Input Voltage-to-Current Converter for Low I_{OUT} .

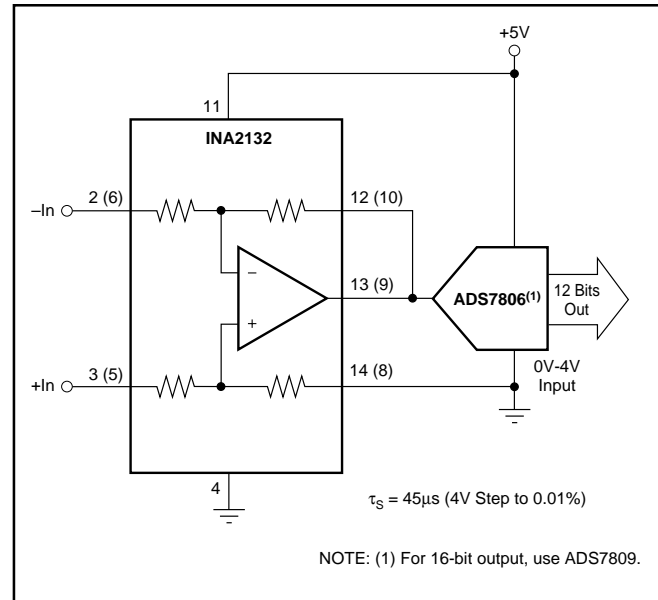

FIGURE 5. Differential Input Data Acquisition.

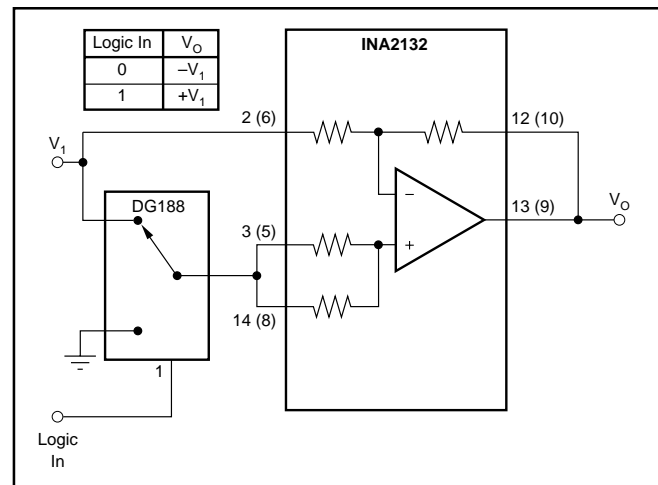

FIGURE 6. Digitally Controlled Gain of ± 1 Amplifier.

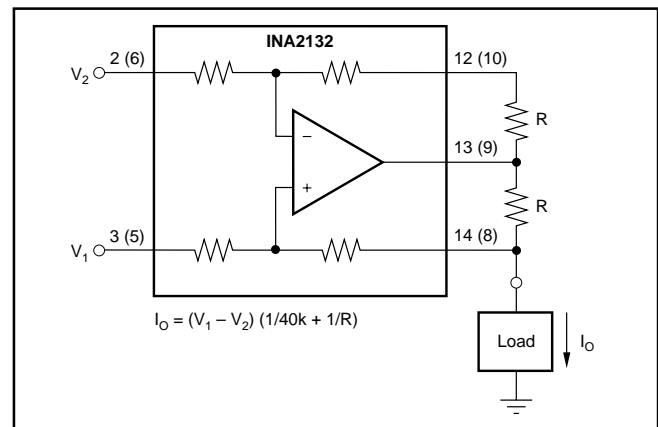

FIGURE 7. Precision Voltage-to-Current Converter with Differential Inputs.

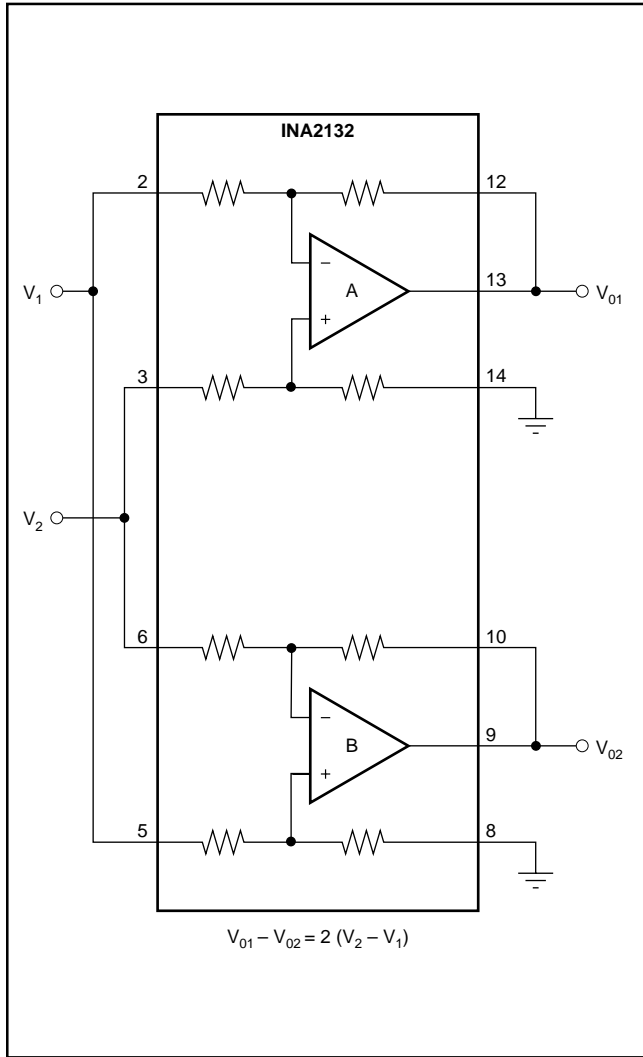

FIGURE 8. Differential Output Difference Amplifier.

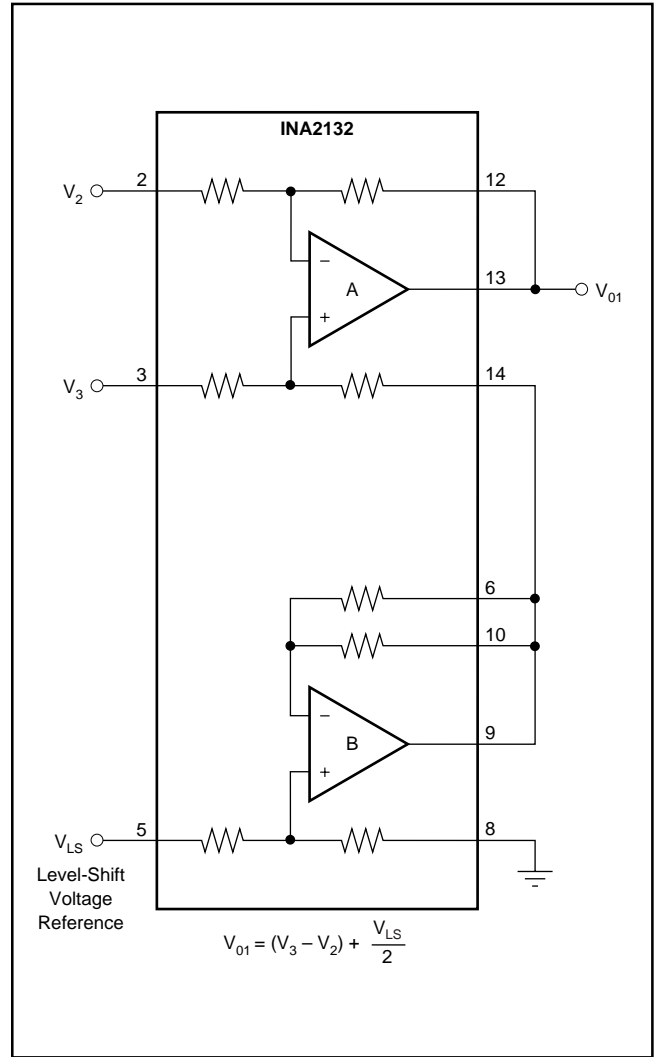

FIGURE 9. Precision Level Shifter.

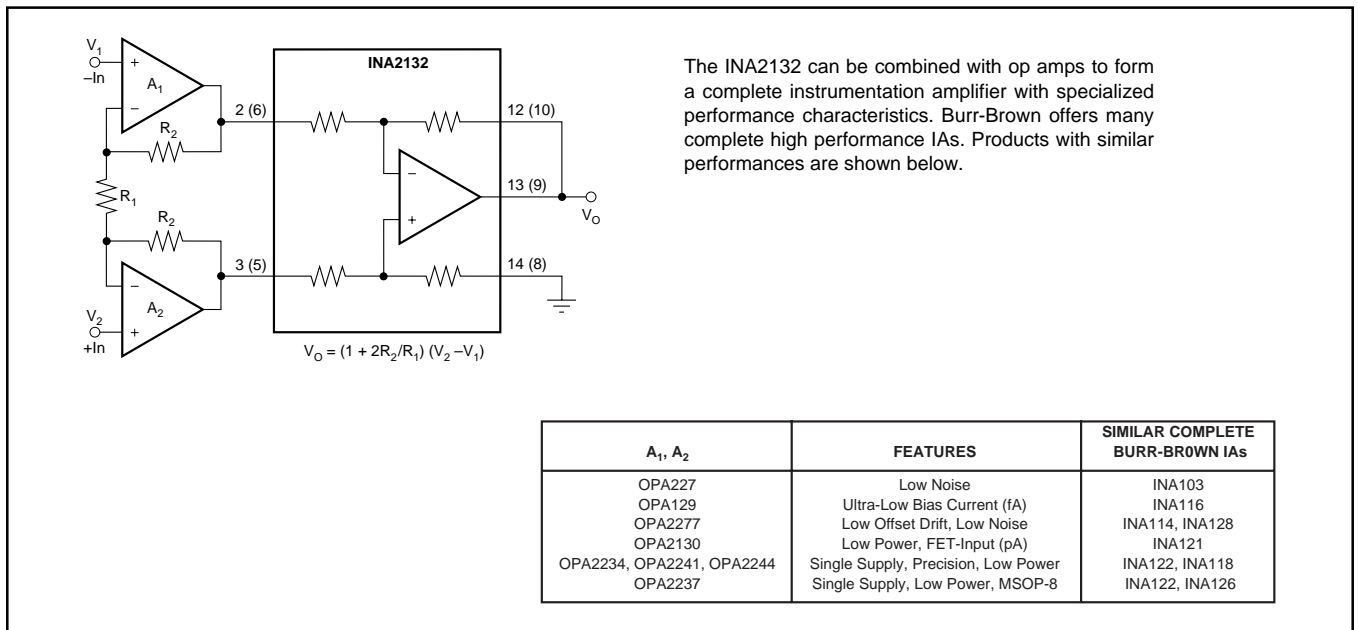

FIGURE 10. Precision Instrumentation Amplifier.

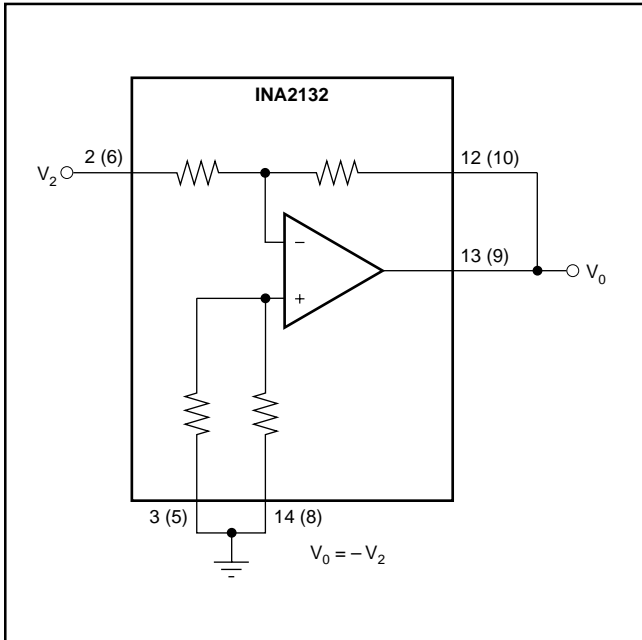

FIGURE 11. Precision Inverting Unity-Gain Amplifier.

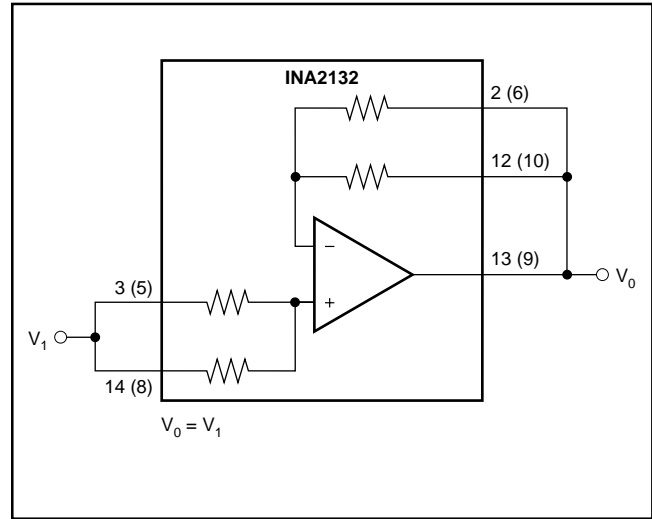

FIGURE 14. Precision Unity-Gain Buffer.

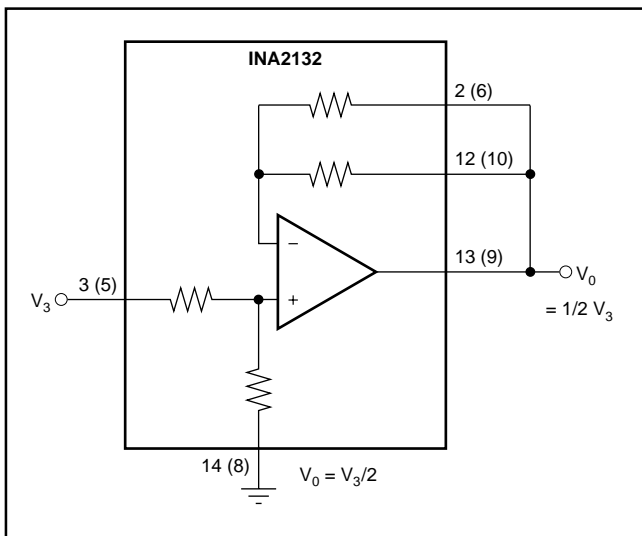

FIGURE 12. Precision Gain = 1/2 Amplifier.

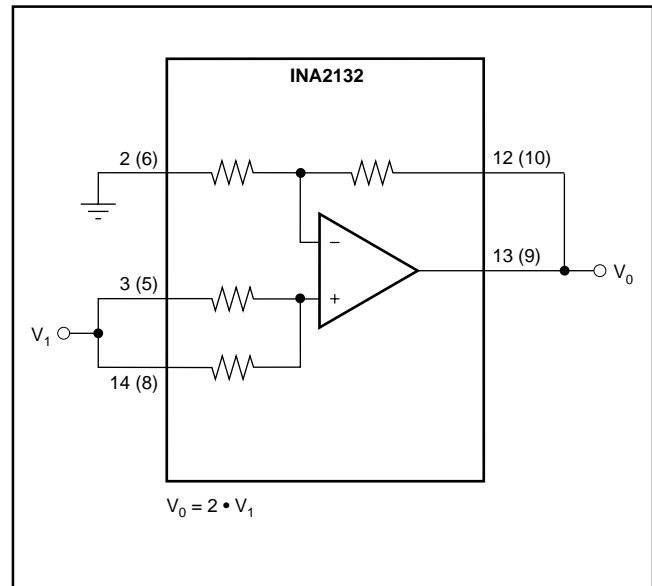

FIGURE 15. Precision Gain = 2 Amplifier.

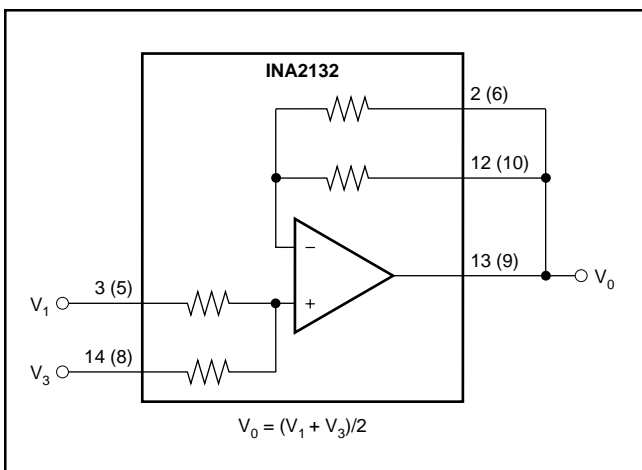

FIGURE 13. Precision Average Value Amplifier.

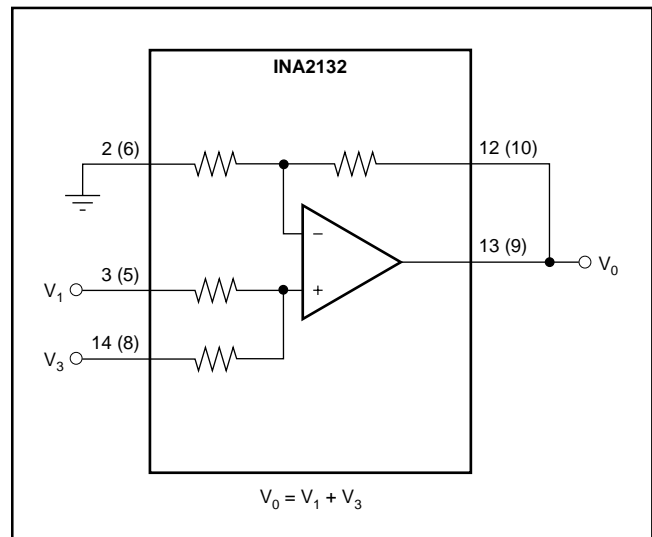

FIGURE 16. Precision Summing Amplifier.