

INA3010

INA3010

INFRARED REMOTE CONTROL TRANSMITTER RC-5

The INA3010 is intended as a general purpose (RC-5) infrared remote control system for use where a low voltage supply and a large debounce time are expected. The device can generate 2048 different commands and utilizes a keyboard with a single pole switch for each key. The command are arranged so that 32 systems can be addressed, each system containing 64 different commands. The keyboard interconnection is illustrated by Fig.1.

- Low voltage requirement
- Single pin oscillator
- Biphase transmission technique
- Test mode facility



ORDERING INFORMATION
 INA3010N Plastic
 INA3010DW SOIC
 $T_A = -25^\circ \text{ to } 85^\circ \text{ C}$
 for all packages.

BLOCK DIAGRAM

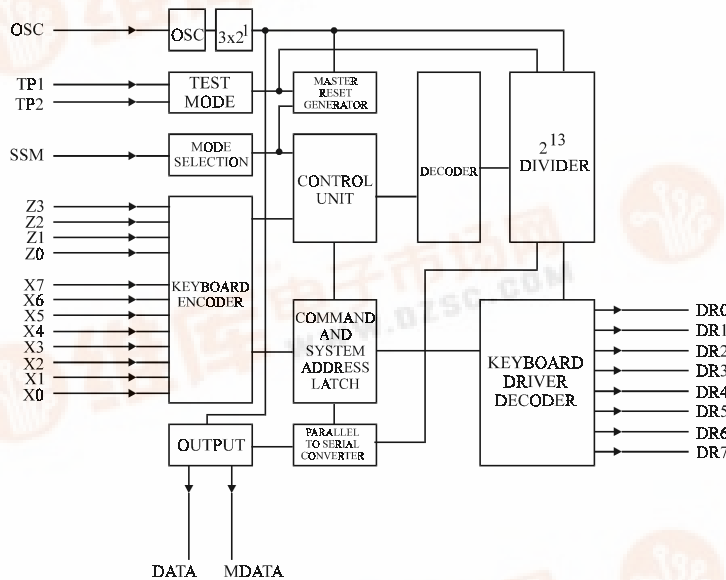

PIN ASSIGNMENT

X7	1 ●	28	V _{CC}
SSM	2	27	X6
Z0	3	26	X5
Z1	4	25	X4
Z2	5	24	X3
Z3	6	23	X2
MDATA	7	22	X1
DATA	8	21	X0
DR7	9	20	TP1
DR6	10	19	TP2
DR5	11	18	OSC
DR4	12	17	DR0
DR3	13	16	DR1
GND	14	15	DR2

INA3010

PIN DESCRIPTION

PIN No	DESIGNATION	DESCRIPTION
1	X7 (IPU)	sense input from key matrix
2	SSM (I)	system mode selection input
3-6	Z0-Z3 (IPU)	sense inputs from key matrix
7	MDATA (OP3)	generated output data modulated with 1/2 the oscillator frequency at a 25% duty factor
8	DATA (OP3)	generated output information
9-13	DR7-DR3 (ODN)	scan drivers
14	GND	ground (0V)
15-17	DR2-DR0 (ODN)	scan drivers
18	OSC (I)	oscillator input
19	TP2 (I)	test point 2
20	TP1 (I)	test point 1
21-27	X0-X6 (IPU)	sense inputs from key matrix
28	Vcc (I)	voltage supply

(I) = input

(IPU) = input with p-channel pull-up transistor

(ODN) = output with open drain n-channel transistor

(OP3) = output 3-state

FUNCTIONAL DESCRIPTION

Keyboard operation

Every connection of one X-input and one DR-output will be recognized as a legal key operation and will cause the device to generate the corresponding code. The same applies to every connection of one Z-input to one DR-output with the proviso that SSM must be LOW. When SSM is HIGH a wired connection must exist between a Z-input and DR-output. If no connection is present the system number will not be generated. Activating two or more X-inputs, Z-inputs or Z-inputs and X-inputs at the same time is an illegal action and inhibits further activity (oscillator will not start).

When one X- or Z-input is connected to more than one DR-output, the last scan signal will be considered as legal.

The maximum value of the contact series resistance of the switched keyboard is 7K Ω .

Inputs

In the quiescent state the command inputs X0 to X7 are held HIGH by an internal pull-up transistor. When the system mode selection (SSM) input is LOW and the system is quiescent, the system inputs Z0 to Z3 are also held HIGH by an internal pull-up transistor. When SSM is HIGH the pull-up transistor for the Z-inputs is switched off, in order to prevent current flow, and a wired connection in the Z-DR matrix provides the system number.

Outputs

The output signal DATA transmits the generated information in accordance with the format illustrated by Fig.2 and Tables 1 and 2. The code is transmitted using a biphasic technique as illustrated by Fig.3. The code consists of four parts:

- Start part - 1.5 bits (2 x logic 1)
- Control part - 1 bit
- System part - 5 bits
- Command part - 6 bits

The output signal MDATA transmits the generated information modulated by 1/12 of the oscillator frequency with a 50% duty factor.

In the quiescent state both DATA and MDATA are non-conducting (3-state outputs).

The scan driver outputs DR0 to DR7 are open drain n-channel transistors and conduct when the circuit is quiescent. After a legal key operation the scanning cycle is started and the outputs switched to the conductive state one by one. The DR-outputs were switched off at the end of the preceding debounce cycle.

Table 1 Command matrix (X-DR)

Code no.	X-lines							DR-lines							Command bits							
	0	1	2	3	4	5	6	7	0	1	2	3	4	5	6	7	5	4	3	2	1	0
0	x								x								0	0	0	0	0	0
1	x									x							0	0	0	0	0	1
2	x										x						0	0	0	0	1	0
3	x											x					0	0	0	0	1	1
4	x												x				0	0	0	1	0	0
5	x													x			0	0	0	1	0	1
6	x														x		0	0	0	1	1	0
7	x															x	0	0	0	1	1	1
8		x							x								0	0	1	0	0	0
9		x								x							0	0	1	0	0	1
10		x									x						0	0	1	0	1	0
11		x										x					0	0	1	0	1	1
12		x											x				0	0	1	1	0	0
13		x												x			0	0	1	1	0	1
14		x													x		0	0	1	1	1	0
15		x														x	0	0	1	1	1	1
16			x						x								0	1	0	0	0	0
17			x							x							0	1	0	0	0	1
18			x								x						0	1	0	0	1	0
19			x									x					0	1	0	0	1	1
20			x										x				0	1	0	1	0	0
21			x											x			0	1	0	1	0	1
22			x												x		0	1	0	1	1	0
23			x													x	0	1	0	1	1	1
24				x					x								0	1	1	0	0	0
25				x						x							0	1	1	0	0	1
26				x							x						0	1	1	0	1	0
27				x								x					0	1	1	0	1	1
28				x									x				0	1	1	1	0	0
29				x										x			0	1	1	1	0	1
30				x											x		0	1	1	1	1	0
31				x												x	0	1	1	1	1	1
32					x				x								1	0	0	0	0	0
33					x					x							1	0	0	0	0	1
34					x						x						1	0	0	0	1	0
35					x							x					1	0	0	0	1	1
36					x								x				1	0	0	1	0	0
37					x									x			1	0	0	1	0	1
38					x										x		1	0	0	1	1	0
39					x											x	1	0	0	1	1	1
40						x			x								1	0	1	0	0	0
41						x				x							1	0	1	0	0	1
42						x					x						1	0	1	0	1	0
43						x						x					1	0	1	0	1	1
44						x							x				1	0	1	1	0	0
45						x								x			1	0	1	1	0	1
46						x									x		1	0	1	1	1	0
47						x										x	1	0	1	1	1	1
48							x		x								1	1	0	0	0	0

Table 1 Command matrix (X-DR) (Continued)

INA3010

Code no.	X-lines							DR-lines							Command bits						
	0	1	2	3	4	5	6	7	0	1	2	3	4	5	6	7	5	4	3	2	1
49							x		x							1	1	0	0	0	1
50							x			x						1	1	0	0	1	0
51							x				x					1	1	0	0	1	1
52							x					x				1	1	0	1	0	0
53							x						x			1	1	0	1	0	1
54							x							x		1	1	0	1	1	0
55							x								x	1	1	0	1	1	1
56								x	x							1	1	1	0	0	0
57								x		x						1	1	1	0	0	1
58								x			x					1	1	1	0	1	0
59								x				x				1	1	1	0	1	1
60								x					x			1	1	1	1	0	0
61								x						x		1	1	1	1	0	1
62								x							x	1	1	1	1	1	0
63								x								1	1	1	1	1	1

Table 2 System matrix (Z-DR)

Code no.	X-lines							DR-lines							System bits					
	0	1	2	3	4	5	6	7	0	1	2	3	4	5	6	7	4	3	2	1
0	x								x							0	0	0	0	0
1	x									x						0	0	0	0	1
2	x										x					0	0	0	1	0
3	x											x				0	0	0	1	1
4	x												x			0	0	1	0	0
5	x													x		0	0	1	0	1
6	x														x	0	0	1	1	0
7	x															x	0	0	1	1
8		x							x							0	1	0	0	0
9		x								x						0	1	0	0	1
10		x									x					0	1	0	1	0
11		x										x				0	1	0	1	1
12		x											x			0	1	1	0	0
13		x												x		0	1	1	0	1
14		x													x	0	1	1	1	0
15		x														x	0	1	1	1
16			x						x							1	0	0	0	0
17			x							x						1	0	0	0	1
18			x								x					1	0	0	1	0
19			x									x				1	0	0	1	1
20			x										x			1	0	1	0	0
21			x											x		1	0	1	0	1
22			x												x	1	0	1	1	0
23			x													x	1	0	1	1
24				x					x							1	1	0	0	0
25				x						x						1	1	0	0	1
26				x							x					1	1	0	1	0
27				x								x				1	1	0	1	1
28				x									x			1	1	1	0	0
29				x										x		1	1	1	0	1
30				x											x	1	1	1	1	0
31				x												x	1	1	1	1

MAXIMUM RATINGS*

Symbol	Parameter	Value	Unit
V _{CC}	DC Supply Voltage (Referenced to GND)	-0.5 to +8.5	V
V _{IN}	DC Input Voltage (Referenced to GND)*	-0.5 to V _{CC} +0.5	V
V _{OUT}	DC Output Voltage (Referenced to GND)*	-0.5 to V _{CC} +0.5	V
I _{IN}	DC Input Current	±10	mA
I _{OUT}	DC Output Current	±10	mA
P _{DO}	Maximum Power Dissipation		
	OSC output	50	mW
P _{DO}	other outputs	100	mW
P _D	Power Dissipation in Still Air	200	mW
T _{stg}	Storage Temperature	-65 to +150	°C

*V_{CC} + 0.5 must not exceed 9.0V..

*Maximum Ratings are those values beyond which damage to the device may occur. Functional operation should be restricted to the Recommended Operating Conditions.

+Derating - Plastic DIP: - 10 mW/°C from 65° to 85°C

SOIC Package: : - 7 mW/°C from 65° to 85°C

RECOMMENDED OPERATING CONDITIONS

Symbol	Parameter	Min	Max	Unit	
V _{CC}	DC Supply voltage (Reference to GND)	2.0	7.0	V	
V _{IH}	DC Input voltage (HIGH)	0.7V _{CC}	V _{CC}	V	
V _{IL}	DC Input voltage (LOW)	0	0.3V _{CC}	V	
V _{OUT}	DC Output Voltage (MDATA, DATA)	-	7.0	V	
I _{IN}	DC Input Current	-	±10	mA	
I _{OL}	DC Output Current (LOW)	-	pins 7,8	0.6	mA
			pins 9-13; 15-17	0.3	
I _{OH}	DC Output Current (MDATA, DATA)	-	-0.4	mA	
T _A	Operating Temperature, All Package Types	-25	85	°C	

This device contains protection circuitry to guard against damage due to high static voltages or electric fields. However, precautions must be taken to avoid applications of any voltage higher than maximum rated voltages to this high-impedance circuit. For proper operation, V_{IN} and V_{OUT} should be constrained to the range GND ≤ (V_{IN} or V_{OUT}) ≤ V_{CC}.

Unused inputs must always be tied to an appropriate logic voltage level (e.g., either GND or V_{CC}). Unused outputs must be left open.

INA3010

DC ELECTRICAL CHARACTERISTICS (Voltage Reference to GND)

($V_{CC}= 2.0$ to $7.0V$ unless otherwise specified, $T_A=-25$ to $+70^{\circ}C$)

Symbol	Parameter	Test Conditions	Guaranteed Limits		Unit
			Min	Max	
I_{CC}	Quiescent supply current	$U_{IL}=0B$; $V_{IH}=V_{CC}$ $I_{OUT}=0$ mA at all outputs		40	μA
INPUTS					
I_{IN}	Input current Pins 01, 03-06; 21-27	$V_{IL}=0V$	-10	-600	μA
	Pin 18	$V_{IL}=0V$; $V_{IH}=V_{CC}$	3.0	33	
I_{LI}	Input leakage current Pins 01-06;19-27	$V_{IL}=0V$; $V_{IH}=V_{CC}$	-	± 10	μA
	Pin 18		-	-20	
OUTPUTS					
V_{OH}	Output voltage HIGH, pins 07-08	$I_{OH}=-0.4mA$ $V_{IL}=0.3 V_{CC}$	$V_{CC}-0.3$	-	V
V_{OL}	Output voltage LOW Pins 07-08	$I_{OL}=0.6mA$ $V_{IL}=0V$, $V_{IH}=0.7V_{CC}$	-	0.3	V
	Pins 9-13; 15-17	$I_{OL}=0.3mA$, $V_{IL}=0V$, $V_{IH}=0.7V_{CC}$	-	0.3	V
I_{LO}	Output leakage current Pins 07-13; 15-17	$V_O=V_{CC}$, $V_{IH}=V_{CC}$, $V_{OH}=V_{CC}$	-	10	μA
			-		
I_{LO}	Output leakage current Pins 07-08	$V_O=0V$, $V_{IH}=V_{CC}$, $V_{OL}=0V$	-	-20	μA
			-		
I_{OH}	DC Output Current Pins 9-13; 15-17	$V_{IL}=0V$; $V_{IH}=V_{CC}$; $V_{OH}=V_{CC}$		10	μA

AC ELECTRICAL CHARACTERISTICS

$T_A=-25$ to $+85^{\circ}C$; $V_{CC}=2.0$ to 7.0 V unless otherwise specified

Symbol	Parameter	Test Condition	Guaranteed Limits		Unit
			Typ	Max	
f_{OSC}	Oscillator frequency operational	$C_L=160pF$	432	450	KHz

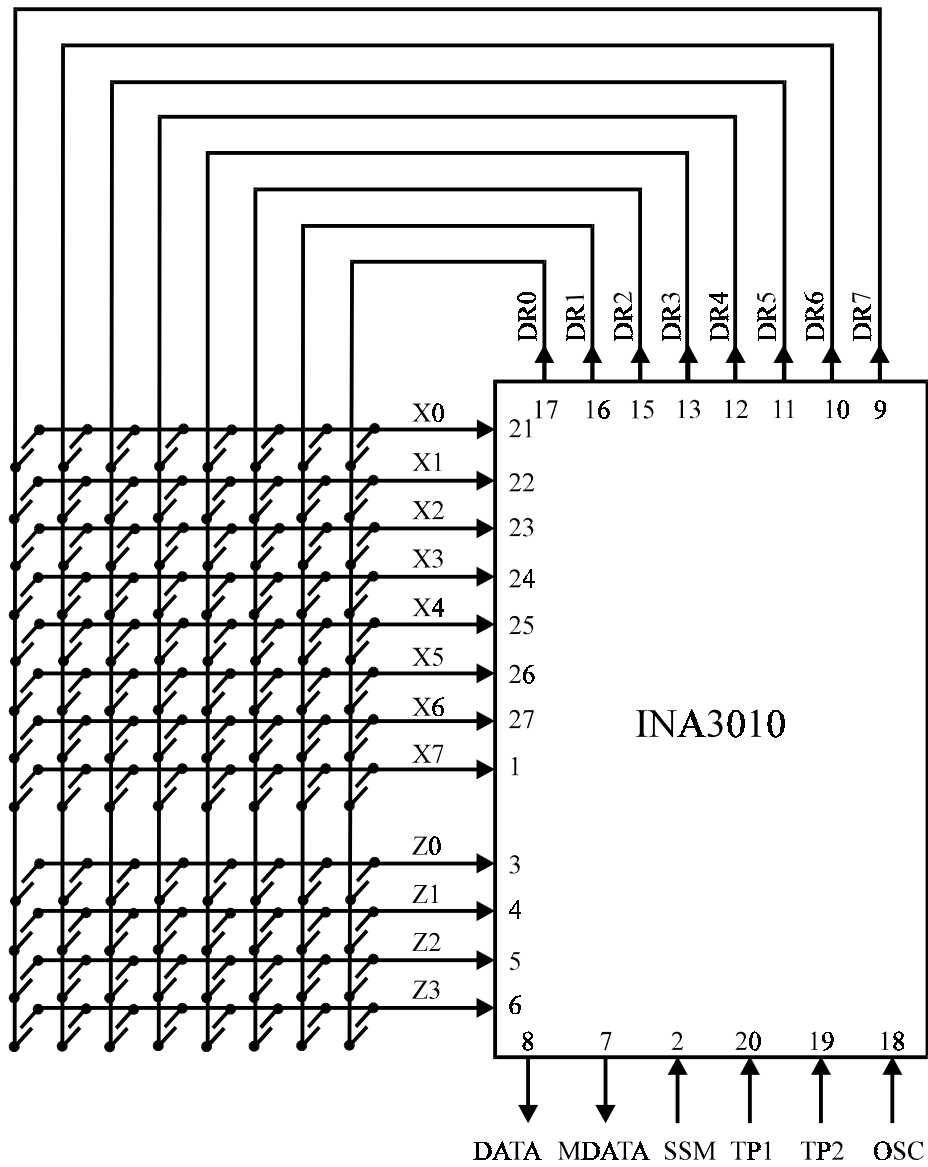
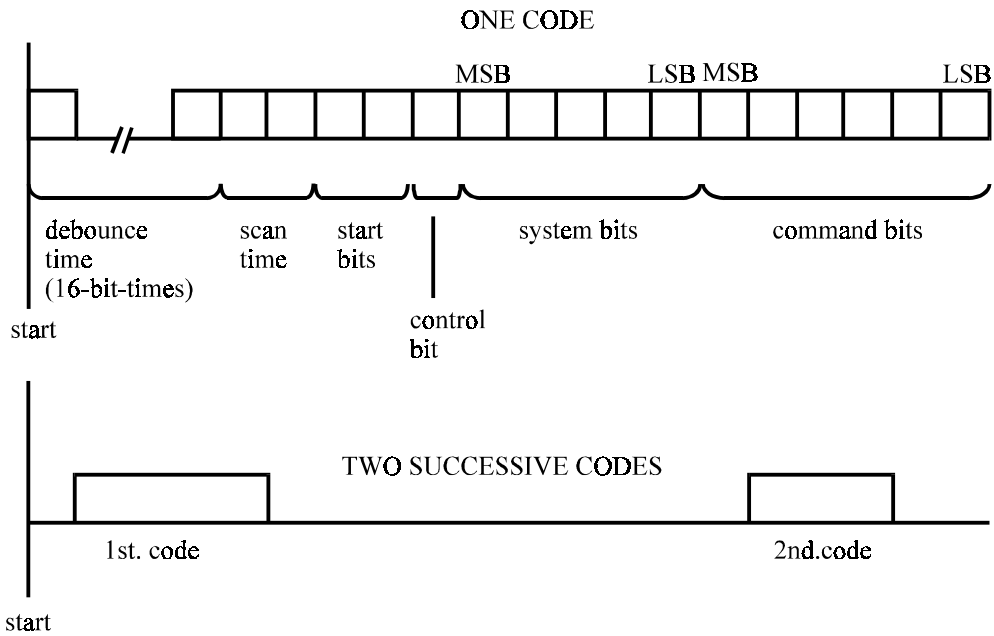
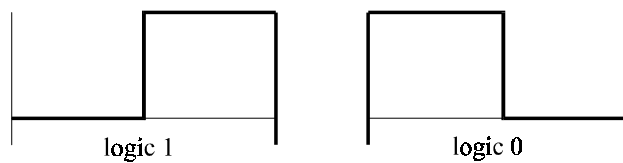

Figure 1. Keyboard interconnection



Where: debounce time+scan time=18 bit-times
 repetition time=4x16 bit times

Figure 2. Data output format



Where: 1 bit-time=3.2⁸ x T_{Osc}=1.778 ms (typ.)

Figure 3. Biphase transmission technique