



***THIS DOCUMENT IS FOR MAINTENANCE
PURPOSES ONLY AND IS NOT
RECOMMENDED FOR NEW DESIGNS***



SP4740

1.3GHz ÷256 PRESCALER WITH LOW CURRENT AND LOW RADIATION

The SP4740 ÷256 prescaler is one of GPS' range of high speed dividers for consumer frequency synthesis and measurement systems. It has a low supply current, giving reduced dissipation and operating temperatures in an 8-pin plastic DIL (DP8) or miniature plastic DIL (MP8) package. Spurious radiation has been reduced from all stages.

The SP4740 incorporates an on-chip preamplifier with differential inputs and has a TTL/CMOS compatible output.

FEATURES

- Low Supply Current
 - Low Radiation
 - Input Wideband Amplifier
 - High Input Sensitivity
 - High Input Impedance
 - TTL/CMOS Output
 - Electrostatic Protection †
- † ESD precautions must be observed

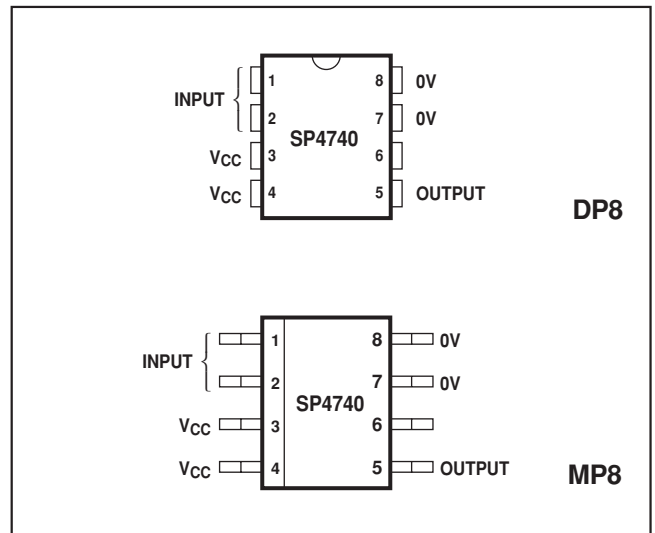

Fig 1. Pin connections - top view

ABSOLUTE MAXIMUM RATINGS

Supply voltage, V_{CC}	+7V
Input voltage	2.5V p-p
Storage temperature	-55°C to +150°C
Operating temperature range	0°C to +80°C

ORDERING INFORMATION

- SP4740 NA DP
- SP4740 NA MP

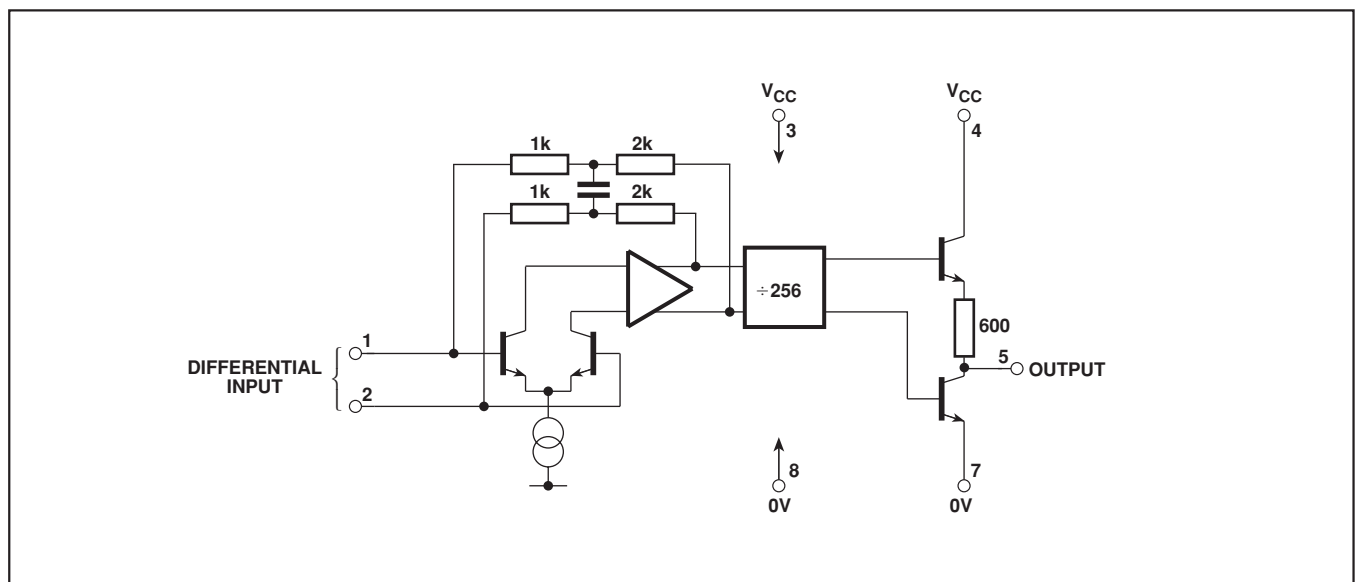

Fig. 2 SP4740 block diagram

SP4740

ELECTRICAL CHARACTERISTICS

These characteristics are guaranteed over the following conditions (unless otherwise stated):

$T_{AMB} = 0^{\circ}\text{C}$ to $+70^{\circ}\text{C}$, $V_{CC} = 4.5\text{V}$ to 5.5V (Test circuit see Fig. 3)

Characteristic	Pin	Value			Units	Conditions
		Min.	Typ.	Max.		
Supply current, I_{CC}	8		35	50	mA	$V_{CC} = +5\text{V}$
Input sensitivity	2,3					RMS sinewave
50MHz			3	5	mV	
150MHz to 1000MHz			1	5	mV	
1.1GHz			1.5		mV	
1.2GHz			2		mV	
1.3GHz			4		mV	
Input overload	2,3	300			mV	50MHz to 500MHz
		400			mV	500MHz to 1.3GHz
Input impedance	2,3		50		Ω	See Fig. 6
			2		pF	
Output voltage						
High	5	3.3			V	Sourcing 0.2mA
Low	5			0.1	V	Sinking 2mA

NOTE

The difference between the maximum input sensitivity and minimum overload voltage is the guaranteed dynamic range. Input signal levels should be maintained within these limits at all frequencies.

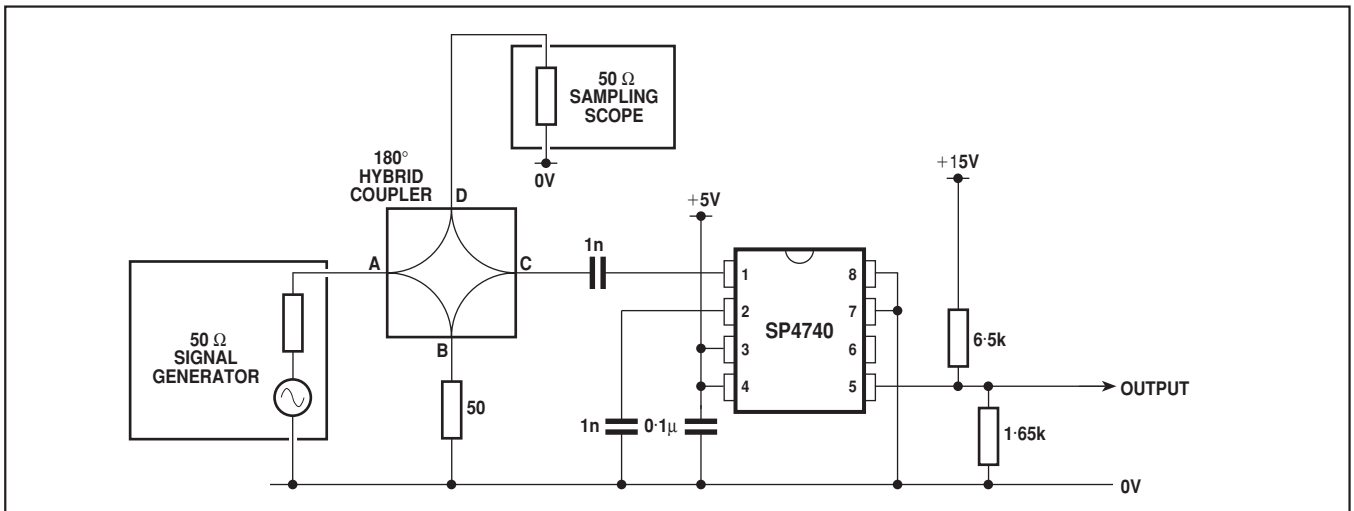

Fig. 3 Test circuit

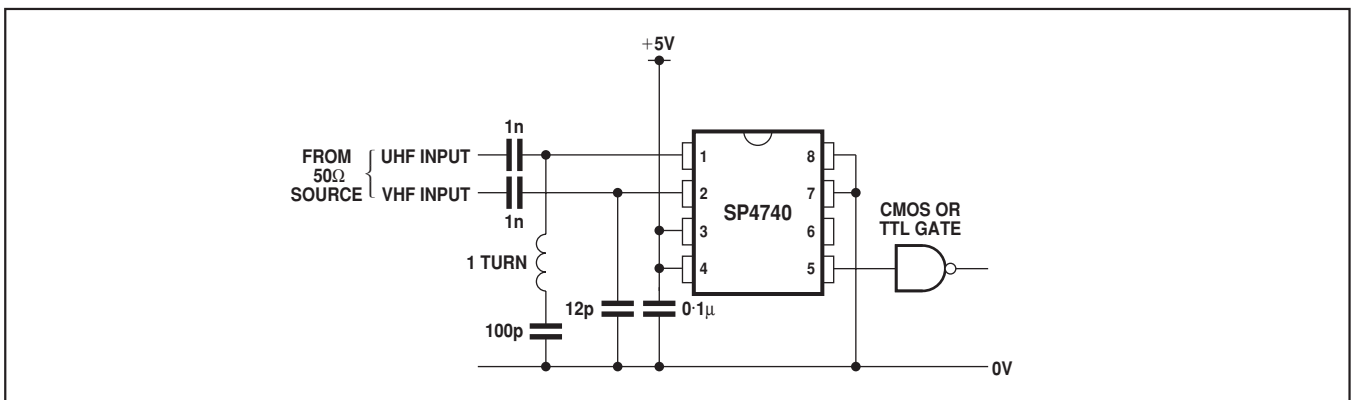

Fig. 4 Application circuit

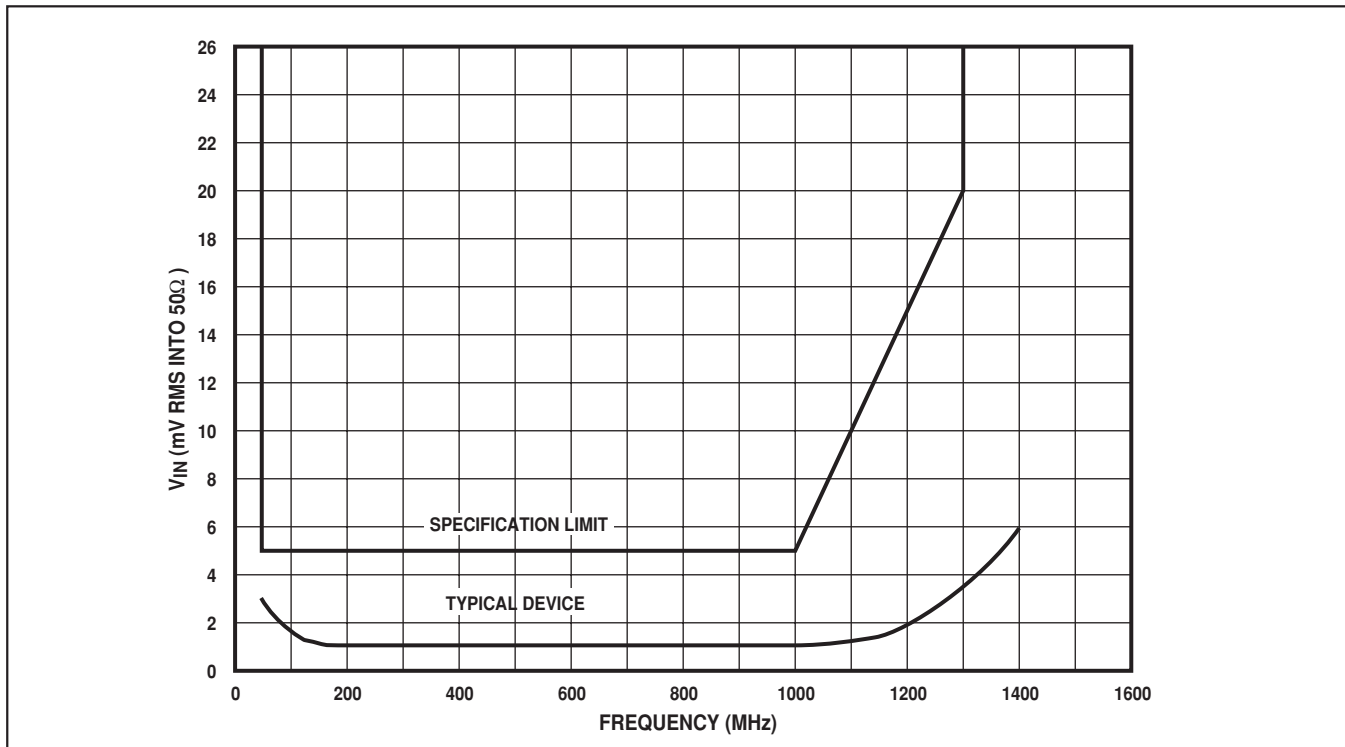

Fig. 5 Typical input sensitivity

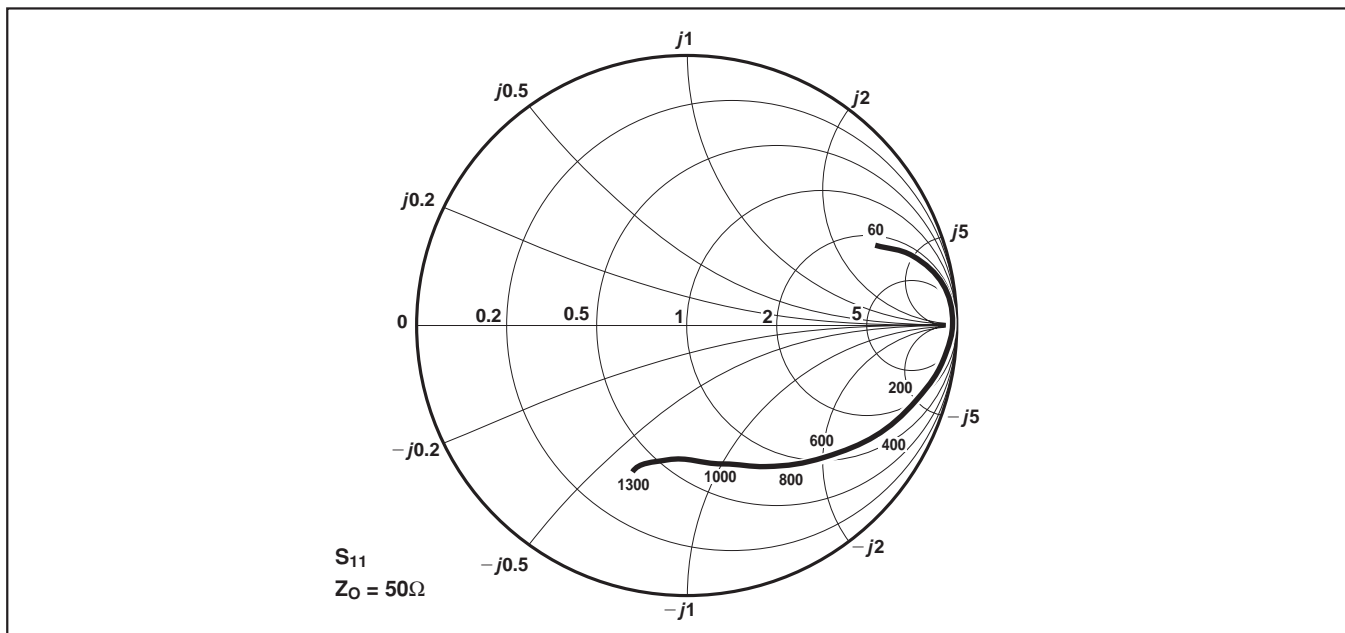

Fig. 6 Typical input impedance (frequencies in MHz)

SP4740



HEADQUARTERS OPERATIONS

GEC PLESSEY SEMICONDUCTORS

Cheney Manor, Swindon,
Wiltshire SN2 2QW, United Kingdom.
Tel: (0793) 518000
Fax: (0793) 518411

GEC PLESSEY SEMICONDUCTORS

P.O. Box 660017
1500 Green Hills Road,
Scotts Valley, California 95067-0017,
United States of America.
Tel: (408) 438 2900
Fax: (408) 438 5576

CUSTOMER SERVICE CENTRES

- **FRANCE & BENELUX** Les Ulis Cedex Tel: (1) 64 46 23 45 Tx: 602858F
Fax : (1) 64 46 06 07
- **GERMANY** Munich Tel: (089) 3609 06-0 Tx: 523980 Fax : (089) 3609 06-55
- **ITALY** Milan Tel: (02) 66040867 Fax: (02) 66040993
- **JAPAN** Tokyo Tel: (03) 3296-0281 Fax: (03) 3296-0228
- **NORTH AMERICA Integrated Circuits and Microwave Products** Scotts Valley, USA
Tel (408) 438 2900 Fax: (408) 438 7023.
Hybrid Products, Farmingdale, USA Tel (516) 293 8686
Fax: (516) 293 0061.
- **SOUTH EAST ASIA** Singapore Tel: (65) 3827708 Fax: (65) 3828872
- **SWEDEN** Stockholm, Tel: 46 8 702 97 70 Fax: 46 8 640 47 36
- **UNITED KINGDOM & SCANDINAVIA**
Swindon Tel: (0793) 518510 Tx: 444410 Fax : (0793) 518582

These are supported by Agents and Distributors in major countries world-wide.

© GEC Plessey Semiconductors 1996 Publication No. DS3062 Issue No. 2.2 May 1996

This publication is issued to provide information only which (unless agreed by the Company in writing) may not be used, applied or reproduced for any purpose nor form part of any order or contract nor to be regarded as a representation relating to the products or services concerned. No warranty or guarantee express or implied is made regarding the capability, performance or suitability of any product or service. The Company reserves the right to alter without prior knowledge the specification, design or price of any product or service. Information concerning possible methods of use is provided as a guide only and does not constitute any guarantee that such methods of use will be satisfactory in a specific piece of equipment. It is the user's responsibility to fully determine the performance and suitability of any equipment using such information and to ensure that any publication or data used is up to date and has not been superseded. These products are not suitable for use in any medical products whose failure to perform may result in significant injury or death to the user. All products and materials are sold and services provided subject to the Company's conditions of sale, which are available on request.



**For more information about all Zarlink products
visit our Web Site at
www.zarlink.com**

Information relating to products and services furnished herein by Zarlink Semiconductor Inc. trading as Zarlink Semiconductor or its subsidiaries (collectively "Zarlink") is believed to be reliable. However, Zarlink assumes no liability for errors that may appear in this publication, or for liability otherwise arising from the application or use of any such information, product or service or for any infringement of patents or other intellectual property rights owned by third parties which may result from such application or use. Neither the supply of such information or purchase of product or service conveys any license, either express or implied, under patents or other intellectual property rights owned by Zarlink or licensed from third parties by Zarlink, whatsoever. Purchasers of products are also hereby notified that the use of product in certain ways or in combination with Zarlink, or non-Zarlink furnished goods or services may infringe patents or other intellectual property rights owned by Zarlink.

This publication is issued to provide information only and (unless agreed by Zarlink in writing) may not be used, applied or reproduced for any purpose nor form part of any order or contract nor to be regarded as a representation relating to the products or services concerned. The products, their specifications, services and other information appearing in this publication are subject to change by Zarlink without notice. No warranty or guarantee express or implied is made regarding the capability, performance or suitability of any product or service. Information concerning possible methods of use is provided as a guide only and does not constitute any guarantee that such methods of use will be satisfactory in a specific piece of equipment. It is the user's responsibility to fully determine the performance and suitability of any equipment using such information and to ensure that any publication or data used is up to date and has not been superseded. Manufacturing does not necessarily include testing of all functions or parameters. These products are not suitable for use in any medical products whose failure to perform may result in significant injury or death to the user. All products and materials are sold and services provided subject to Zarlink's conditions of sale which are available on request.

Purchase of Zarlink's I²C components conveys a licence under the Philips I²C Patent rights to use these components in an I²C System, provided that the system conforms to the I²C Standard Specification as defined by Philips.

Zarlink and the Zarlink Semiconductor logo are trademarks of Zarlink Semiconductor Inc.

Copyright 2002, Zarlink Semiconductor Inc. All Rights Reserved.

TECHNICAL DOCUMENTATION - NOT FOR RESALE
