



ULTRA LOW NOISE K-BAND HETERO JUNCTION FET

NE202 SERIES

FEATURES

- **LOW NOISE FIGURE:**
1 dB TYP at $f = 12$ GHz (NE202XX)
1.2 dB TYP at $f = 12$ GHz (NE202XX-1.4)
1.8 dB TYP at $f = 18$ GHz (NE20248)
- **HIGH ASSOCIATED GAIN:**
12 dB TYP at $f = 12$ GHz (NE20283A)
9 dB TYP at $f = 18$ GHz (NE20248)
- **n+ AlGaAs/UNDOPED GaAs HETERO-JUNCTION STRUCTURE**
- **GATE LENGTH:** $L_g = 0.3$ microns
- **GATE WIDTH:** $W_g = 200$ microns
- **PASSIVATION ON CHIP FOR HIGH RELIABILITY**

DESCRIPTION

The NE202 is a Hetero Junction FET that utilizes the hetero-junction between Si-doped AlGaAs and undoped GaAs to create high mobility electrons. Its excellent low noise and high associated gain make it suitable for satellite communications and commercial systems. The NE202 is available in two versions, NE202XX for high performance low noise applications and the NE202XX-1.4 for gain stage applications. The device is available in chip and two Hermetic Packages.

ABSOLUTE MAXIMUM RATINGS (TA = 25°C)

SYMBOLS	PARAMETERS	UNITS	RATINGS
V _{DS}	Drain to Source Voltage	V	4
V _{GS}	Gate to Source Voltage	V	-3
I _{DS}	Drain Current	mA	60
P _T	Total Power Dissipation	mW	200
T _{CH}	Channel Temperature	°C	175
T _{STG}	Storage Temperature	°C	-65 to +175
I _G	Gate Current	μA	10

OUTLINE DIMENSIONS

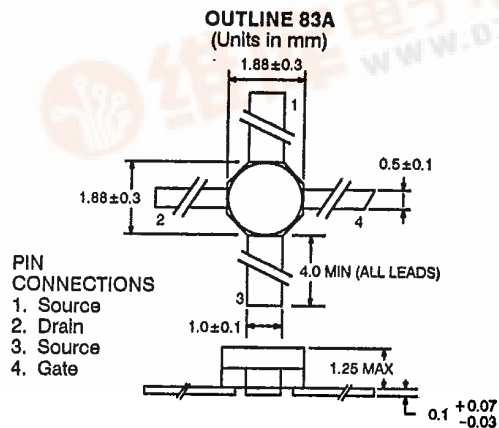
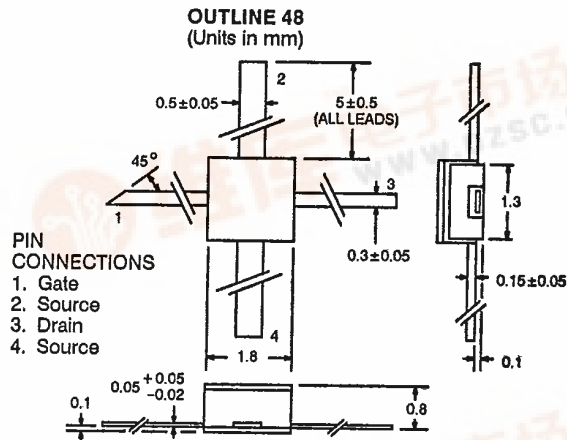
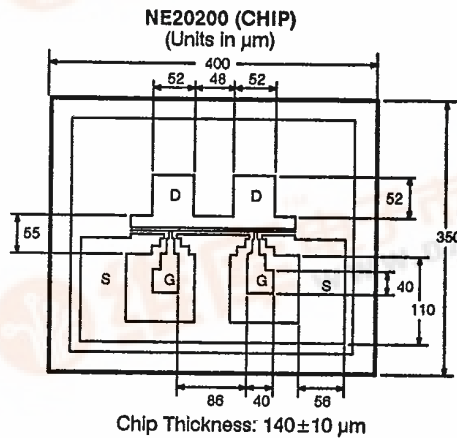

NE202 SERIES

ELECTRICAL CHARACTERISTICS (TA = 25°C)

PART NUMBER PACKAGE OUTLINE			NE20200 ¹ 00 (CHIP)			NE20200-1.4 ¹ 00 (CHIP)			NE20248 48			NE20283A 83A			NE20283A-1.4 83A			
SYMBOLS	PARAMETERS AND CONDITIONS	UNITS	MIN	TYP	MAX	MIN	TYP	MAX	MIN	TYP	MAX	MIN	TYP	MAX	MIN	TYP	MAX	
I _{DSX}	Drain to Source Leakage Current at V _{DS} = 4 V, V _{GS} = -3 V	μA			100			100			100			100			100	
I _{DSS}	Saturated Drain Current at V _{DS} = 2 V, V _{GS} = 0	mA	12	30	60	12	30	60	12	30	60	12	30	60	12	30	60	
I _{GSO}	Gate to Source Leakage Current at V _{GS} = -3 V, I _{DS} = 0	μA		1	10		1	10		1	10		1	10		1	10	
V _{GS (OFF)}	Gate to Source Cutoff Voltage at V _{DS} = 2 V, I _{DS} = 100 μA	V	-0.3	-0.8	-2	-0.3	-0.8	-2	-0.3	-0.8	-2	-0.3	-0.8	-2	-0.3	-0.8	-2	
GM	Transconductance at V _{DS} = 2 V, I _{DS} = 10 mA	mS	30	45	70	30	45	70	30	45	70	30	45	70	30	45	70	
NF	Noise Figure ² at V _{DS} = 2 V, I _{DS} = 10 mA, f = 12 GHz f = 18 GHz	dB dB		1	1.2		1.2	1.4			1.6	1.8		1	1.2		1.2	1.4
GA	Associated Gain at V _{DS} = 2 V, I _{DS} = 10 mA, f = 12 GHz f = 18 GHz	dB dB	11	12		10	11		7.5	9		11	12		10	11		
P _{1dB}	Power Output at 1 dB Gain Compression, V _{DS} = 2 V, I _{DS} = 10 mA, f = 12 GHz	dBm		9			9			9			9			9		
R _{TH}	Thermal Resistance (Channel-to-Ambient)	°C/W			260 ³			260 ³						700			700	

Notes:

- RF performance is determined by packaging and testing 10 chips per wafer; wafer rejection criteria for standard devices is 2 rejects for 10 samples.
- Typical values of noise figures are those obtained when 50% of the devices from a large number of lots were individually measured in a circuit with the input individually tuned to obtain the minimum value. Maximum values are criteria established on the production line as a "go-no-go" screening test with the fixture tuned for the "generic" type but not for each specimen.
- R_{TH} (channel to case) for chip mounted on copper heat sink.

NE20200 TYPICAL NOISE PARAMETERS*

FREQ. (GHz)	NF _{OPT} (dB)	GA (dB)	Γ _{OPT} **		Rn/50
			(MAG)	(ANG)	
1	0.30	23.7	0.82	8	0.75
2	0.30	20.5	0.80	15	0.60
4	0.37	17.2	0.74	31	0.55
6	0.52	15.3	0.70	44	0.50
8	0.68	13.9	0.66	58	0.45
10	0.84	12.9	0.62	72	0.42
12	1.00	12.0	0.58	86	0.40
14	1.15	11.3	0.54	98	0.38
16	1.31	10.7	0.51	110	0.36
18	1.47	10.1	0.48	122	0.34
20	1.63	9.6	0.46	132	0.32
22	1.82	9.1	0.44	141	0.30
24	2.03	8.6	0.42	148	0.27
26	2.22	8.0	0.42	156	0.25
28	2.43	7.5	0.42	161	0.22
30	2.70	6.9	0.41	167	0.20

NE20283A TYPICAL NOISE PARAMETERS*

FREQ. (GHz)	NF _{OPT} (dB)	GA (dB)	Γ _{OPT} **		Rn/50
			(MAG)	(ANG)	
2	0.35	20.5	0.76	29	0.77
4	0.40	17.2	0.76	57	0.60
6	0.50	15.3	0.70	82	0.41
8	0.70	13.9	0.61	110	0.28
10	0.90	12.9	0.55	141	0.14
12	1.10	12	0.50	168	0.10
14	1.20	11	0.46	-161	0.09
16	1.35	10	0.44	-137	0.07
18	1.50	8.5	0.43	-113	0.05

*V_{DS} = 2 V, I_{DS} = 10 mA

** Γ_{OPT} includes bond wires.

Bond wires used during testing:

Gate: 2 wires total, 1 per bond pad, 0.013" long each wire.

Drain: 2 wires total, 1 per bond pad, 0.015" long each wire.

Source: 4 wires total, 2 per side, 0.007" long each wire.

Noise parameters from 1 to 18 GHz are measured.

Noise parameters from 20 to 30 GHz are interpolated.

TYPICAL PERFORMANCE CHARACTERISTICS (T_A = 25°C)

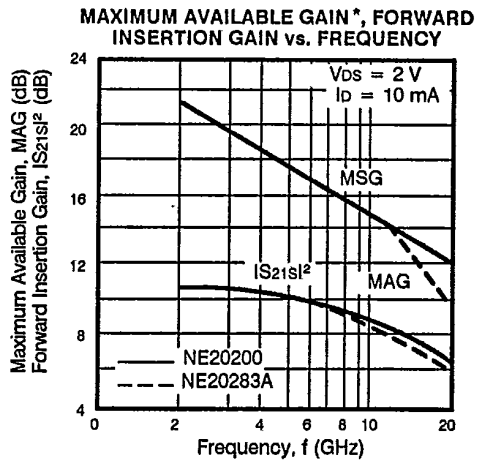
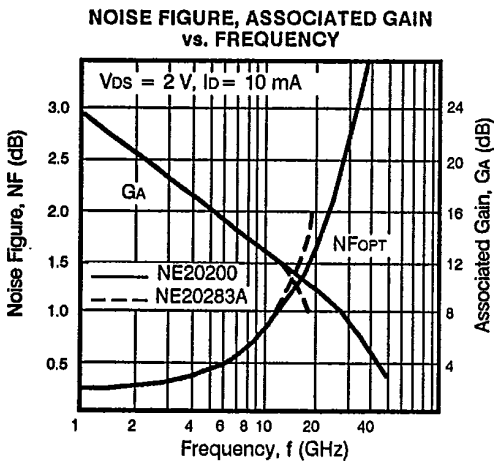
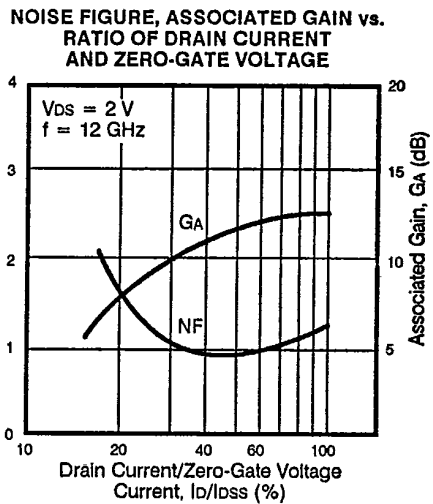
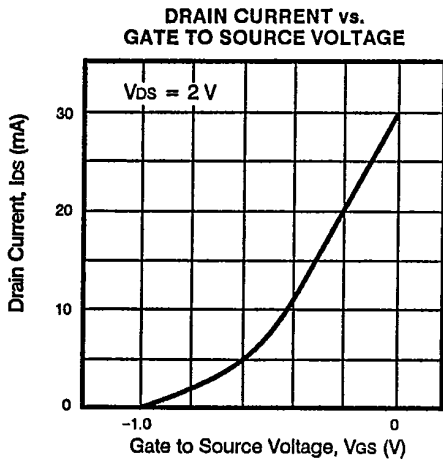
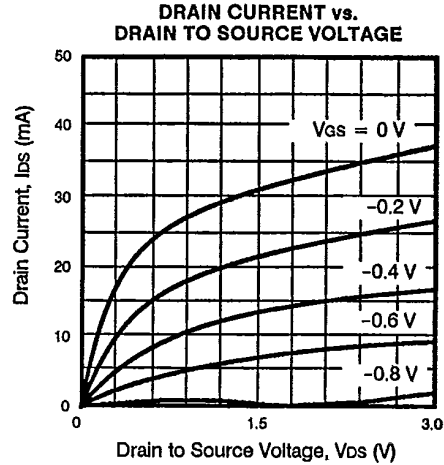
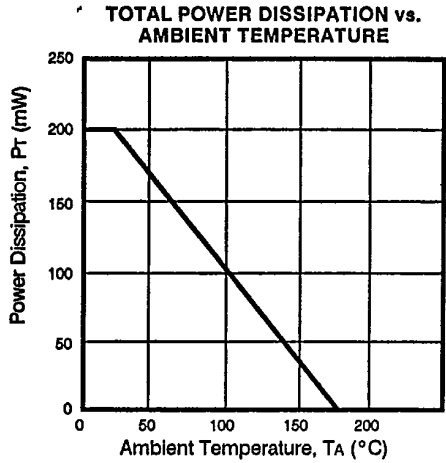

3

*Gain Calculations: $MAG = \frac{|S_{21}|}{|S_{12}|} (K - \sqrt{K^2 - 1})$. When $K \leq 1$, $MAG = MSG$

$MSG = \frac{|S_{21}|}{|S_{12}|}$, $K = \frac{1 + |\Delta|^2 - |S_{11}|^2 - |S_{22}|^2}{2|S_{12}||S_{21}|}$, $\Delta = S_{11}S_{22} - S_{21}S_{12}$

NE20200 EQUIVALENT CIRCUIT

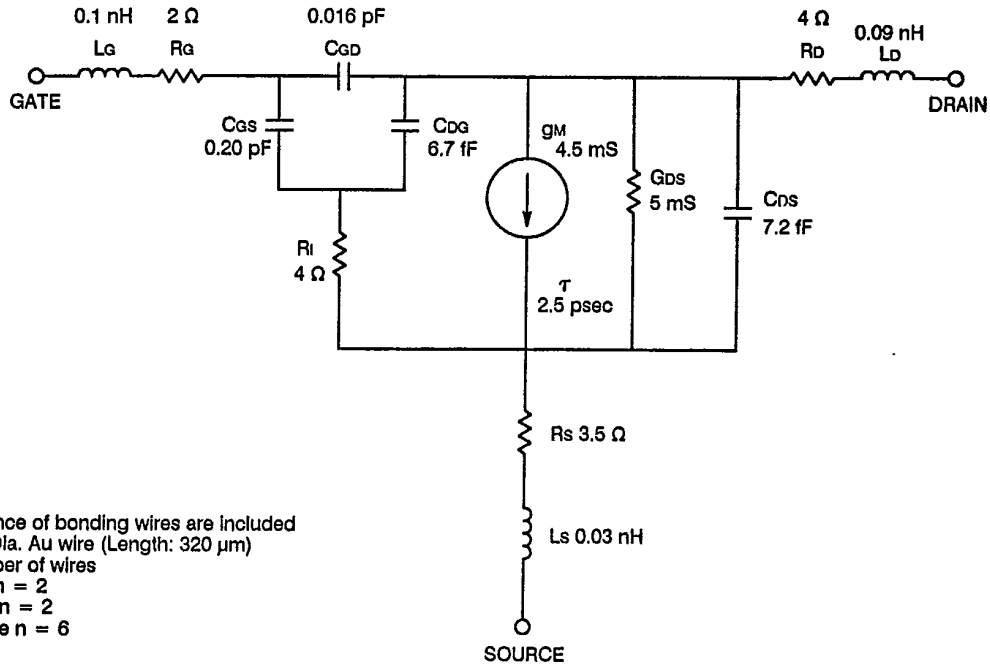

$I_{DS} = 10$ mA
 $V_{DS} = 2$ V
 $L_g = 0.3$ μ m
 $W_g = 200$ μ m

Note: Inductance of bonding wires are included
 20 μ m Dia. Au wire (Length: 320 μ m)
 n: Number of wires
 Gate n = 2
 Drain n = 2
 Source n = 6

RECOMMENDED DIE ATTACHING AND BONDING CONDITIONS FOR THE NE20200 AND NE20200-1.4

- | | |
|--|--|
| <p>1) Die Attaching:</p> <ul style="list-style-type: none"> Solder : AuSn Temperature : 300 \pm 10$^{\circ}$C Atmosphere : N₂ Within 10 seconds | <p>2) Bonding:</p> <ul style="list-style-type: none"> Wire : 20μm diameter gold Method : Thermocompression Bonding Temperature : 260 \pm 10$^{\circ}$C Atmosphere : N₂ Within 5 minutes |
|--|--|

TYPICAL COMMON SOURCE SCATTERING PARAMETERS

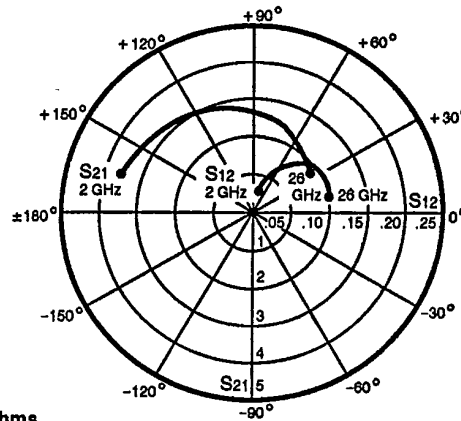
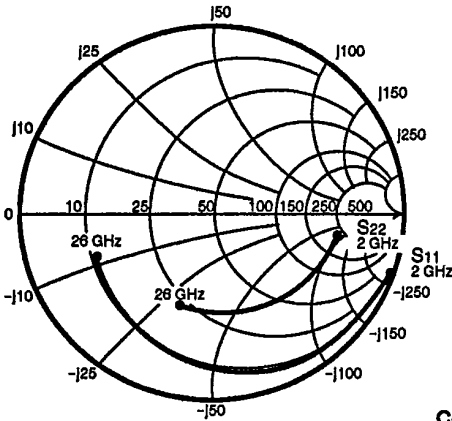

NE20200
Coordinates in Ohms
Frequency in GHz
(V_{DS} = 2 V, I_{DS} = 10 mA)

S-MAGN AND PHASE:
V_{DS} = 2 V, I_{DS} = 10 mA
FREQUENCY (GHz)

FREQUENCY (GHz)	S11	S21	S12	S22				
2.00	.99	-19	3.47	164	.03	77	.67	-11
3.00	.97	-28	3.40	156	.04	73	.66	-16
4.00	.96	-37	3.33	148	.05	67	.65	-21
5.00	.94	-46	3.23	140	.06	60	.63	-26
6.00	.92	-53	3.11	133	.06	61	.63	-30
7.00	.91	-61	3.02	126	.07	53	.62	-35
8.00	.89	-69	2.96	119	.08	49	.60	-40
9.00	.86	-76	2.84	113	.08	47	.59	-45
10.00	.85	-83	2.79	107	.09	44	.58	-50
11.00	.83	-90	2.73	100	.10	38	.58	-56
12.00	.81	-97	2.67	94	.10	34	.57	-61
13.00	.80	-103	2.60	88	.11	30	.57	-66
14.00	.78	-110	2.52	82	.11	25	.56	-70
15.00	.77	-115	2.45	76	.11	23	.55	-74
16.00	.76	-120	2.38	71	.11	20	.55	-76
17.00	.74	-125	2.31	66	.10	18	.54	-79
18.00	.73	-129	2.24	61	.11	17	.53	-80
19.00	.70	-133	2.13	58	.10	17	.52	-82
20.00	.70	-135	2.08	54	.10	17	.53	-84
21.00	.69	-138	2.04	52	.10	16	.53	-85
22.00	.69	-140	2.01	46	.10	16	.53	-87
23.00	.69	-145	1.90	42	.09	15	.52	-90
24.00	.67	-149	1.85	39	.10	16	.52	-96
25.00	.64	-154	1.84	36	.10	15	.50	-104
26.00	.62	-160	1.77	33	.10	15	.51	-107

Note: Bond wires are not de-embedded.
 Gate: 2 wires total, 1 per bond pad, 0.013" long each wire.
 Drain: 2 wires total, 1 per bond pad, 0.015" long each wire.
 Source: 4 wires total, 2 per side, 0.007" long each wire.
 Wire: 0.0008": diameter, gold.



TYPICAL COMMON SOURCE SCATTERING PARAMETERS

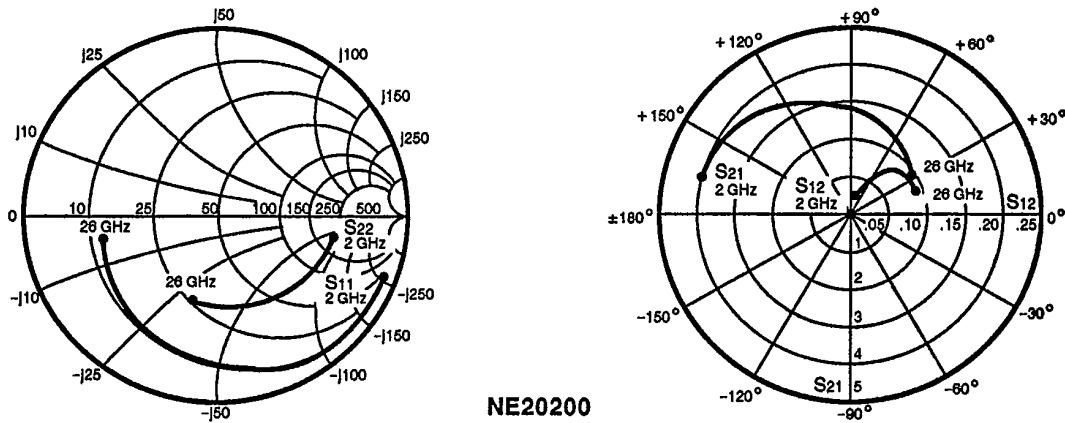

NE20200
Coordinates in Ohms
Frequency in GHz
(V_{DS} = 2 V, I_{DS} = 20 mA)

S-MAGN AND PHASE:
V_{DS} = 2 V, I_{DS} = 20 mA
FREQUENCY (GHz)

FREQUENCY (GHz)	S ₁₁	S ₂₁	S ₁₂	S ₂₂				
2.00	.98	-21	4.10	163	.02	76	.65	-11
3.00	.97	-30	3.99	155	.03	72	.64	-16
4.00	.95	-40	3.90	146	.04	67	.63	-21
5.00	.93	-49	3.76	138	.05	60	.61	-26
6.00	.91	-56	3.59	131	.06	62	.61	-29
7.00	.89	-65	3.47	125	.07	54	.60	-34
8.00	.87	-73	3.37	118	.07	50	.58	-40
9.00	.84	-80	3.23	111	.07	47	.56	-44
10.00	.83	-87	3.16	105	.08	45	.56	-49
11.00	.81	-94	3.07	98	.09	39	.56	-55
12.00	.79	-101	2.99	92	.09	35	.55	-60
13.00	.78	-108	2.89	86	.09	31	.54	-65
14.00	.76	-114	2.79	80	.10	28	.53	-69
15.00	.75	-120	2.70	75	.09	25	.53	-73
16.00	.73	-125	2.62	70	.10	24	.53	-75
17.00	.73	-129	2.54	66	.09	23	.53	-78
18.00	.70	-134	2.46	61	.09	21	.51	-78
19.00	.68	-137	2.33	57	.09	21	.51	-80
20.00	.68	-139	2.27	54	.09	24	.51	-82
21.00	.67	-142	2.22	51	.09	22	.52	-83
22.00	.67	-144	2.19	46	.09	23	.52	-85
23.00	.67	-149	2.06	42	.09	24	.51	-88
24.00	.64	-153	2.03	39	.09	22	.51	-94
25.00	.63	-158	2.00	36	.10	22	.49	-102
26.00	.61	-164	1.92	33	.10	23	.50	-105

Note: Bond wires are not de-embedded.
 Gate: 2 wires total, 1 per bond pad, 0.013" long each wire.
 Drain: 2 wires total, 1 per bond pad, 0.015" long each wire.
 Source: 4 wires total, 2 per side, 0.007" long each wire.
 Wire: 0.0008": diameter, gold.

TYPICAL COMMON SOURCE SCATTERING PARAMETERS

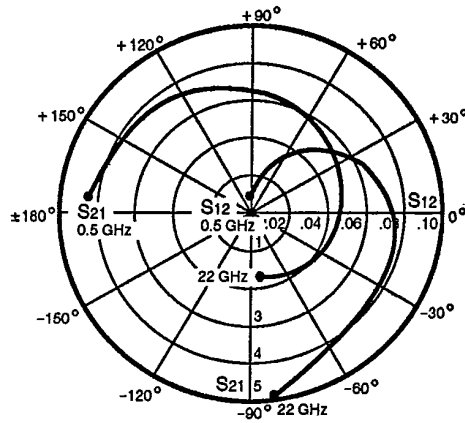
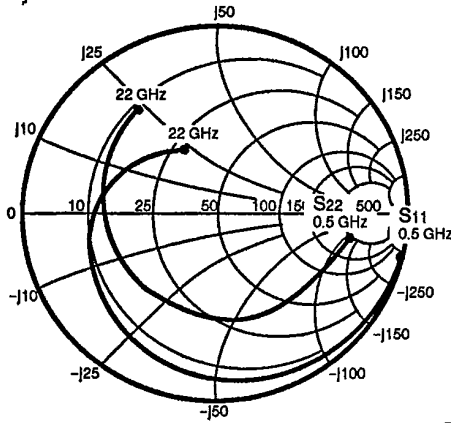

NE20248
Coordinates in Ohms
Frequency in GHz
(V_{DS} = 2 V, I_{DS} = 10 mA)

S-MAGN AND PHASE:
V_{DS} = 2 V, I_{DS} = 10 mA

FREQUENCY (GHz)	S ₁₁		S ₂₁		S ₁₂		S ₂₂	
.50	1.00	-8	4.16	173	.007	85	.71	-10
1.00	1.00	-15	4.16	164	.013	76	.74	-17
1.50	.99	-23	4.01	156	.019	71	.68	-19
2.00	.98	-30	3.95	150	.025	69	.64	-23
2.50	.97	-37	3.95	143	.031	60	.63	-31
3.00	.96	-45	3.86	135	.036	54	.63	-38
3.50	.95	-52	3.77	128	.040	50	.63	-41
4.00	.94	-59	3.73	122	.045	46	.60	-45
4.50	.92	-67	3.68	115	.050	40	.58	-52
5.00	.90	-74	3.59	108	.054	35	.58	-60
5.50	.89	-80	3.51	101	.058	30	.58	-65
6.00	.87	-87	3.43	95	.061	28	.57	-69
6.50	.85	-94	3.35	88	.064	20	.55	-76
7.00	.84	-100	3.25	81	.066	15	.55	-83
7.50	.83	-105	3.15	76	.067	11	.55	-88
8.00	.81	-111	3.08	70	.069	8	.55	-91
8.50	.80	-116	3.01	64	.070	4	.53	-97
9.00	.79	-121	2.83	58	.072	1	.52	-103
9.50	.78	-126	2.86	53	.074	-3	.53	-109
10.00	.77	-131	2.81	47	.075	-6	.53	-114
10.50	.75	-136	2.75	41	.077	-10	.52	-120
11.00	.74	-141	2.68	36	.078	-14	.52	-127
11.50	.72	-145	2.61	30	.078	-18	.53	-133
12.00	.71	-150	2.56	24	.079	-21	.54	-138
12.50	.70	-154	2.50	19	.079	-25	.54	-143
13.00	.68	-159	2.44	13	.079	-28	.54	-148
13.50	.67	-163	2.38	8	.079	-31	.54	-154
14.00	.66	-167	2.33	3	.079	-34	.55	-159
14.50	.65	-171	2.28	-2	.080	-37	.56	-163
15.00	.64	-175	2.24	-7	.080	-39	.56	-169
15.50	.63	-179	2.21	-13	.081	-42	.57	-174
16.00	.61	177	2.17	-18	.083	-45	.58	-179
16.50	.60	173	2.13	-23	.083	-49	.60	176
17.00	.58	169	2.09	-28	.084	-52	.61	172
17.50	.57	164	2.06	-34	.085	-55	.62	167
18.00	.55	160	2.02	-39	.085	-59	.62	164
18.50	.54	157	1.96	-44	.084	-62	.62	161
19.00	.52	152	1.92	-50	.086	-64	.63	158
19.50	.51	149	1.88	-54	.088	-68	.63	154
20.00	.48	144	1.85	-60	.087	-72	.62	150
20.50	.46	141	1.82	-65	.087	-74	.62	147
21.00	.45	137	1.78	-70	.088	-76	.61	143
21.50	.44	134	1.72	-74	.087	-79	.63	144
22.00	.38	118	1.72	-81	.101	-83	.68	127



TYPICAL COMMON SOURCE SCATTERING PARAMETERS

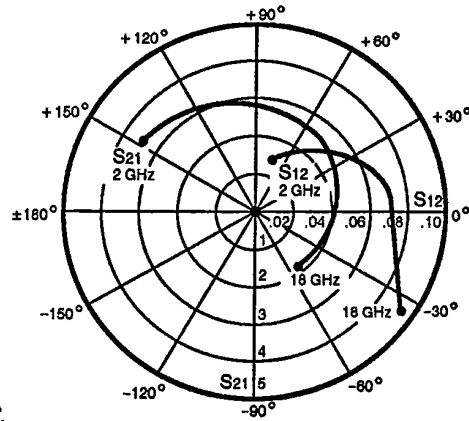
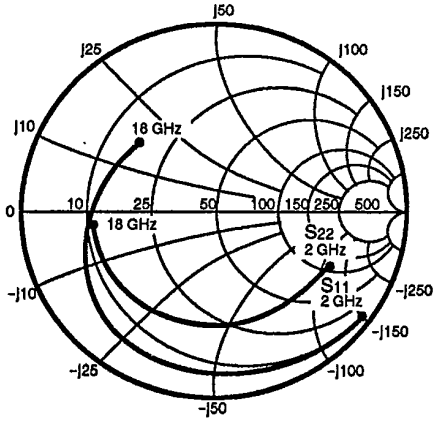

NE20283A
Coordinates in Ohms
Frequency in GHz
(V_{DS} = 2 V, I_{DS} = 10 mA)

S-MAGN AND PHASE:
V_{DS} = 2 V, I_{DS} = 10 mA
FREQUENCY (GHz)

FREQUENCY (GHz)	S ₁₁	S ₂₁	S ₁₂	S ₂₂				
2.00	.98	-34	3.55	148	.03	68	.65	-25
3.00	.94	-50	3.39	131	.04	55	.64	-37
4.00	.91	-65	3.22	116	.05	45	.63	-48
5.00	.88	-81	3.09	102	.06	34	.62	-60
6.00	.84	-95	2.91	87	.06	25	.61	-71
7.00	.82	-109	2.83	75	.07	18	.61	-81
8.00	.78	-120	2.63	62	.07	11	.60	-91
9.00	.76	-132	2.52	50	.07	5	.61	-100
10.00	.73	-144	2.36	40	.07	1	.61	-109
11.00	.71	-153	2.22	29	.07	-3	.61	-116
12.00	.69	-164	2.22	18	.07	-7	.62	-124
13.00	.66	-174	2.24	6	.08	-12	.62	-131
14.00	.62	176	2.09	-6	.07	-16	.61	-138
15.00	.60	166	2.01	-18	.08	-18	.61	-146
16.00	.58	156	2.00	-24	.08	-24	.62	-154
17.00	.55	145	2.00	-37	.08	-37	.63	-162
18.00	.51	133	2.00	-49	.09	-49	.63	-170

TYPICAL COMMON SOURCE SCATTERING PARAMETERS

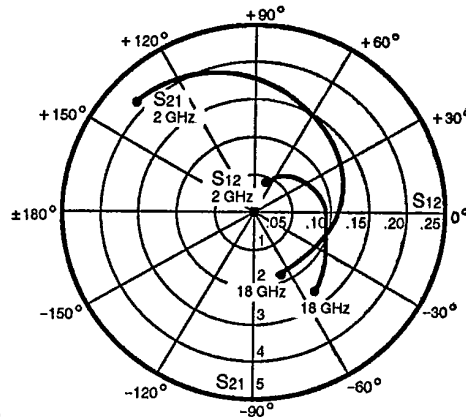
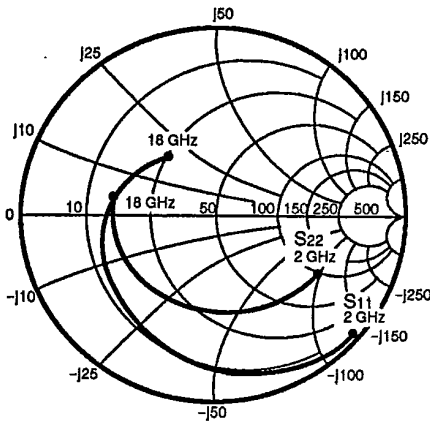

NE20283A
 Coordinates in Ohms
 Frequency in GHz
 ($V_{DS} = 2\text{ V}$, $I_{DS} = 20\text{ mA}$)

**S-MAGN AND PHASE:
 $V_{DS} = 2\text{ V}$, $I_{DS} = 20\text{ mA}$
 FREQUENCY (GHz)**

FREQUENCY (GHz)	S ₁₁		S ₂₁		S ₁₂		S ₂₂	
2.00	.95	-40	4.31	140	.04	62	.61	-32
3.00	.90	-57	3.97	124	.06	50	.59	-46
4.00	.86	-75	3.77	106	.07	38	.57	-60
5.00	.79	-91	3.43	91	.08	27	.54	-74
6.00	.75	-105	3.21	75	.09	18	.52	-86
7.00	.71	-119	2.98	62	.09	10	.52	-97
8.00	.68	-130	2.77	50	.09	4	.51	-106
9.00	.65	-141	2.59	37	.09	-3	.52	-115
10.00	.63	-152	2.43	26	.09	-6	.52	-125
11.00	.61	-161	2.28	15	.09	-12	.52	-133
12.00	.57	-172	2.22	2	.10	-19	.52	-141
13.00	.54	180	2.12	-8	.10	-22	.52	-148
14.00	.50	171	2.03	-19	.10	-27	.51	-155
15.00	.48	161	2.00	-32	.11	-33	.51	-163
16.00	.45	150	1.98	-40	.12	-36	.51	-172
17.00	.43	139	1.95	-54	.12	-45	.51	179
18.00	.39	127	1.95	-66	.13	-53	.51	169

