

NEC

NPN EPITAXIAL SILICON TRANSISTOR HIGH FREQUENCY LOW DISTORTION AMPLIFIER

NE461M02

FEATURES

- **HIGH COLLECTOR CURRENT:**
250 mA MAX
- **NEW HIGH GAIN POWER MINI-MOLD PACKAGE**
(SOT-89 TYPE)
- **HIGH OUTPUT POWER AT 1 dB COMPRESSION:**
27 dBm TYP at 1 GHz
- **HIGH IP₃:**
37 dBm TYP at 1 GHz

DESCRIPTION

The NE461M02 is an NPN silicon epitaxial bipolar transistor designed for medium power applications requiring high dynamic range and low intermodulation distortion. This device offers excellent performance and reliability at low cost through NEC's titanium, platinum, gold metallization system and direct nitride passivation of the surface of the chip. The NE461M02 is an excellent choice for low noise amplifiers in the VHF to UHF band and is suitable for CATV and other telecommunication applications.

OUTLINE DIMENSIONS (Units in mm)

PACKAGE OUTLINE M02

BOTTOM VIEW

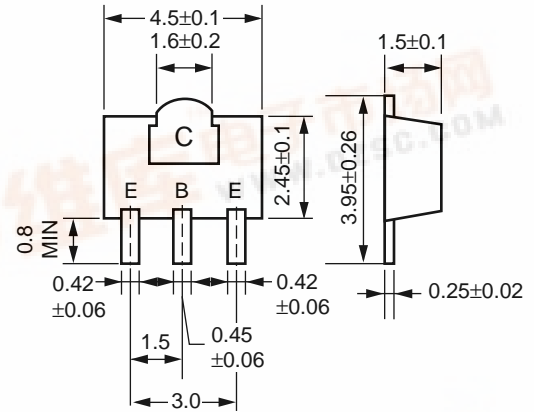

PIN CONNECTIONS

- E: Emitter
- C: Collector
- B: Base

ELECTRICAL CHARACTERISTICS (T_A = 25°C)

PART NUMBER EIAJ ¹ REGISTERED NUMBER PACKAGE OUTLINE			NE461M02 2SC5337 M02		
SYMBOLS	PARAMETERS AND CONDITIONS	UNITS	MIN	TYP	MAX
I _{CBO}	Collector Cutoff Current at V _{CB} = 20 V, I _E = 0	μA		0.01	5.0
I _{EBO}	Emitter Cutoff Current at V _{EB} = 2 V, I _C = 0	μA		0.03	5.0
h _{FE} ²	DC Current Gain at V _{CE} = 10 V, I _C = 50 mA		40	120	200
S _{21E} ²	Insertion Power Gain at V _{CE} = 10 V, I _C = 50 mA, f = 1 GHz	dB	7.0	8.3	
NF ¹	Noise Figure 1 at V _{CE} = 10 V, I _C = 50 mA, f = 500 MHz ³	dB		1.5	3.5
NF ²	Noise Figure 2 at V _{CE} = 10 V, I _C = 50 mA, f = 1 GHz ³	dB		2.0	3.5
IM ₂	2nd Order Intermodulation Distortion V _{CE} = 10 V, I _C = 50 mA, R _S = R _L = 75 Ω Pin = 105 dB μV/75 Ω, f ₁ = 190 MHz f ₂ = 90 MHz, f = f ₁ - f ₂	dB		59.0	
IM ₃	3rd Order Intermodulation Distortion V _{CE} = 10 V, I _C = 50 mA, R _S = R _L = 75 Ω Pin = 105 dB μV/75 Ω, f ₁ = 190 MHz f ₂ = 200 MHz, f = 2 × f ₁ - f ₂	dB		82.0	

Notes:

1. Electronic Industrial Association of Japan.
2. Pulsed measurement, pulse width ≤ 350 μs, duty cycle ≤ 2 %.
3. R_S = R_L = 50 Ω, tuned.

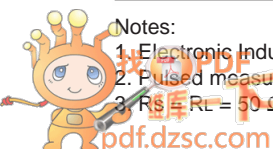

NE461M02

ABSOLUTE MAXIMUM RATINGS¹ (T_A = 25°C)

SYMBOLS	PARAMETERS	UNITS	RATINGS
V _{CB0}	Collector to Base Voltage	V	30
V _{CEO}	Collector to Emitter Voltage	V	15
V _{EBO}	Emitter to Base Voltage	V	3.0
I _C	Collector Current	mA	250
P _T	Total Power Dissipation ²	W	2.0
T _J	Junction Temperature	°C	150
T _{STG}	Storage Temperature	°C	-65 to +150

Notes:

1. Operation in excess of any one of these parameters may result in permanent damage.
2. Device mounted on 0.7 mm x 16 cm² double-sided ceramic substrate (copper plating).

ORDERING INFORMATION

PART NUMBER	QUANTITY	PACKAGING
NE461M02-T1	1000	Tape & Reel

TYPICAL PERFORMANCE CURVES (T_A = 25°C)

COLLECTOR CURRENT VS. COLLECTOR TO EMITTER VOLTAGE

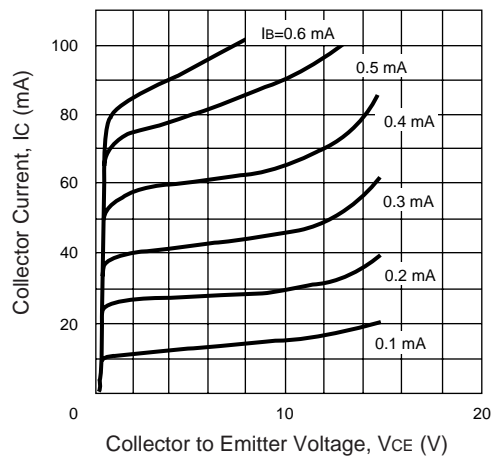

DC CURRENT GAIN VS. COLLECTOR CURRENT

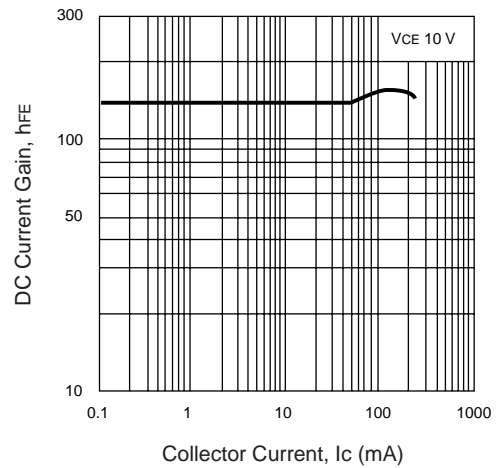

GAIN BANDWIDTH PRODUCT vs. COLLECTOR CURRENT

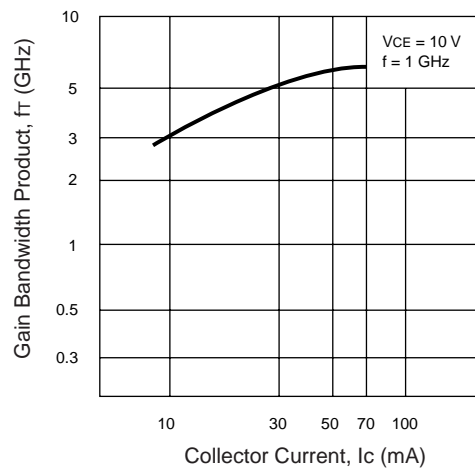

FEEDBACK CAPACITANCE vs. COLLECTOR TO BASE VOLTAGE

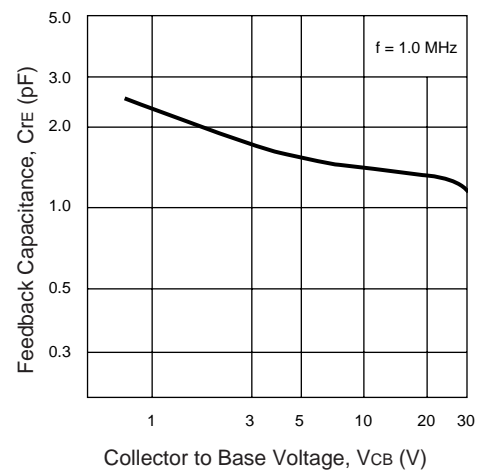

TYPICAL PERFORMANCE CURVES ($T_A = 25^\circ\text{C}$)

INSERTION POWER GAIN vs. COLLECTOR CURRENT

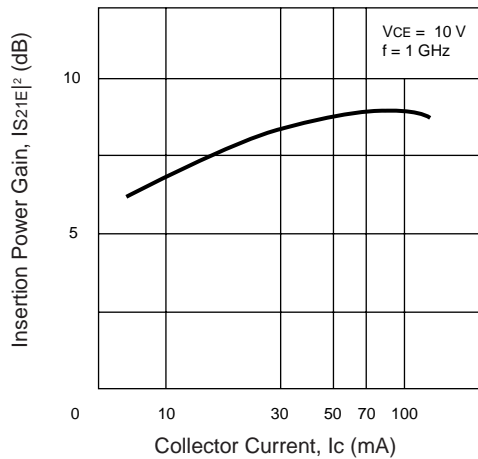

INSERTION POWER GAIN and MAXIMUM AVAILABLE GAIN vs. FREQUENCY

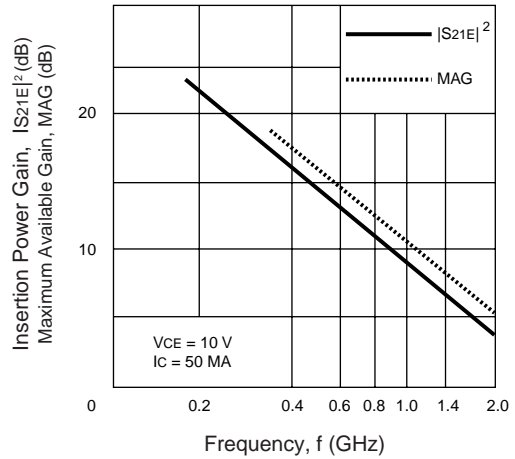

NOISE FIGURE vs. COLLECTOR CURRENT

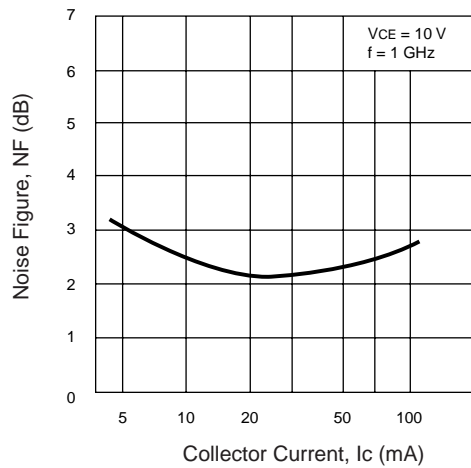

3RD ORDER INTERMODULATION DISTORTION, 2ND ORDER INTERMODULATION DISTORTION (+) & 2ND ORDER INTERMODULATION DISTORTION (-) vs. COLLECTOR CURRENT

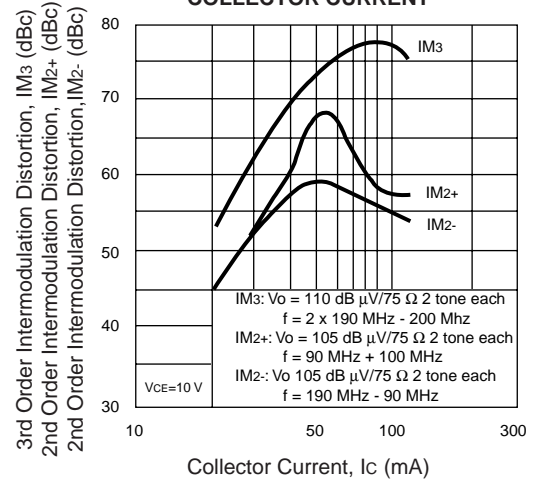

NE461M02

TYPICAL SCATTERING PARAMETERS (T_A = 25°C)

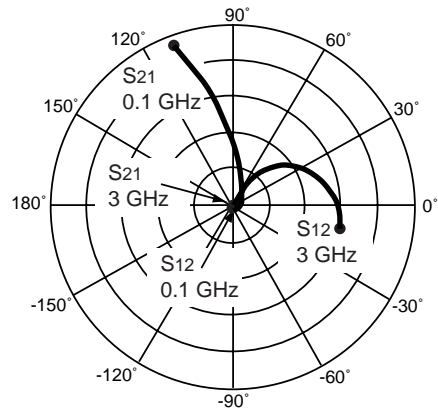
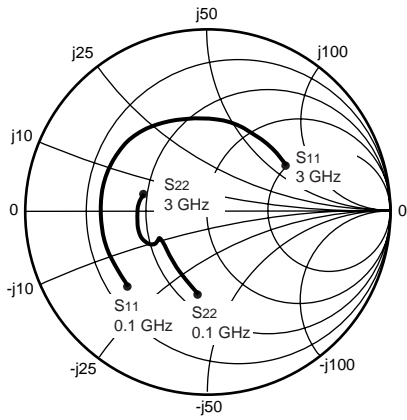

Coordinates in Ohms
Frequency in GHz
V_{CE} = 10 V, I_c = 50 mA

NE461M02

V_{CE} = 5 V, I_c = 50 mA

FREQUENCY GHz	S ₁₁		S ₂₁		S ₁₂		S ₂₂		K	MAG ¹ (dB)
	MAG	ANG	MAG	ANG	MAG	ANG	MAG	ANG		
0.100	0.603	-142.0	22.351	109.2	0.031	47.3	0.456	-100.7	0.50	28.6
0.200	0.615	-165.0	11.847	95.2	0.042	52.4	0.345	-129.0	0.77	24.5
0.400	0.618	178.5	6.043	83.2	0.066	60.8	0.309	-147.0	0.97	19.6
0.600	0.616	168.9	4.072	75.1	0.092	63.4	0.307	-152.1	1.04	15.3
0.800	0.612	161.2	3.089	68.2	0.119	63.4	0.310	-153.5	1.06	12.7
1.000	0.607	154.4	2.506	61.8	0.146	62.2	0.315	-153.6	1.07	10.8
1.200	0.602	148.0	2.123	55.8	0.172	60.4	0.321	-153.3	1.07	9.3
1.400	0.596	142.0	1.858	50.2	0.198	58.2	0.328	-152.8	1.06	8.2
1.600	0.588	136.2	1.661	44.9	0.224	55.9	0.335	-152.2	1.06	7.3
1.800	0.581	130.6	1.514	39.8	0.250	53.3	0.341	-151.7	1.05	6.5
2.000	0.572	125.0	1.397	35.1	0.275	50.6	0.347	-151.5	1.04	5.9
2.200	0.563	119.6	1.307	30.3	0.300	47.8	0.353	-151.4	1.03	5.4
2.400	0.553	114.0	1.232	25.9	0.325	44.9	0.359	-151.4	1.02	5.0
2.600	0.544	108.4	1.169	21.6	0.349	41.9	0.363	-151.8	1.01	4.6
2.800	0.535	102.7	1.118	17.5	0.373	38.8	0.369	-152.4	1.00	4.5
3.000	0.527	97.0	1.074	13.4	0.396	35.6	0.373	-153.3	1.00	4.3

V_{CE} = 10 V, I_c = 50 mA

FREQUENCY GHz	S ₁₁		S ₂₁		S ₁₂		S ₂₂		K	MAG ¹ (dB)
	MAG	ANG	MAG	ANG	MAG	ANG	MAG	ANG		
0.100	0.599	-137.2	23.210	109.9	0.031	48.0	0.455	-97.0	0.48	28.7
0.200	0.602	-162.2	12.353	95.7	0.042	51.4	0.335	-125.3	0.75	24.7
0.400	0.601	179.8	6.307	83.5	0.066	60.0	0.295	-143.9	0.97	19.8
0.600	0.599	169.8	4.248	75.4	0.091	62.8	0.292	-149.2	1.03	15.6
0.800	0.596	161.9	3.220	68.4	0.117	63.0	0.295	-150.6	1.06	12.9
1.000	0.591	155.0	2.609	62.1	0.144	61.9	0.301	-150.7	1.07	11.0
1.200	0.586	148.5	2.208	56.1	0.169	60.2	0.309	-150.3	1.07	9.6
1.400	0.581	142.4	1.929	50.5	0.195	58.1	0.317	-149.7	1.06	8.4
1.600	0.573	136.6	1.722	45.2	0.220	55.8	0.325	-149.1	1.06	7.5
1.800	0.566	131.0	1.568	40.1	0.245	53.3	0.333	-148.6	1.05	6.7
2.000	0.557	125.5	1.444	35.3	0.270	50.7	0.340	-148.3	1.04	6.1
2.200	0.549	120.1	1.349	30.5	0.295	48.0	0.347	-148.2	1.03	5.6
2.400	0.540	114.5	1.269	26.1	0.319	45.1	0.354	-148.2	1.02	5.2
2.600	0.531	108.9	1.202	21.8	0.342	42.2	0.360	-148.6	1.01	4.8
2.800	0.523	103.2	1.148	17.6	0.366	39.1	0.366	-149.2	1.00	4.8
3.000	0.515	97.5	1.101	13.5	0.388	36.0	0.372	-150.1	0.99	4.5

Note:

1. Gain Calculations:

$$MAG = \frac{|S_{21}|}{|S_{12}|} (K \pm \sqrt{K^2 - 1}). \text{ When } K \leq 1, \text{ MAG is undefined and MSG values are used. } MSG = \frac{|S_{21}|}{|S_{12}|}, K = \frac{1 + |\Delta|^2 - |S_{11}|^2 - |S_{22}|^2}{2 |S_{12} S_{21}|}, \Delta = S_{11} S_{22} - S_{21} S_{12}$$

MAG = Maximum Available Gain

MSG = Maximum Stable Gain

TYPICAL SCATTERING PARAMETERS (T_A = 25°C)

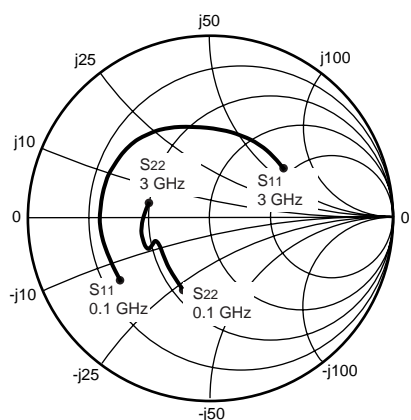

Coordinates in Ohms
Frequency in GHz
V_{CE} = 12 V, I_C = 100 mA

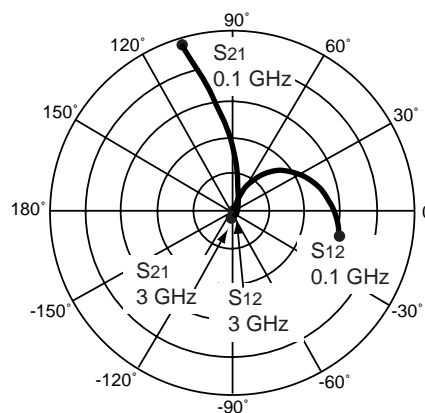

NE461M02

V_{CE} = 10 V, I_C = 100 mA

FREQUENCY GHz	S ₁₁		S ₂₁		S ₁₂		S ₂₂		K	MAG ¹ (dB)
	MAG	ANG	MAG	ANG	MAG	ANG	MAG	ANG		
0.100	0.596	-144.8	23.959	106.7	0.029	48.5	0.422	-108.4	0.56	29.2
0.200	0.601	-166.5	12.575	93.9	0.040	55.6	0.334	-135.7	0.82	25.0
0.400	0.601	177.5	6.386	82.7	0.066	63.6	0.308	-152.0	0.99	19.9
0.600	0.600	168.1	4.296	75.0	0.093	65.3	0.306	-156.5	1.04	15.4
0.800	0.597	160.4	3.258	68.3	0.120	64.7	0.309	-157.7	1.06	12.9
1.000	0.593	153.6	2.640	62.1	0.147	63.1	0.313	-157.8	1.06	11.0
1.200	0.588	147.2	2.236	56.3	0.174	60.9	0.318	-157.4	1.06	9.5
1.400	0.581	141.2	1.953	50.8	0.201	58.5	0.324	-156.6	1.06	8.4
1.600	0.574	135.3	1.747	45.6	0.227	55.9	0.330	-155.7	1.05	7.5
1.800	0.565	129.6	1.590	40.6	0.252	53.1	0.335	-154.9	1.05	6.7
2.000	0.556	124.1	1.468	35.8	0.277	50.3	0.341	-154.2	1.04	6.1
2.200	0.547	118.7	1.371	31.1	0.302	47.4	0.346	-153.5	1.03	5.5
2.400	0.535	113.0	1.292	26.6	0.325	44.3	0.351	-153.0	1.02	5.1
2.600	0.524	107.5	1.225	22.3	0.348	41.3	0.355	-152.8	1.02	4.7
2.800	0.515	101.8	1.170	18.1	0.371	38.2	0.359	-152.8	1.01	4.4
3.000	0.505	96.1	1.122	14.1	0.393	35.1	0.363	-153.0	1.00	4.2

V_{CE} = 12 V, I_C = 100 mA

FREQUENCY GHz	S ₁₁		S ₂₁		S ₁₂		S ₂₂		K	MAG ¹ (dB)
	MAG	ANG	MAG	ANG	MAG	ANG	MAG	ANG		
0.100	0.596	-143.1	24.061	106.9	0.029	48.3	0.416	-107.7	0.56	29.3
0.200	0.598	-165.5	12.640	94.0	0.040	55.1	0.328	-135.1	0.82	25.0
0.400	0.597	178.0	6.417	82.7	0.065	63.0	0.301	-151.6	0.99	19.9
0.600	0.595	168.4	4.313	74.9	0.093	64.8	0.299	-156.2	1.04	15.4
0.800	0.592	160.6	3.268	68.2	0.120	64.3	0.302	-157.4	1.06	12.8
1.000	0.588	153.7	2.647	62.0	0.147	62.8	0.306	-157.4	1.07	11.0
1.200	0.583	147.3	2.241	56.2	0.173	60.7	0.312	-156.9	1.07	9.5
1.400	0.576	141.3	1.957	50.7	0.199	58.3	0.318	-156.1	1.07	8.3
1.600	0.568	135.5	1.750	45.5	0.225	55.8	0.324	-155.2	1.06	7.4
1.800	0.560	129.9	1.593	40.5	0.250	53.1	0.330	-154.3	1.05	6.6
2.000	0.550	124.4	1.471	35.6	0.275	50.2	0.336	-153.5	1.04	6.0
2.200	0.540	119.0	1.373	31.0	0.300	47.4	0.342	-152.8	1.03	5.5
2.400	0.530	113.5	1.294	26.4	0.323	44.3	0.347	-152.3	1.03	5.0
2.600	0.520	107.9	1.228	22.1	0.346	41.3	0.353	-152.0	1.02	4.6
2.800	0.510	102.3	1.172	17.9	0.369	38.2	0.357	-151.9	1.01	4.4
3.000	0.502	96.7	1.123	13.8	0.391	35.0	0.362	-152.2	1.01	4.1

Note:

1. Gain Calculations:

$$MAG = \frac{|S_{21}|}{|S_{12}|} (K \pm \sqrt{K^2 - 1})$$

When K ≤ 1, MAG is undefined and MSG values are used. $MSG = \frac{|S_{21}|}{|S_{12}|}$, $K = \frac{1 + |\Delta|^2 - |S_{11}|^2 - |S_{22}|^2}{2 |S_{12}| |S_{21}|}$, $\Delta = S_{11} S_{22} - S_{21} S_{12}$

MAG = Maximum Available Gain

MSG = Maximum Stable Gain

EXCLUSIVE NORTH AMERICAN AGENT FOR **NEC** RF, MICROWAVE & OPTOELECTRONIC SEMICONDUCTORS