



NEC's NPN SILICON HIGH FREQUENCY TRANSISTOR

NE856 SERIES

FEATURES

- **HIGH GAIN BANDWIDTH PRODUCT:**
 $f_T = 7 \text{ GHz}$
- **LOW NOISE FIGURE:**
 1.1 dB at 1 GHz
- **HIGH COLLECTOR CURRENT:** 100 mA
- **HIGH RELIABILITY METALLIZATION**
- **LOW COST**

DESCRIPTION

NEC's NE856 series of NPN epitaxial silicon transistors is designed for low cost amplifier and oscillator applications. Low noise figures, high gain, and high current capability equate to wide dynamic range and excellent linearity. The NE856 series offers excellent performance and reliability at low cost. This is achieved by NEC's titanium/platinum/gold metallization system and their direct nitride passivated base surface process. The NE856 series is available in chip form and a Micro-x package for high frequency applications. It is also available in several low cost plastic package styles.

NE85600
NOISE FIGURE AND GAIN
vs. FREQUENCY

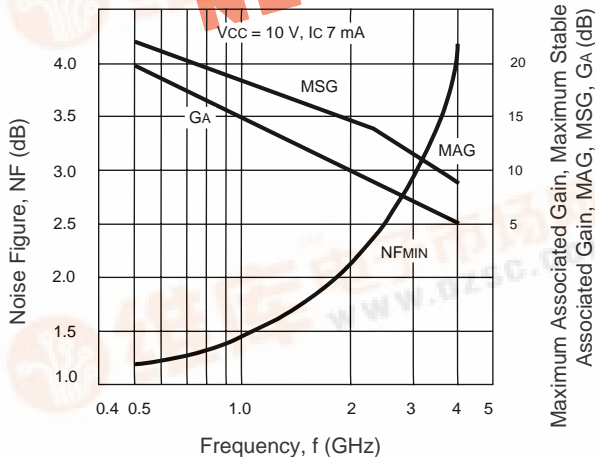

<p>00 (CHIP)</p>	<p>35 (MICRO-X)</p>
<p>32 (TO-92)</p>	<p>34 (SOT 89 STYLE)</p>
<p>18 (SOT 343 STYLE)</p>	<p>19 (3 PIN ULTRA SUPER MINI MOLD)</p>
<p>30 (SOT 323 STYLE)</p>	<p>33 (SOT 23 STYLE)</p>
<p>39 (SOT 143 STYLE)</p>	<p>39R (SOT 143R STYLE)</p>

PLEASE NOTE: Part numbers recommended in this datasheet are not for new design. Please call sales office for details: 85635



NE856 SERIES

ELECTRICAL CHARACTERISTICS (T_A = 25°C)

PART NUMBER EIAJ ¹ REGISTERED NUMBER PACKAGE OUTLINE			NE85600			NE85618 2SC5011 18			NE85619 2SC5006 19			NE85630 2SC4226 30			NE85632 2SC3355 32		
SYMBOLS	PARAMETERS AND CONDITIONS	UNITS	MIN	TYP	MAX	MIN	TYP	MAX	MIN	TYP	MAX	MIN	TYP	MAX	MIN	TYP	MAX
f _T	Gain Bandwidth Product at V _{CE} = 10 V, I _c = 20 mA V _{CE} = 3 V, I _c = 7 mA	GHz GHz		7.0			6.5		3.0	4.5			4.5			6.5	
NF	Noise Figure at V _{CE} = 10 V, I _c = 7 mA, f = 1 GHz V _{CE} = 10 V, I _c = 7 mA, f = 2 GHz	dB dB		1.1 2.1			1.4 2.1			1.4 2.2			1.3 2.2			1.4	
G _A	Associated Gain at V _{CE} = 10 V, I _c = 7 mA, f = 1 GHz f = 2 GHz	dB dB		10			13 7			12.5 6.5			12 6			10	
S _{21E} ²	Insertion Power Gain at V _{CE} = 10 V, I _c = 20 mA, f = 1 GHz f = 2 GHz	dB dB	7	9		11	13 7			12			12 6			9.5	
h _{FE}	Forward Current Gain ² at V _{CE} = 10 V, I _c = 20 mA V _{CE} = 3 V, I _c = 7 mA		50	120	300	50	120	300	80	120	160	40	110	250	50	120	300
I _{CBO}	Collector Cutoff Current at V _{CB} = 15 V, I _E = 0 mA	μA			1.0			1.0			1.0			1.0			1.0
I _{EBO}	Emitter Cutoff Current at V _{EB} = 1 V, I _C = 0 mA	μA			1.0			1.0			1.0			1.0			1.0
C _{re}	Feedback Capacitance ³ at V _{CB} = 3 V, I _E = 0 mA, f = 1 MHz V _{CB} = 10 V, I _E = 0 mA, f = 1 MHz	pF pF		0.5	1.0		0.5	0.9		0.7	1.5		0.7	1.5		0.65	1.0
P _T	Total Power Dissipation	mW			700			150			100			150			600
R _{TH} (J-A)	Thermal Resistance (J-A)	°C/W						833			1000			833			210

ELECTRICAL CHARACTERISTICS (T_A = 25°C)

PART NUMBER EIAJ ¹ REGISTERED NUMBER PACKAGE OUTLINE			NE85633 2SC3356 33			NE85634 2SC3357 34			NE85635 2SC3603 35			NE85639/39R 2SC4093 39		
SYMBOLS	PARAMETERS AND CONDITIONS	UNITS	MIN	TYP	MAX	MIN	TYP	MAX	MIN	TYP	MAX	MIN	TYP	MAX
f _T	Gain Bandwidth Product at V _{CE} = 10 V, I _c = 20 mA	GHz		7.0			6.5			7.0			9.0	
NF	Noise Figure at V _{CE} = 10 V, I _c = 7 mA, f = 1 GHz f = 2 GHz	dB dB		1.4	2.0		1.4			2.1	3.4		1.5	2.1
G _A	Associated Gain at V _{CE} = 10 V, I _c = 7 mA, f = 1 GHz f = 2 GHz	dB dB		9						10			13.5	8.5
S _{21E} ²	Insertion Power Gain at V _{CE} = 10 V, I _c = 20 mA, f = 1 GHz f = 2 GHz	dB dB		11.5			9.5		7	9			13	7
h _{FE}	Forward Current Gain ² at V _{CE} = 10 V, I _c = 20 mA		50	120	300	50	120	300	50	120	300	50	120	300
I _{CBO}	Collector Cutoff Current at V _{CB} = 15 V, I _E = 0 mA	μA			1.0			1.0			1.0			1.0
I _{EBO}	Emitter Cutoff Current at V _{EB} = 1 V, I _C = 0 mA	μA			1.0			1.0			1.0			1.0
C _{re}	Feedback Capacitance ³ at V _{CB} = 10 V, I _E = 0 mA, f = 1 MHz	pF		0.55	1.0		0.65	1.0		0.5	1.0		0.5	0.9
P _T	Total Power Dissipation	mW			200			2000 ⁴			580			200
R _{TH} (J-A)	Thermal Resistance (J to A)	°C/W			625			62.5 ⁴			590			500

Notes:

- Electronic Industrial Association of Japan.
- Pulse width ≤ 350 μs, duty cycle ≤ 2% pulsed.
- C_{re} measurement employs a three terminal capacitance bridge incorporating a guard circuit. The emitter terminal shall be connected to the guard terminal.
- With 2.5 cm² x 0.7 mm ceramic substrate (infinite heatsink).

ABSOLUTE MAXIMUM RATINGS¹ ($T_A = 25^\circ\text{C}$)

SYMBOLS	PARAMETERS	UNITS	RATINGS
V _{CB0}	Collector to Base Voltage	V	20
V _{CEO}	Collector to Emitter Voltage	V	12
V _{EB0}	Emitter to Base Voltage	V	3.0
I _c	Collector Current	mA	100
T _J	Junction Temperature	°C	150 ²
T _{STG}	Storage Temperature	°C	-65 to +150

Notes:

1. Operation in excess of any one of these parameters may result in permanent damage.
2. Maximum T_J for the NE85600 and NE85635 is 200°C.

TYPICAL PERFORMANCE CURVES ($T_A = 25^\circ\text{C}$)

**NE85633 AND NE85635
TOTAL POWER DISSIPATION vs.
AMBIENT TEMPERATURE**

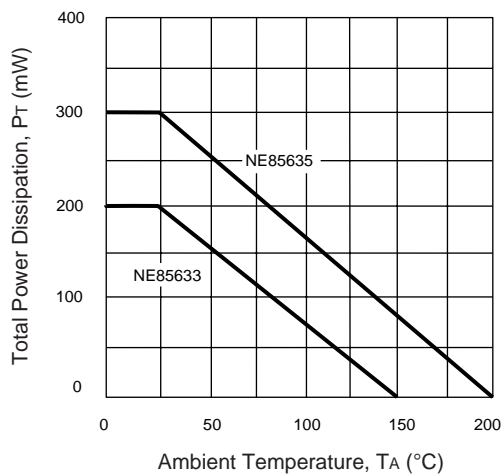

**NE85632 AND NE85634
TOTAL POWER DISSIPATION
vs. AMBIENT TEMPERATURE**

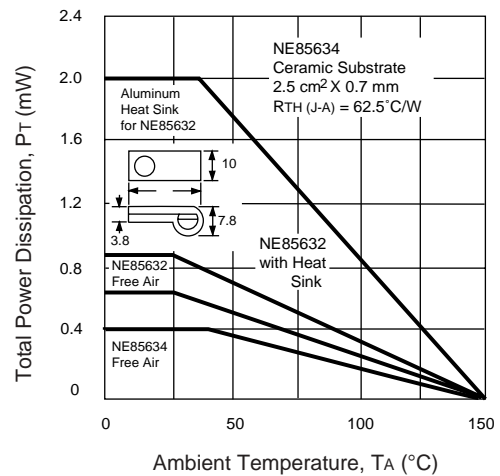

**COLLECTOR TO BASE
CAPACITANCE vs. COLLECTOR
TO BASE VOLTAGE**

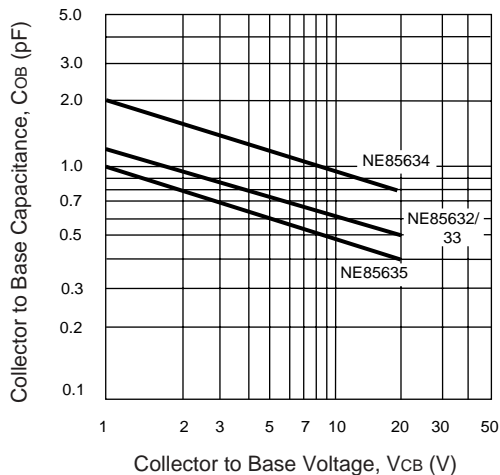

**FORWARD CURRENT GAIN
vs. COLLECTOR CURRENT**

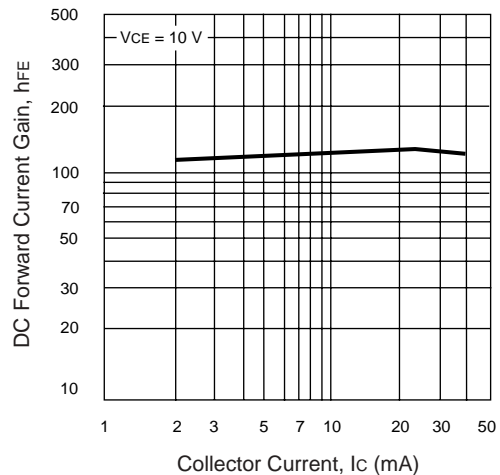

NE856 SERIES

TYPICAL PERFORMANCE CURVES (TA = 25 °C)

NE85634
FORWARD INSERTION GAIN
AND MAXIMUM AVAILABLE GAIN
vs. FREQUENCY

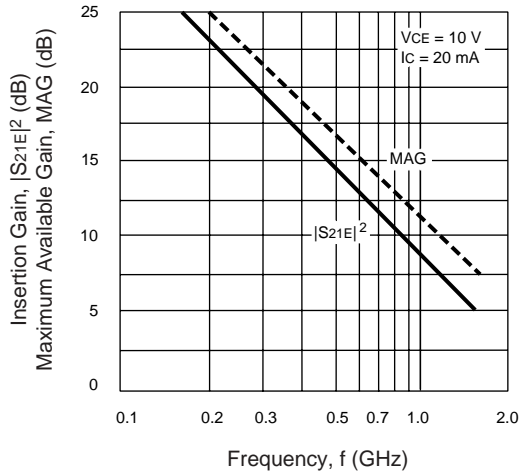

NE85635
FORWARD INSERTION GAIN
AND MAXIMUM AVAILABLE GAIN
vs. FREQUENCY

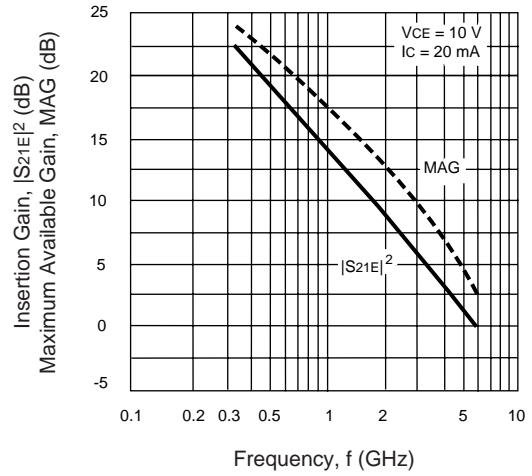

GAIN BANDWIDTH PRODUCT
vs. COLLECTOR CURRENT

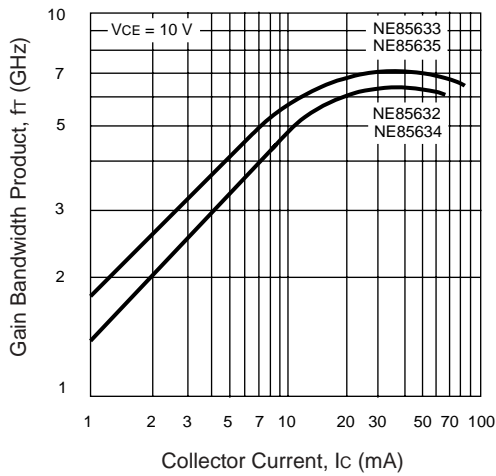

NE85632 AND NE85634
INTERMODULATION DISTORTION
vs. COLLECTOR CURRENT

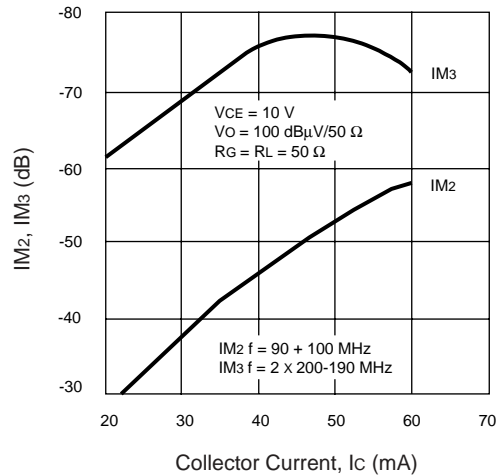

INSERTION GAIN vs.
COLLECTOR CURRENT

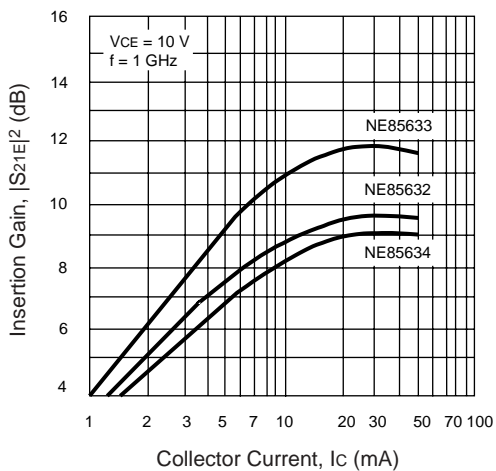

NE85635
INSERTION GAIN vs.
COLLECTOR CURRENT

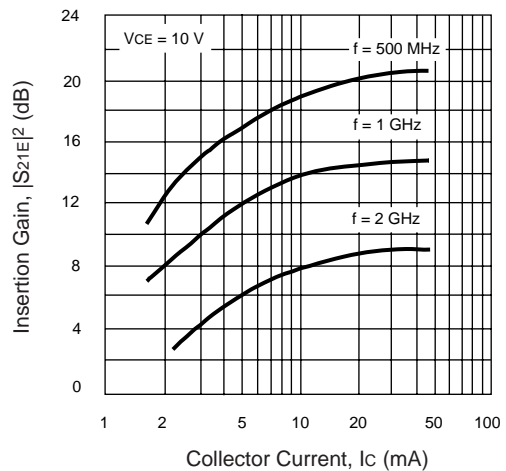

TYPICAL PERFORMANCE CURVES (T_A = 25°C)

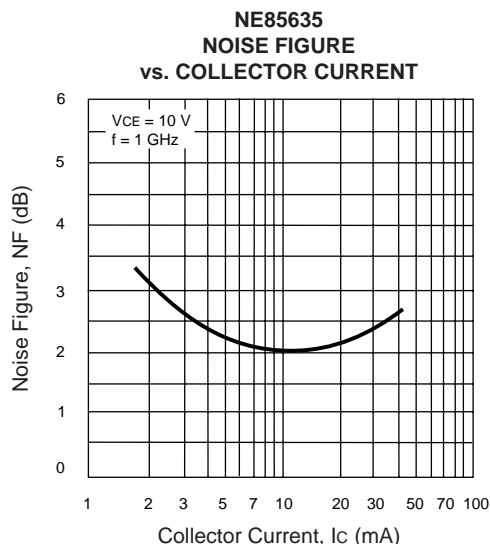
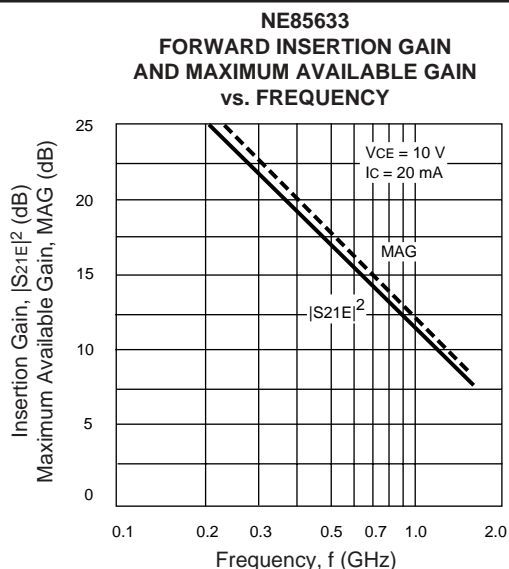

NE85600

TYPICAL NOISE PARAMETERS (T_A = 25°C)

FREQ. (MHz)	NF _{OPT} (dB)	GA (dB)	Γ _{OPT}		Rn/50
			MAG	ANG	
VCE = 10 V, IC = 7 mA					
500	1.2	21.86	0.20	138	0.13
1000	1.4	15.82	0.22	158	0.19
2000	2.2	11.87	0.49	176	0.23
4000	4.2	5.75	0.63	-141	0.47

NE85630

TYPICAL NOISE PARAMETERS (T_A = 25°C)

FREQ. (MHz)	NF _{OPT} (dB)	GA (dB)	Γ _{OPT}		Rn/50
			MAG	ANG	
VCE = 2.5 V, IC = 0.3 mA					
500	1.88	5.63	0.73	79	1.00
800	2.63	6.45	0.78	128	0.60
1000	3.14	5.03	0.79	149	0.17
VCE = 2.5 V, IC = 1.0 mA					
500	1.34	11.08	0.58	83	0.33
800	1.75	9.97	0.62	134	0.17
1000	1.98	8.33	0.63	152	0.10
1500	2.51	5.26	0.71	176	0.04
VCE = 2.5 V, IC = 3.0 mA					
500	1.10	14.41	0.37	92	0.15
800	1.32	11.67	0.44	143	0.08
1000	1.50	10.34	0.48	169	0.07
1500	1.88	7.04	0.56	177	0.05
2000	2.36	5.60	0.60	-150	0.17
VCE = 10 V, IC = 7.0 mA					
500	1.15	17.20	0.21	113	0.09
1000	1.27	12.67	0.32	177	0.15
1500	1.66	9.50	0.46	-141	0.52
2000	2.22	7.45	0.57	-118	0.67
3000	3.30	4.62	0.65	-92	0.70

NE85619

TYPICAL NOISE PARAMETERS (T_A = 25°C)

FREQ. (MHz)	NF _{OPT} (dB)	GA (dB)	Γ _{OPT}		Rn/50
			MAG	ANG	
VCE = 2.5 V, IC = 0.3 mA					
500	1.73	6.03	0.74	73	1.23
800	2.20	4.42	0.74	113	0.62
VCC = 2.5 V, IC = 1.0 mA					
500	1.15	11.26	0.60	75	0.36
800	1.50	9.15	0.58	117	0.20
1000	1.90	7.74	0.60	136	0.16
VCE = 2.5 V, IC = 3.0 mA					
500	1.00	14.83	0.43	80	0.17
800	1.22	11.81	0.40	122	0.10
1000	1.35	10.46	0.46	143	0.09
1500	1.70	7.66	0.64	174	0.04
VCE = 3 V, IC = 5.0 mA					
500	1.07	16.48	0.30	87	0.12
800	1.21	13.06	0.31	129	0.09
1000	1.34	11.56	0.37	149	0.08
1500	1.69	8.44	0.46	171	0.06
2000	2.17	6.99	0.52	-150	0.14
VCE = 10 V, IC = 7.0 mA					
500	1.10	18.42	0.27	83	0.13
800	1.24	14.90	0.28	123	0.10
1000	1.37	13.34	0.32	143	0.08
1500	1.72	10.39	0.42	172	0.06
2000	2.20	8.69	0.47	-152	0.14
2500	2.75	7.31	0.54	-134	0.45

NE856 SERIES

NE85632

TYPICAL NOISE PARAMETERS (T_A = 25°C)

FREQ. (MHz)	NF _{OPT} (dB)	G _A (dB)	Γ _{OPT}		Rn/50
			MAG	ANG	
V _{CE} = 4.5 V, I _C = 10 mA					
500	1.1		0.20	50	0.10
1000	1.6	30.72	0.34	159	0.10

NE85633

TYPICAL NOISE PARAMETERS (T_A = 25°C)

FREQ. (MHz)	NF _{OPT} (dB)	G _A (dB)	Γ _{OPT}		Rn/50
			MAG	ANG	
V _{CE} = 2.5 V, I _C = 0.3 mA					
500	1.62	9.23	0.71	82	0.80
800	2.45	6.11	0.72	118	0.55
1000	2.80	5.56	0.74	142	0.23
V _{CE} = 2.5 V, I _C = 1.0 mA					
500	1.15	12.70	0.59	84	0.33
800	1.56	9.20	0.57	120	0.18
1000	1.80	8.59	0.62	146	0.10
1500	2.30	5.52	0.70	170	0.05
2000	2.88	4.46	0.72	-161	0.13
V _{CE} = 2.5 V, I _C = 3 mA					
500	1.00	14.74	0.42	88	0.16
800	1.25	11.53	0.42	133	0.13
1000	1.40	10.03	0.49	152	0.07
1500	1.70	7.28	0.62	175	0.04
2000	2.05	5.94	0.68	-155	0.10
V _{CE} = 10 V, I _C = 7.0 mA					
500	1.85		0.37	87	0.20
1000	1.90	12.17	0.35	145	0.11
2000	2.10	7.8	0.54	-138	0.21
3000	2.70	4.68	0.67	-96	0.53
V _{CE} = 10 V, I _C = 10 mA					
500	1.29	17.58	0.1	96	0.11
800	1.50	13.41	0.2	-105	0.15
900	1.56	12.26	0.25	-95	0.16
1000	1.63	12.0	0.36	-117	0.17
1500	1.91	9.3	0.46	-58	0.52
V _{CE} = 10 V, I _C = 20 mA					
500	1.51	17.97	0.1	98	0.15
800	1.73	13.76	0.21	-93	0.20
900	1.80	12.65	0.26	-86	0.21
1000	1.86	12.2	0.38	-107	0.23
1500	2.13	9.5	0.44	-53	0.55

NE85634

TYPICAL NOISE PARAMETERS (T_A = 25°C)

FREQ. (MHz)	NF _{OPT} (dB)	G _A (dB)	Γ _{OPT}		Rn/50
			MAG	ANG	
V _{CE} = 4.5 V, I _C = 10 mA					
200	1.10	20.0	0.43	90	0.10
300	1.15	18.7	0.37	112	0.11
500	1.25	15.5	0.30	135	0.11
1000	1.80	9.4	0.22	170	0.12

NE85635

TYPICAL NOISE PARAMETERS (T_A = 25°C)

FREQ. (MHz)	NF _{OPT} (dB)	G _A (dB)	Γ _{OPT}		Rn/50
			MAG	ANG	
V _{CE} = 10 V, I _C = 7 mA					
500	1.02	20.24	0.15	117	0.12
700	1.29	18.11	0.27	138	0.09
1000	1.38	16.13	0.56	149	0.07
1500	1.91	13.70	0.66	177	0.06
2000	2.31	10.94	0.56	-151	0.18

NE85639

TYPICAL NOISE PARAMETERS (T_A = 25°C)

FREQ. (MHz)	NF _{OPT} (dB)	G _A (dB)	Γ _{OPT}		Rn/50
			MAG	ANG	
V _{CE} = 2.5 V, I _C = 0.3 mA					
500	1.60	8.65	0.69	79	1.25
800	2.00	6.26	0.75	121	0.45
V _{CE} = 2.5 V, I _C = 1.0 mA					
500	1.26	13.73	0.66	86	0.21
800	1.54	9.96	0.57	124	0.16
1000	1.75	8.99	0.60	148	0.09
1500	2.40	6.62	0.71	-173	0.05
V _{CE} = 2.5 V, I _C = 3.0 mA					
500	1.00	15.31	0.44	83	0.15
800	1.13	12.09	0.50	126	0.09
1000	1.25	11.04	0.50	155	0.07
1500	1.60	8.31	0.59	-170	0.06
2000	2.10	6.47	0.67	-146	0.21
V _{CE} = 10 V, I _C = 7 mA					
500	1.15	18.91	0.18	126	0.15
1000	1.50	13.5	0.32	169	0.09
1500	1.80	10.5	0.43	-174	0.14
2000	2.10	8.74	0.55	-142	0.20
3000	3.00	5.98	0.70	-107	0.93
V _{CE} = 10 V, I _C = 20 mA					
500	1.40	19.5	0.26	122	0.17
1000	1.70	14.5	0.35	175	0.11
1500	2.00	11.5	0.44	-159	0.16
2000	2.30	9.0	0.55	-135	0.23
3000	3.10	6.5	0.70	-104	1.01

TYPICAL COMMON EMITTER SCATTERING PARAMETERS

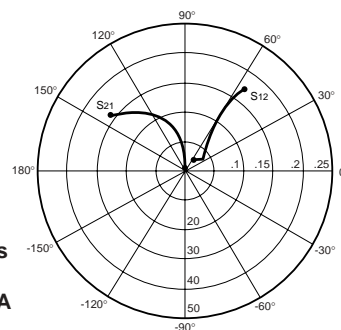
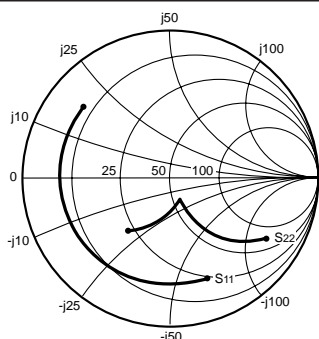

Coordinates in Ohms
Frequency in GHz
VCE = 10 V, IC = 20 mA

NE85600

VCE = 10 V, IC = 7 mA

FREQUENCY (MHz)	S11		S21		S12		S22		K	MAG ¹ (dB)
	MAG	ANG	MAG	ANG	MAG	ANG	MAG	ANG		
100	0.881	-40.9	15.380	155.0	0.026	67.0	0.910	-18.9	0.08	27.7
200	0.833	-75.0	13.961	138.0	0.041	50.7	0.760	-31.5	0.13	25.3
500	0.803	-129.8	8.644	108.8	0.056	30.3	0.487	-43.9	0.26	21.9
1000	0.792	-158.7	4.745	89.5	0.060	25.7	0.360	-46.5	0.49	19.0
1500	0.789	-170.5	3.260	78.7	0.063	26.9	0.330	-50.5	0.70	17.1
2000	0.788	-178.0	2.478	70.1	0.065	29.4	0.327	-56.4	0.90	15.8
2500	0.785	176.3	2.009	62.3	0.069	32.6	0.332	-63.4	1.05	13.3
3000	0.784	171.8	1.681	55.0	0.073	38.8	0.351	-69.6	1.17	11.1
4000	0.783	164.5	1.277	42.2	0.084	43.9	0.392	-84.4	1.27	8.7
5000	0.782	158.2	1.027	30.4	0.099	50.4	0.445	-97.1	1.26	7.1
6000	0.786	152.7	0.852	20.3	0.118	53.6	0.501	-108.5	1.13	6.4
7000	0.788	147.5	0.714	11.2	0.138	54.7	0.555	-118.2	1.03	6.1
8000	0.787	142.5	0.605	3.9	0.158	54.6	0.606	-127.1	0.96	5.8

VCE = 10 V, IC = 10 mA

100	0.834	-48.9	20.265	151.6	0.024	61.3	0.872	-23.6	0.13	29.3
200	0.800	-87.0	17.509	133.0	0.036	46.4	0.691	-38.0	0.15	26.9
500	0.786	-138.7	9.871	105.4	0.047	31.2	0.410	-50.7	0.31	23.2
1000	0.782	-163.4	5.268	88.0	0.051	26.9	0.291	-53.1	0.60	20.1
1500	0.781	-173.7	3.609	78.1	0.056	31.8	0.263	-57.0	0.81	18.1
2000	0.781	179.6	2.723	70.3	0.061	36.2	0.261	-62.1	0.98	16.5
2500	0.778	174.6	2.208	63.0	0.067	40.3	0.271	-68.8	1.10	13.3
3000	0.777	170.3	1.849	56.1	0.072	45.2	0.287	-75.3	1.21	11.3
4000	0.777	163.5	1.407	43.7	0.086	49.9	0.330	-88.9	1.28	9.0
5000	0.779	157.4	1.135	32.0	0.103	53.2	0.385	-100.4	1.23	7.5
6000	0.780	152.2	0.947	22.2	0.123	55.4	0.444	-110.2	1.13	6.7
7000	0.780	147.1	0.802	13.1	0.143	54.8	0.500	-119.2	1.04	6.3
8000	0.781	142.4	0.687	5.6	0.161	54.2	0.552	-127.5	0.98	6.3

VCE = 10 V, IC = 20 mA

100	0.753	-71.1	31.641	142.9	0.021	59.3	0.777	-33.9	0.11	31.8
200	0.756	-112.3	23.756	122.7	0.028	42.9	0.551	-50.5	0.20	29.3
500	0.771	-152.7	11.553	99.6	0.034	31.7	0.289	-62.9	0.45	25.3
1000	0.772	-170.7	5.982	85.6	0.041	38.0	0.195	-65.7	0.76	21.6
1500	0.774	-178.6	4.055	76.9	0.048	43.8	0.174	-69.6	0.96	19.3
2000	0.773	176.0	3.062	70.0	0.055	47.5	0.177	-75.7	1.11	15.4
2500	0.772	171.8	2.476	63.3	0.064	55.1	0.187	-82.3	1.18	13.3
3000	0.772	167.9	2.073	57.0	0.074	53.8	0.208	-87.1	1.20	11.8
4000	0.771	161.7	1.581	45.5	0.092	56.7	0.250	-98.6	1.23	9.5
5000	0.771	156.1	1.279	34.5	0.112	57.3	0.306	-107.4	1.18	8.0
6000	0.776	150.8	1.075	24.7	0.131	57.1	0.361	-115.4	1.11	7.1
7000	0.776	146.2	0.919	15.8	0.152	55.3	0.419	-122.2	1.02	6.9
8000	0.775	141.5	0.797	7.8	0.169	53.7	0.474	-128.8	0.97	6.7

Note:

1. Gain Calculations:

$$MAG = \frac{|S_{21}|}{|S_{12}|} (K \pm \sqrt{K^2 - 1}). \text{ When } K \leq 1, \text{ MAG is undefined and MSG values are used. } MSG = \frac{|S_{21}|}{|S_{12}|}, K = \frac{1 + |\Delta|^2 - |S_{11}|^2 - |S_{22}|^2}{2 |S_{12} S_{21}|}, \Delta = S_{11} S_{22} - S_{21} S_{12}$$

MAG = Maximum Available Gain

MSG = Maximum Stable Gain

NE856 SERIES

TYPICAL COMMON EMITTER SCATTERING PARAMETERS (TA = 25°C)

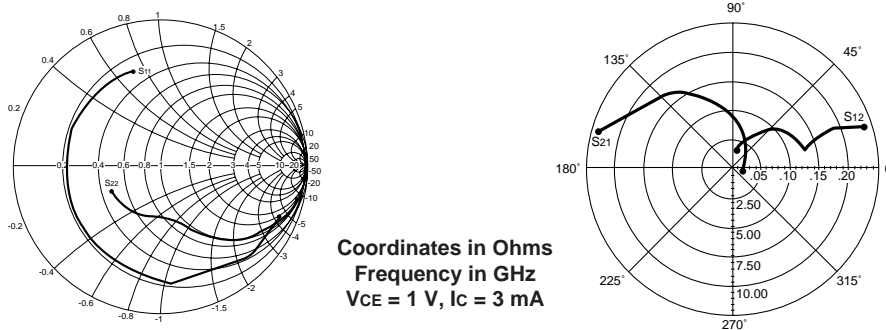

NE85618

VCE = 1 V, Ic = 1 mA

FREQUENCY (MHz)	S11		S21		S12		S22		K	MAG ¹ (dB)
	MAG	ANG	MAG	ANG	MAG	ANG	MAG	ANG		
50	0.985	-13.1	3.826	170.4	0.033	78.1	0.992	-6.5	0.10	20.6
100	0.980	-28.2	3.396	158.7	0.059	70.7	0.973	-12.9	0.10	17.6
200	0.906	-59.2	3.234	139.9	0.107	55.4	0.909	-23.9	0.10	14.8
300	0.861	-80.4	2.781	123.8	0.141	41.9	0.838	-32.5	0.19	12.9
400	0.822	-100.4	2.432	110.5	0.161	31.6	0.776	-39.3	0.23	11.8
500	0.793	-115.4	2.128	99.5	0.172	22.9	0.725	-44.8	0.30	10.9
600	0.769	-128.5	1.886	89.8	0.178	16.1	0.690	-49.6	0.36	10.3
700	0.754	-139.2	1.674	81.4	0.180	10.2	0.663	-54.0	0.42	9.7
800	0.748	-148.5	1.510	74.0	0.178	5.2	0.643	-58.3	0.48	9.3
900	0.740	-156.4	1.364	67.2	0.175	1.1	0.631	-62.5	0.55	8.9
1000	0.738	-163.6	1.247	60.8	0.171	-2.5	0.621	-66.5	0.62	8.6
1500	0.739	168.1	0.880	34.7	0.139	-11.8	0.607	-87.1	1.00	8.0
2000	0.748	146.4	0.676	15.4	0.108	-3.8	0.609	-107.4	1.53	3.7
2500	0.760	126.9	0.558	2.0	0.117	18.0	0.611	-127.8	1.63	2.1
3000	0.765	108.5	0.492	-8.8	0.175	26.4	0.608	-149.5	1.32	1.1

VCE = 1 V, Ic = 3 mA

50	0.899	-23.4	10.689	164.4	0.032	76.3	0.962	-12.8	0.09	25.2
100	0.865	-45.1	9.073	150.5	0.054	64.2	0.908	-24.4	0.10	22.3
200	0.794	-85.0	7.526	127.5	0.088	46.7	0.748	-41.5	0.15	19.3
300	0.724	-109.3	5.882	112.2	0.107	35.1	0.618	-52.2	0.27	17.4
400	0.699	-128.0	4.787	100.9	0.114	27.9	0.528	-59.5	0.34	16.2
500	0.673	-141.6	4.006	91.9	0.118	23.1	0.468	-64.6	0.44	15.3
600	0.668	-152.4	3.426	84.5	0.121	20.0	0.427	-68.8	0.52	14.5
700	0.657	-161.1	2.988	78.0	0.123	18.0	0.399	-72.5	0.61	13.9
800	0.656	-168.3	2.654	72.3	0.123	16.1	0.380	-76.0	0.69	13.3
900	0.653	-174.5	2.373	67.0	0.124	15.2	0.367	-79.5	0.77	12.8
1000	0.652	179.2	2.155	61.9	0.124	15.0	0.359	-82.8	0.85	12.4
1500	0.660	156.4	1.490	40.0	0.129	16.1	0.349	-99.9	1.16	8.2
2000	0.666	138.4	1.149	21.4	0.147	20.0	0.358	-117.2	1.30	5.6
2500	0.676	122.0	0.964	6.0	0.181	21.2	0.367	-134.9	1.24	4.3
3000	0.681	105.7	0.840	-8.5	0.228	17.7	0.374	-154.8	1.17	3.2

VCE = 2.5 V, Ic = 1 mA

50	0.971	-10.1	2.890	175.8	0.021	80.9	0.998	-3.6	0.03	21.4
100	0.962	-22.4	2.779	163.2	0.039	75.9	0.988	-8.2	0.07	18.5
200	0.930	-46.4	2.625	146.3	0.076	61.4	0.942	-17.3	0.12	15.4
300	0.895	-68.6	2.462	131.1	0.104	48.1	0.893	-24.7	0.17	13.7
400	0.854	-88.4	2.295	118.3	0.123	36.8	0.839	-31.0	0.23	12.7
500	0.823	-104.9	2.095	107.2	0.133	29.1	0.799	-35.9	0.27	12.0
600	0.798	-119.4	1.925	97.2	0.140	21.4	0.761	-40.0	0.33	11.4
700	0.774	-131.3	1.767	89.3	0.142	16.2	0.738	-44.5	0.38	10.9
800	0.766	-141.6	1.592	81.2	0.143	11.3	0.719	-48.0	0.44	10.5
900	0.758	-150.6	1.459	73.9	0.141	6.6	0.708	-51.6	0.50	10.1
1000	0.753	-158.9	1.329	67.1	0.137	2.7	0.708	-54.9	0.56	9.9
1500	0.743	170.2	0.952	41.5	0.111	-5.6	0.681	-73.7	0.94	9.3
2000	0.752	146.5	0.728	22.1	0.088	4.7	0.681	-92.0	1.40	5.4
2500	0.752	126.1	0.605	6.9	0.099	29.8	0.672	-110.5	1.55	3.5
3000	0.758	106.7	0.523	-4.0	0.152	36.7	0.672	-128.3	1.21	2.6

Note:

1. Gain Calculations:

$$\text{MAG} = \frac{|S_{21}|}{|S_{11}|} (K \pm \sqrt{K^2 - 1}). \text{ When } K \leq 1, \text{ MAG is undefined and MSG values are used. } \text{MSG} = \frac{|S_{21}|}{|S_{11}|}, K = \frac{1 + |\Delta|^2 - |S_{11}|^2 - |S_{22}|^2}{4|S_{11}S_{22}|}, \Delta = S_{11}S_{22} - S_{21}S_{12}$$

TYPICAL COMMON EMITTER SCATTERING PARAMETERS ($T_A = 25 \pm 2^\circ\text{C}$)

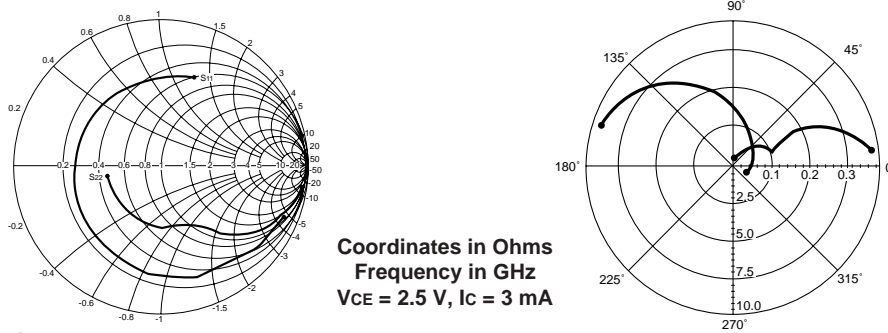

Coordinates in Ohms
Frequency in GHz
VCE = 2.5 V, IC = 3 mA

NE85619

VCE = 2.5 V, IC = 1 mA

FREQUENCY (MHz)	S11		S21		S12		S22		K	MAG ¹ (dB)
	MAG	ANG	MAG	ANG	MAG	ANG	MAG	ANG		
50	0.964	-14.4	3.517	167.7	0.022	85.5	0.990	-3.8	0.02	22.0
100	0.957	-26.7	3.474	160.8	0.047	76.1	0.972	-10.5	0.03	18.7
200	0.920	-50.4	3.216	144.0	0.084	59.3	0.932	-20.4	0.11	15.8
300	0.871	-71.6	2.886	129.9	0.116	47.6	0.881	-27.1	0.17	14.0
400	0.833	-90.1	2.583	117.1	0.134	37.4	0.828	-33.0	0.22	12.9
500	0.798	-105.2	2.297	106.5	0.146	29.9	0.782	-37.6	0.28	12.0
600	0.772	-118.0	2.044	97.1	0.150	23.6	0.745	-41.8	0.34	11.3
700	0.754	-129.0	1.839	89.1	0.153	17.5	0.721	-45.7	0.40	10.8
800	0.739	-138.8	1.674	81.8	0.152	13.0	0.704	-49.2	0.46	10.4
900	0.728	-147.1	1.530	75.1	0.152	9.1	0.689	-52.4	0.53	10.0
1000	0.721	-154.8	1.406	69.2	0.150	5.2	0.680	-55.7	0.59	9.7
1500	0.701	-174.1	1.016	44.4	0.124	-0.4	0.657	-71.1	0.97	9.1
2000	0.696	148.5	0.801	25.3	0.104	12.6	0.642	-86.1	1.45	4.9
2500	0.700	124.4	0.672	11.1	0.128	34.2	0.628	-102.3	1.43	3.3
3000	0.706	102.3	0.594	-0.2	0.198	38.6	0.610	-120.9	1.16	2.3

VCE = 2.5 V, IC = 3 mA

50	0.891	-22.1	9.720	163.1	0.022	83.5	0.980	-7.9	0.03	26.5
100	0.864	-39.3	9.323	153.2	0.045	68.3	0.915	-19.1	0.12	23.2
200	0.790	-71.8	7.861	132.7	0.071	51.0	0.806	-32.8	0.20	20.4
300	0.723	-96.9	6.425	118.0	0.092	40.8	0.682	-41.8	0.28	18.4
400	0.676	-116.0	5.336	106.4	0.097	33.1	0.602	-47.8	0.37	17.4
500	0.651	-130.3	4.518	97.4	0.102	30.0	0.545	-51.5	0.45	16.5
600	0.633	-141.5	3.876	89.8	0.106	27.5	0.501	-54.6	0.53	15.6
700	0.618	-151.1	3.401	83.5	0.107	25.5	0.476	-57.1	0.62	15.0
800	0.608	-159.1	3.031	77.6	0.109	24.3	0.456	-59.7	0.71	14.4
900	0.600	-166.0	2.733	72.3	0.110	23.4	0.445	-61.9	0.79	14.0
1000	0.597	-172.5	2.488	67.6	0.112	23.3	0.438	-64.5	0.85	13.5
1500	0.585	162.0	1.746	46.4	0.123	25.9	0.420	-75.8	1.13	9.3
2000	0.578	140.2	1.369	28.5	0.148	30.8	0.414	-88.1	1.23	6.8
2500	0.587	119.7	1.144	12.8	0.185	32.0	0.402	-101.5	1.19	5.3
3000	0.599	100.4	0.996	-1.6	0.243	27.2	0.385	-119.0	1.08	4.4
3500	0.625	83.1	0.887	-15.0	0.302	19.5	0.362	-142.2	1.02	3.8
4000	0.656	68.4	0.806	-26.5	0.365	8.4	0.363	-170.7	0.96	3.4

VCE = 3 V, IC = 7 mA

50	0.751	-31.8	19.537	157.2	0.021	80.6	0.935	-14.4	0.10	29.7
100	0.723	-58.1	17.622	143.1	0.038	64.8	0.808	-30.3	0.20	26.7
200	0.633	-98.5	12.973	120.5	0.055	46.8	0.633	-47.2	0.34	23.7
300	0.590	-122.8	9.717	107.1	0.064	44.0	0.496	-54.9	0.46	21.8
400	0.560	-139.6	7.662	97.7	0.069	40.8	0.417	-59.9	0.58	20.5
500	0.548	-151.6	6.301	90.5	0.073	40.5	0.365	-62.5	0.70	19.4
600	0.539	-160.4	5.317	84.3	0.078	40.2	0.334	-64.4	0.79	18.3
700	0.533	-167.9	4.613	79.2	0.084	40.5	0.311	-66.5	0.86	17.4
800	0.525	-174.3	4.074	74.4	0.089	41.0	0.299	-68.0	0.93	16.6
900	0.524	179.9	3.659	69.9	0.095	40.9	0.289	-69.7	0.98	15.9
1000	0.520	174.8	3.314	66.0	0.101	42.2	0.284	-71.5	1.02	14.3
1500	0.510	153.2	2.295	47.3	0.138	41.0	0.278	-78.9	1.10	10.3
2000	0.501	134.1	1.788	30.7	0.177	38.4	0.272	-89.3	1.13	7.9
2500	0.507	115.6	1.487	15.5	0.223	31.9	0.262	-100.4	1.10	6.3
3000	0.524	98.9	1.290	0.9	0.272	23.4	0.246	-117.0	1.05	5.4
3500	0.554	83.2	1.146	-13.1	0.322	14.7	0.22	-141.4	1.02	4.6
4000	0.598	69.6	1.035	-25.8	0.367	4.2	0.22	-174.0	0.98	4.5
4500	0.633	57.2	0.936	-37.6	0.411	-6.1	0.252	154.6	0.96	3.6

NE856 SERIES

TYPICAL COMMON EMITTER SCATTERING PARAMETERS (T_A = 25°C)

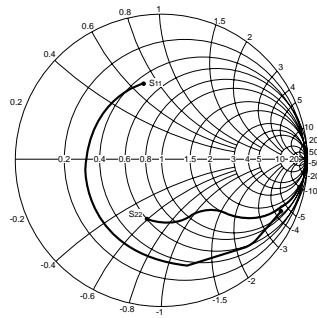

Coordinates in Ohms
Frequency in GHz
V_{CE} = 2.5 V, I_c = 3 mA

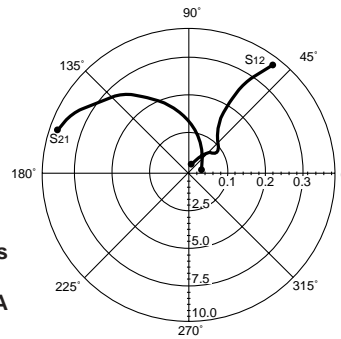

NE85630

V_{CE} = 2.5 V, I_c = 1 mA

FREQUENCY (MHz)	S ₁₁		S ₂₁		S ₁₂		S ₂₂		K	MAG ¹ (dB)
	MAG	ANG	MAG	ANG	MAG	ANG	MAG	ANG		
50	0.931	-14.9	3.753	166.3	0.025	85.1	0.997	-5.2	0.03	21.8
100	0.937	-29.6	3.500	161.0	0.052	75.0	0.972	-9.8	0.02	18.3
200	0.873	-55.1	3.138	141.0	0.087	59.1	0.920	-17.8	0.16	15.6
300	0.842	-76.3	2.775	127.5	0.114	47.7	0.866	-23.8	0.21	13.9
400	0.793	-95.1	2.460	115.5	0.127	39.2	0.806	-28.7	0.27	12.9
500	0.752	-110.5	2.161	105.0	0.134	32.1	0.765	-32.3	0.36	12.1
600	0.727	-123.0	1.903	96.5	0.138	28.1	0.734	-35.5	0.42	11.4
700	0.708	-133.9	1.717	88.8	0.138	23.9	0.714	-38.5	0.50	10.9
800	0.696	-143.3	1.555	82.0	0.134	22.0	0.700	-41.3	0.58	10.6
900	0.683	-151.5	1.414	76.4	0.128	21.0	0.687	-44.1	0.69	10.4
1000	0.676	-159.2	1.305	70.9	0.124	21.3	0.676	-46.8	0.78	10.2
1500	0.664	169.7	0.947	50.7	0.106	43.8	0.655	-60.8	1.22	6.7
2000	0.656	143.9	0.751	37.2	0.159	69.6	0.653	-76.4	1.10	4.8
2500	0.655	120.0	0.647	30.2	0.274	71.3	0.634	-92.7	0.94	3.7
3000	0.647	99.1	0.611	27.2	0.403	61.5	0.603	-110.7	0.94	1.8

V_{CE} = 2.5 V, I_c = 3 mA

50	0.884	-22.4	9.820	161.3	0.028	71.8	0.967	-10.9	0.22	25.4
100	0.839	-43.0	9.367	152.3	0.040	66.4	0.928	-18.5	0.10	23.7
200	0.731	-76.2	7.387	129.2	0.074	53.2	0.779	-30.1	0.26	20.0
300	0.653	-100.3	5.921	115.2	0.087	44.5	0.665	-36.1	0.38	18.3
400	0.600	-119.1	4.846	105.1	0.093	41.3	0.587	-39.9	0.49	17.2
500	0.572	-133.0	4.072	96.5	0.098	39.3	0.536	-42.0	0.60	16.2
600	0.552	-143.9	3.496	90.0	0.102	39.4	0.503	-43.8	0.70	15.3
700	0.540	-153.0	3.073	83.9	0.105	39.6	0.481	-45.5	0.80	14.7
800	0.529	-160.7	2.716	78.7	0.110	41.6	0.467	-47.4	0.88	13.9
900	0.524	-166.9	2.447	74.3	0.114	43.4	0.457	-49.3	0.95	13.3
1000	0.521	-173.7	2.242	69.7	0.118	45.6	0.448	-51.3	1.01	12.2
1500	0.517	161.3	1.589	52.2	0.157	56.6	0.431	-61.7	1.10	8.1
2000	0.510	139.8	1.253	37.9	0.219	60.2	0.433	-73.9	1.05	6.2
2500	0.525	119.5	1.060	26.8	0.300	58.2	0.431	-87.6	0.95	5.5
3000	0.537	102.7	0.930	17.9	0.390	51.9	0.418	-103.9	0.92	3.8

V_{CE} = 10 V, I_c = 7 mA

50	0.823	-18.6	15.781	164.3	0.013	80.1	0.955	-10.2	0.13	30.8
100	0.768	-39.4	14.539	149.3	0.025	69.2	0.885	-18.3	0.23	27.6
200	0.607	-75.7	11.892	127.5	0.039	59.0	0.705	-27.2	0.43	24.8
400	0.441	-121.3	7.582	102.9	0.055	56.8	0.538	-29.9	0.74	21.4
600	0.384	-146.2	5.346	90.3	0.070	60.5	0.481	-30.3	0.91	18.8
800	0.360	-163.3	4.104	81.2	0.084	62.9	0.457	-31.5	1.02	16.0
1000	0.350	-176.2	3.323	73.9	0.103	65.2	0.444	-34.0	1.05	13.7
1200	0.347	173.0	2.783	67.0	0.119	67.0	0.432	-38.0	1.10	11.8
1400	0.352	162.7	2.438	61.9	0.141	68.8	0.423	-40.2	1.07	10.8
1600	0.358	153.7	2.174	56.3	0.161	68.3	0.429	-43.9	1.04	10.1
1800	0.363	145.6	1.967	50.8	0.183	67.5	0.428	-47.7	1.02	9.4
2000	0.373	138.4	1.787	45.6	0.206	66.4	0.436	-51.9	0.98	9.4
2200	0.381	132.2	1.635	41.1	0.229	65.6	0.431	-56.4	0.98	8.5
2400	0.388	125.3	1.535	36.9	0.252	64.4	0.430	-60.6	0.95	7.8
2600	0.396	119.7	1.438	33.4	0.281	63.3	0.425	-65.2	0.93	7.1
2800	0.405	114.2	1.355	29.4	0.306	61.2	0.421	-69.9	0.92	6.5
3000	0.414	108.8	1.289	26.0	0.332	59.5	0.422	-74.3	0.90	5.9
3200	0.427	103.0	1.228	22.2	0.359	57.0	0.417	-79.4	0.89	5.3
3400	0.433	98.1	1.168	19.3	0.389	54.6	0.412	-84.6	0.88	4.8
3600	0.448	93.7	1.124	16.2	0.414	51.9	0.401	-90.2	0.88	4.3

TYPICAL COMMON EMITTER SCATTERING PARAMETERS (TA = 25°C)

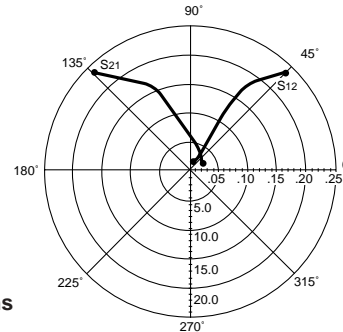
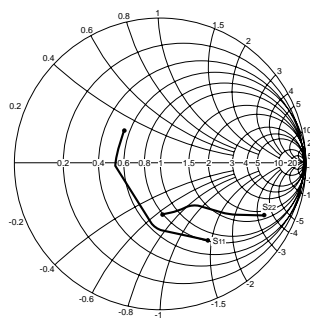

Coordinates in Ohms
Frequency in GHz
VCE = 10 V, IC = 10 mA

NE85632

VCE = 10 V, IC = 7 mA

FREQUENCY (MHz)	S11		S21		S12		S22		K	MAG ¹ (dB)
	MAG	ANG	MAG	ANG	MAG	ANG	MAG	ANG		
100	0.71	-50	16.63	141	0.02	70	0.85	-22	0.24	29.2
200	0.54	-84	11.97	119	0.04	55	0.66	-34	0.52	24.8
500	0.40	-134	5.98	91	0.08	58	0.44	-43	0.80	18.7
1000	0.34	-173	3.26	66	0.13	58	0.40	-52	0.95	14.0
1500	0.34	163	2.33	48	0.18	57	0.39	-70	0.97	11.1
2000	0.37	140	1.94	29	0.24	47	0.39	-88	0.89	9.1

VCE = 10 V, IC = 10 mA

100	0.62	-58	20.35	135	0.02	70	0.80	-26	0.31	30.1
200	0.45	-95	13.62	113	0.03	55	0.59	-36	0.71	26.6
500	0.35	-141	6.44	89	0.07	63	0.39	-42	0.93	19.6
100	0.31	-177	3.46	65	0.13	60	0.36	-51	0.99	14.3
1500	0.31	160	2.46	48	0.19	57	0.35	-70	0.98	11.1
2000	0.34	138	2.04	30	0.25	46	0.35	-88	0.91	9.1

VCE = 10 V, IC = 20 mA

100	0.45	-78	26.73	125	0.01	69	0.68	-31	0.77	34.3
200	0.32	-116	15.88	105	0.02	62	0.47	-37	1.14	26.7
500	0.28	-154	7.03	85	0.07	70	0.32	-40	1.00	20.0
1000	0.27	175	3.72	64	0.14	63	0.32	-50	0.97	14.2
1500	0.28	155	2.63	47	0.20	58	0.31	-70	0.97	11.2
2000	0.30	134	2.17	30	0.26	45	0.31	-88	0.93	9.2

Note:

1. Gain Calculations:

$$MAG = \frac{|S_{21}|}{|S_{12}|} (K \pm \sqrt{K^2 - 1})$$

. When $K \leq 1$, MAG is undefined and MSG values are used. $MSG = \frac{|S_{21}|}{|S_{12}|}$, $K = \frac{1 + |\Delta|^2 - |S_{11}|^2 - |S_{22}|^2}{2 |S_{12} S_{21}|}$, $\Delta = S_{11} S_{22} - S_{21} S_{12}$

MAG = Maximum Available Gain

MSG = Maximum Stable Gain

NE856 SERIES

TYPICAL COMMON EMITTER SCATTERING PARAMETERS (TA = 25°C)

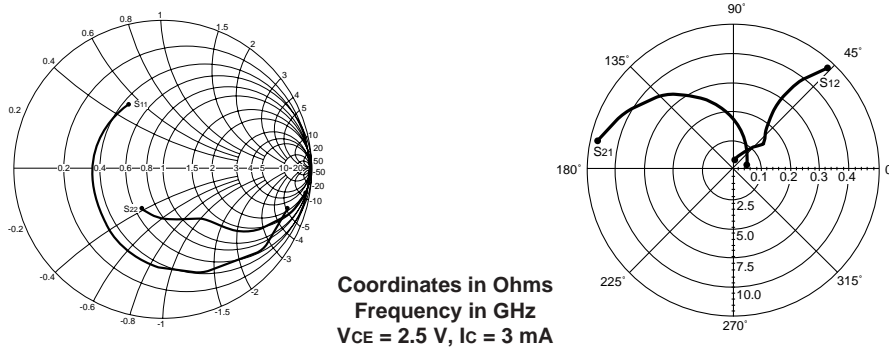

NE85633

VCE = 2.5 V, Ic = 1 mA

FREQUENCY (MHz)	S11		S21		S12		S22		K	MAG ¹ (dB)
	MAG	ANG	MAG	ANG	MAG	ANG	MAG	ANG		
50	0.960	-12.7	3.696	173.0	0.028	83.1	0.988	-4.5	0.01	21.2
100	0.942	-25.3	3.417	161.3	0.052	75.2	0.976	-9.6	0.08	18.2
200	0.898	-49.1	3.168	144.6	0.089	61.8	0.923	-18.5	0.13	15.5
400	0.800	-87.6	2.521	117.5	0.139	42.0	0.804	-30.4	0.27	12.6
600	0.717	-115.1	1.995	98.3	0.155	30.4	0.720	-38.0	0.43	11.1
800	0.672	-135.4	1.632	84.3	0.155	24.9	0.672	-44.0	0.58	10.2
1000	0.649	-150.7	1.391	72.4	0.146	23.8	0.642	-49.6	0.75	9.8
1500	0.627	178.2	1.032	51.6	0.131	40.4	0.608	-65.0	1.13	6.8
2000	0.624	154.3	0.842	37.3	0.186	63.7	0.582	-83.0	1.05	5.2
2500	0.615	131.9	0.747	28.0	0.308	65.6	0.547	-104.1	0.92	3.8
3000	0.601	112.1	0.709	21.7	0.448	55.4	0.498	-128.3	0.93	2.0

VCE = 2.5 V, Ic = 3 mA

50	0.891	-17.8	10.110	168.5	0.028	80.7	0.982	-9.3	0.06	25.6
100	0.876	-38.9	8.943	152.8	0.048	71.4	0.916	-18.7	0.09	22.7
200	0.749	-69.4	7.442	131.8	0.075	53.6	0.778	-31.2	0.27	20.0
400	0.603	-111.5	4.927	105.9	0.101	43.1	0.577	-42.8	0.48	16.9
600	0.533	-136.4	3.558	90.7	0.115	41.3	0.476	-47.2	0.70	14.9
800	0.501	-153.3	2.802	79.8	0.126	43.1	0.429	-50.5	0.86	13.5
1000	0.488	-165.9	2.303	70.6	0.138	46.3	0.403	-54.1	0.98	12.2
1500	0.478	169.8	1.660	52.6	0.182	53.4	0.370	-65.0	1.08	7.9
2000	0.483	151.2	1.337	37.9	0.249	56.1	0.348	-78.8	1.02	6.4
2500	0.489	132.7	1.155	25.6	0.337	53.6	0.324	-96.6	0.95	5.3
3000	0.499	116.9	1.042	15.4	0.433	46.2	0.298	-118.9	0.92	3.8

VCE = 3.5 V, Ic = 10 mA

100	0.602	-60.1	19.040	138.2	0.021	88.8	0.805	-31.7	0.12	29.6
200	0.471	-98.0	13.178	116.7	0.047	56.7	0.564	-45.5	0.54	24.5
400	0.389	-138.4	7.545	96.1	0.072	56.1	0.369	-50.6	0.81	20.2
600	0.370	-159.5	5.208	85.2	0.093	60.0	0.299	-51.8	0.94	17.5
800	0.367	-172.8	3.977	77.2	0.117	61.9	0.266	-53.8	1.00	15.3
1000	0.369	177.5	3.229	70.0	0.140	63.4	0.246	-56.3	1.03	12.6
1200	0.374	169.5	2.740	63.8	0.167	61.5	0.231	-58.6	1.03	11.1
1400	0.379	163.6	2.386	58.2	0.191	61.2	0.222	-61.2	1.04	9.7
1600	0.391	157.6	2.131	52.6	0.215	60.1	0.210	-64.9	1.04	8.7
1800	0.396	153.1	1.932	47.8	0.243	58.6	0.203	-68.7	1.02	8.1
2000	0.409	149.4	1.778	42.9	0.271	56.0	0.189	-73.2	1.00	8.2
2500	0.425	141.1	1.512	31.6	0.337	51.3	0.165	-83.7	0.97	6.5

Note:

1. Gain Calculations:

$$\text{MAG} = \frac{|S_{21}|}{|S_{12}|} (K \pm \sqrt{K^2 - 1})$$

When $K \leq 1$, MAG is undefined and MSG values are used. $\text{MSG} = \frac{|S_{21}|}{|S_{12}|}$, $K = \frac{1 + |\Delta|^2 - |S_{11}|^2 - |S_{22}|^2}{2 |S_{12} S_{21}|}$, $\Delta = S_{11} S_{22} - S_{21} S_{12}$

MAG = Maximum Available Gain

MSG = Maximum Stable Gain

TYPICAL COMMON EMITTER SCATTERING PARAMETERS (TA = 25°C)

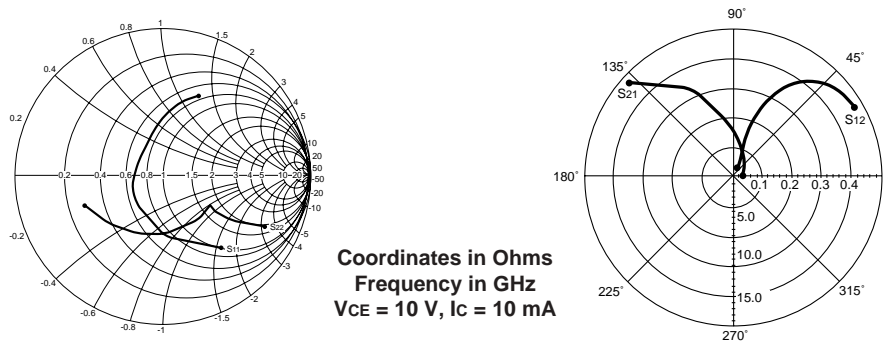

NE85634
VCE = 10 V, IC = 7 mA

FREQUENCY (MHz)	S11		S21		S12		S22		K	MAG ¹ (dB)
	MAG	ANG	MAG	ANG	MAG	ANG	MAG	ANG		
100	0.714	-42.6	14.567	144.0	0.031	69.3	0.840	-22.1	0.30	26.7
200	0.508	-77.9	11.129	121.0	0.047	63.0	0.636	-31.0	0.56	23.7
400	0.326	-119.5	6.585	98.1	0.072	65.1	0.478	-33.0	0.85	19.6
500	0.286	-132.9	5.409	91.8	0.086	66.9	0.452	-32.8	0.91	18.0
600	0.264	-144.5	4.579	86.5	0.096	68.7	0.431	-33.3	0.98	16.8
800	0.237	-162.6	3.553	78.1	0.124	70.9	0.415	-35.6	1.01	14.0
1000	0.225	-177.8	2.899	70.3	0.152	72.0	0.410	-38.5	1.02	11.9
1500	0.226	148.3	2.083	55.0	0.228	71.0	0.411	-50.3	0.99	9.6
2000	0.262	122.2	1.669	42.4	0.302	67.1	0.403	-66.5	0.96	7.4
2500	0.350	102.4	1.454	29.6	0.381	60.6	0.420	-87.4	0.89	5.8
3000	0.451	87.6	1.258	17.6	0.445	51.5	0.455	-113.6	0.86	4.5
3500	0.548	75.7	1.095	6.0	0.486	41.4	0.520	-139.5	0.85	3.5
4000	0.628	65.2	0.940	-4.4	0.500	31.0	0.593	-160.3	0.85	2.7

VCE = 10 V, IC = 10 mA

100	0.616	-50.5	18.431	138.3	0.028	68.0	0.777	-25.8	0.39	28.2
200	0.405	-87.2	12.799	115.2	0.043	65.4	0.565	-32.5	0.68	24.7
400	0.259	-127.0	7.121	95.1	0.072	70.0	0.426	-32.5	0.91	20.0
500	0.231	-140.2	5.796	89.6	0.086	70.8	0.409	-31.9	0.96	18.3
600	0.214	-150.9	4.893	84.9	0.098	71.7	0.391	-32.4	1.00	17.0
800	0.196	-168.7	3.757	77.2	0.129	73.0	0.379	-34.4	1.02	13.8
1000	0.188	176.2	3.081	69.7	0.160	73.5	0.377	-37.6	1.02	12.0
1500	0.194	143.1	2.202	55.3	0.239	70.3	0.378	-49.5	0.98	9.6
2000	0.232	118.4	1.766	43.0	0.309	65.5	0.369	-66.2	0.97	7.6
2500	0.320	100.2	1.537	30.9	0.386	58.7	0.385	-87.3	0.91	6.0
3000	0.421	86.8	1.338	18.8	0.446	50.0	0.418	-113.7	0.88	4.8
3500	0.523	75.7	1.176	7.1	0.481	40.3	0.484	-139.9	0.87	3.9
4000	0.607	65.2	1.015	-3.7	0.493	30.1	0.563	-160.3	0.86	3.1

VCE = 10 V, IC = 20 mA

100	0.410	-68.8	25.453	126.7	0.024	71.1	0.650	-31.2	0.57	30.3
200	0.252	-105.2	14.914	106.5	0.040	71.5	0.452	-32.8	0.84	25.7
400	0.177	-142.5	7.780	91.2	0.072	76.3	0.360	-29.6	0.97	20.3
500	0.163	-155.1	6.281	86.4	0.089	74.7	0.351	-29.3	0.99	18.5
600	0.155	-164.7	5.279	82.5	0.103	76.7	0.339	-29.7	1.01	16.5
800	0.148	178.8	4.043	75.7	0.137	75.9	0.334	-32.1	1.01	14.1
1000	0.146	164.9	3.292	69.3	0.171	74.1	0.334	-35.8	1.01	12.2
1500	0.157	133.3	2.352	56.3	0.250	69.7	0.337	-47.9	0.99	9.7
2000	0.197	111.2	1.877	44.2	0.321	63.5	0.327	-65.7	0.98	7.7
2500	0.285	95.9	1.643	32.5	0.392	56.4	0.339	-87.6	0.94	6.2
3000	0.387	84.5	1.440	21.1	0.446	48.0	0.372	-115.1	0.92	5.1
3500	0.489	74.5	1.274	9.2	0.476	38.7	0.439	-141.6	0.90	4.3
4000	0.576	65.0	1.112	-2.1	0.489	28.7	0.521	-161.3	0.88	3.6

Note:

1. Gain Calculations:

$$MAG = \frac{|S_{21}|}{|S_{12}|} (K \pm \sqrt{K^2 - 1})$$

When $K \leq 1$, MAG is undefined and MSG values are used. $MSG = \frac{|S_{21}|}{|S_{12}|}$, $K = \frac{1 + |\Delta|^2 - |S_{11}|^2 - |S_{22}|^2}{2 |S_{12} S_{21}|}$, $\Delta = S_{11} S_{22} - S_{21} S_{12}$

MAG = Maximum Available Gain

MSG = Maximum Stable Gain

NE856 SERIES

TYPICAL COMMON EMITTER SCATTERING PARAMETERS (TA = 25°C)

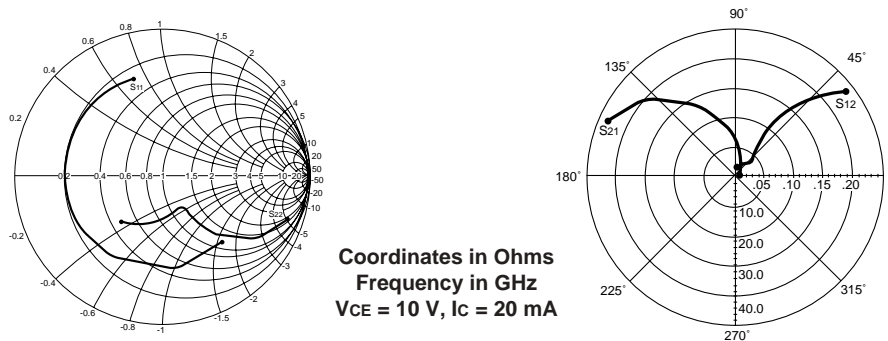

NE85635

VCE = 10 V, IC = 7 mA

FREQUENCY (MHz)	S11		S21		S12		S22		K	MAG ¹ (dB)
	MAG	ANG	MAG	ANG	MAG	ANG	MAG	ANG		
100	.796	-46.7	17.619	152.2	.024	65.5	.907	-19.8	0.11	28.6
500	.709	-139.8	8.012	100.9	.052	32.0	.492	-44.0	0.41	21.9
1000	.700	-170.2	4.276	78.7	.058	30.4	.396	-50.7	0.75	18.7
1500	.692	174.0	2.903	64.1	.064	35.2	.382	-59.8	1.03	15.5
2000	.707	162.6	2.218	51.3	.074	40.7	.392	-70.7	1.10	12.9
2500	.711	152.2	1.800	39.6	.086	44.7	.411	-81.9	1.12	11.1
3000	.715	142.8	1.501	28.8	.103	47.0	.434	-92.9	1.09	9.8
3500	.715	133.8	1.291	18.8	.122	47.4	.462	-103.5	1.03	9.2
4000	.722	125.2	1.140	9.6	.144	46.1	.488	-113.7	0.94	9.0

VCE = 10 V, IC = 20 mA

100	.631	-81.7	33.116	138.8	.018	57.6	.765	-33.5	0.19	32.6
500	.667	-162.2	10.351	93.1	.033	42.9	.306	-54.1	0.70	24.9
1000	.673	177.8	5.308	75.8	.047	50.8	.244	-58.5	0.99	20.5
1500	.668	165.9	3.579	63.3	.063	54.7	.241	-67.1	1.12	15.5
2000	.681	156.6	2.732	52.0	.081	55.4	.256	-77.7	1.08	13.5
2500	.684	147.5	2.217	41.3	.100	54.3	.277	-88.2	1.06	11.9
3000	.686	139.0	1.858	31.1	.120	52.2	.302	-98.2	1.04	10.7
3500	.687	130.8	1.605	21.6	.141	49.2	.331	-107.7	1.00	10.6
4000	.693	122.8	1.426	12.5	.163	45.6	.359	-116.8	0.94	9.4

VCE = 10 V, IC = 30 mA

100	.585	-98.0	38.344	133.3	.016	54.5	.702	-38.2	0.25	33.8
500	.662	-167.8	10.800	91.0	.029	48.8	.263	-55.7	0.81	25.6
1000	.669	175.0	5.500	74.9	.046	56.8	.213	-59.8	1.04	19.6
1500	.665	164.0	3.705	62.9	.064	59.1	.213	-68.5	1.12	15.6
2000	.677	155.1	2.828	51.8	.083	58.5	.230	-79.1	1.08	13.6
2500	.679	146.5	2.294	41.3	.103	56.2	.252	-89.5	1.06	12.0
3000	.682	138.1	1.922	31.3	.124	53.4	.277	-99.4	1.02	10.9
3500	.684	130.0	1.663	21.8	.145	49.9	.306	-108.5	0.99	10.6
4000	.688	122.2	1.478	12.8	.166	45.9	.334	-117.4	0.94	9.5

Note:

1. Gain Calculations:

$$\text{MAG} = \frac{|S_{21}|}{|S_{12}|} (K \pm \sqrt{K^2 - 1})$$

When $K \leq 1$, MAG is undefined and MSG values are used. $\text{MSG} = \frac{|S_{21}|}{|S_{12}|}$, $K = \frac{1 + |\Delta|^2 - |S_{11}|^2 - |S_{22}|^2}{2 |S_{12} S_{21}|}$, $\Delta = S_{11} S_{22} - S_{21} S_{12}$

MAG = Maximum Available Gain

MSG = Maximum Stable Gain

TYPICAL COMMON EMITTER SCATTERING PARAMETERS (T_A = 25°C)

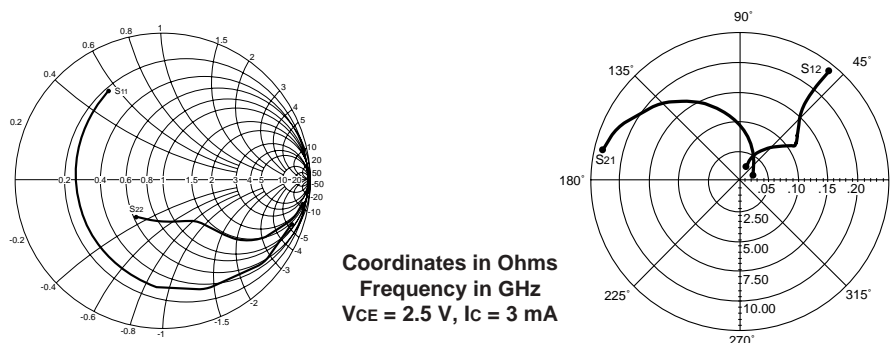

NE85639

VCE = 2.5 V, IC = 1 mA

FREQUENCY (MHz)	S11		S21		S12		S22		K	MAG ¹ (dB)
	MAG	ANG	MAG	ANG	MAG	ANG	MAG	ANG		
100	.968	-27	3.616	164.2	.049	74.5	.985	-8.1	0.03	18.7
500	.785	-103	2.420	110.9	.146	35.4	.769	-29.3	0.31	12.2
1000	.712	-156	1.493	76.0	.150	16.3	.625	-40.9	0.63	10.0
1500	.716	172	1.059	53.7	.122	15.3	.573	-54.4	1.06	7.9
2000	.739	150	0.829	37.9	.107	36.7	.549	-72.6	1.43	5.0
2500	.775	134	0.659	26.6	.146	57.1	.537	-94.8	1.23	3.7
3000	.793	122	0.553	20.6	.215	61.1	.546	-118.5	1.07	2.5

VCE = 2.5 V, IC = 3 mA

100	.888	-39	9.537	156.1	.046	65.8	.935	-16.4	0.14	23.2
500	.628	-127	4.650	101.3	.104	36.1	.523	-42.8	0.50	16.5
1000	.594	-173	2.549	74.3	.117	34.3	.368	-49.8	0.90	13.4
1500	.615	162	1.767	56.3	.133	40.7	.310	-60.9	1.12	9.1
2000	.649	145	1.361	41.8	.159	48.4	.283	-79.4	1.17	6.8
2500	.686	132	1.112	29.9	.199	50.9	.276	-102.9	1.10	5.5
3000	.716	121	0.930	20.7	.245	50.4	.304	-127.4	1.04	4.6

VCE = 10 V, IC = 7 mA

100	.759	-43	16.992	148	.004	54	.896	-18	0.73	36.3
500	.478	-138	6.930	98	.051	51	.496	-29	0.83	21.3
1000	.459	178	3.728	75	.081	57	.398	-31	1.07	15.0
1500	.490	155	2.557	61	.119	61	.353	-39	1.07	11.7
2000	.512	139	1.951	49	.160	63	.326	-47	1.06	9.4
2500	.563	127	1.597	38	.203	62	.293	-63	0.99	9.0
3000	.604	117	1.354	26	.246	57	.275	-84	0.94	7.4
3500	.651	108	1.164	18	.290	52	.279	-109	0.90	6.0
4000	.692	101	1.036	11	.334	49	.316	-129	0.84	4.9

VCE = 10 V, IC = 20 mA

100	.57	-66	28.21	134	.00	46	.75	-28	1.72	34.7
500	.39	-161	8.30	91	.04	64	.36	-28	1.12	20.9
1000	.40	166	4.29	72	.09	67	.30	-28	1.10	15.0
1400	.44	150	3.10	62	.12	66	.27	-36	1.07	12.4
2000	.46	134	2.24	50	.18	64	.23	-46	1.02	9.9
2500	.52	124	1.83	40	.22	60	.19	-64	0.99	9.1
3000	.56	115	1.55	27	.26	54	.17	-92	0.97	7.6
3500	.61	108	1.34	20	.30	48	.18	-123	0.94	6.4
4000	.65	100	1.20	13	.34	46	.23	-143	0.90	5.4

Note:

1. Gain Calculations:

$$MAG = \frac{|S_{21}|}{|S_{12}|} (K \pm \sqrt{K^2 - 1})$$

When $K \leq 1$, MAG is undefined and MSG values are used. $MSG = \frac{|S_{21}|}{|S_{12}|}$, $K = \frac{1 + |\Delta|^2 - |S_{11}|^2 - |S_{22}|^2}{2 |S_{12} S_{21}|}$, $\Delta = S_{11} S_{22} - S_{21} S_{12}$

MAG = Maximum Available Gain

MSG = Maximum Stable Gain

NE85618 NONLINEAR MODEL

SCHEMATIC

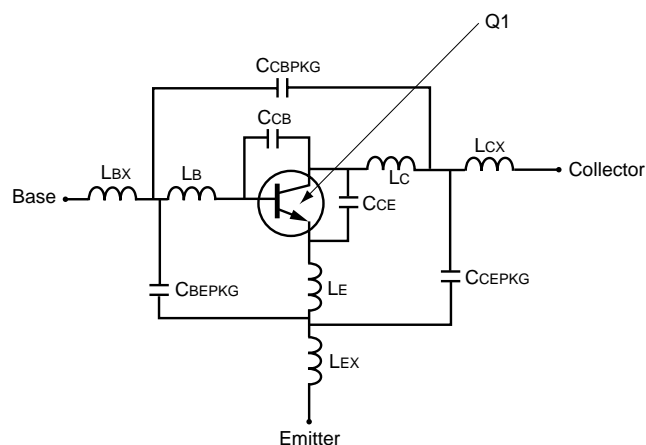

BJT NONLINEAR MODEL PARAMETERS(1)

Parameters	Q1	Parameters	Q1
IS	6e-16	MJC	0.55
BF	120	XCJC	0.3
NF	0.98	CJS	0
VAF	10	VJS	0.75
IKF	0.08	MJS	0
ISE	3.2e-15	FC	0.5
NE	1.93	TF	10e-12
BR	12	XTF	6
NR	0.991	VTF	10
VAR	3.9	ITF	0.2
IKR	0.17	PTF	0
ISC	0	TR	1e-9
NC	2	EG	1.11
RE	0.38	XTB	0
RB	4.16	XTI	3
RBM	3.6	KF	0
IRB	1.96e-4	AF	1
RC	2		
CJE	2.8e-12		
VJE	1.3		
MJE	0.5		
CJC	1.1e-12		
VJC	0.7		

(1) Gummel-Poon Model

UNITS

Parameter	Units
time	seconds
capacitance	farads
inductance	henries
resistance	ohms
voltage	volts
current	amps

ADDITIONAL PARAMETERS

Parameters	NE85618
CCB	0.087e-12
CCE	0.16e-12
LB	1.29e-9
LC	1.04e-9
LE	0.62e-9
CCBPKG	0.054e-12
CCEPKG	0.044e-12
CBEPKG	0.33e-12
LBX	0.18e-9
LCX	0.41e-9
LEX	0.09e-9

MODEL RANGE

Frequency: 0.05 to 5.0 GHz
 Bias: VCE = 2.5 V to 10 V, IC = 3 mA to 10 mA
 Date: 6/7/96

Note:

This nonlinear model utilized the latest data available. See our Design Parameter Library at www.cel.com for this data.

NE856 SERIES

NE85619 NONLINEAR MODEL

SCHEMATIC

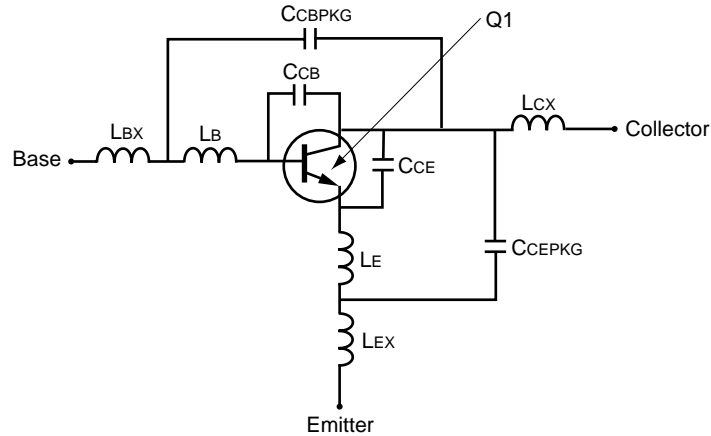

BJT NONLINEAR MODEL PARAMETERS (1)

Parameters	Q1	Parameters	Q1
IS	6e-16	MJC	0.55
BF	120	XCJC	0.3
NF	0.98	CJS	0
VAF	10	VJS	0.75
IKF	0.08	MJS	0
ISE	3.2e-15	FC	0.5
NE	1.93	TF	10e-12
BR	12	XTF	6
NR	0.991	VTF	10
VAR	3.9	ITF	0.2
IKR	0.17	PTF	0
ISC	0	TR	1e-9
NC	2	EG	1.11
RE	0.38	XTB	0
RB	4.16	XTI	3
RBM	3.6	KF	0
IRB	1.96e-4	AF	1
RC	2		
CJE	2.8e-12		
VJE	1.3		
MJE	0.5		
CJC	1.1e-12		
VJC	0.7		

(1) Gummel-Poon Model

UNITS

Parameter	Units
time	seconds
capacitance	farads
inductance	henries
resistance	ohms
voltage	volts
current	amps

ADDITIONAL PARAMETERS

Parameters	NE85619
CCB	0.087e-12
CCE	0.16e-12
LB	1.84e-9
LE	0.56e-9
CCBPKG	0.08e-12
CCEPKG	0.39e-12
LBX	0.19e-9
LCX	0.19e-9
LEX	0.19e-9

MODEL RANGE

Frequency: 0.05 to 3.0 GHz
 Bias: $V_{CE} = 2.5 \text{ V to } 10 \text{ V}$, $I_c = 0.3 \text{ mA to } 10 \text{ mA}$

Note:

This nonlinear model utilized the latest data available. See our Design Parameter Library at www.cel.com for this data.

NE85630 NONLINEAR MODEL

SCHEMATIC

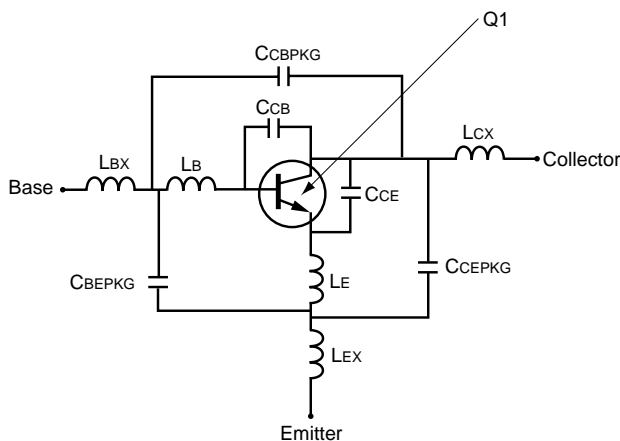

BJT NONLINEAR MODEL PARAMETERS (1)

Parameters	Q1	Parameters	Q1
IS	6e-16	MJC	0.55
BF	120	XCJC	0.3
NF	0.98	CJS	0
VAF	10	VJS	0.75
IKF	0.08	MJS	0
ISE	32e-16	FC	0.5
NE	1.93	TF	10e-12
BR	12	XTF	6
NR	0.991	VTF	10
VAR	3.9	ITF	0.2
IKR	0.17	PTF	0
ISC	0	TR	1e-9
NC	2	EG	1.11
RE	0.38	XTB	0
RB	4.16	XTI	3
RBM	3.6	KF	0
IRB	1.96e-4	AF	1
RC	2		
CJE	2.8e-12		
VJE	1.3		
MJE	0.5		
CJC	1.1e-12		
VJC	0.7		

(1) Gummel-Poon Model

UNITS

Parameter	Units
time	seconds
capacitance	farads
inductance	henries
resistance	ohms
voltage	volts
current	amps

ADDITIONAL PARAMETERS

Parameters	NE85630
CCB	0.09e-12
CCE	0.16e-12
LB	1.4e-9
LE	0.93e-9
CCBPKG	0.12e-12
CCEPKG	0.16e-12
CBEPKG	0.04e-12
LBX	0.2e-9
LCX	0.2e-9
LEX	0.2e-9

MODEL RANGE

Frequency: 0.05 to 3.0 GHz
 Bias: $V_{CE} = 2.5\text{ V to }10\text{ V}$, $I_C = 0.3\text{ mA to }10\text{ mA}$
 Date: 10/25/96

Note:

This nonlinear model utilized the latest data available. See our Design Parameter Library at www.cel.com for this data.

NE856 SERIES

NE85633 NONLINEAR MODEL

SCHEMATIC

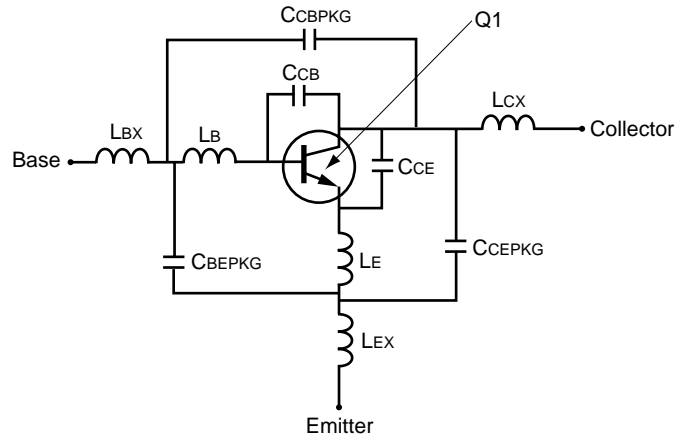

BJT NONLINEAR MODEL PARAMETERS ⁽¹⁾

Parameters	Q1	Parameters	Q1
IS	6e-16	MJC	0.55
BF	120	XCJC	0.3
NF	0.98	CJS	0
VAF	10	VJS	0.75
IKF	0.08	MJS	0
ISE	32e-16	FC	0.5
NE	1.93	TF	15e-12
BR	12	XTF	6
NR	0.991	VTF	10
VAR	3.9	ITF	0.2
IKR	0.17	PTF	0
ISC	0	TR	1e-9
NC	2	EG	1.11
RE	0.38	XTB	0
RB	4.16	XTI	3
RBM	3.6	KF	1.56e-18
IRB	1.96e-4	AF	1.49
RC	2		
CJE	2.8e-12		
VJE	1.3		
MJE	0.5		
CJC	1.1e-12		
VJC	0.7		

(1) Gummel-Poon Model

UNITS

Parameter	Units
time	seconds
capacitance	farads
inductance	henries
resistance	ohms
voltage	volts
current	amps

ADDITIONAL PARAMETERS

Parameters	NE85633
CCB	0.09e-12
CCE	0.16e-12
LB	0.85e-9
LE	1e-9
CCBPKG	0.15e-12
CCEPKG	0.15e-12
CBEPKG	0.07e-12
LBX	0.3e-9
LCX	0.4e-9
LEX	0.3e-9

MODEL RANGE

Frequency: 0.1 to 8.0 GHz

Bias: $V_{CE} = 1\text{ V to }10\text{ V}$, $I_C = 1\text{ mA to }20\text{ mA}$

Date: 7/97

Note:

This nonlinear model utilized the latest data available. See our Design Parameter Library at www.cel.com for this data.

NE85635 NONLINEAR MODEL

SCHEMATIC

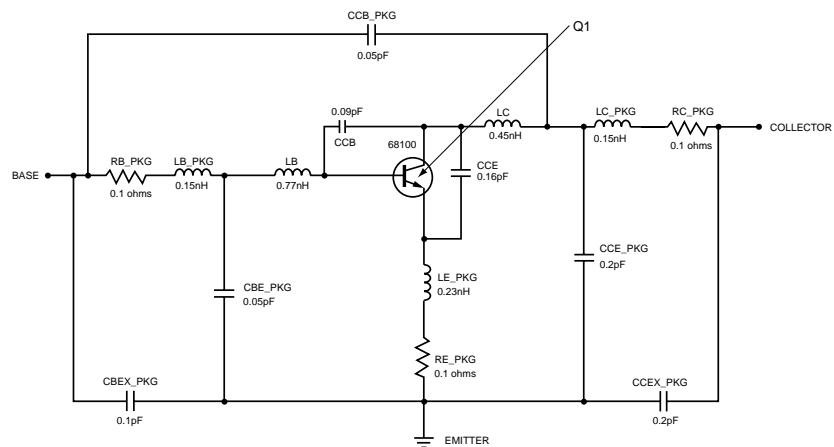

BJT NONLINEAR MODEL PARAMETERS (1)

Parameters	Q1	Parameters	Q1
IS	6e-16	MJC	0.55
BF	120	XCJC	0.3
NF	0.98	CJS	0
VAF	10	VJS	0.75
IKF	0.08	MJS	0
ISE	32e-16	FC	0.5
NE	1.93	TF	10e-12
BR	12	XTF	6
NR	0.991	VTF	10
VAR	3.9	ITF	0.2
IKR	0.17	PTF	0
ISC	0	TR	1e-9
NC	2	EG	1.11
RE	0.38	XTB	0
RB	4.16	XTI	3
RBM	3.6	KF	0
IRB	1.96e-4	AF	1
RC	2		
CJE	2.8e-12		
VJE	1.3		
MJE	0.5		
CJC	1.1e-12		
VJC	0.7		

UNITS

Parameter	Units
time	seconds
capacitance	farads
inductance	henries
resistance	ohms
voltage	volts
current	amps

MODEL RANGE

Frequency: 0.05 to 5.0 GHz
 Bias: VCE = 10 V, Ic = 7 mA to 30 mA
 Date: 11/1/96

(1) Gummel-Poon Model

NE856 SERIES

NE85639 NONLINEAR MODEL

SCHEMATIC

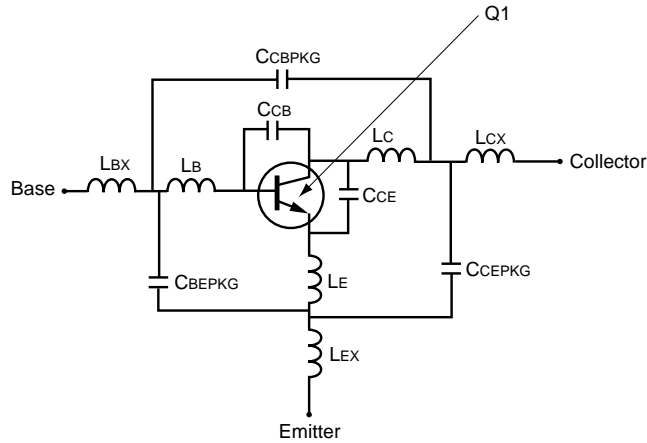

BJT NONLINEAR MODEL PARAMETERS (1)

Parameters	Q1	Parameters	Q1
IS	6e-16	MJC	0.55
BF	120	XCJC	0.3
NF	0.98	CJS	0
VAF	10	VJS	0.75
IKF	0.08	MJS	0
ISE	3.2e-15	FC	0.5
NE	1.93	TF	10e-12
BR	12	XTF	6
NR	0.991	VTF	10
VAR	3.9	ITF	0.2
IKR	0.17	PTF	0
ISC	0	TR	1e-9
NC	2	EG	1.11
RE	0.38	XTB	0
RB	4.16	XTI	3
RBM	3.6	KF	0
IRB	1.96e-4	AF	1
RC	2		
CJE	2.8e-12		
VJE	1.3		
MJE	0.5		
CJC	1.1e-12		
VJC	0.7		

(1) Gummel-Poon Model

UNITS

Parameter	Units
time	seconds
capacitance	farads
inductance	henries
resistance	ohms
voltage	volts
current	amps

ADDITIONAL PARAMETERS

Parameters	NE85639
CCB	0.087e-12
CCE	0.16e-12
LB	1.1e-9
LC	0.81e-9
LE	0.58e-9
CCBPKG	0.02e-12
CCEPKG	0.08e-12
CBEPKG	0.01e-12
LBX	0.39e-9
LCX	0.39e-9
LEX	0.2e-9

MODEL RANGE

Frequency: 0.1 to 3.0 GHz
 Bias: $V_{CE} = 2.5 \text{ V to } 10 \text{ V}$, $I_c = 0.3 \text{ mA to } 7 \text{ mA}$
 Date: 6/12/96

Note:

This nonlinear model utilized the latest data available. See our Design Parameter Library at www.cel.com for this data.

NE856 SERIES

OUTLINE DIMENSIONS (Units in mm)

NE85600 (CHIP)

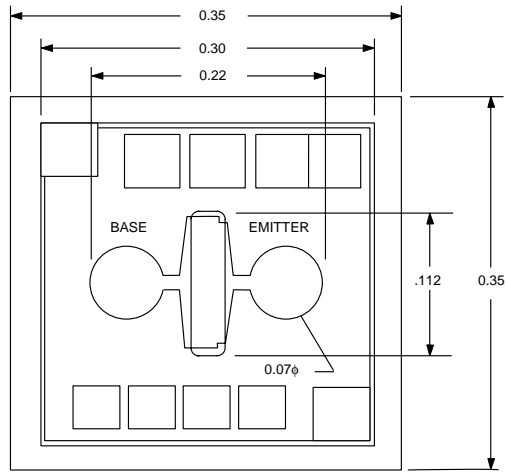

(Chip Thickness: 140 to 160 μm)

PACKAGE OUTLINE 18 (SOT-343)

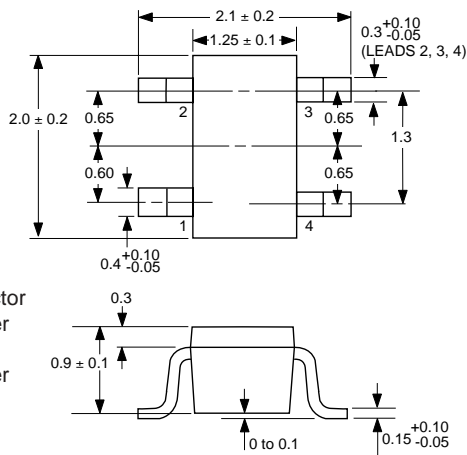

- 1. Collector
- 2. Emitter
- 3. Base
- 4. Emitter

PACKAGE OUTLINE 18 RECOMMENDED P.C.B. LAYOUT

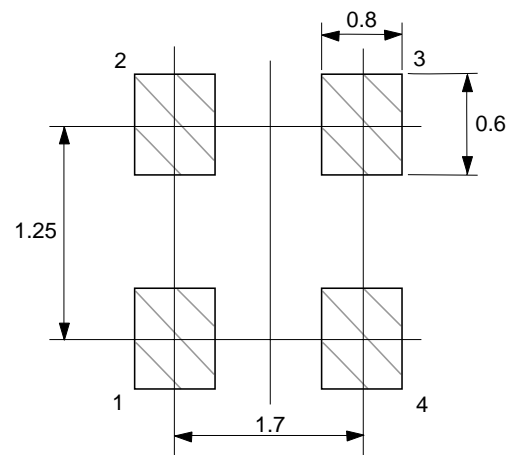

PACKAGE OUTLINE 19

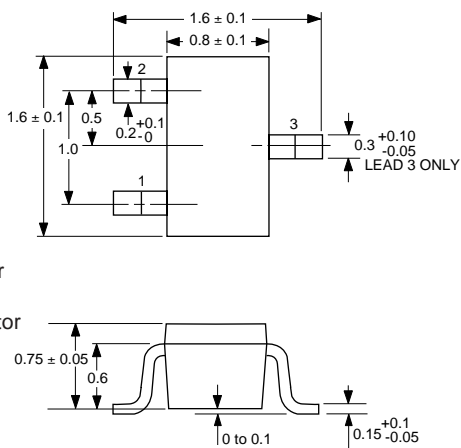

- 1. Emitter
- 2. Base
- 3. Collector

PACKAGE OUTLINE 19 RECOMMENDED P.C.B. LAYOUT

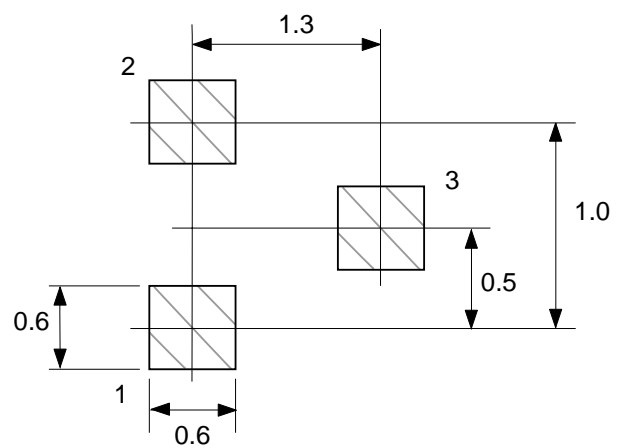

OUTLINE DIMENSIONS (Units in mm)

**PACKAGE OUTLINE 30
(SOT-323)**

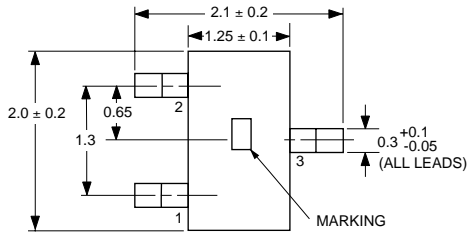

- 1. Emitter
- 2. Base
- 3. Collector

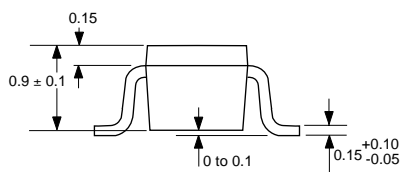

**PACKAGE OUTLINE 30
RECOMMENDED P.C.B. LAYOUT**

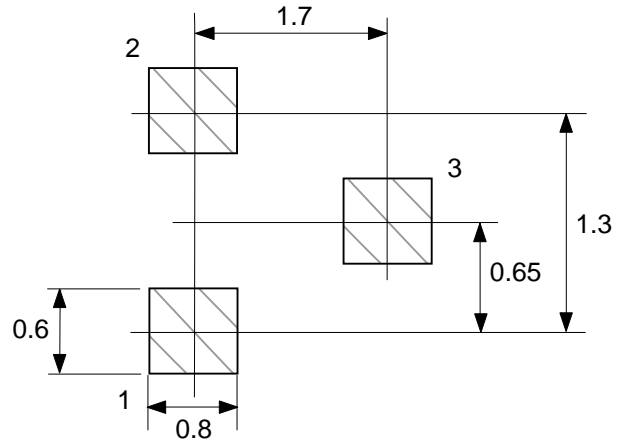

**PACKAGE OUTLINE 32
(TO-92)**

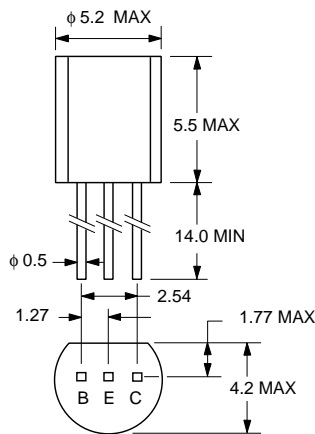

**PACKAGE OUTLINE 34
(SOT-89)**

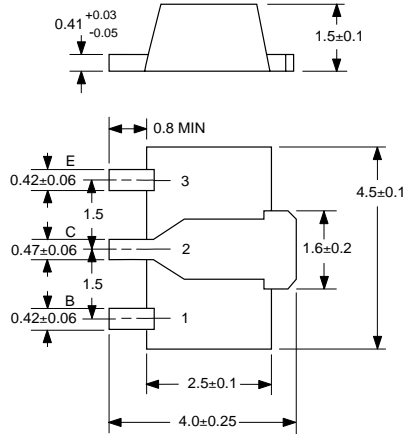

**PACKAGE OUTLINE 33
(SOT-23)**

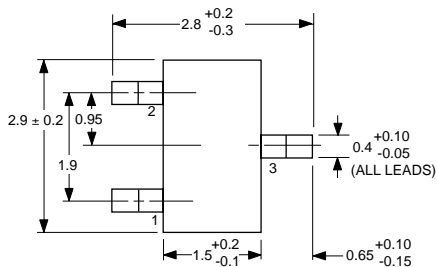

- 1. Emitter
- 2. Base
- 3. Collector

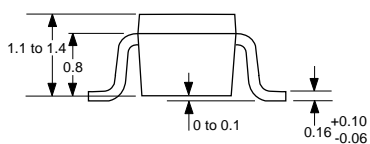

**PACKAGE OUTLINE 33
RECOMMENDED P.C.B. LAYOUT**

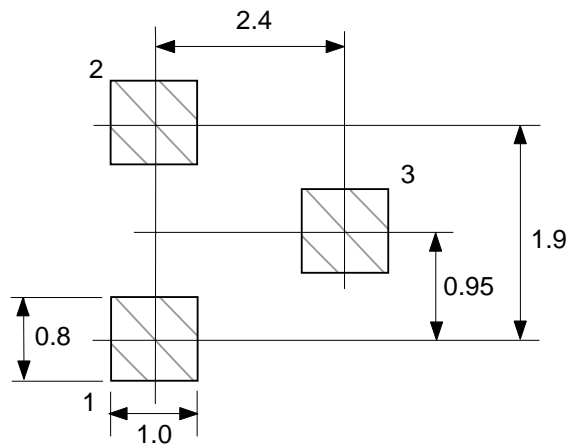

NE556 SERIES

OUTLINE DIMENSIONS (Units in mm)

**PACKAGE OUTLINE 35
(MICRO-X)**

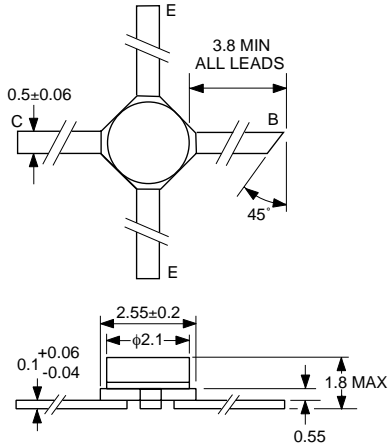

PACKAGE OUTLINE 39

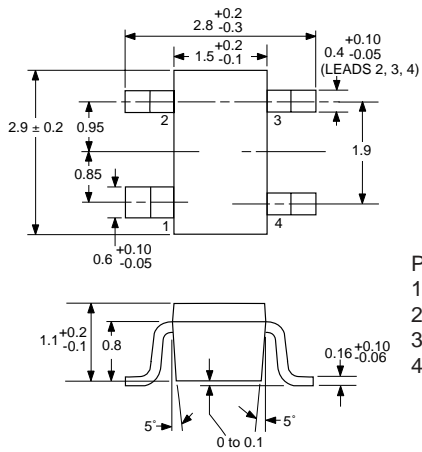

- PIN CONNECTIONS**
1. Collector
 2. Emitter
 3. Base
 4. Emitter

**PACKAGE OUTLINE 39
RECOMMENDED P.C.B. LAYOUT**

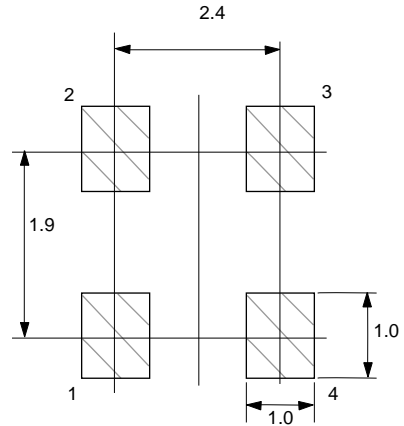

PACKAGE OUTLINE 39R

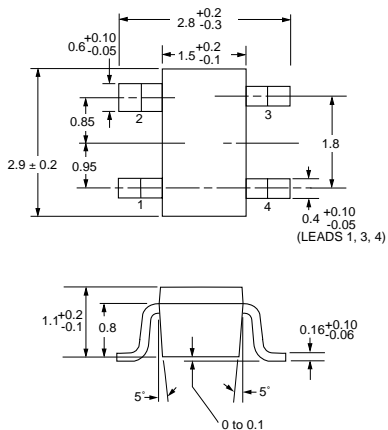

- PIN CONNECTIONS**
1. Emitter
 2. Collector
 3. Emitter
 4. Base

**PACKAGE OUTLINE 39R
RECOMMENDED P.C.B. LAYOUT**

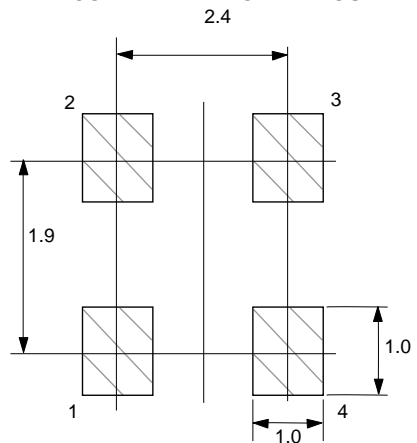

ORDERING INFORMATION

PART NUMBER	QUANTITY	PACKAGING
NE85600	100	Waffle Pack
NE85618-T1	3000	Tape/Reel
NE85619-T1	3000	Tape/Reel
NE85630-T1	3000	Tape/Reel
NE85632	1	ESD Bag
NE85633-T1B	3000	Tape/Reel
NE85634-T1	1000	Tape/Reel
NE85635	1	ESD Bag
NE85639-T1	3000	Tape/Reel
NE85639R-T1	3000	Tape/Reel

Note:

1. Embossed tape 12 mm wide.

Life Support Applications

These NEC products are not intended for use in life support devices, appliances, or systems where the malfunction of these products can reasonably be expected to result in personal injury. The customers of CEL using or selling these products for use in such applications do so at their own risk and agree to fully indemnify CEL for all damages resulting from such improper use or sale.