



# MEDIUM POWER AMPLIFIER GaAs MMIC

## ■GENERAL DESCRIPTION

NJG1301V is a medium power amplifier which is designed for use of output stage of Japanese PHS and digital wireless phone.

NJG1301V features low operating voltage, high efficiency, and comes with, internal input and output matching circuit and very small SSOP package. This amplifier is operated up to 21dBm output level with very low noise generation.

## ■PACKAGE OUTLINE

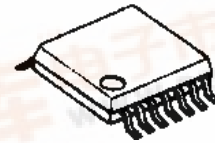

NJG1301V

## ■FEATURES

- Low operating voltage +3.0V typ.
- Low current consumption 185mA typ. @f=1.9GHz, P<sub>out</sub>=21dBm
- Low distortion (ACP) -60dBc typ. @f=1.9GHz, P<sub>out</sub>=21dBm
- Reduction of redact parasitic oscillation
- Input and output internal matching circuits
- Package SSOP14

## ■PIN CONFIGURATION

V Type  
(Top View)

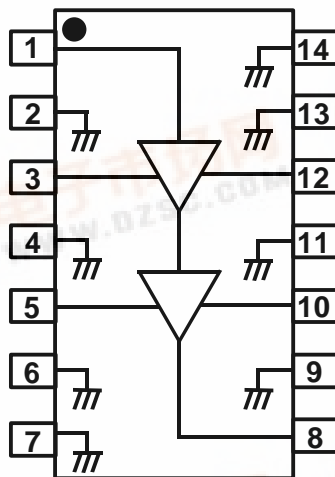

### Pin connection

- |                    |                     |
|--------------------|---------------------|
| 1.RF <sub>in</sub> | 8.RF <sub>out</sub> |
| 2.GND              | 9.GND               |
| 3.V <sub>GG1</sub> | 10.V <sub>DD2</sub> |
| 4.GND              | 11.GND              |
| 5.V <sub>GG2</sub> | 12.V <sub>DD1</sub> |
| 6.GND              | 13.GND              |
| 7.GND              | 14.GND              |



# NJG1301V

## ■ABSOLUTE MAXIMUM RATINGS

( $T_a=+25^{\circ}\text{C}$ ,  $Z_s=Z_i=50\Omega$ )

PARAMETER	SYMBOL	CONDITIONS	RATINGS	UNITS
Drain Voltage	$V_{DD1}, V_{DD2}$	$V_{GG1}, V_{GG2} = -0.9\text{V}$	6	V
Gate Voltage	$V_{GG1}, V_{GG2}$	$V_{DD1}, V_{DD2} = -3.0\text{V}$	-4	V
Input Power	$P_{in}$	$V_{DD1}, V_{DD2} = -3.0\text{V}$ , $V_{GG1}, V_{GG2} = -0.9\text{V}$	10	dBm
Power Dissipation	$P_D$	At on PCB board	600	mW
Operating Temperature	$T_{opr}$		-30~+85	$^{\circ}\text{C}$
Storage Temperature	$T_{stg}$		-40~+150	$^{\circ}\text{C}$

## ■ELECTRICAL CHARACTERISTICS

( $T_a=25^{\circ}\text{C}$ ,  $Z_s=Z_i=50\Omega$ )

PARAMETER	SYMBOL	CONDITIONS	MIN	TYP	MAX	UNITS
Operating Freq.	freq	$V_{DD1,2}=3.0\text{V}$	1.89	-	1.92	GHz
Drain Voltage	$V_{DD1,2}$		2.9	3.0	5.0	V
Gate Voltage	$V_{GG1,2}$	$V_{DD1,2}=3.0\text{V}$ , $I_{idle}=170\text{mA}$	-1.25	-0.9	-0.6	V
Idle Current *1	$I_{idle}$	$V_{DD1,2}=3.0\text{V}$ , RF No signal	165	170	175	mA
Operating Current *1	$I_{DD}$	$V_{DD1,2}=3.0\text{V}$ , $P_{out}=21\text{dBm}$	170	185	195	mA
Gate Current *2	$I_{GG}$	$V_{DD1,2}=3.0\text{V}$ , $P_{out}=21\text{dBm}$	-150	-70	-	$\mu\text{A}$
Small Signal Gain	Gain	$V_{DD1,2}=3.0\text{V}$ , $I_{idle}=170\text{mA}$	20	23	26	dB
Gain Flatness	$G_{flat}$	$V_{DD1,2}=3.0\text{V}$ , $I_{idle}=170\text{mA}$	0	0.5	1.0	dB
Pout at 1dB Gain Compression point	$P_{-1dB}$	$V_{DD1,2}=3.0\text{V}$	21	22	-	dBm
Adjacent Channel Leakage Power 1	$P_{acp1}$	$V_{DD1,2}=3.0\text{V}$ , $P_{out}=21\text{dBm}$ offset=600kHz, $P_{in}$ : $\pi/4$ DQPSK	-	-60	-55	dBc
Adjacent Channel Leakage Power 2	$P_{acp2}$	$V_{DD1,2}=3.0\text{V}$ , $P_{out}=21\text{dBm}$ offset=900kHz, $P_{in}$ : $\pi/4$ DQPSK	-	-65	-60	dBc
Input VSWR	$VSWR_i$	$V_{DD1,2}=3.0\text{V}$	-	-	2.2	
Load VSWR Tolerance	-	$V_{DD1,2}=3.0\text{V}$ , $P_{out}=21\text{dBm}$ Load VSWR=4:1, All phase	Parasitic Osc. vs Fundamental Signal Level -60dBc Max.			

\*1: Total current of  $V_{DD1}$  terminal and  $V_{DD2}$  terminal

\*2: Total current of  $V_{GG1}$  terminal and  $V_{GG2}$  terminal

## TYPICAL CHARACTERISTICS

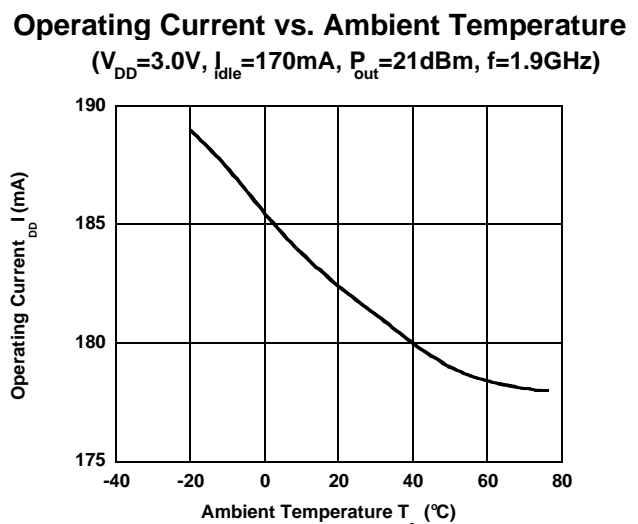
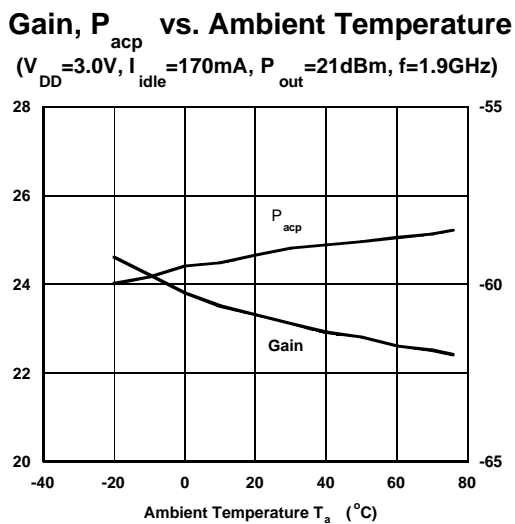
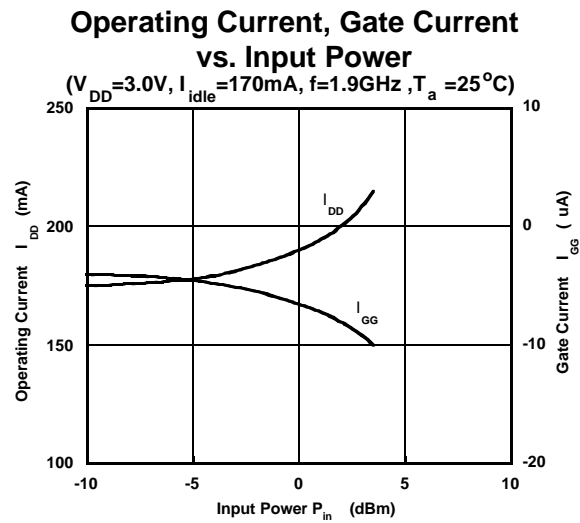
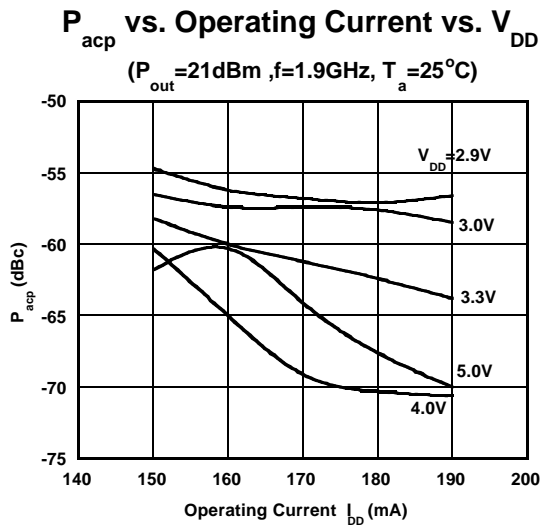
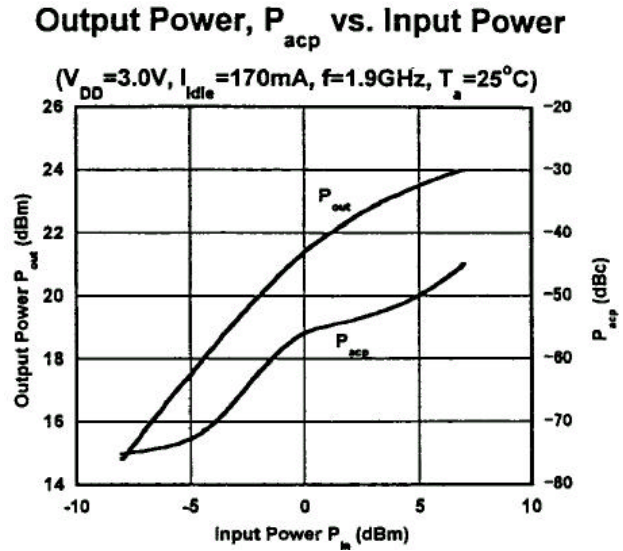
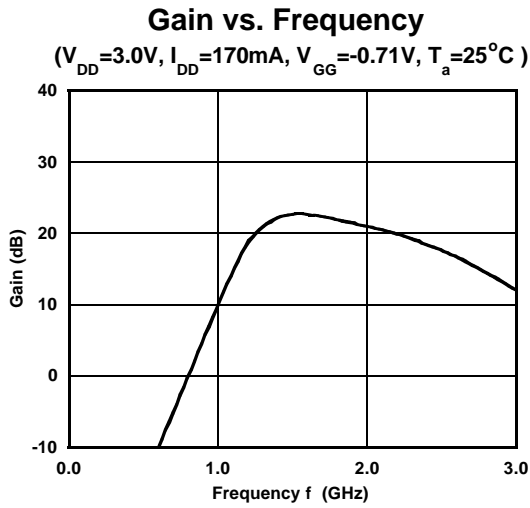

# NJG1301V

## TYPICAL CHARACTERISTICS

### Gain vs. PHS Band Frequency

( $V_{DD}=3.0V, I_{DD}=170mA, V_{GG}=-0.71V, T_a=25^\circ C$ )

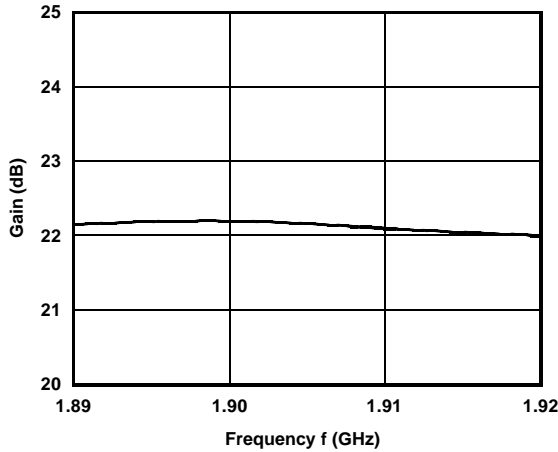

### $|S_{11}|, |S_{22}|$ vs. Frequency

( $V_{DD}=3.0V, I_{DD}=170mA, T_a=25^\circ C$ )

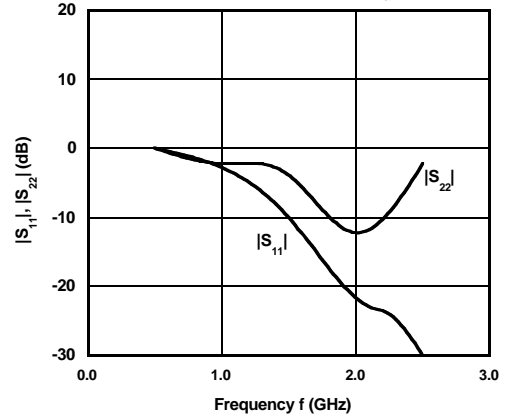

### Output Power, Total Current vs. Input Power

( $V_{DD}=3V, f=1.9GHz, T_a=25^\circ C$ )

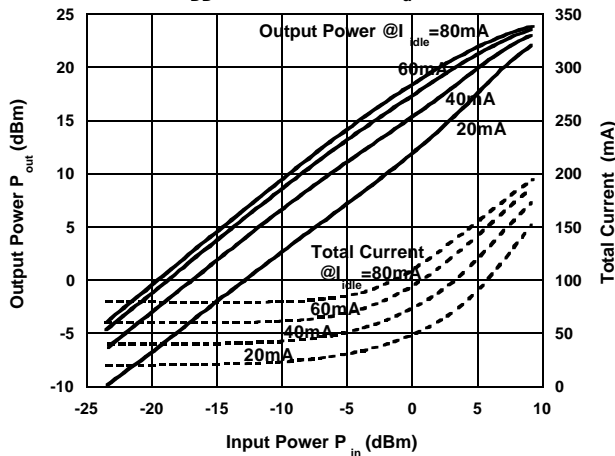

### Output Power, P.A.E. vs. Input Power

( $V_{DD}=3V, f=1.9GHz, T_a=25^\circ C$ )

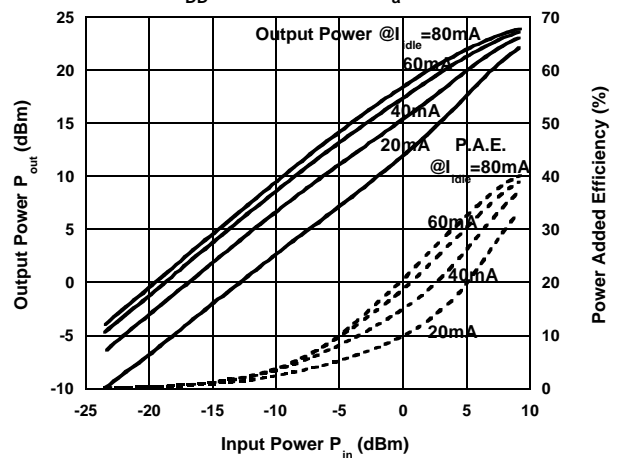

### Output Spectrum

( $V_{DD}=3.0V, I_{dca}=170mA, P_{out}=21dBm, T_a=25^\circ C$ )

ATTEN 10dB

RL 0dBm

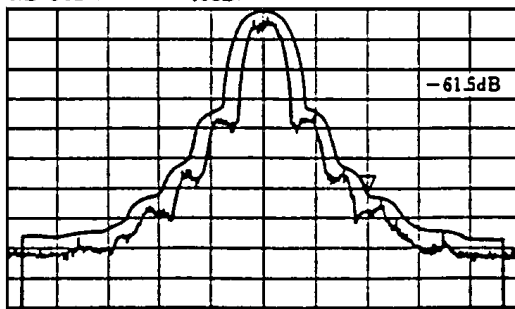

CENTER 1.90000GHz SPAN 3.000MHz  
RBW 1.0kHz VBW 10kHz SWP 10.2sac

### Harmonic Spectrum

(Suppressed Level for Fundamental Signal Level)

( $P_{out}=21dBm, V_{DD}=3.0V, I_{dca}=170mA, T_a=25^\circ C$ )

ATTEN 30dB

RL 20.0dBm

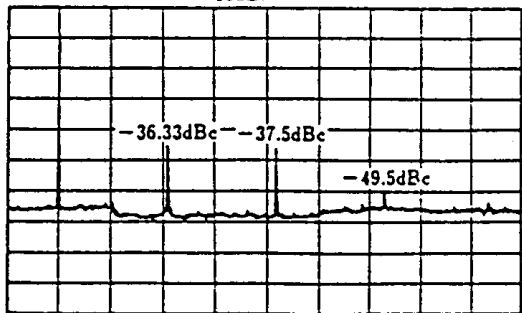

START 1.000GHz STOP 10.000GHz  
RBW 1.0MHz VBW 1.0MHz SWP 180ms

## RECOMMENDED CIRCUIT

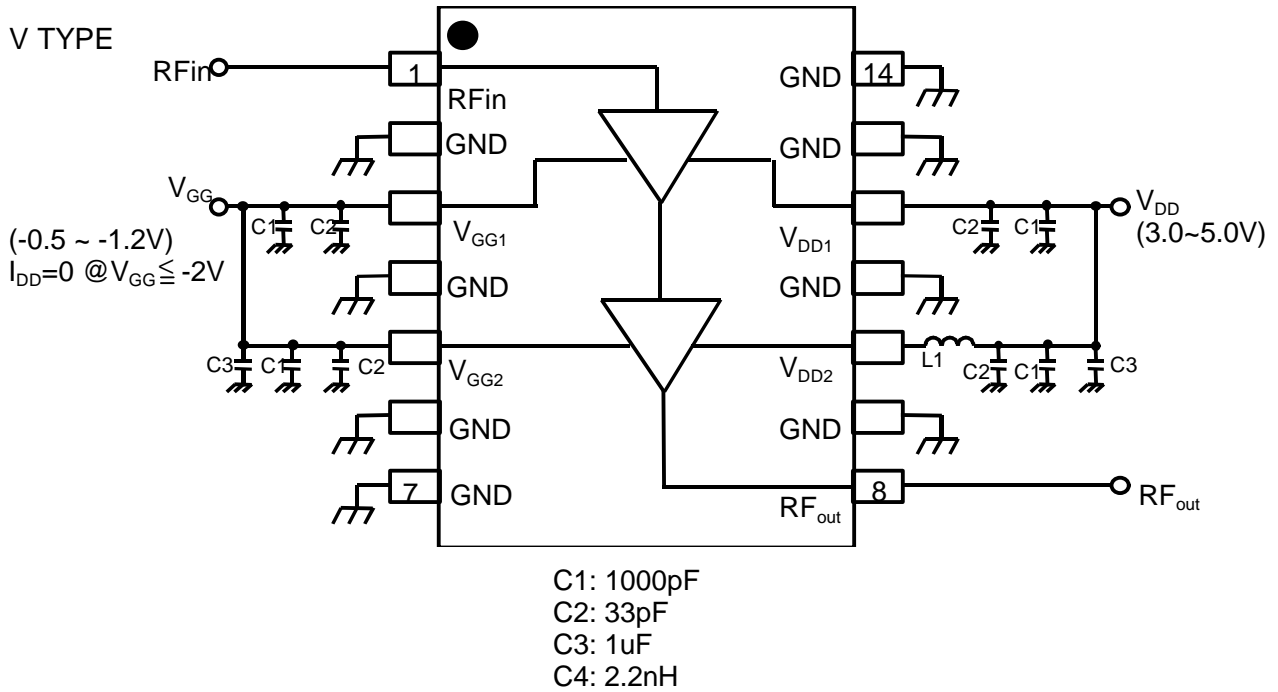

## RECOMMENDED PCB DESIGN

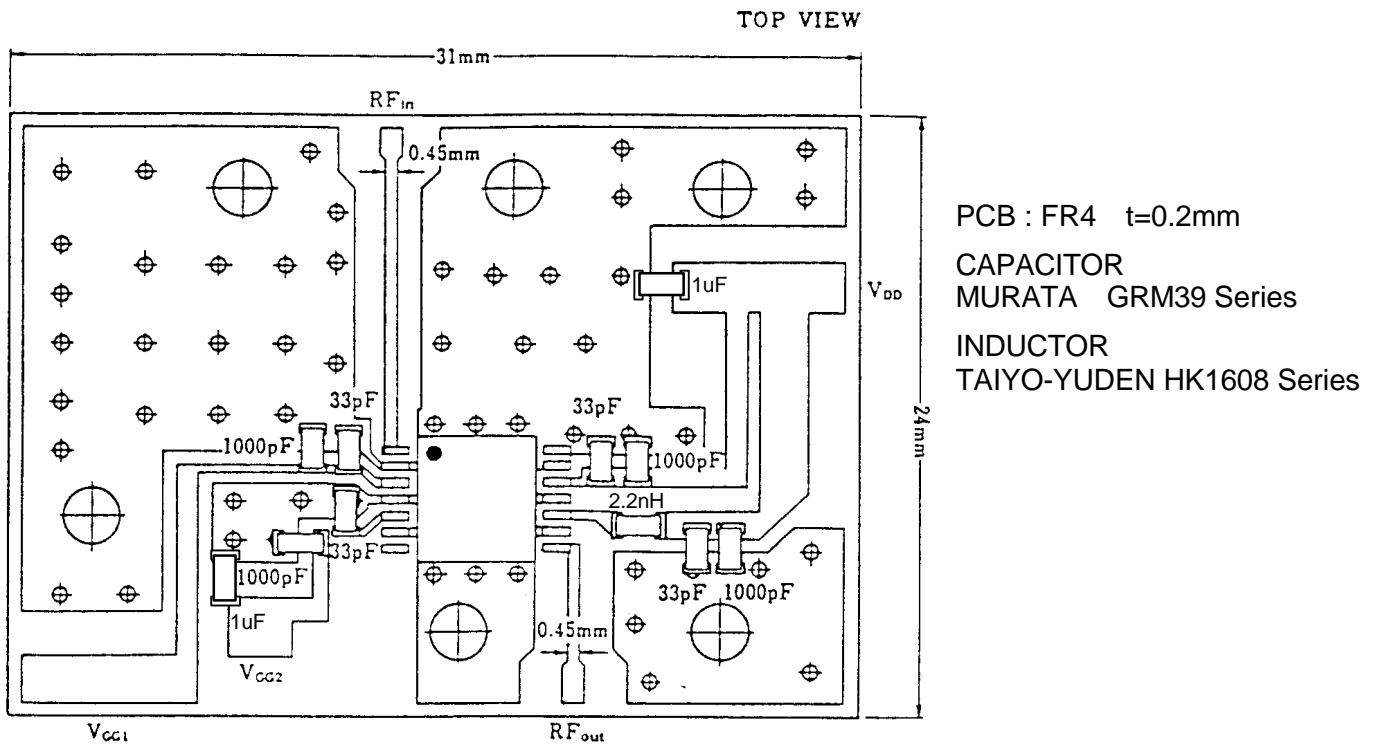

# NJG1301V

## APPLICATION CIRCUIT ( NEGATIVE VOLTAGE GENERATOR)

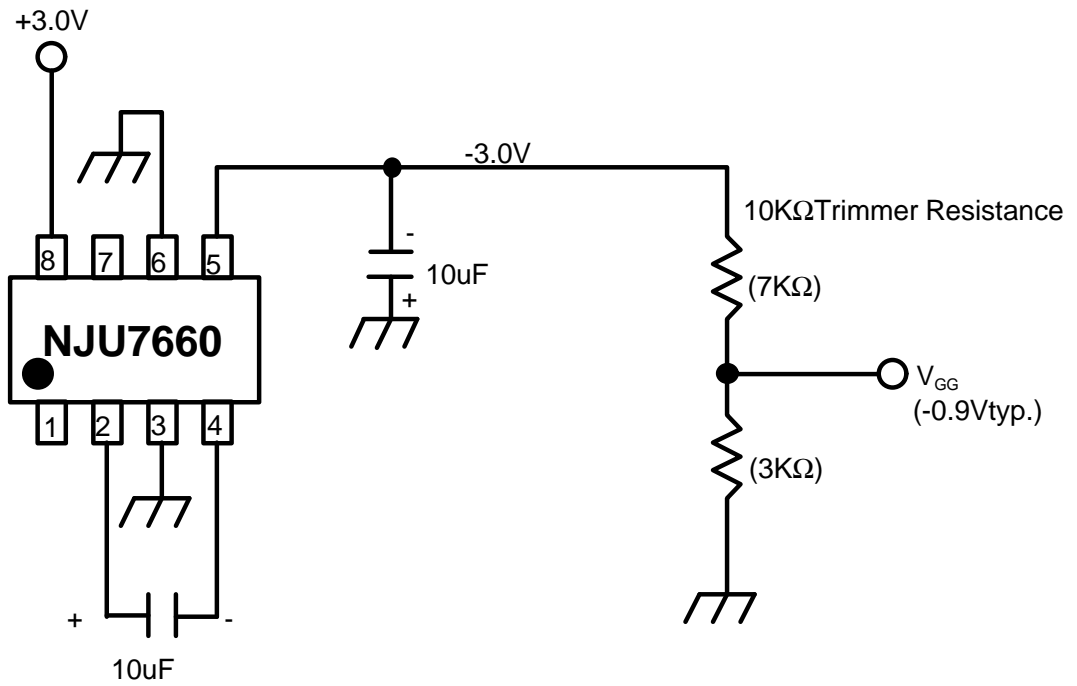

## ■PACKAGE OUTLINE (SSOP14)

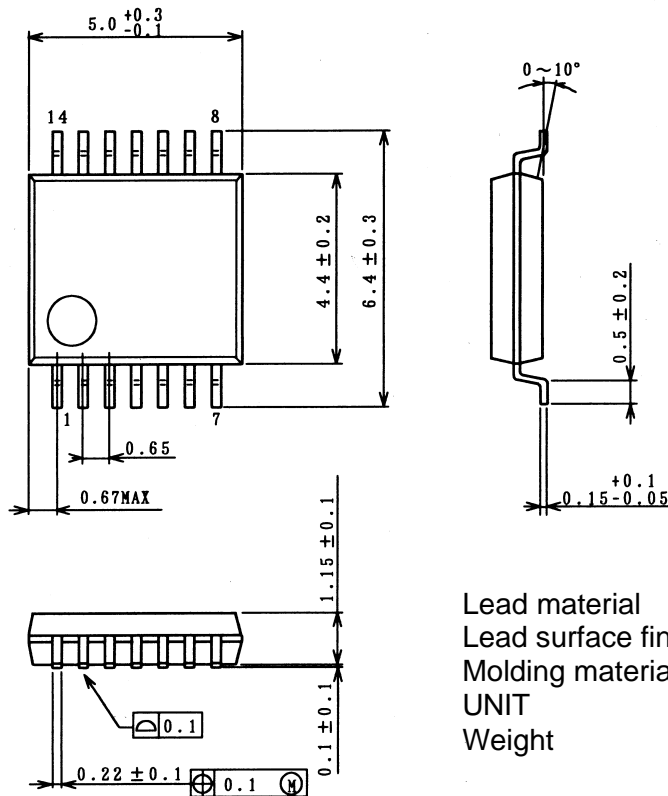

Lead material	: Copper
Lead surface finish	: Solder plating
Molding material	: Epoxy resin
UNIT	: mm
Weight	: 66mg

### Cautions on using this product

This product contains Gallium-Arsenide (GaAs) which is a harmful material.

- Do NOT eat or put into mouth.
- Do NOT dispose in fire or break up this product.
- Do NOT chemically make gas or powder with this product.
- To waste this product, please obey the relating law of your country.

### [CAUTION]

The specifications on this databook are only given for information, without any guarantee as regards either mistakes or omissions. The application circuits in this databook are described only to show representative usages of the product and not intended for the guarantee or permission of any right including the industrial rights.

This product may be damaged with electric static discharge (ESD) or spike voltage. Please handle with care to avoid these damages.