

GENERAL PURPOSE PHOTO REFLECTOR

■ GENERAL DESCRIPTION

The NJL5196K/5197K are super miniature and super thin general purpose photo reflectors, which can be soldering by reflow-method. These are compatible to NJL5181K/5183K in the characteristics, and attain high cost performance.

In order to prevent from degradation of this device in moisturing at reflow method, so that keep the precaution for handling.

■ FEATURES

- Super miniature, super thin type
- Built-in visible light cut-off filter.
- High output, high S/N ratio.

■ APPLICATIONS

- End detector of video, audio tape.
- Rotation detection and control of various motors, audio turntables.
- Paper edge detection and mechanism timing detection of facsimile printer, X-Y recorder.
- Reading film information and mechanism timing detection of camera.
- Reading out the characters of bar code reader, encoder and the automatic vending machine.
- Various detection of industrial system, such as FDD, Robot.

■ ABSOLUTE MAXIMUM RATINGS (Ta=25 °C)

PARAMETER	SYMBOL	RATINGS	UNIT
Emitter			
Forward Current (Continuous)	I_F	30	mA
Reverse Voltage (Continuous)	V_R	6	V
Power Dissipation	P_D	45	mW
Detector			
Collector-Emitter Voltage	V_{CEO}	16	V
Emitter-Collector Voltage	V_{ECO}	6	V
Collector Current	I_C	10	mA
Collector Power Dissipation	P_C	25	mW
Coupled			
Total Power Dissipation	P_{tot}	60	mW
Operating Temperature	T_{opr}	-20~+85	°C
Storage Temperature	T_{stg}	-30~+85	°C
Soldering Temperature	T_{sol}	260 (10sec. 1.5mm from body)	°C

■ ELECTRO-OPTICAL CHARACTERISTICS (Ta=25 °C)

PARAMETER	SYMBOL	TEST CONDITION	MIN.	TYP.	MAX.	UNIT
Emitter						
Forward Voltage	V_F	$I_F=4mA$	—	—	1.4	V
Reverse Current	I_R	$V_R=6V$	—	—	10	μA
Capacitance	C_t	$V_R=0V, f=1MHz$	—	25	—	pF
Detector						
Dark Current	I_{CEO}	$V_{CE}=10V$	—	—	0.2	μA
Collector-Emitter Voltage	V_{CEO}	$I_C=100\mu A$	16	—	—	V
Coupled						
Output Current	I_O	$I_F=4mA, V_{CE}=2V, d=0.7mm$	35	—	—	μA
Operating Dark Current	I_{CEO}	$I_F=4mA, V_{CE}=2V$	—	—	0.2	μA
Rise Time	t_r	$I_O=100\mu A, V_{CE}=2V, RL=1K\Omega, d=0.7mm$	—	30	—	μS
Fall Time	t_f	$I_O=100\mu A, V_{CE}=2V, RL=1K\Omega, d=0.7mm$	—	30	—	μS

■ OUTLINE (typ.) Unit: mm

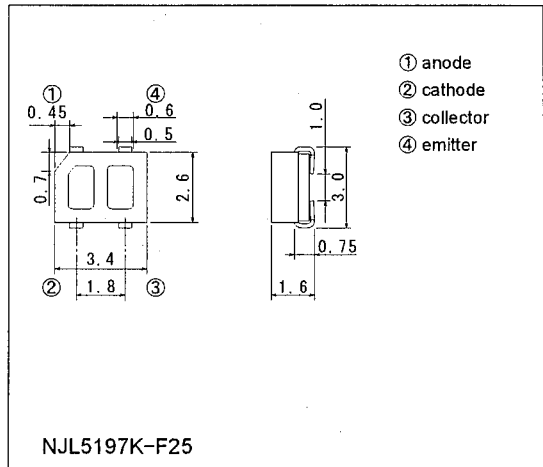
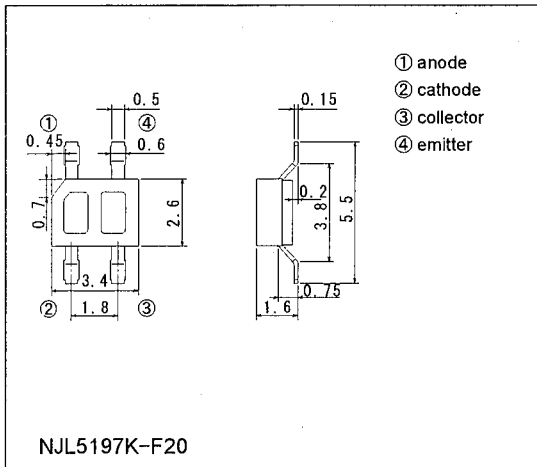
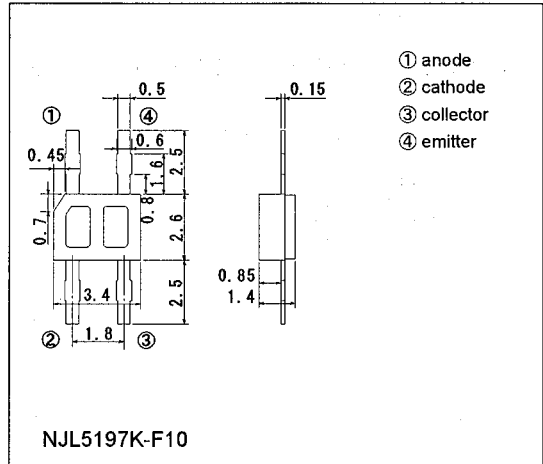
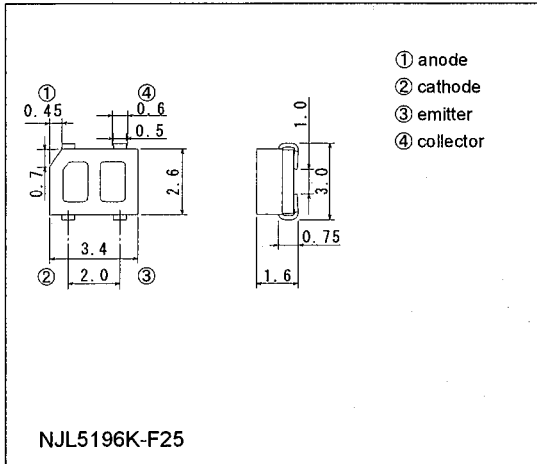
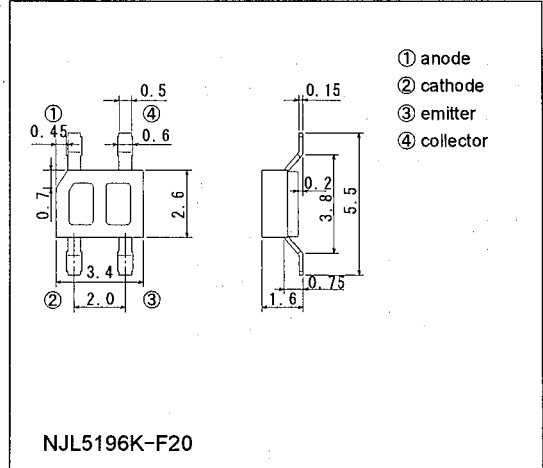
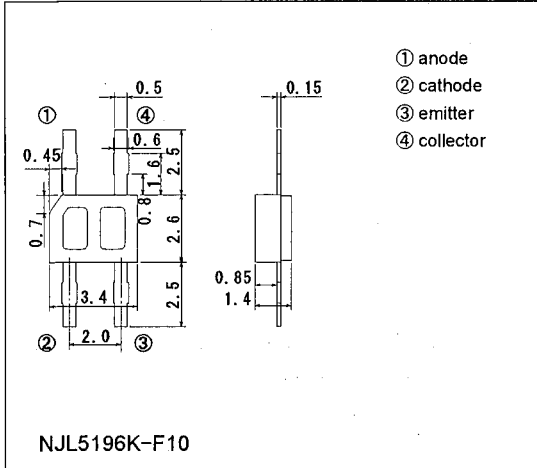

NJL5196K/97K

MEASURING SPECIFICATION FOR OUTPUT CURRENT

The output current can be measured when reflected at the aluminum

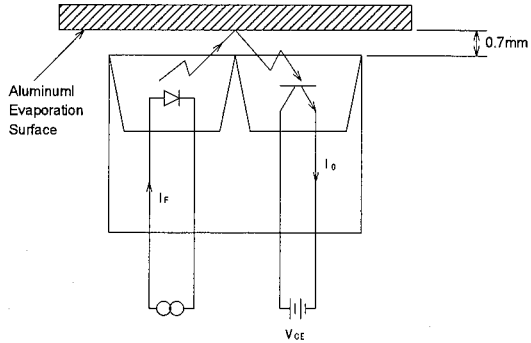

MEASURING CIRCUIT FOR OPERATING DARK CURRENT

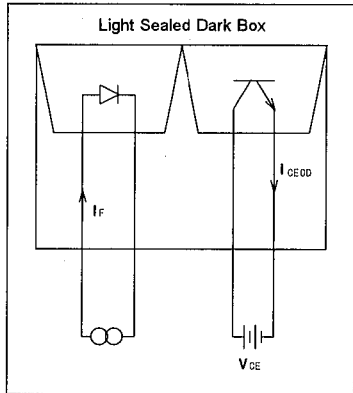

MEASURING SPECIFICATION FOR EDGE RESPONSE

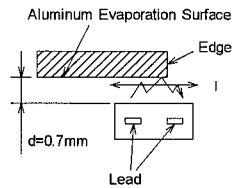

MEASURING CIRCUIT FOR RESPONSE TIME

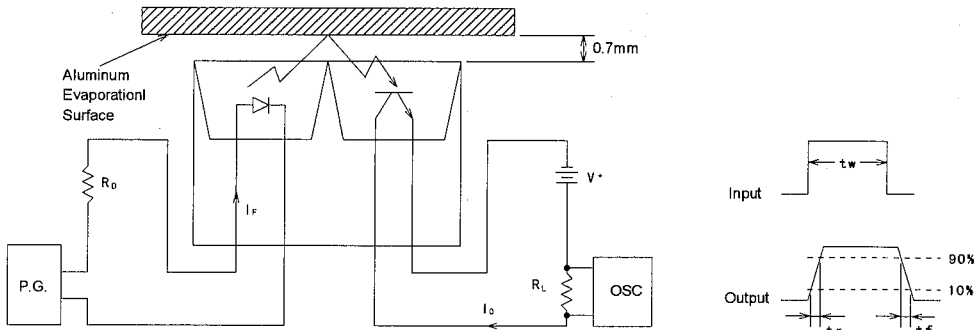

MAXIMUM RATING CURVES

Power Dissipation vs. Temperature

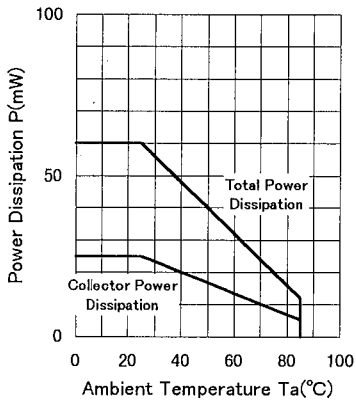

Forward Current vs. Temperature

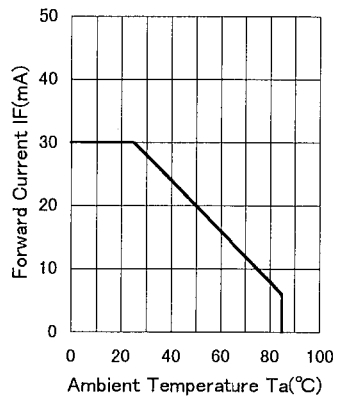

■ TYPICAL CHARACTERISTICS

Forward Current vs. Forward Voltage

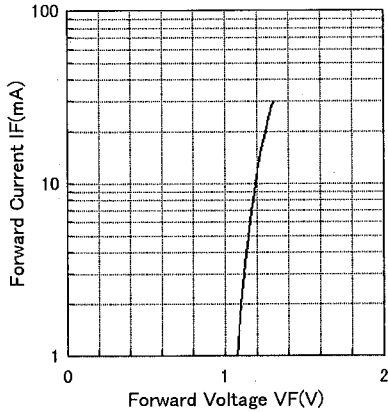

Forward Voltage vs. Temperature

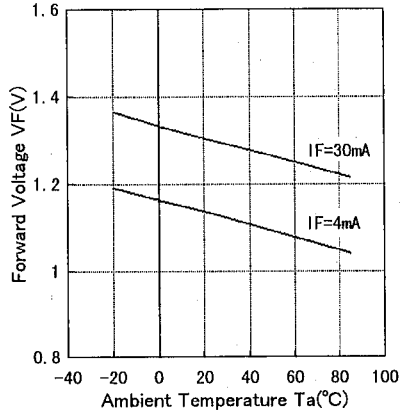

Dark Current vs. Temperature

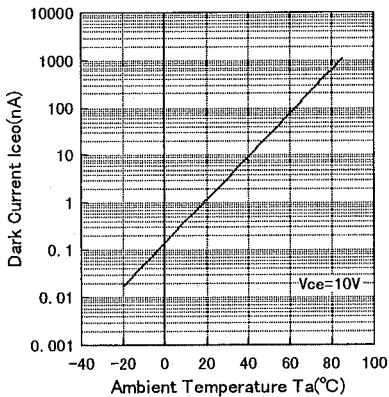

Operating Dark Current vs. Temperature

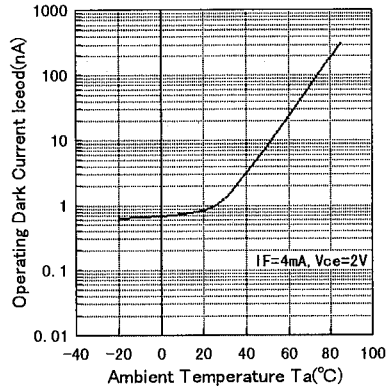

Output Current vs. Forward Current (Ta=25 °C)

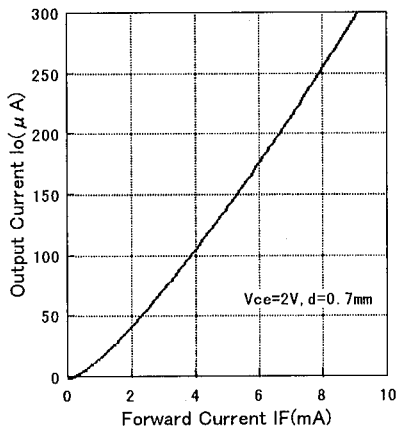

Output Current vs. Temperature

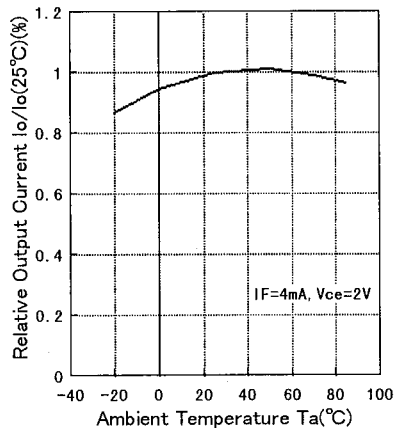

NJL5196K/97K

2

Output Characteristics (Ta=25 °C)

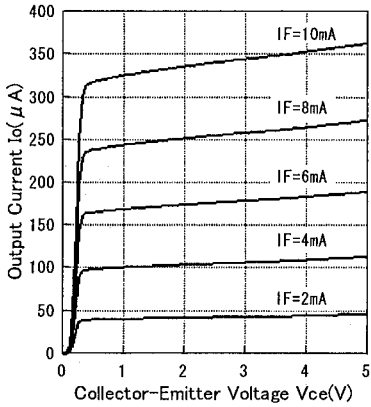

Vce Saturation (Ta=25 °C)

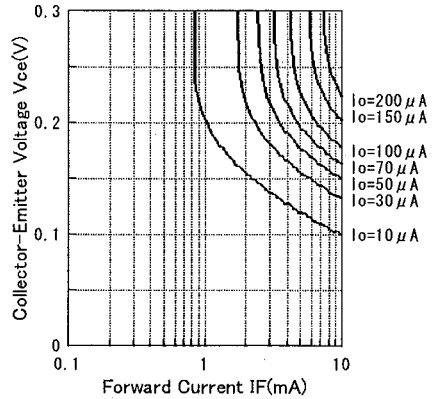

Output Current vs. Distance (Ta=25 °C)

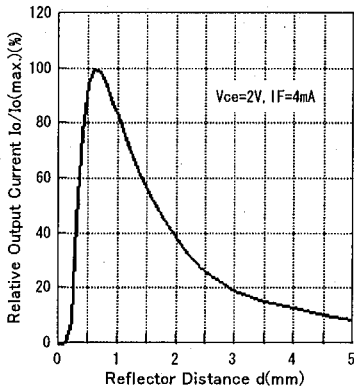

Output Current vs. Edge Distance (Ta=25 °C)

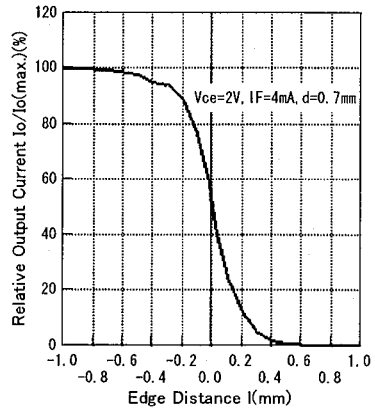

Spectral Response (Ta=25 °C)

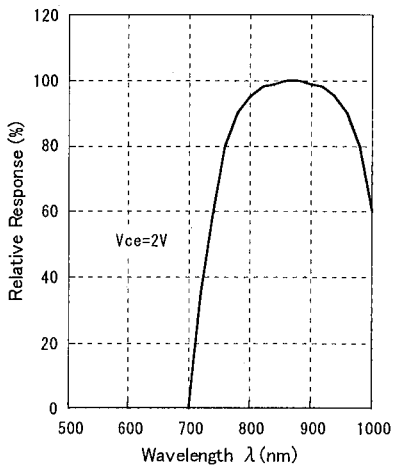

Switching Time vs. Load Resistance (Ta=25 °C)

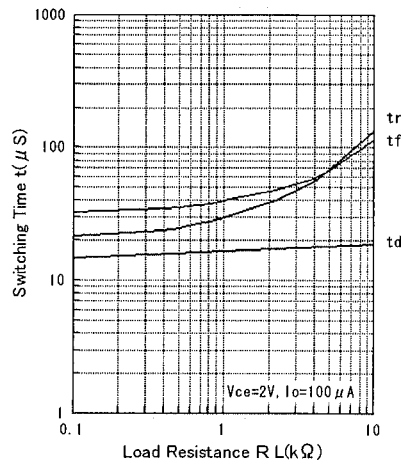

PRECAUTION FOR HANDLING

1. Soldering to actual circuit board

Soldering condition

- Lead's of soldering temperature and heating time.
260 °C maximum, less than 10 seconds, at least 1.5mm from body.
- Heated condition of plastic package.
Lower than 240 °C of maximum surface temperature, less than 30 seconds of time kept higher than 200 °C.

Soldering Method

1) Reflow Method

Recommended temperature profile of its method.

- ① Preparatory heating condition : 120 ~ 150 °C about 60 sec.
- ② Recommended soldering temperature : 230 ~ 240 °C about 3 ~ 5 sec.
- ③ Slowly cool down right after soldering.
- ④ Soldering to be done within twice under this condition.

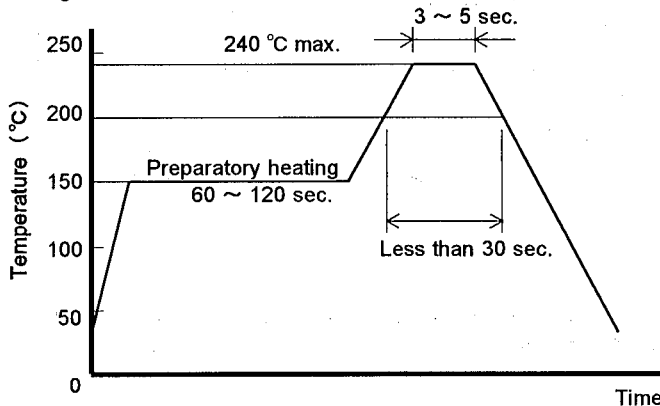

2) Reflow Method (In case of infrared heating)

- Temperature profile : Same to the above
- Avoid direct irradiation to the plastic package because it is black colored, absorbs the Infrared Radiation and its surface temperature will be higher than lead itself.

3) The other method

Avoid rapid heating up like dipping the devices directly into the melting solder or vapor phase method.

(VPS)

If the device is heated to high temperature and kept in its condition for longer time, it would affect to its reliability. It is necessary to solder in short time as soon as possible.

2. Cleaning

Avoid washing of the device after soldering by reflow method.

3. Attention in handling

- 1) Treat not to touch the lens surface.
- 2) Avoid dust and any other foreign materials (paint, bonding material, etc.) on the lens surface.
- 3) Never to apply reverse voltage (V_{EC}) of more than 6V on the photo transistor when measuring the characteristics or adjusting the system. If applied, it causes to lower the sensitivity.
- 4) When mounting, special care has to be taken on the mounting position and tilting of the device because it is very important to place the device to the optimum position to the object.

4. Storage

In order to prevent from degradation of this device in moisturing at reflow method, so that this device is contained in dampproof packaging. And the leads are silver plated and they are discolored if the device is left open to the air for long after taken out of the envelope. It causes deterioration of soldering characteristics. So that mount the device as short as possible after opening the envelope.

1. Taping Size

- 1) Carrier tape is used with Styrene type Carbonated Plastic.
- 2) Cover tape is used with electro statistically prevention treated Polyester type tape.
- 3) Product taping direction is to place the index mark against the pull out direction of the tape as in the drawing.

Pull out direction of tape →

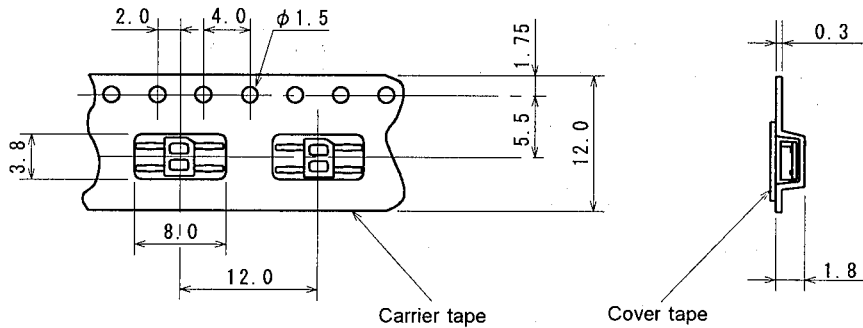

2. Taping Strength

Pullup the cover tape from the carrier tape, and when the opening angle comes around 10 ~ 15°, and the peeling-off strength is to be within the power of 20 ~ 70g.

3. Packaging

- 1) The taped products are to be rolled up on the taping reel as on the drawing.
- 2) Rolling up specification
 - ① Start Rolling : Carrier tape open space more than 20 Pieces.
 - ② End of Rolling : Carrier tape open space more than 20 Pieces, and 2 round of reel space at the cover tape only.
- 3) Taping quantity : 3,000 Pieces
- 4) Seal off after putting each reels in a vinyl bag with silica gel (3 bags).

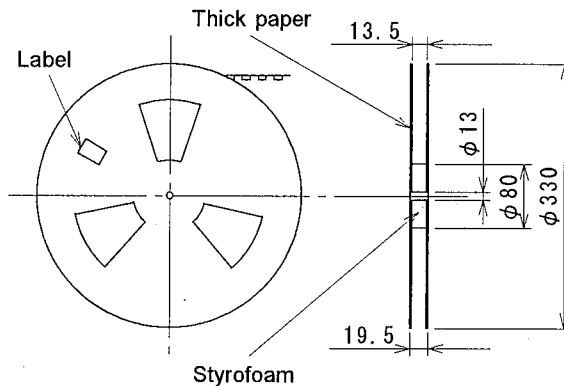

NJL5196K-F20/NJL5197K-F20 Taping Specification

(TE1)

1. Taping Size

- 1) Carrier tape is used with Styrene type Carbonated Plastic.
- 2) Cover tape is used with electro statistically prevention treated Polyester type tape.
- 3) Product taping direction is to place the index mark against the pull out direction of the tape as in the drawing.

Pull out direction of tape →

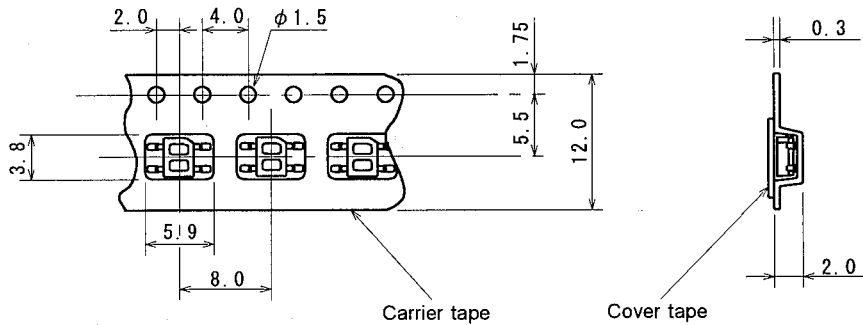

2

2. Taping Strength

Pullup the cover tape from the carrier tape, and when the opening angle comes around 10 ~ 15°, and the peeling-off strength is to be within the power of 20 ~ 70g.

3. Packaging

- 1) The taped products are to be rolled up on the taping reel as on the drawing.
- 2) Rolling up specification
 - ① Start Rolling : Carrier tape open space more than 20 Pieces.
 - ② End of Rolling : Carrier tape open space more than 20 Pieces, and 2 round of reel space at the cover tape only.
- 3) Taping quantity : 4,000 Pieces
- 4) Seal off after putting each reels in a vinyl bag with silica gel (3 bags).

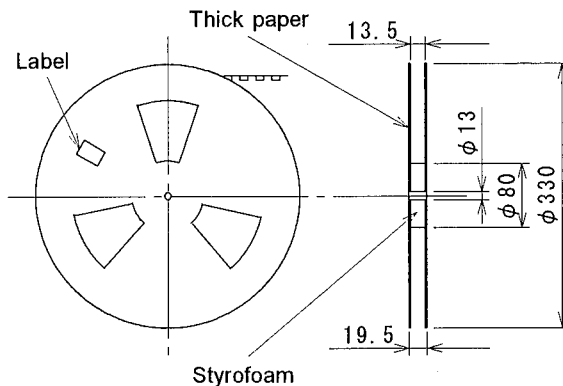

1. Taping Size

- 1) Carrier tape is used with Styrene type Carbonated Plastic.
- 2) Cover tape is used with electro statistically prevention treated Polyester type tape.
- 3) Product taping direction is to place the index mark against the pull out direction of the tape as in the drawing.

Pull out direction of tape →

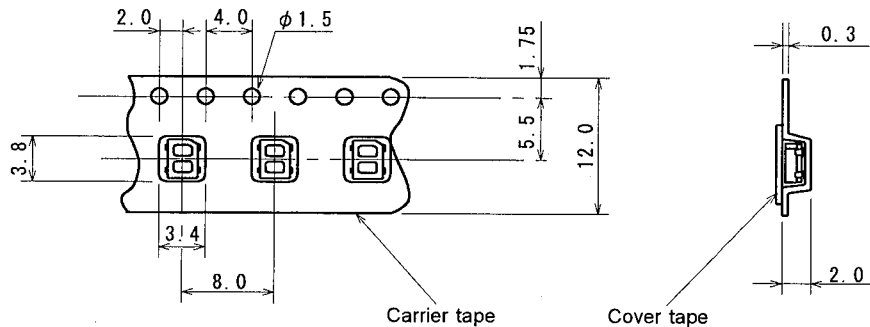

2. Taping Strength

Pullup the cover tape from the carrier tape, and when the opening angle comes around 10 ~ 15°, and the peeling-off strength is to be within the power of 20 ~ 70g.

3. Packaging

- 1) The taped products are to be rolled up on the taping reel as on the drawing.
- 2) Rolling up specification
 - ① Start Rolling : Carrier tape open space more than 20 Pieces.
 - ② End of Rolling : Carrier tape open space more than 20 Pieces, and 2 round of reel space at the cover tape only.
- 3) Taping quantity : 4,000 Pieces
- 4) Seal off after putting each reels in a vinyl bag with silica gel (3 bags).

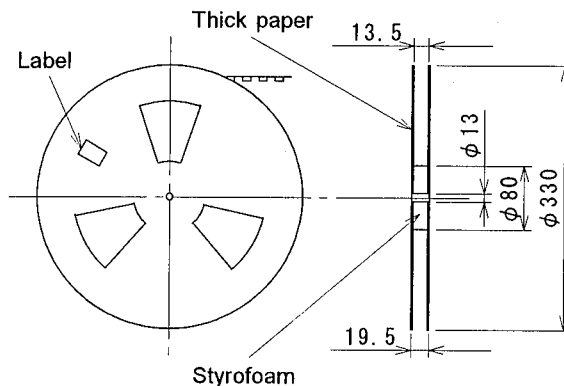

NJ5196K/97K

MEMO

[CAUTION]

The specifications on this databook are only given for information, without any guarantee as regards either mistakes or omissions. The application circuits in this databook are described only to show representative usages of the product and not intended for the guarantee or permission of any right including the industrial rights.