

## MONORAL MIC AMP. for VIDEO CAMERA

### ■ GENERAL DESCRIPTION

NJM2110 is a monaural microphone amplifier for video camera. It can operate from 2.7V.

The performance is low Operating current and small package, therefore it is easy to design the downsizing and low consumption.

### ■ FEATURES

- Operating Voltage 2.7V~5.3V
- Low Operating Current ( $V^*=5V:3.5mA$  Typ.)  
( $V^*=3.3V:1.1mA$  Typ.)
- Short Circuit Protection for External MIC.
- Package Outline DMP8, SSOP8
- Bipolar Technology

### ■ APPLICATION

- Video Camera

### ■ PIN CONFIGURATION

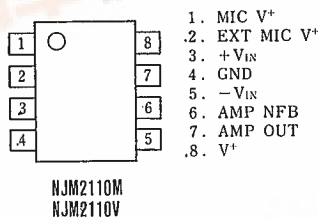

### ■ PACKAGE OUTLINE



NJM2110M



NJM2110V

### ■ BLOCK DIAGRAM

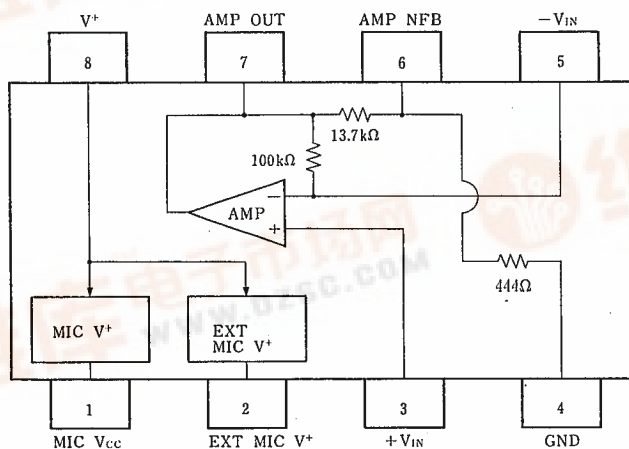

# NJM2110

## ■ ABSOLUTE MAXIMUM RATINGS

PARAMETER	SYMBOL	RATINGS	UNIT
Supply Voltage	V <sup>+</sup>	7.0	V
Power Dissipation	P <sub>D</sub>	(SSOP8) 250 (DMP8) 300	mW
Operating Temperature Range	T <sub>opr</sub>	-20~+75	°C
Storage Temperature Range	T <sub>stg</sub>	-40~+125	°C

## ■ ELECTRICAL CHARACTERISTICS

(V<sup>+</sup>=5V, T<sub>a</sub>=25°C)

PARAMETER	SYMBOL	TEST CONDITION	MIN.	TYP.	MAX.	UNIT
Operating Current 1	I <sub>cc 1</sub>		—	3.5	4.5	mA
Operating Current 2	I <sub>cc 2</sub>	V <sup>+</sup> =3.3V	—	1.1	2.0	mA
Transfer Gain	G <sub>v</sub>	f=1kHz	27	28	29	dB
Total Harmonic Distortion	THD	f=1kHz, V <sub>o</sub> =300mV <sub>rms</sub> , R <sub>L</sub> =10kΩ	—	0.05	0.2	%
Maximum Output Voltage	V <sub>om</sub>	f=1kHz, V <sup>+</sup> =2.7V, THD=1%, R <sub>L</sub> =10kΩ	2.0	2.5	—	V <sub>p-p</sub>
Output Noise Voltage	V <sub>no</sub>	R <sub>g</sub> =1kΩ, C=0.1μF, A-Weight	—	30	42	μV <sub>rms</sub>
Input Resistance Gain	Z <sub>in</sub>	f=1kHz	—	110	—	kΩ
Output Resistance	Z <sub>o</sub>	f=1kHz	—	10	—	Ω
MIC Output Supply Voltage 1	MIC <sub>O 1</sub>		2.0	2.35	2.7	V
MIC Output Supply Voltage 2	MIC <sub>O 2</sub>	V <sup>+</sup> =2.7V	2.0	2.25	2.5	V
External Output Supply Voltage	EXT <sub>out</sub>	I <sub>o</sub> =25mA	4.0	—	—	V
Output Short Circuit Current	I <sub>os</sub>	EXT <sub>O</sub> =0V	—	—	30	mA

5

## ■ TEST CIRCUIT

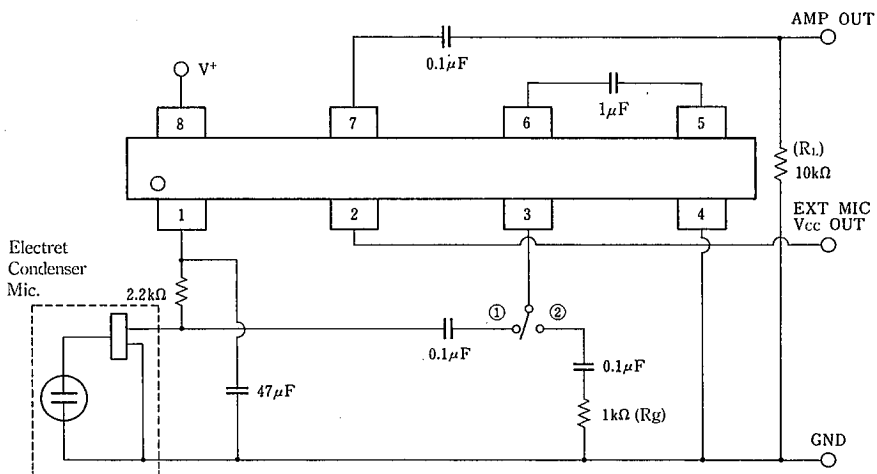

※SW②:Output Noise Voltage TEST

# NJM2110

---

## MEMO

**[CAUTION]**

The specifications on this databook are only given for information, without any guarantee as regards either mistakes or omissions. The application circuits in this databook are described only to show representative usages of the product and not intended for the guarantee or permission of any right including the industrial rights.