

## C-MOS QUAD SPST ANALOG SWITCH

### GENERAL DESCRIPTION

The NJU211 is a quad break-before-make SPST analog switch protected up to 40V operating voltage.

Each switch is controlled by TTL or C-MOS compatible input, and the input threshold level can be adjusted by external voltage supply control.

The NJU211 is functionally and pin-to-pin compatible with SILICONIX DG211A.

### PACKAGE OUTLINE

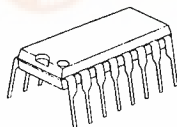

NJU211D

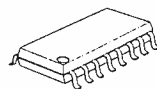

NJU211M

### FEATURES

- High Break Down Voltage -- 40V
- Input Threshold Voltage Adjustable
- Package Outline -- DIP/DMP 16
- C-MOS Technology

### PIN CONFIGURATION

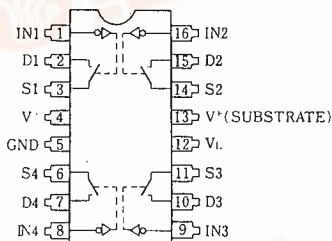

### TRUTH TABLE

Logic (In)	Switch
0	ON
1	OFF

### EQUIVALENT CIRCUIT

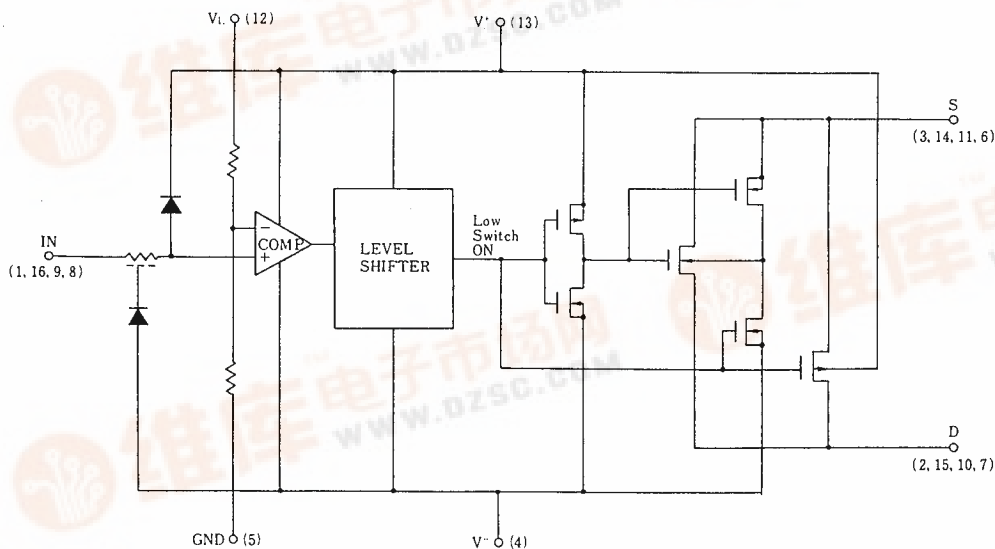

\* Logic input threshold voltage  $V_{TH}$  is about  $V_L \times 0.384(V)$ .  
When the designing, enough margin is required.

## ■ TERMINAL DESCRIPTION

No.	SYMBOL	FUNCTION	No.	SYMBOL	FUNCTION
1	IN1	Control Signal Input	9	IN3	Control Signal Input
2	D1	Input/Output 1	10	D3	Input/Output 3
3	S1		11	S3	
4	V <sup>-</sup>	Negative (V <sup>-</sup> ) Power Supply	12	V <sub>L</sub>	Threshold Level Control Voltage Supply
5	GND	Ground	13	V <sup>+</sup>	Positive (V <sup>+</sup> ) Power Supply
6	S4	Input/Output 4	14	S2	Input/Output 2
7	D4		15	D2	
8	IN4	Control Signal Input	16	IN2	Control Signal Input

## ■ ABSOLUTE MAXIMUM RATINGS

( Ta=25°C )

PARAMETER	SYMBOL	RATINGS	UNIT
Supply Voltage	V <sup>+</sup> - V <sup>-</sup>	40	V
	V <sup>+</sup> - GND	19	
	GND - V <sup>-</sup>	25	
Threshold Control Voltage	V <sub>L</sub> - GND	-0.5 ~ V <sup>+</sup> +0.5 *	
Input Voltage	V <sub>I</sub> , V <sub>S</sub> , V <sub>D</sub>	V <sup>-</sup> -0.5 ~ V <sup>+</sup> +0.5 *	V
Input Current	I <sub>I</sub>	30	mA
	I <sub>S</sub> , I <sub>D</sub> Continuous	20	
	Peak Value (PW=1ms, Duty0.1)	70	
Power Dissipation	P <sub>D</sub>	500 (DIP) 200 (DMP)	mW
Operating Temperature Range	T <sub>opr</sub>	0 ~ + 70	°C
Storage Temperature Range	T <sub>stg</sub>	- 65 ~ + 125	°C

 \* V<sup>+</sup>+0.5V must be 40V or less.

**ELECTRICAL CHARACTERISTICS (DC CHARACTERISTICS)**

 (  $V^+=15V$  ,  $V^-=-15V$  ,  $GND=0V$  ,  $V_L=5V$  )

PARAMETER	SYMBOL	CONDITIONS	TYP	MAX		UNIT		
			25°C	0°C	25°C		70°C	
Analog Signal Range	$V_{ANALOG}$		$\pm 15$		$\pm 15$	$\pm 15$	V	
On-state Resistance	$R_{ON}$	$V_{IN}=0.8V$	$V_D=10V$	105		175		$\Omega$
		$I_S=-1mA$	$V_D=-10V$	115		175		
Source-off Leakage Current	$I_S(off)$	$V_I=2.4V$	$V_S=14V, V_D=-14V$	0.01		5		nA
			$V_S=-14V, V_D=14V$	-0.02		- 5		
Drain-off Leakage Current	$I_D(off)$	$V_I=2.4V$	$V_D=14V, V_S=-14V$	0.01		5		nA
			$V_D=-14V, V_S=14V$	-0.02		- 5		
Drain-on Leakage Current	$I_D(on)$	$V_I=0.8V$	$V_D=V_S=14V$	0.1		5		nA
			$V_D=V_S=-14V$	-0.15		- 5		
Input Current	$I_{IH}$	$V_I=2.4V$		-0.0004		- 1		$\mu A$
		$V_I=15V$		0.003		1		
	$I_{IL}$	$V_I=0V$		-0.0004		- 1		
Quiescent Current	$I^+$	$V_I=0$ or $2.4V$		0.35		0.68		mA
	$I^-$			0.30		0.68		
	$I_L$			0.5		1.2		

6

**SWITCHING CHARACTERISTICS**

 (  $V^+=15V$  ,  $V^-=-15V$  ,  $GND=0V$  ,  $V_L=5V$  )

PARAMETER	SYMBOL	CONDITIONS	TYP	MAX		UNIT		
			25°C	0°C	25°C		70°C	
Turn-on Time	$t_{on}$	$R_L=1k\Omega$ , $C_L=35pF$	460		1000		ns	
Turn-off Time	$t_{off}$		360		500			
Charge Injection	Q	$C_L=1000pF$ , $V_{GEN}=0V$ , $R_{GEN}=0\Omega$	20				pC	
Source-Off Capacit.	$C_S(off)$	$f=100kHz$	$V_S=0V$ , $V_I=5V$	5			pF	
Drain-Off Capacit.	$C_D(off)$		$V_D=0V$ , $V_I=5V$	5				
Channel-On Capacitance	$C_D(on)$ + $C_S(on)$		$V_D=V_S=0V$ , $V_I=0V$	16				
Off Isolation	OIRR		$V_S=2V_{P-P}$ , $R_L=75\Omega$	70				
Channel-to-channel Crosstalk	CCRR		90					

# NJU211

---

## MEMO

[CAUTION]  
The specifications on this databook are only given for information, without any guarantee as regards either mistakes or omissions. The application circuits in this databook are described only to show representative usages of the product and not intended for the guarantee or permission of any right including the industrial rights.