



PRELIMINARY

NJW1156



2-CHANNEL ELECTRONIC VOLUME WITH INPUT SELECTOR

GENERAL DESCRIPTION

NJW1156 is a two channel electronic volume with 5 input selector. It's suitable for Input signal trimmer of audio equipments such as DVD / HDD recorder and VCR. These functions are controlled by I²C Bus.

PACKAGE OUTLINE



NJW1156V

NJW1156M

FEATURES

- Operating Voltage 8 to 13V
- I²C Bus control
- 5 Input Selector
- Volume 0 to -39.5dB/0.5dBstep, MUTE
- Bi-CMOS Technology
- Package Outline SSOP20, DMP20

BLOCK DIAGRAM

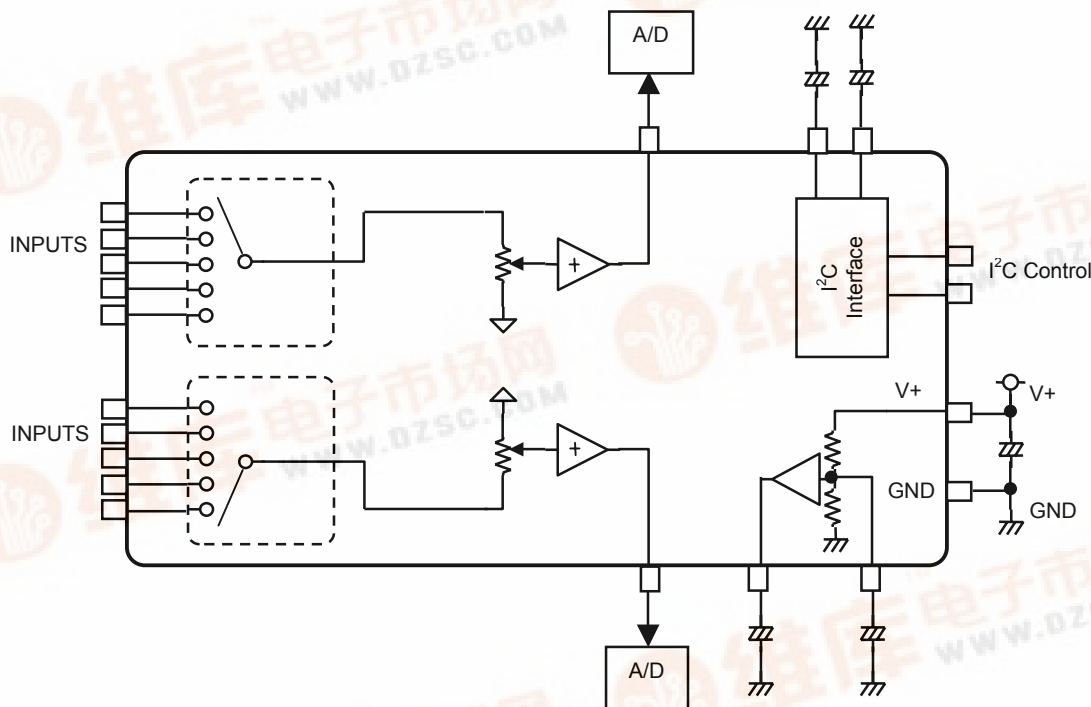

■ PIN FUNCTION

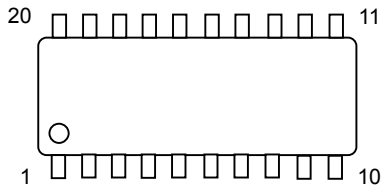

No.	SYMBOL	FUNCTION
1	GND	Ground
2	R1IN	R channel Input 1
3	R2 IN	R channel Input 2
4	R3IN	R channel Input 3
5	R4IN	R channel Input 4
6	R5IN	R channel Input 5
7	ROUT	R channel Output
8	VSSOUT	Internal VSS Noise Rejection Capacitor Terminal
9	SCL	I ² C Clock Input
10	SDA	I ² C Data Input
11	VDDOUT	Internal VDD Noise Rejection Capacitor Terminal
12	VREFOUT	Reference Voltage Output
13	V+	Power Supply
14	VREFIN	Reference Voltage Noise Rejection Capacitor Terminal
15	LOUT	L channel Output
16	L5IN	L channel Input 5
17	L4IN	L channel Input 4
18	L3IN	L channel Input 3
19	L2IN	L channel Input 2
20	L1IN	L channel Input 1

■ ABSOLUTE MAXIMUM RATING (Ta=25°C)

PARAMETER	SYMBOL	RATING	UNIT
Power Supply Voltage	V+	15	V
Power Dissipation	P _D	375	mW
Operating Temperature Range	Topr	-20 to +75	°C
Storage Temperature Range	Tstg	-40 to +125	°C

■ ELECTRICAL CHARACTERISTICS (Ta=25°C, V⁺=+12V)

PARAMETER	SYMBOL	TEST CONDITION	MIN.	TYP.	MAX.	UNIT
◆ Power Supply						
Operating Voltage	V+	-	8	12	13	V
Reference Voltage	V _{ref}	-	5.5	6	6.5	V
Supply Current	I _{CC}	No signal	-	4.5	6.8	mA
◆ Input/Output Characteristics						
Maximum Output Voltage	V _{OM}	f=1kHz, THD=1% Volume=0dB	3.0	4.0	-	Vrms
Voltage Gain 1	G _{V1}	V _{IN} =1Vrms, f=1kHz Volume=0dB	-0.5	0	0.5	dB
Voltage Gain 2	G _{V2}	V _{IN} =1Vrms, f=1kHz Volume=-20dB	-21	-20	-19	dB
Voltage Gain 3	G _{V3}	V _{IN} =1Vrms, f=1kHz Volume=-39.5dB	-42.0	-39.5	-37.0	dB
Voltage Gain Error	ΔG _V	V _{IN} =1Vrms, f=1kHz Volume=-20dB, Ach - Bch	-0.5	0	0.5	dB
Mute Level	Mute	f=1kHz, V _{IN} =1Vrms Volume=Mute, A-weight	-	-100	-	dB
Output Noise	V _{NO}	Volume=0dB, Rg=0, A-weight	-	-110 (3.2μ)	-100 (10μ)	dBV (Vrms)
Total Harmonic Distortion	THD	f=1kHz, Vo=1Vrms, Volume=0dB BW : 400Hz - 30kHz	-	0.0015	0.05	%
Channel Separation	CS	f=1kHz, Vo=1Vrms, Volume=0dB Rg=0Ω, A-weight	-	-100	-90	dB

■ I²C BUS BLOCK CHARACTERISTICS (SDA,SCL)

PARAMETER	SYMBOL	MIN.	TYP.	MAX.	UNIT
High Level Input Voltage	V_{IH}	2.5	-	5.0	V
Low Level Input Voltage	V_{IL}	0	-	1.5	V
High Level Input Current	I_{IH}	-	-	10	μA
Low Level Input Current	I_{IL}	-	-	10	μA
Low Level Output Voltage (3mA at SDA pin)	V_{OL}	0	-	0.4	V
Maximum Output Current	I_{OL}	-3.0	-	-	mA
Maximum Clock Frequency	f_{SCL}	-	-	100	kHz
Data Change Minimum Waiting Time	t_{BUF}	4.7	-	-	μs
Data Transfer Start Minimum Waiting Time	$t_{HD:STA}$	4.0	-	-	μs
Low Level Clock Pulse Width	t_{LOW}	4.7	-	-	μs
High Level Clock Pulse Width	t_{HIGH}	4.0	-	-	μs
Minimum Start Preparation Waiting Time	$t_{SU:STA}$	4.7	-	-	μs
Minimum Data Hold Time	$t_{HD:DAT}$	5.0	-	-	μs
Minimum Data Preparation Time	$t_{SU:DAT}$	250	-	-	ns
Rise Time	t_R	-	-	1.0	μs
Fall Time	t_F	-	-	300	ns
Minimum Stop Preparation Waiting Time	$t_{SU:STO}$	4.0	-	-	μs

I²C BUS Load Condition: Pull up resistance 4k Ω (Connected to +5V)
 Load capacitance 200pF (Connected to GND)

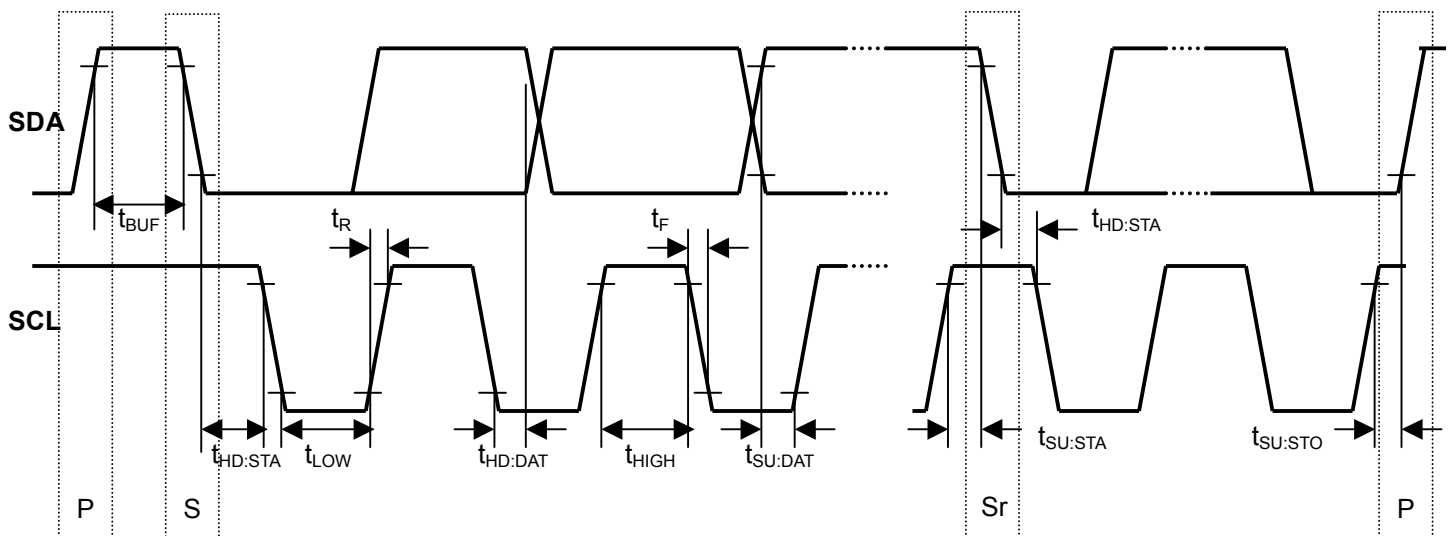

■ TERMINAL DESCRIPTION

PIN NO.	SYMBOL	FUNCTION	EQUIVALENT CIRCUIT	TERMINAL DC VOLTAGE
2 3 4 5 6 16 17 18 19 20	R1IN R2IN R3IN R4IN R5IN L5IN L4IN L3IN L2IN L1IN	R channel Input 1 R channel Input 2 R channel Input 3 R channel Input 4 R channel Input 5 L channel Input 5 L channel Input 4 L channel Input 3 L channel Input 2 L channel Input 1		$V^+/2$
7 15	ROUT LOUT	Rch Output Lch Output		$V^+/2$
8 11	VSS_OUT VDD_OUT	Internal VSS Noise Rejection Capacitor Terminal Internal VDD Noise Rejection Capacitor Terminal		$VSS_OUT = V_{ref} - 2.5V$ $VDD_OUT = V_{ref} + 2.5V$
9	SCL	I ² C Clock Input		-

■ TERMINAL DESCRIPTION

PIN NO.	SYMBOL	FUNCTION	EQUIVALENT CIRCUIT	TERMINAL DC VOLTAGE
10	SDA	I ² C Data Input		-
12	VREFOUT	Reference Voltage Output		V ⁺ /2
13	V+	Power Supply		V ⁺
14	VREFIN	Reference Voltage Noise Rejection Capacitor Terminal		V ⁺ /2

■ APPLICATION CIRCUIT

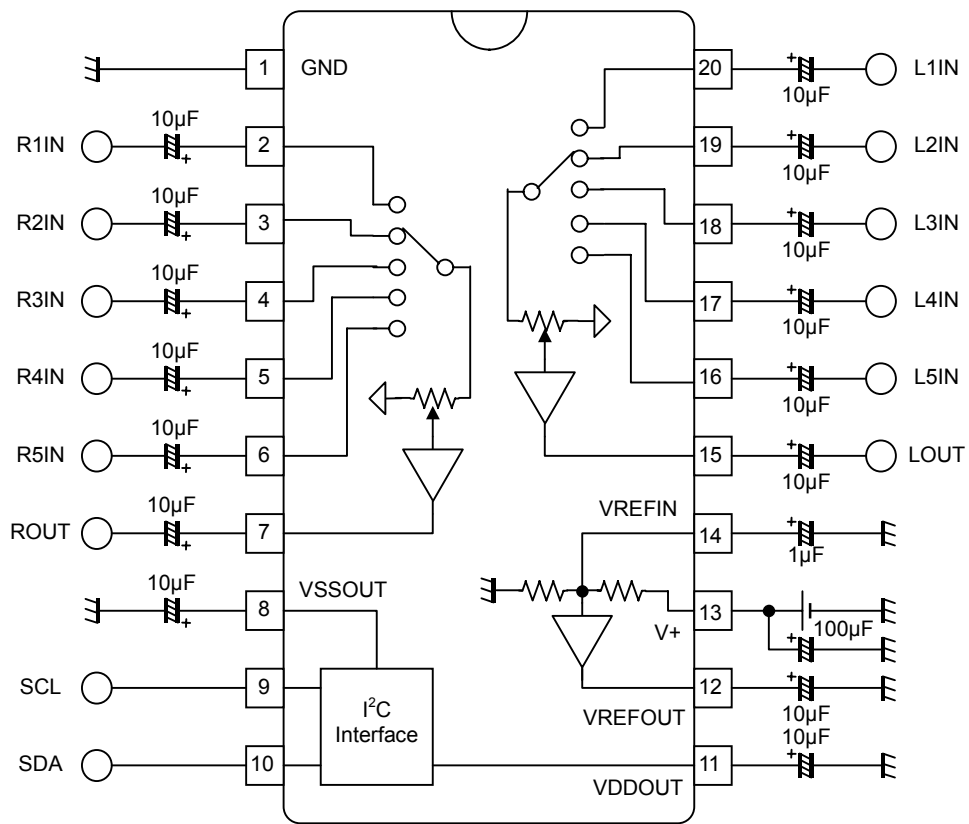

■ DEFINITION OF I²C REGISTER

◆ I²C BUS FORMAT

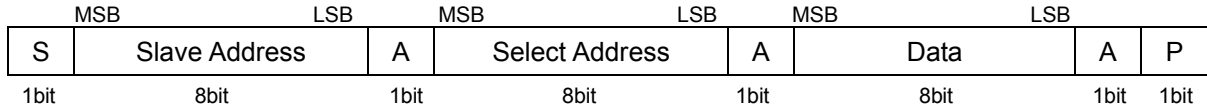

S: Starting Term
 A: Acknowledge Bit
 P: Ending Term

◆ SLAVE ADDRESS

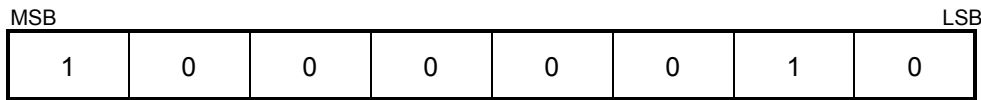

◆ CONTROL REGISTER TABLE

The select address sets each function (Volume, Selector).
 The auto increment function cycles the select address as follows.
 00H → 01H → 02H → 00H

Select Address	BIT							
	D7	D6	D5	D4	D3	D2	D1	D0
00H	Don't Care	VOLa						
01H	Don't Care	VOLb						
02H	Don't Care	TEST	OFF	Don't Care		Selector		

◆ CONTROL REGISTER DEFAULT VALUE

Control register default value is all "0".

Select Address	BIT							
	D7	D6	D5	D4	D3	D2	D1	D0
00H	0	0	0	0	0	0	0	0
01H	0	0	0	0	0	0	0	0
02H	0	0	0	0	0	0	0	0

■ CONTROL COMMAND TABLE

a) Master Volume

Select Address	BIT						
	D7	D6	D5	D4	D3	D2	D1
00H	Don't Care	VOLa					
01H	Don't Care	VOLb					

•VOLa / VOLb : Ach and Bch volume level setting from 0dB to -39.5dB with 0.5dB step.

Gain (dB)	VOLa / VOLb						
	D6	D5	D4	D3	D2	D1	D0
0	0	0	0	0	0	0	0
-0.5	0	0	0	0	0	0	1
-1	0	0	0	0	0	1	0
-1.5	0	0	0	0	0	1	1
-2	0	0	0	0	1	0	0
-2.5	0	0	0	0	1	0	1
-3	0	0	0	0	1	1	0
-3.5	0	0	0	0	1	1	1
-4	0	0	0	1	0	0	0
-4.5	0	0	0	1	0	0	1
-5	0	0	0	1	0	1	0
-5.5	0	0	0	1	0	1	1
-6	0	0	0	1	1	0	0
-6.5	0	0	0	1	1	0	1
-7	0	0	0	1	1	1	0
-7.5	0	0	0	1	1	1	1
-8	0	0	1	0	0	0	0
-8.5	0	0	1	0	0	0	1
-9	0	0	1	0	0	1	0
-9.5	0	0	1	0	0	1	1
-10	0	0	1	0	1	0	0
-10.5	0	0	1	0	1	0	1
-11	0	0	1	0	1	1	0
-11.5	0	0	1	0	1	1	1
-12	0	0	1	1	0	0	0
-12.5	0	0	1	1	0	0	1
-13	0	0	1	1	0	1	0
-13.5	0	0	1	1	0	1	1
-14	0	0	1	1	1	0	0
-14.5	0	0	1	1	1	0	1
-15	0	0	1	1	1	1	0
-15.5	0	0	1	1	1	1	1
-16	0	1	0	0	0	0	0
-16.5	0	1	0	0	0	0	1
-17	0	1	0	0	0	1	0
-17.5	0	1	0	0	0	1	1
-18	0	1	0	0	1	0	0
-18.5	0	1	0	0	1	0	1
-19	0	1	0	0	1	1	0
-19.5	0	1	0	0	1	1	1
-20	0	1	0	1	0	0	0
...
-39.5	1	0	0	1	1	1	1
Mute	1	1	1	1	1	1	1

b) Input Selector

Select Address	BIT							
	D7	D6	D5	D4	D3	D2	D1	D0
01H	Don't Care	TEST	OFF	Don't Care		Selector		

•Selector : Input signal selecting

Input	Selector		
	D2	D1	D0
L1IN / R1IN	0	0	0
L2IN / R2IN	0	0	1
L3IN / R3IN	0	1	0
L4IN / R4IN	0	1	1
L5IN / R5IN	1	0	0

■ TYPICAL CHARACTERISTICS

Operating Current vs. Supply Voltage
Ta=25°C

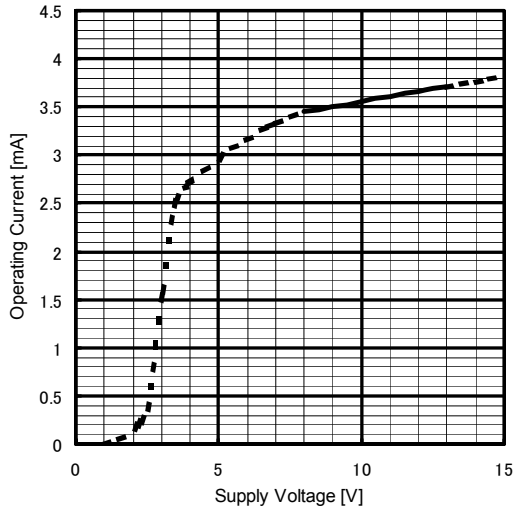

Voltage Gain vs. Attenuator Set Level
Ta=25°C

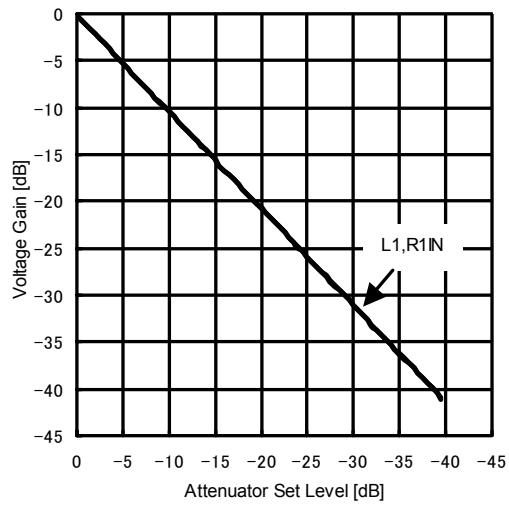

THD+N vs. Input Level
V*=12V, VOL=0dB, BW=10Hz-80kHz
INPUT:L1IN, OUTPUT:LOUT

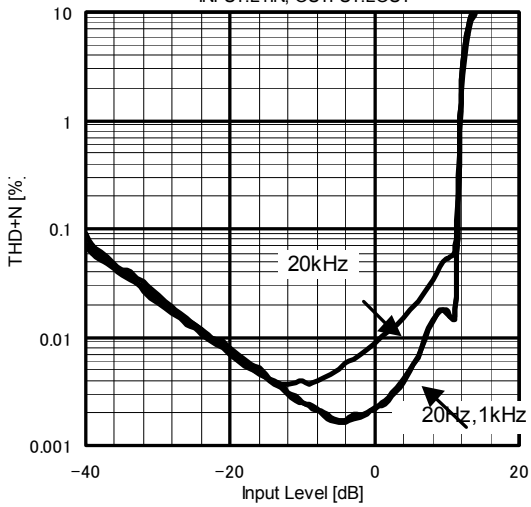

THD+N vs. Input Level
V*=12V, f=1kHz, BW=10Hz-80kHz
INPUT:L1IN, OUTPUT:LOUT

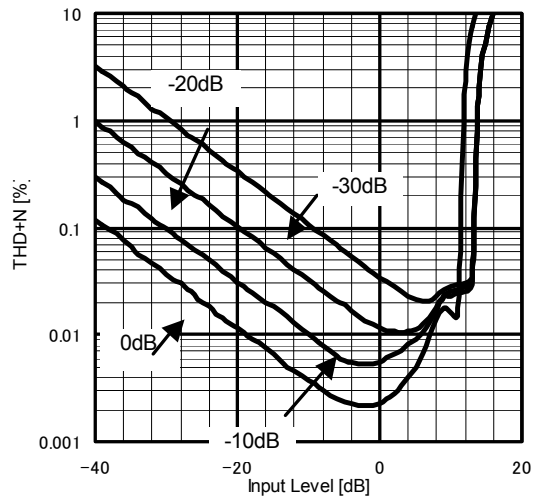

Operating Current vs. Supply Voltage

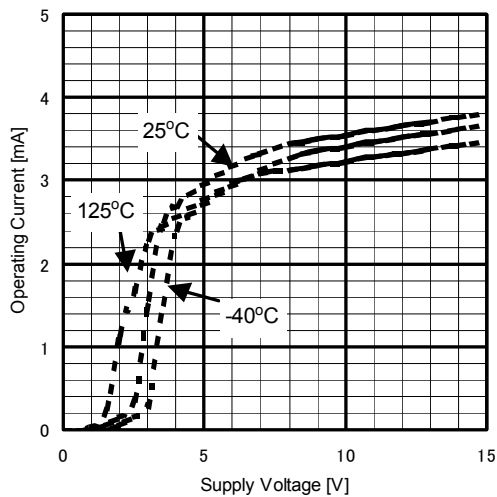

Operating Current vs. Ambient Temperature
V*=12V

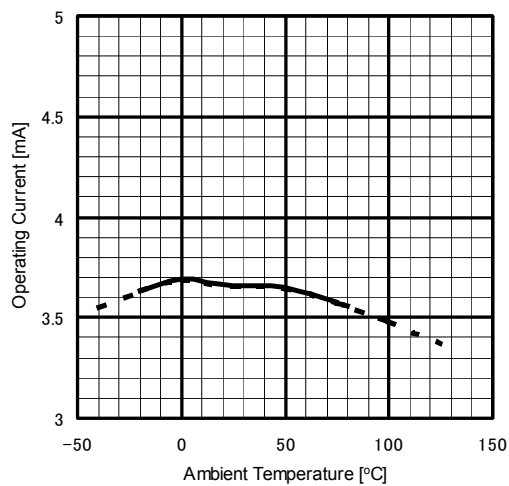

■ TYPICAL CHARACTERISTICS

Voltage Gain vs. Ambient Temperature
 $V^+=12V, V_{in}=1V, f=1kHz, Vol=0dB$

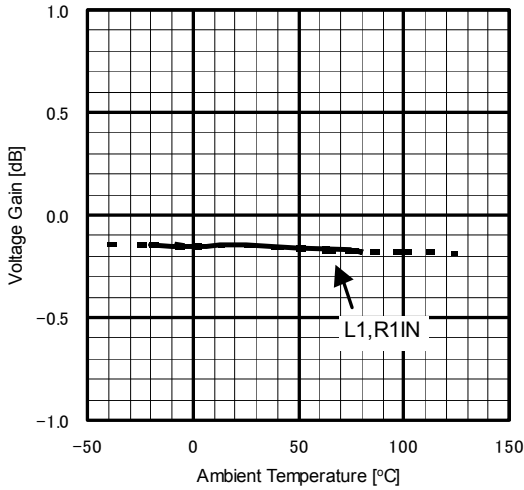

Attenuation Level vs. Ambient Temperature
 $V^+=12V, V_{in}=1V, f=1kHz, Vol=-20dB$

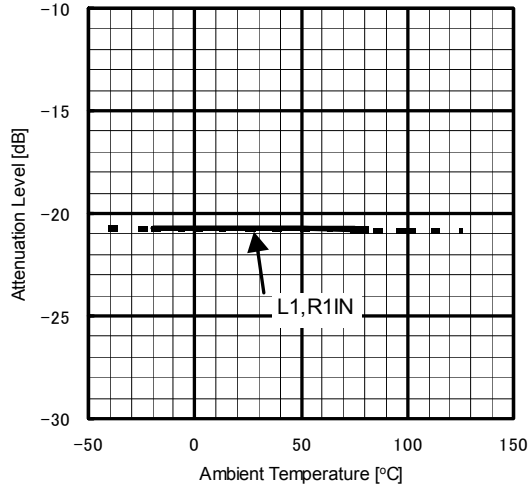

Attenuation Level vs. Ambient Temperature
 $V^+=12V, V_{in}=1V, f=1kHz, Vol=-39.5dB$

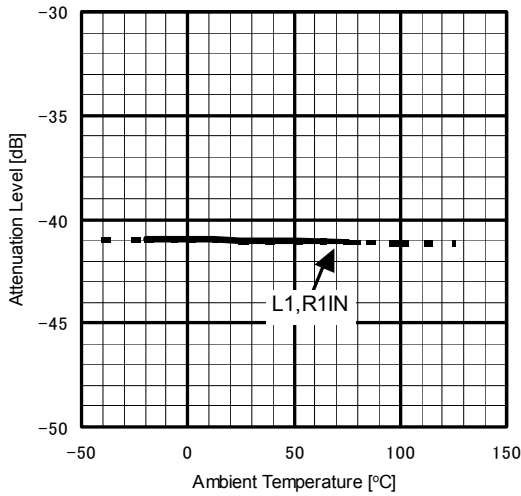

Attenuation Level vs. Ambient Temperature
 $V^+=12V, V_{in}=1V, f=1kHz, Vol=Mute$

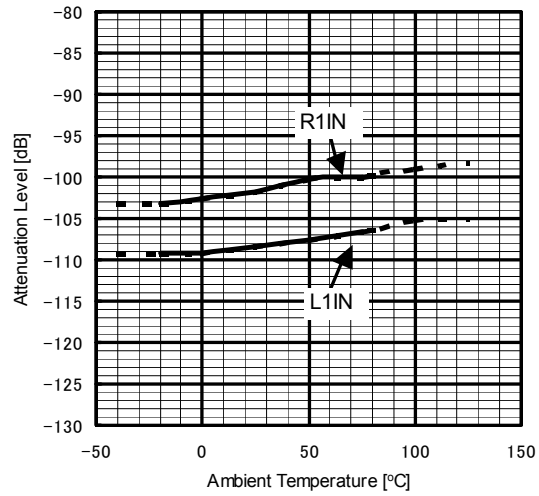

Maximum Output Voltage vs. Ambient Temperature
 $V^+=12V, f=1kHz, THD+N=1%, Vol=0dB$

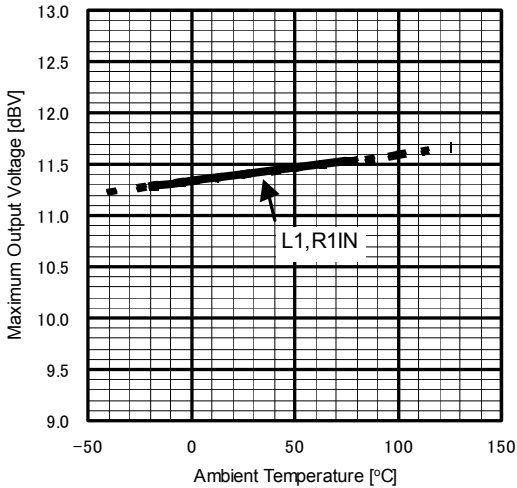

Output Noise Level vs. Ambient Temperature
 $V^+=12V, R_g=0\Omega, Vol=0dB, A-w eight$

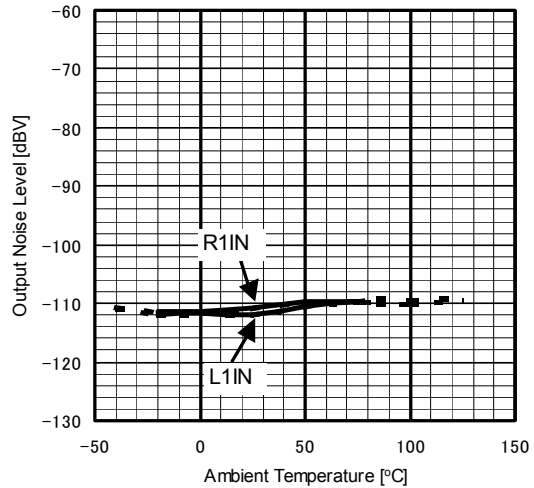

■ TYPICAL CHARACTERISTICS

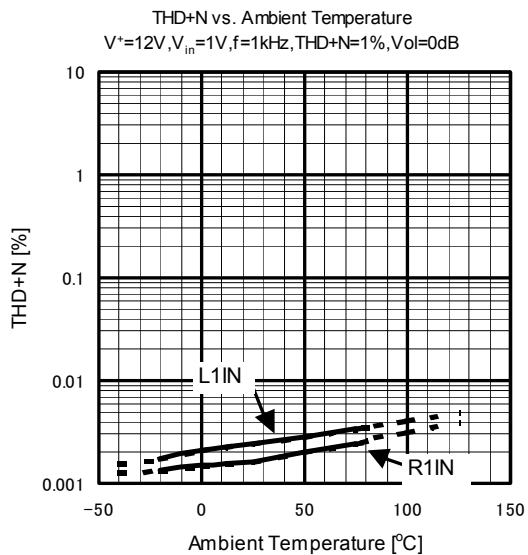

■NOTE

Purchase of I²C components of New Japan Radio Co., Ltd or one of its sublicensed Associated Companies conveys a license under the Philips I²C Patent Rights to use these components in an I²C system, provided that the system conforms to the I²C Standard Specification as defined by Philips.

[CAUTION]

The specifications on this databook are only given for information , without any guarantee as regards either mistakes or omissions. The application circuits in this databook are described only to show representative usages of the product and not intended for the guarantee or permission of any right including the industrial rights.