

FEATURES

- New Sub-Miniature SIP & DIP Styles
- 3kVDC Isolation
- Efficiency to 81%
- Wide Temperature performance at full 1 Watt load, -40°C to 85°C
- Increased Power Density to 1.95W/cm³
- UL 94V-0 Package Material
- Footprint 0.69cm²
- Single Isolated Output
- Industry Standard Pinout
- 3.3V, 5V & 12V Input
- 3.3V, 5V, 9V, 12V and 15V Output
- No Heatsink Required
- Internal SMD Construction
- Fully Encapsulated with Toroidal Magnetics
- No External Components Required
- MTF up to 2.4 Million hours
- Custom Solutions Available
- No Electrolytic or Tantalum Capacitors

DESCRIPTION

The NKE sub-miniature series of DC-DC Converters is particularly suited to isolating and/or converting DC power rails. A smaller package size, improved efficiency, lower output ripple and 3kVDC isolation capability through state of the art packaging and improved technology. The galvanic isolation allows the device to be configured to provide an isolated negative rail in systems where only positive rails exist. The wide temperature range guarantees startup from -40°C and full 1 watt output at 85°C.

SELECTION GUIDE

	Nominal Input Voltage	Output Voltage	Output Current	Input Current at Rated Load	Efficiency	Isolation Capacitance	MTTF ¹
OrderCode [†]	(V)	(V)	(mA)	(mA)	(%)	(pF)	kHrs
NKE0303S	3.3	3.3	303	400	75	30	1234
NKE0305S	3.3	5	200	400	76	35	632
NKE0503S	5	3.3	303	270	75	40	619
NKE0505SE	5	5	200	250	78	34	419
NKE0505S	5	5	200	289	69	28	2414
NKE0509S	5	9	111	266	75	29	1173
NKE0512S	5	12	83	260	77	30	633
NKE0515S	5	15	66	256	78	32	360
NKE1205S	12	5	200	117	71	35	620
NKE1209S	12	9	111	107	78	50	488
NKE1212S	12	12	83	105	79	57	360
NKE1215S	12	15	66	103	81	60	252

[†] For DIP package style replace suffix S with D, eg NKE0303D.
When operated with additional external load capacitance the rise time of the input voltage will determine the maximum external capacitance value for guaranteed start up. The slower the rise time of the input voltage the greater the maximum value of the additional external capacitance for reliable start up.

INPUT CHARACTERISTICS

Parameter	Conditions	MIN	TYP	MAX	Units
Voltage Range	Continuous operation, 3.3V input types	2.97	3.3	3.63	V
	Continuous operation, 5V input types	4.5	5.0	5.5	
	Continuous operation, 12V input types	10.8	12.0	13.2	
Reflected Ripple Current			40	60	mA p-p

OUTPUT CHARACTERISTICS

Parameter	Conditions	TYP	MAX	Units
Rated Power ²	T _A = -40°C to 85°C		1	W
Voltage Set Point Accuracy	See tolerance envelope			
Line regulation	High V _{IN} to low V _{IN}	1.0	1.2	%/%
Load Regulation ³	10% load to rated load, 3.3V output types	10	15	%
	10% load to rated load, 5V output types	12	15	
	10% load to rated load, 9V output types	7.5	10	
	10% load to rated load, 12V output types	6.5	9.5	
	10% load to rated load, 15V output types	6.0	8.5	
Ripple and Noise	BW=DC to 20MHz, 3.3V output types	40	80	mV p-p
	BW=DC to 20MHz, 5V output types	77	100	
	BW=DC to 20MHz, 9V output types	43	90	
	BW=DC to 20MHz, 12V output types	35	65	
	BW=DC to 20MHz, 15V output types	32	55	

ABSOLUTE MAXIMUM RATINGS

Short circuit duration ⁴	1 second
Internal power dissipation	530mW
Lead temperature 1.5mm from case for 10 seconds	300°C
Input voltage V _{in} NKE03 types	5.5V
Input voltage V _{in} NKE05 types	7V
Input voltage V _{in} NKE12 types	15V

1 Calculated using MIL-HDBK-217F with nominal input voltage at full load.
2 See derating curve.
3 12V input types have typically 3% less load regulation change.
4 Supply voltage must be discontinued at the end of the short circuit duration.
All specifications typical at T_A=25°C, nominal input voltage and rated output current unless otherwise specified.



NKE SERIES

Isolated Sub-Miniature 1W Single Output DC-DC Converters

ISOLATION CHARACTERISTICS

Parameter	Conditions	MIN	TYP	MAX	Units
Isolation Test Voltage	Flash tested for 1 second	3000			VDC
Resistance	Viso=500VDC		10		G

GENERAL CHARACTERISTICS

Parameter	Conditions	MIN	TYP	MAX	Units
Switching Frequency	All input types		115		kHz

TEMPERATURE CHARACTERISTICS

Parameter	Conditions	MIN	TYP	MAX	Units
Specification	All output types	-40		85	°C
Storage		-50		130	°C
Case Temperature above ambient	0505D/S, 1205D/S			41	°C
	All other output types			32	°C
Cooling	Free air convection				

PERFORMANCE CHARACTERISTICS

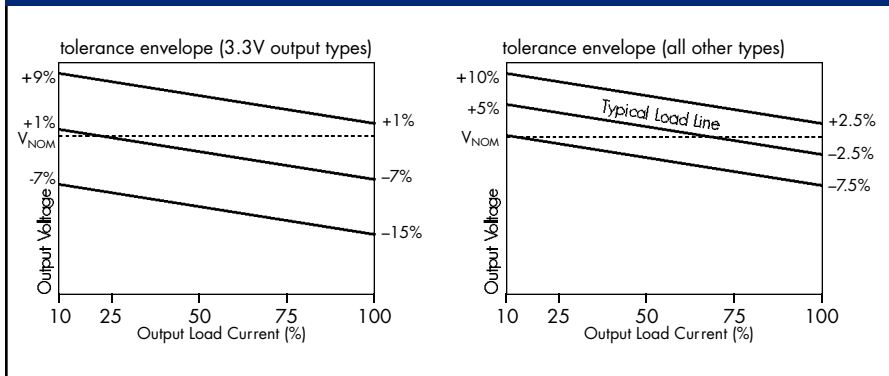

TEMPERATURE CHARACTERISTICS

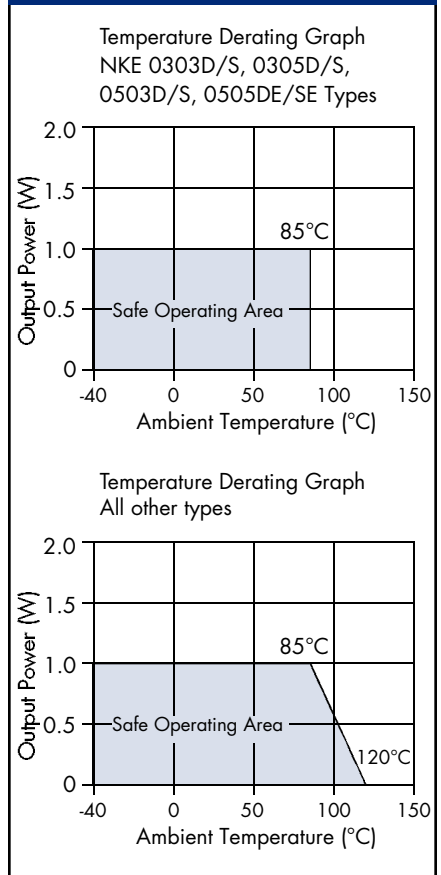

MECHANICAL DIMENSIONS

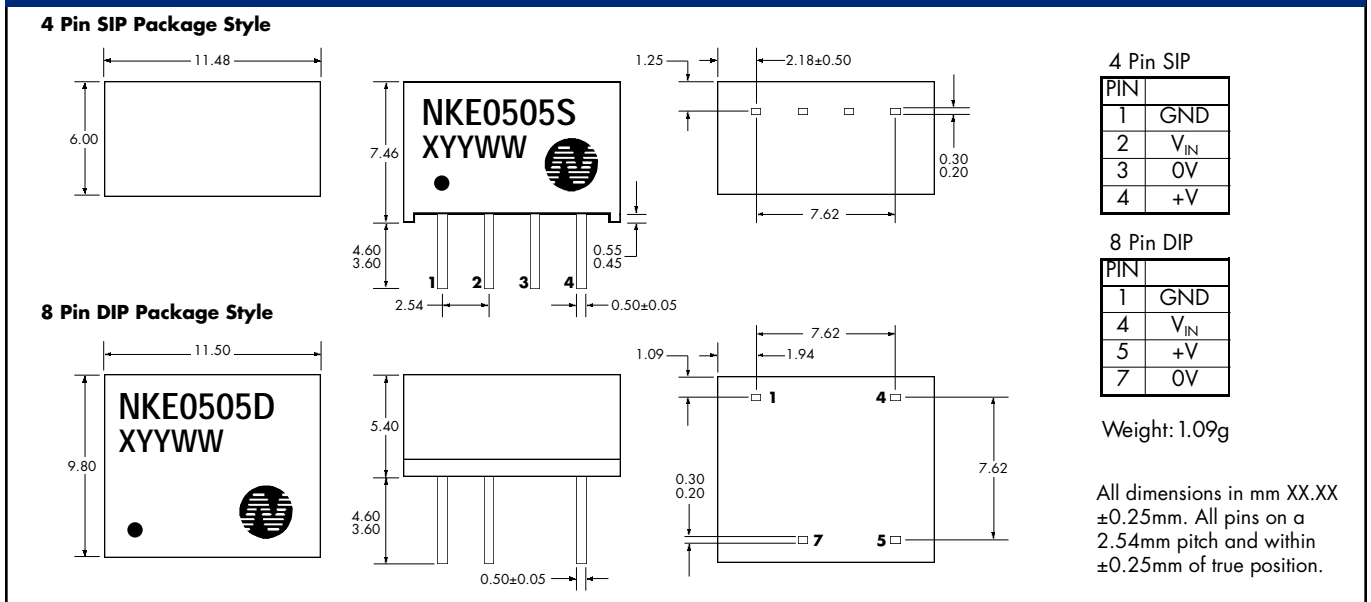

C&D Technologies (NCL) Limited reserve the right to alter or improve the specification, internal design or manufacturing process at any time, without notice. Please check with your supplier or visit our web site to ensure that you have the current and complete specification for your product before use.

© C&D Technologies (NCL) Limited 2001 NDC NKE.5

No part of this publication may be copied, transmitted or stored in a retrieval system or reproduced in any way including, but not limited to, photography, photocopy, magnetic or other recording means, without prior written permission from C&D Technologies (NCL) Limited.

Instructions for use are available from www.dc-dc.com

C&D Technologies (NCL) Ltd
 Tanners Drive, Blakelands North
 Milton Keynes MK14 5BU, England
 Tel: +44 (0)1908 615232
 Fax: +44 (0)1908 617545
 email: info@cdtechno-ncl.com

[www: http://www.dc-dc.com](http://www.dc-dc.com)

C&D Technologies (NCL), Inc.
 5816 Creedmoor Road, Raleigh
 NC 27612, USA
 Tel: +1 (919) 571-9405
 Fax: +1 (919) 571-9262
 email: info@us.cdtechno-ncl.com