

NTQD6866R2

Power MOSFET 6.9 Amps, 20 Volts N-Channel TSSOP-8

Features

- New Low Profile TSSOP-8 Package
- Ultra Low R_{DS(on)}
- Higher Efficiency Extending Battery Life
- Logic Level Gate Drive
- Diode Exhibits High Speed, Soft Recovery
- Avalanche Energy Specified
- I_{DSS} and V_{DS(on)} Specified at Elevated Temperatures

Applications

- Power Management in Portable and Battery-Powered Products, i.e.: Computers, Printers, PCMCIA Cards, Cellular and Cordless Telephones
- Battery Applications
- NoteBook PC

MAXIMUM RATINGS (T_C = 25°C unless otherwise noted)

Rating	Symbol	Value	Unit
Drain-to-Source Voltage	V _{DS}	20	Vdc
Drain-to-Gate Voltage (R _{GS} = 1.0 MΩ)	V _{DGR}	20	Vdc
Gate-to-Source Voltage – Continuous	V _{GS}	±12	Vdc
Thermal Resistance – Single Die Junction-to-Ambient (Note 1)	R _{θJA}	62.5	°C/W
Total Power Dissipation @ T _A = 25°C	P _D	2.0	W
Continuous Drain Current @ T _A = 25°C	I _D	6.9	A _{dc}
Pulsed Drain Current (Note 4)	I _{DM}	24	A _{dc}
Thermal Resistance – Single Die Junction-to-Ambient (Note 2)	R _{θJA}	88	°C/W
Total Power Dissipation @ T _A = 25°C	P _D	1.42	W
Continuous Drain Current @ T _A = 25°C	I _D	5.8	A _{dc}
Continuous Drain Current @ T _A = 70°C	I _D	4.6	A _{dc}
Pulsed Drain Current (Note 4)	I _{DM}	20	A _{dc}
Thermal Resistance – Single Die Junction-to-Ambient (Note 3)	R _{θJA}	132	°C/W
Total Power Dissipation @ T _A = 25°C	P _D	0.94	W
Continuous Drain Current @ T _A = 25°C	I _D	4.7	A _{dc}
Continuous Drain Current @ T _A = 70°C	I _D	3.8	A _{dc}
Pulsed Drain Current (Note 4)	I _{DM}	14	A _{dc}

1. Mounted onto a 2" square FR-4 board (1" sq. 2 oz Cu 0.06" thick single sided), t < 10 seconds.
2. Mounted onto a 2" square FR-4 board (1" sq. 2 oz Cu 0.06" thick single sided), t = 10 seconds.
3. Minimum FR-4 or G-10 PCB, t = steady state.
4. Pulse Test: Pulse Width = 300 μs, Duty Cycle = 2%.



ON Semiconductor™

<http://onsemi.com>

**6.9 AMPERES
20 VOLTS
30 mΩ @ V_{GS} = 4.5 V**

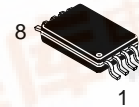
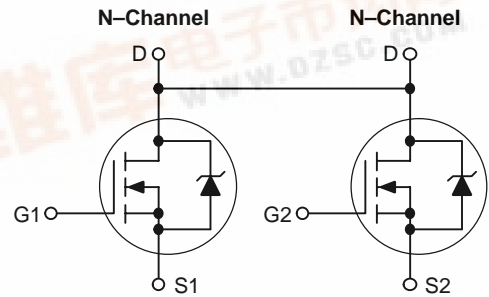

TSSOP-8
CASE 948S
PLASTIC

MARKING DIAGRAM & PIN ASSIGNMENT

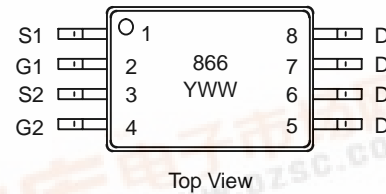

866 = Device Code
YWW = Date Code

ORDERING INFORMATION

Device	Package	Shipping
NTQD6866R2	TSSOP-8	4000/Tape & Reel

NTQD6866R2

MAXIMUM RATINGS (continued)

Rating	Symbol	Value	Unit
Thermal Resistance – Both Die Junction-to-Ambient (Note 5)	$R_{\theta JA}$	160	$^{\circ}\text{C}/\text{W}$
Total Power Dissipation @ $T_A = 25^{\circ}\text{C}$	P_D	0.78	W
Continuous Drain Current @ $T_A = 25^{\circ}\text{C}$	I_D	4.3	Adc
Pulsed Drain Current (Note 5)	I_{DM}	14	Adc
Operating and Storage Temperature Range	T_J, T_{stg}	-55 to +150	$^{\circ}\text{C}$
Single Pulse Drain-to-Source Avalanche Energy – Starting $T_J = 25^{\circ}\text{C}$ ($V_{DD} = 20\text{ Vdc}$, $V_{GS} = 5.0\text{ Vdc}$, Peak $I_L = 5.5\text{ Apk}$, $L = 10\text{ mH}$, $R_G = 25\ \Omega$)	E_{AS}	150	mJ
Maximum Lead Temperature for Soldering Purposes for 10 seconds	T_L	260	$^{\circ}\text{C}$

ELECTRICAL CHARACTERISTICS ($T_C = 25^{\circ}\text{C}$ unless otherwise noted)

Characteristic	Symbol	Min	Typ	Max	Unit
----------------	--------	-----	-----	-----	------

OFF CHARACTERISTICS

Drain-to-Source Breakdown Voltage ($V_{GS} = 0\text{ Vdc}$, $I_D = 250\ \mu\text{Adc}$)	$V_{(BR)DSS}$	20	–	–	Vdc
Temperature Coefficient (Positive)		–	18.5	–	$\text{mV}/^{\circ}\text{C}$
Zero Gate Voltage Drain Current ($V_{GS} = 0\text{ Vdc}$, $V_{DS} = 20\text{ Vdc}$, $T_J = 25^{\circ}\text{C}$)	I_{DSS}	–	–	1.0	μAdc
($V_{GS} = 0\text{ Vdc}$, $V_{DS} = 20\text{ Vdc}$, $T_J = 100^{\circ}\text{C}$)		–	–	10	
Gate-Body Leakage Current ($V_{GS} = \pm 12\text{ Vdc}$, $V_{DS} = 0\text{ Vdc}$)	I_{GSS}	–	–	± 100	nAdc

ON CHARACTERISTICS

Gate Threshold Voltage ($V_{DS} = V_{GS}$, $I_D = 250\ \mu\text{Adc}$)	$V_{GS(th)}$	0.6	0.9	1.2	Vdc
Temperature Coefficient (Negative)		–	-2.7	–	$\text{mV}/^{\circ}\text{C}$
Static Drain-to-Source On-State Resistance ($V_{GS} = 4.5\text{ Vdc}$, $I_D = 6.9\text{ Adc}$)	$R_{DS(on)}$	–	0.026	0.032	Ω
($V_{GS} = 4.5\text{ Vdc}$, $I_D = 5.8\text{ Adc}$)		–	0.025	0.030	
($V_{GS} = 2.5\text{ Vdc}$, $I_D = 3.5\text{ Adc}$)		–	0.030	0.038	
($V_{GS} = 2.5\text{ Vdc}$, $I_D = 2.9\text{ Adc}$)		–	0.030	0.038	
Forward Transconductance ($V_{DS} = 10\text{ Vdc}$, $I_D = 5.8\text{ Adc}$)	g_{FS}	–	14	–	Mhos

DYNAMIC CHARACTERISTICS

Input Capacitance	$(V_{DS} = 16\text{ Vdc}$, $V_{GS} = 0\text{ Vdc}$, $f = 1.0\text{ MHz})$	C_{iss}	–	875	1400	μF
Output Capacitance		C_{oss}	–	325	550	
Reverse Transfer Capacitance		C_{rss}	–	100	175	

5. Pulse Test: Pulse Width = 300 μs , Duty Cycle = 2%.

NTQD6866R2

ELECTRICAL CHARACTERISTICS (continued)

Characteristic	Symbol	Min	Typ	Max	Unit
----------------	--------	-----	-----	-----	------

SWITCHING CHARACTERISTICS (Notes 6 & 7)

Turn-On Delay Time	($V_{DD} = 16 \text{ Vdc}$, $I_D = 5.8 \text{ Adc}$, $V_{GS} = 4.5 \text{ Vdc}$, $R_G = 6.0 \Omega$)	$t_{d(on)}$	–	10	18	ns
Rise Time		t_r	–	45	80	
Turn-Off Delay Time		$t_{d(off)}$	–	40	75	
Fall Time		t_f	–	90	150	
Turn-On Delay Time	($V_{DD} = 16 \text{ Vdc}$, $I_D = 5.8 \text{ Adc}$, $V_{GS} = 4.5 \text{ Vdc}$, $R_G = 3.0 \Omega$)	$t_{d(on)}$	–	8.0	–	ns
Rise Time		t_r	–	45	–	
Turn-Off Delay Time		$t_{d(off)}$	–	35	–	
Fall Time		t_f	–	75	–	
Gate Charge	($V_{DS} = 16 \text{ Vdc}$, $V_{GS} = 4.5 \text{ Vdc}$, $I_D = 5.8 \text{ Adc}$)	Q_{tot}	–	13	22	nC
		Q_{gs}	–	1.8	–	
		Q_{gd}	–	4.5	–	

BODY-DRAIN DIODE RATINGS (Note 6)

Forward On-Voltage	($I_S = 5.8 \text{ Adc}$, $V_{GS} = 0 \text{ Vdc}$) ($I_S = 5.8 \text{ Adc}$, $V_{GS} = 0 \text{ Vdc}$, $T_J = 100^\circ\text{C}$)	V_{SD}	–	0.85 0.75	1.0 –	Vdc
Reverse Recovery Time	($I_S = 5.8 \text{ Adc}$, $V_{GS} = 0 \text{ Vdc}$, $V_{DS} = 20 \text{ Vdc}$, $dI_S/dt = 100 \text{ A}/\mu\text{s}$)	t_{rr}	–	23	–	ns
		t_a	–	12	–	
		t_b	–	11	–	
Reverse Recovery Stored Charge		Q_{RR}	–	0.013	–	μC

6. Pulse Test: Pulse Width = 300 μs , Duty Cycle = 2%.

7. Switching characteristics are independent of operating junction temperature.

NTQD6866R2

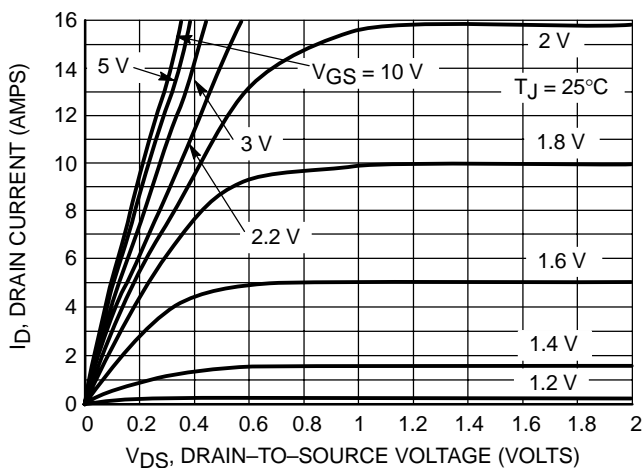

Figure 1. On-Region Characteristics

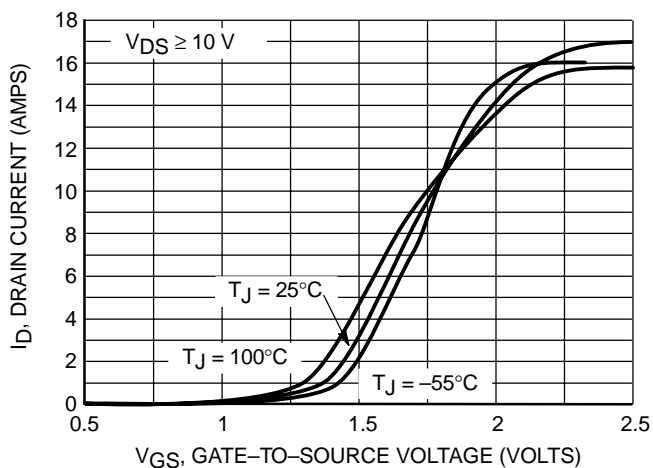

Figure 2. Transfer Characteristics

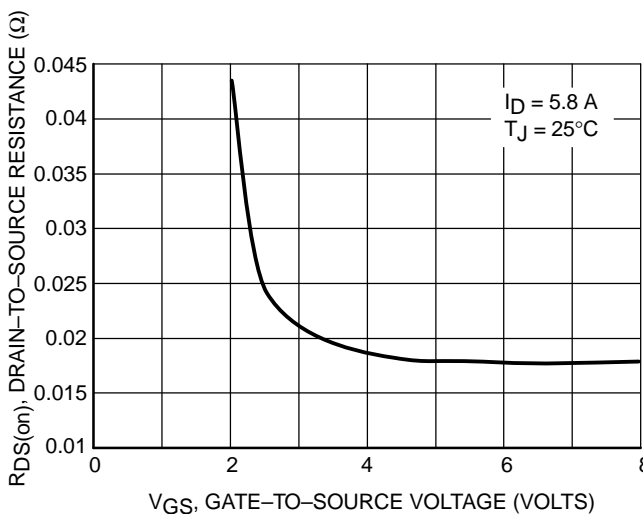

Figure 3. On-Resistance versus Gate-to-Source Voltage

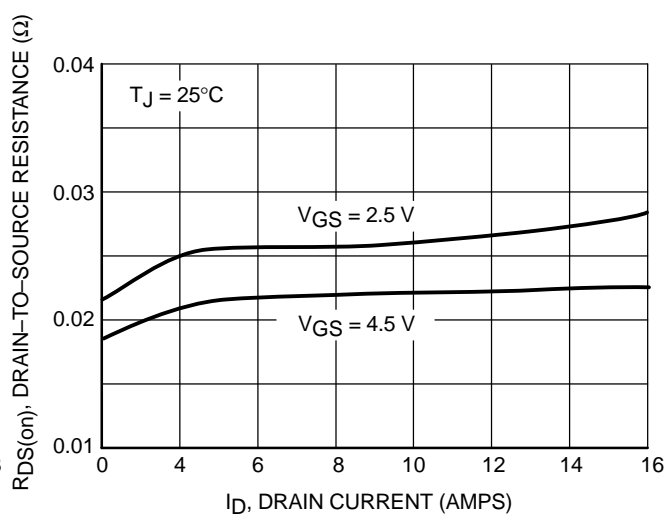

Figure 4. On-Resistance versus Drain Current and Gate Voltage

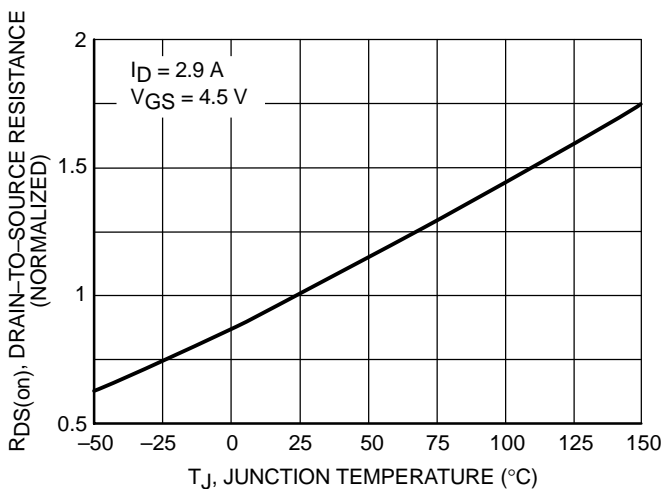

Figure 5. On-Resistance Variation with Temperature

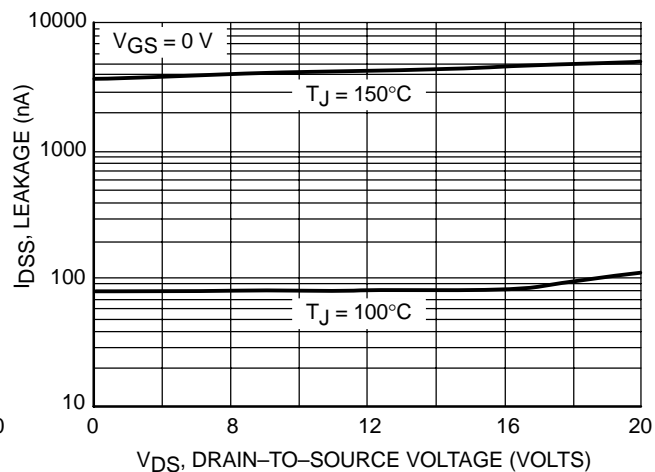

Figure 6. Drain-to-Source Leakage Current versus Voltage

NTQD6866R2

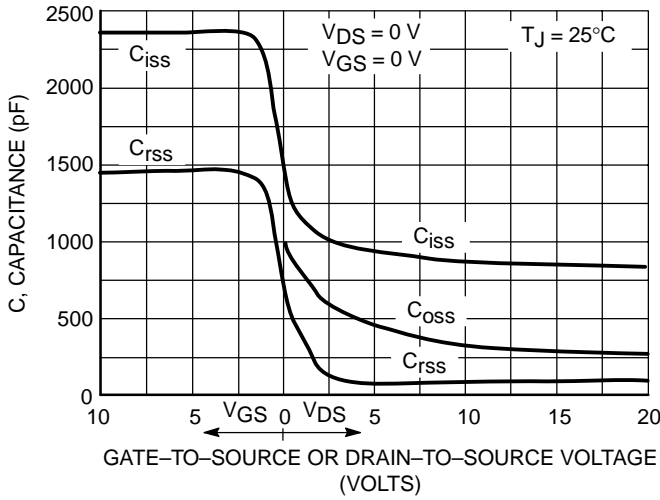

Figure 7. Capacitance Variation

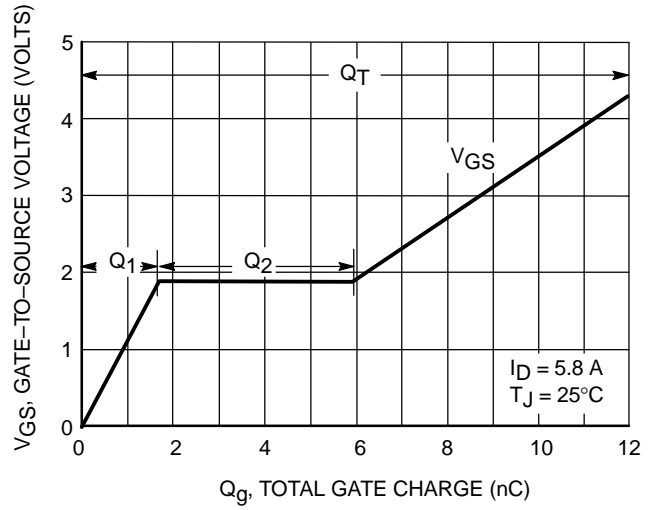

Figure 8. Gate-to-Source Voltage versus Total Charge

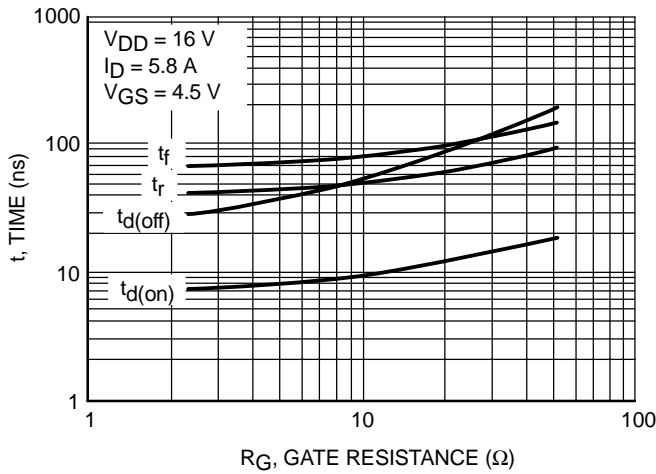

Figure 9. Resistive Switching Time Variation versus Gate Resistance

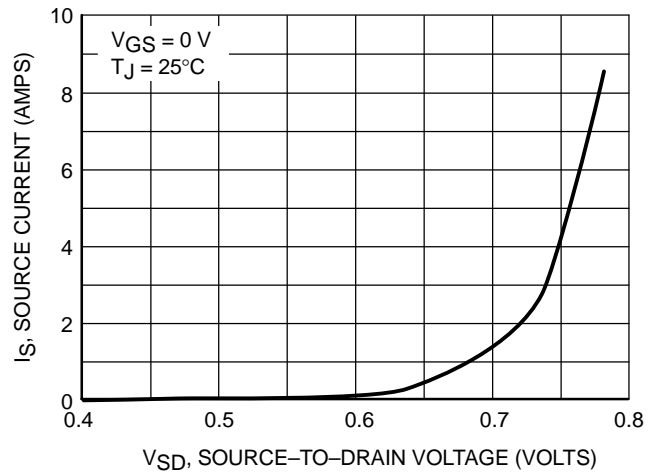

Figure 10. Diode Forward Voltage versus Current

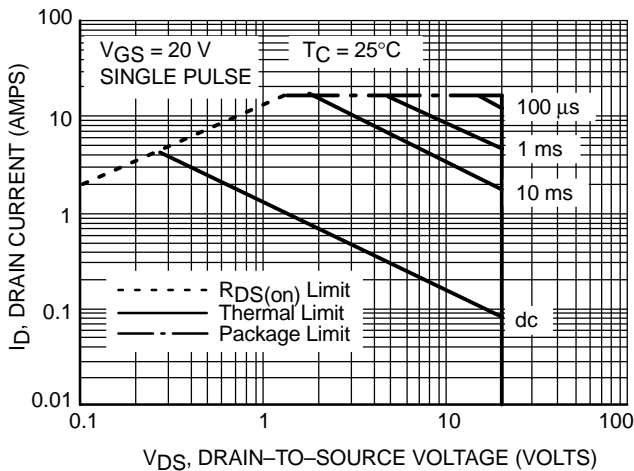

Figure 11. Maximum Rated Forward Biased Safe Operating Area

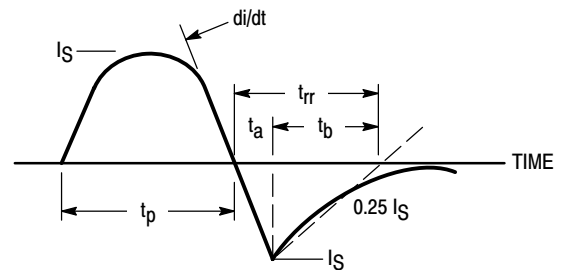

Figure 12. Diode Reverse Recovery Waveform

NTQD6866R2

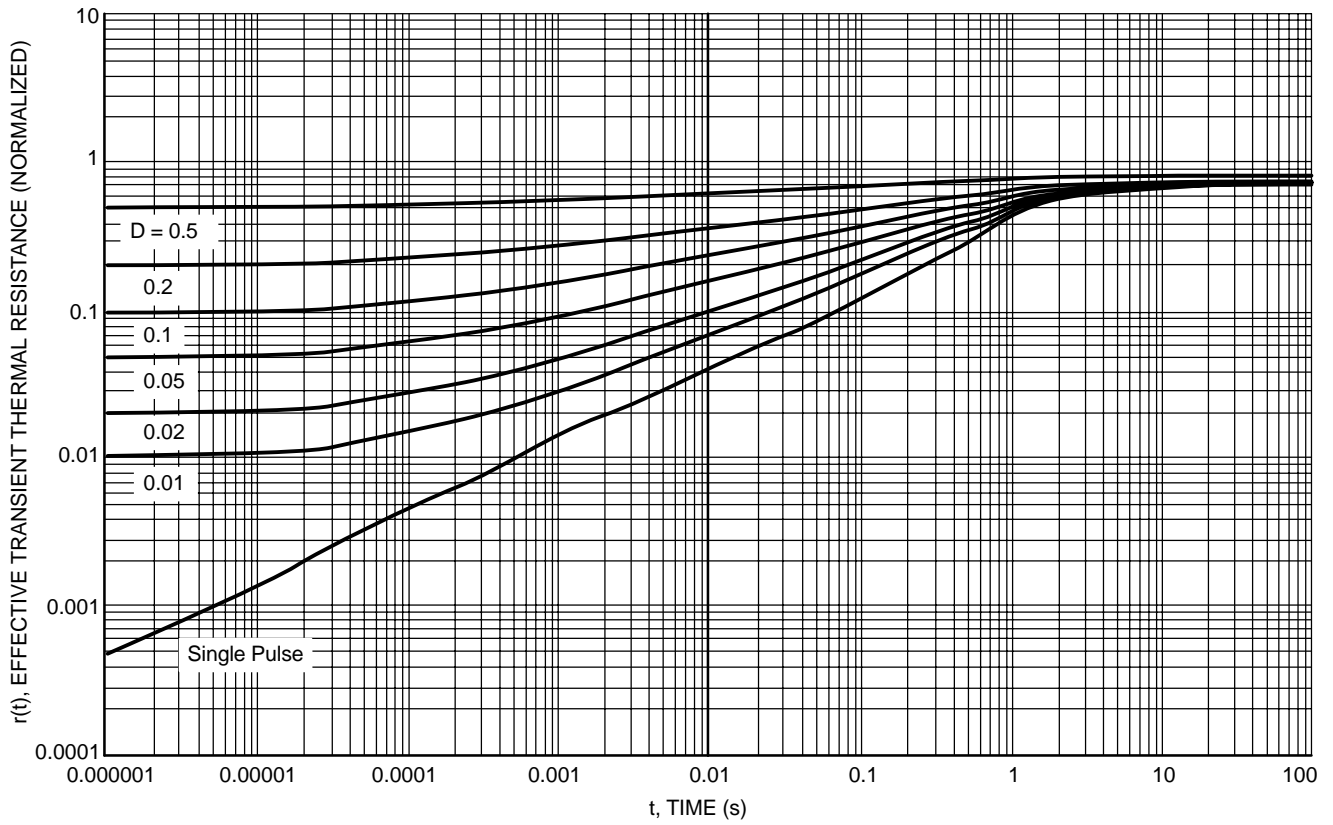

Figure 13. Thermal Response

NTQD6866R2

INFORMATION FOR USING THE TSSOP-8 SURFACE MOUNT PACKAGE

RECOMMENDED FOOTPRINT FOR SURFACE MOUNTED APPLICATIONS

Surface mount board layout is a critical portion of the total design. The footprint for the semiconductor packages must be the correct size to ensure proper solder connection

interface between the board and the package. With the correct pad geometry, the packages will self align when subjected to a solder reflow process.

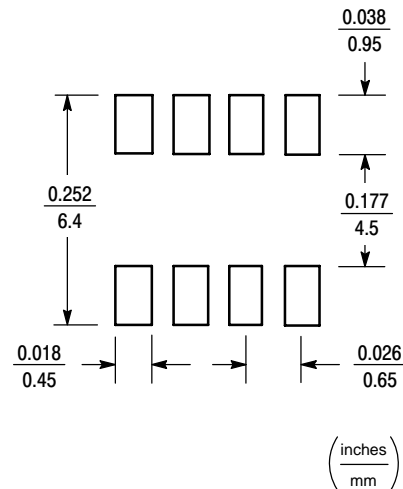

SOLDERING PRECAUTIONS

The melting temperature of solder is higher than the rated temperature of the device. When the entire device is heated to a high temperature, failure to complete soldering within a short time could result in device failure. Therefore, the following items should always be observed in order to minimize the thermal stress to which the devices are subjected.

- Always preheat the device.
- The delta temperature between the preheat and soldering should be 100°C or less.*
- When preheating and soldering, the temperature of the leads and the case must not exceed the maximum temperature ratings as shown on the data sheet. When using infrared heating with the reflow soldering method, the difference shall be a maximum of 10°C.
- The soldering temperature and time shall not exceed 260°C for more than 10 seconds.

- When shifting from preheating to soldering, the maximum temperature gradient shall be 5°C or less.
- After soldering has been completed, the device should be allowed to cool naturally for at least three minutes. Gradual cooling should be used as the use of forced cooling will increase the temperature gradient and result in latent failure due to mechanical stress.
- Mechanical stress or shock should not be applied during cooling.

* * Soldering a device without preheating can cause excessive thermal shock and stress which can result in damage to the device.

* * Due to shadowing and the inability to set the wave height to incorporate other surface mount components, the D²PAK is not recommended for wave soldering.

NTQD6866R2

TYPICAL SOLDER HEATING PROFILE

For any given circuit board, there will be a group of control settings that will give the desired heat pattern. The operator must set temperatures for several heating zones, and a figure for belt speed. Taken together, these control settings make up a heating "profile" for that particular circuit board. On machines controlled by a computer, the computer remembers these profiles from one operating session to the next. Figure 14 shows a typical heating profile for use when soldering a surface mount device to a printed circuit board. This profile will vary among soldering systems but it is a good starting point. Factors that can affect the profile include the type of soldering system in use, density and types of components on the board, type of solder used, and the type of board or substrate material being used. This profile shows temperature versus time. The line on the graph shows the

actual temperature that might be experienced on the surface of a test board at or near a central solder joint. The two profiles are based on a high density and a low density board. The Vitronics SMD310 convection/infrared reflow soldering system was used to generate this profile. The type of solder used was 62/36/2 Tin Lead Silver with a melting point between 177–189°C. When this type of furnace is used for solder reflow work, the circuit boards and solder joints tend to heat first. The components on the board are then heated by conduction. The circuit board, because it has a large surface area, absorbs the thermal energy more efficiently, then distributes this energy to the components. Because of this effect, the main body of a component may be up to 30 degrees cooler than the adjacent solder joint.

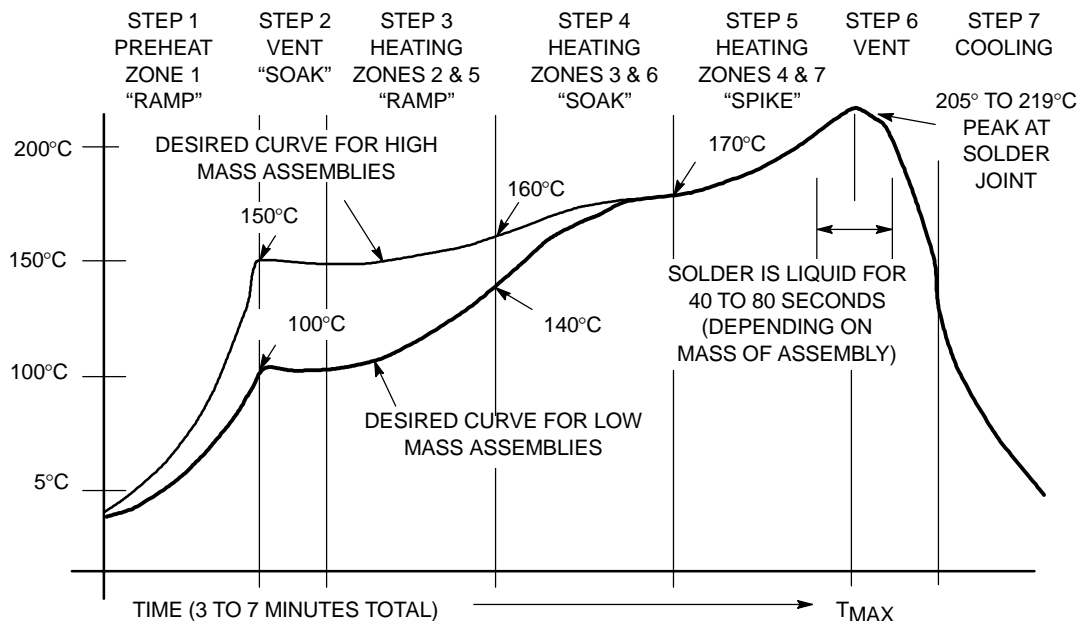
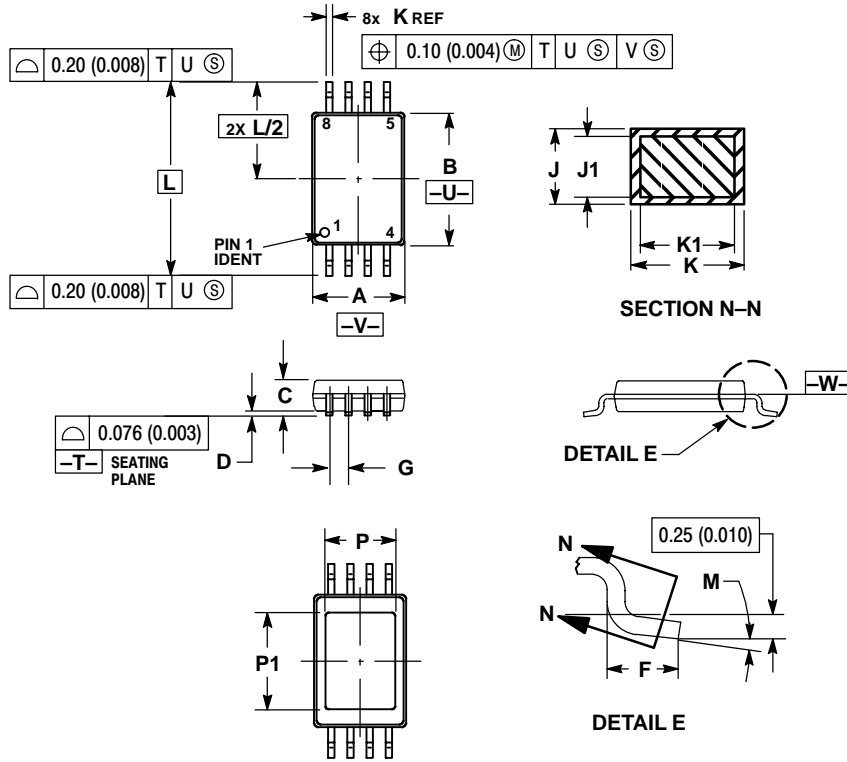

Figure 14. Typical Solder Heating Profile

NTQD6866R2

PACKAGE DIMENSIONS

TSSOP-8
CASE 948S-01
PLASTIC
ISSUE O



NOTES:

1. DIMENSIONING AND TOLERANCING PER ANSI Y14.5M, 1982.
2. CONTROLLING DIMENSION: MILLIMETER.
3. DIMENSION A DOES NOT INCLUDE MOLD FLASH, PROTRUSIONS OR GATE BURRS. MOLD FLASH OR GATE BURRS SHALL NOT EXCEED 0.15 (0.006) PER SIDE.
4. DIMENSION B DOES NOT INCLUDE INTERLEAD FLASH OR PROTRUSION. INTERLEAD FLASH OR PROTRUSION SHALL NOT EXCEED 0.25 (0.010) PER SIDE.
5. TERMINAL NUMBERS ARE SHOWN FOR REFERENCE ONLY.
6. DIMENSION A AND B ARE TO BE DETERMINED AT DATUM PLANE -W-.

DIM	MILLIMETERS		INCHES	
	MIN	MAX	MIN	MAX
A	2.90	3.10	0.114	0.122
B	4.30	4.50	0.169	0.177
C	---	1.10	---	0.043
D	0.05	0.15	0.002	0.006
F	0.50	0.70	0.020	0.028
G	0.65 BSC		0.026 BSC	
J	0.09	0.20	0.004	0.008
J1	0.09	0.16	0.004	0.006
K	0.19	0.30	0.007	0.012
K1	0.19	0.25	0.007	0.010
L	6.40 BSC		0.252 BSC	
M	0°	8°	0°	8°
P	---	2.20	---	0.087
P1	---	3.20	---	0.126

NTQD6866R2

Notes

NTQD6866R2

Notes

NTQD6866R2

ON Semiconductor and  are trademarks of Semiconductor Components Industries, LLC (SCILLC). SCILLC reserves the right to make changes without further notice to any products herein. SCILLC makes no warranty, representation or guarantee regarding the suitability of its products for any particular purpose, nor does SCILLC assume any liability arising out of the application or use of any product or circuit, and specifically disclaims any and all liability, including without limitation special, consequential or incidental damages. "Typical" parameters which may be provided in SCILLC data sheets and/or specifications can and do vary in different applications and actual performance may vary over time. All operating parameters, including "Typicals" must be validated for each customer application by customer's technical experts. SCILLC does not convey any license under its patent rights nor the rights of others. SCILLC products are not designed, intended, or authorized for use as components in systems intended for surgical implant into the body, or other applications intended to support or sustain life, or for any other application in which the failure of the SCILLC product could create a situation where personal injury or death may occur. Should Buyer purchase or use SCILLC products for any such unintended or unauthorized application, Buyer shall indemnify and hold SCILLC and its officers, employees, subsidiaries, affiliates, and distributors harmless against all claims, costs, damages, and expenses, and reasonable attorney fees arising out of, directly or indirectly, any claim of personal injury or death associated with such unintended or unauthorized use, even if such claim alleges that SCILLC was negligent regarding the design or manufacture of the part. SCILLC is an Equal Opportunity/Affirmative Action Employer.

PUBLICATION ORDERING INFORMATION

Literature Fulfillment:

Literature Distribution Center for ON Semiconductor
P.O. Box 5163, Denver, Colorado 80217 USA
Phone: 303-675-2175 or 800-344-3860 Toll Free USA/Canada
Fax: 303-675-2176 or 800-344-3867 Toll Free USA/Canada
Email: ONlit@hibbertco.com

N. American Technical Support: 800-282-9855 Toll Free USA/Canada

JAPAN: ON Semiconductor, Japan Customer Focus Center
4-32-1 Nishi-Gotanda, Shinagawa-ku, Tokyo, Japan 141-0031
Phone: 81-3-5740-2700
Email: r14525@onsemi.com

ON Semiconductor Website: <http://onsemi.com>

For additional information, please contact your local Sales Representative.