



- **SAW Frequency Stabilization**
- **Fundamental-Mode Oscillation at 1090.0 MHz**
- **Ideal for IFF Transponder Applications**

The frequency of this oscillator is stabilized by surface-acoustic-wave (SAW) technology. This results in excellent performance from a compact, rugged, hermetically-sealed oscillator operating at the fundamental frequency of 1090.0 MHz. The highly-reliable HO1081 is designed for use in identify-friend-or-foe (IFF) radar transponders in military aviation. Military Screening is available as an option. The HO1081 is a high-performance version of the HO1079 oscillator.

HO1081

**1090.0 MHz
SAW
Oscillator**

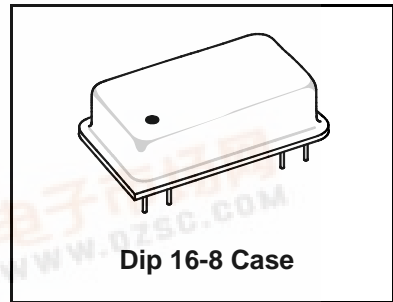

Absolute Maximum Ratings

Rating		Value	Units
DC Supply Voltage		0 to +13	VDC
Ambient Temperature	Powered	-55 to +105	°C
	Storage	-55 to -125	

Electrical Characteristics

Characteristic		Sym	Notes	Minimum	Typical	Maximum	Units
Operating Frequency	Absolute Frequency	f_o	1, 7	1089.750	1090.0	1090.250	MHz
	Tolerance from 1090.0 MHz	Δf_o				± 250	kHz
RF Output Power		P_o	3, 6	+10	+12	+14	dBm
Discrete Spurious	Second Harmonics		2, 3, 4		-25	-20	dBc
	Third and Higher Harmonics				-35	-30	
	Nonharmonic				<-100	-80	
SSB Phase Noise	1 kHz Offset		2, 3, 4		-100	-90	dBc/Hz
	10 kHz Offset				-120	-110	
RF Impedance	Nominal Impedance	Z_o	3		50		Ω
	Operating Load VSWR	G_L	3, 5			1.5:1	
DC Power Supply	Operating Voltage	V_{CC}	3, 6	11.75	12.0	12.25	VDC
	Operating Current	I_{CC}				35	40
Operating Ambient Temperature		T_A	3, 6	-55		+105	°C
Lid Symbolization (YY=Year, WW=Week)				RFM HO1081 YYWW			



CAUTION: Electrostatic Sensitive Device. Observe precautions for handling. COCOM CAUTION: Approval by the U.S. Department of Commerce is required prior to export of this device.

Notes:

1. One or more of the following United States patents apply: 4,616,197; 4,610,681; and 4,761,616.
2. Unless noted otherwise, all specifications are listed at $T_A = +25^\circ\text{C} \pm 2^\circ\text{C}$, $V_{CC} =$ nominal voltage ± 0.01 VDC, and load impedance = 50Ω with $VSWR \leq 1.5:1$.
3. The design, manufacturing process, and specifications of this device are subject to change without notice.
4. Applies to oscillator only and not to sidebands caused by external electrical or mechanical sources. (Dedicated external voltage regulation with low-frequency filtering for the DC power supply and proper circuit board layout are recommended for optimum spectral purity.)
5. For specified maximum operating load VSWR (any angle) at F_o . (No instability or damage will occur for any passive load impedance.)
Applies for any combination of V_{CC} and T_A within the specified operating ranges.
Applies for any combination of Note 5 and 6 conditions.

BLOCK DIAGRAM

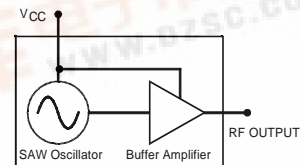

ELECTRICAL CONNECTIONS

